

ATI2305 DC-DC Converter

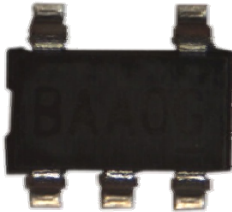

Figure 1. Physical Photo of ATI2305 DC-DC Converter

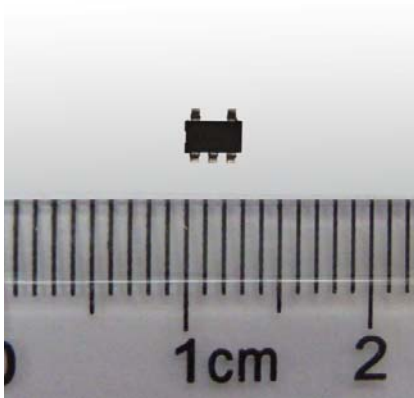

Figure 2. Physical Photo of ATI2305 DC-DC Converter

FEATURES

- Efficiency up to 96%
- Only 40 μ A (TYP.) Quiescent Current
- Output Current up to 1A
- Internal Synchronous Rectifier
- Switching Frequency: 1.5MHz
- Under-Voltage Lockout
- Soft Start
- Short Circuit Protection
- Thermal Shutdown
- 5-pin Small SOT23-5, DFN2X2 6-Pin and QFN3X3 16-Pin Package
- Pb-Free Package

APPLICATIONS

It is widely used in cellular phone, portable electronics, wireless devices, cordless phone, computer peripherals, battery powered widgets, electronic scales, digital frame, etc.

DESCRIPTION

The ATI2305 is a 1.5MHz switching frequency step-down current-mode, DC-DC converter. With excellent stability and transient response, the constant-frequency PWM control works well at heavy load. There is a power-saving Pulse-Skipping Modulation (PSM) mode in the ATI2305 which can reduce quiescent current under light load operation to save power and ensure the longest battery life in portable applications.

The ATI2305 allows input voltages from 2.5V to 5.5V, allowing the use of a single Li+/Li-polymer cell, multiple Alkaline/NiMH cell, USB, and other standard power sources. The output voltage can be adjustable from 0.6V to the input voltage. The part number suffix ATI2305-XX indicates preset output voltage of 3.3V, 2.8V, 2.5V, 1.8V, 1.5V, 1.2V or adjustable. Internal power switch and synchronous rectifier are used by all versions to minimize external part count and realize high efficiency. During shutdown, the input is disconnected from the output and the shutdown current is less than 0.1 μ A. Other key features include under-voltage lockout to prevent deep battery discharge.

Three packages are available for ATI2305: SOT23-5, DFN2X2 6-Pin and QFN3X3 16-Pin.

TYPICAL APPLICATION

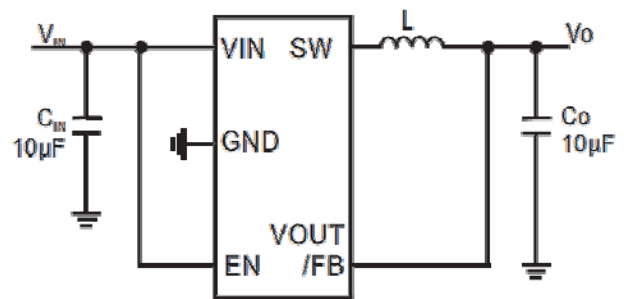

Figure 3. Fixed Output Voltage

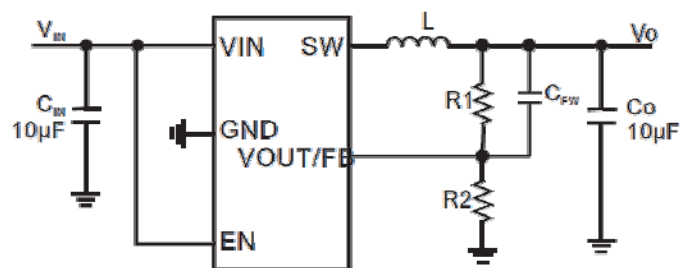

Figure 4. Adjustable Output Voltage

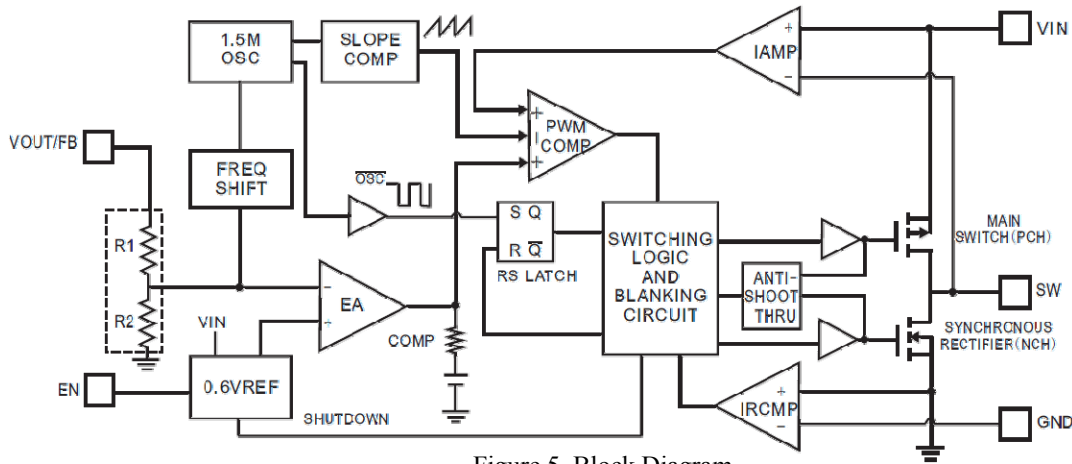
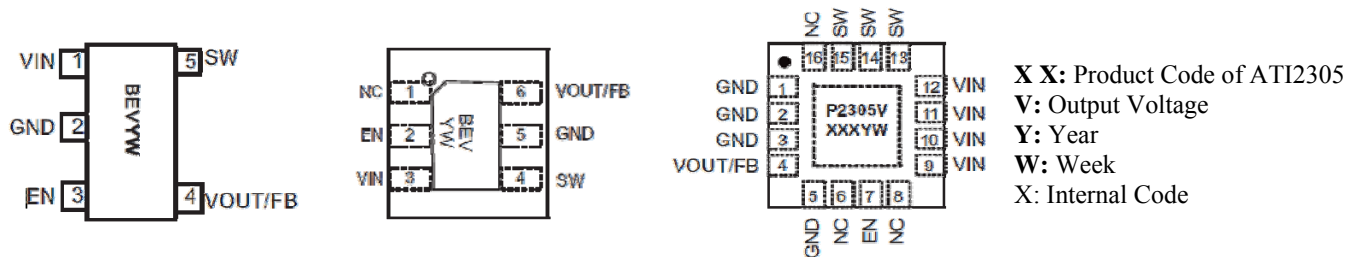

Figure 5. Block Diagram

Pin Configuration & Marking Information



X X: Product Code of ATI2305
V: Output Voltage
Y: Year
W: Week
X: Internal Code

Figure 6. Top View of SOT-23-5 Figure 7. Top View of DFN2x2 6L Figure 8. Top View of QFN 3x3 16L

Pin Description

Table 1.

Name	Function
EN	Enable control input. Force this pin voltage above 1.5V, enables the chip, and below 0.3V shuts down the device.
GND	Ground
SW	The drains of the internal main and synchronous power MOSFET.
VIN	Chip main power supply pin
VOUT/FB	VOUT: Output voltage feedback pin, an internal resistive divider divides the output voltage down for comparison to the internal reference voltage. FB: Feedback voltage to internal error amplifier, the threshold voltage is 0.6V.
NC	No connection

Absolute Maximum Ratings

These are stress ratings only and functional operation is not implied. Exposure to absolute maximum ratings for prolonged time periods may affect device reliability. All voltages are with respect to ground.

Input Voltage.....	-0.3V to 6.0V	Junction Temperature.....	150°C
EN, FB Pin Voltage.....	-0.3V to V _{IN}	Storage Temperature Range.....	-65°C to 150°C
SW Pin Voltage.....	-0.3V to (V _{IN} +0.3V)	Soldering Temperature.....	300°C, 5 sec

Recommended Operating Conditions

Supply Voltage.....	2.5V to 5.5V	Operation Temperature Range.....	-40°C to 85 °C
Junction Temperature Range.....	-40°C to 125°C		



Thermal Information

Table 2.

Parameter	Package	Symbol	Maximum	Unit
Thermal Resistance (Junction to Case)	SOT23-5 ^{Note}	θ_{JC}	130	°C/W
	DFN 2×2-6		25	
	QFN 3×3-16		14	
Thermal Resistance (Junction to Ambient)	SOT23-5	θ_{JA}	250	
	DFN 2×2-6		68	
	QFN 3×3-16		35	
Internal Power Dissipation	SOT23-5	P_D	400	mW
	DFN 2×2-6		980	
	QFN 3×3-16		1470	

NOTE:

The maximum output current for SOT23-5 package is limited by internal power dissipation capacity as described in Application Information hereinafter.

CHARACTERISTICS

$T_A = 25^\circ\text{C}$, $V_{IN} = 3.6\text{V}$, $V_O = 1.8\text{V}$, $C_{IN} = 10\mu\text{F}$, $L = 4.7\mu\text{H}$, unless otherwise noted.

Table 3.

PARAMETER	SYMBOL	Test Conditions	MIN	TYP	MAX	UNITS
Input Voltage Range	V_{IN}		2.5		5.5	V
Regulated Feedback Voltage	V_{FB}		0.588	0.6	0.612	V
Reference Voltage Line Regulation	ΔV_{FB}			0.3		%/V
Regulated Output Voltage Accuracy	V_O	$I_O = 100\text{mA}$	-3		+3	%
Peak Inductor Current	I_{PK}	$V_{IN} = 3\text{V}$, $V_{FB} = 0.5\text{V}$ or $V_O = 90\%$		1.5		A
Output Voltage Line Regulation	LNR	$V_{IN} = 2.5\text{V}$ to 5V , $I_O = 10\text{mA}$		0.2	0.5	%/V
Output Voltage Load Regulation	LDR	$I_O = 1\text{mA}$ to 800mA		0.5	1.5	%
Quiescent Current	I_Q	No load		40	70	uA
Shutdown Current	I_{SD}	$V_{EN} = 0\text{V}$		0.1	1	uA
Oscillator Frequency	F_{OSC}	$V_O = 100\%$	1.2	1.5	1.8	MHz
		$V_{FB} = 0\text{V}$ or $V_O = 0\text{V}$		500		KHz
Drain-Source On-State Resistance	$R_{DS(ON)}$	$I_{DS} = 100\text{mA}$	P MOSFET	0.3	0.45	Ω
			N MOSFET	0.35	0.5	Ω
SW Leakage Current	I_{LSW}			±0.01	1	uA
EN Threshold High	V_{EH}		1.5			V
EN Threshold Low	V_{EL}				0.3	V
EN Leakage Current	I_{EN}			±0.01		uA
High Efficiency	η			96		%
Over Temperature Protection	OTP			150		°C
OTP Hysteresis	OTH			30		°C



APPLICATION INFORMATION

Inductor Selection

For most application, the inductor value is from 1μH to 4.7μH. Its value is chosen based on the desired ripple current. Large value inductors lower ripple current and small value inductors result in higher ripple current. Higher V_{IN} or V_{OUT} also increases the ripple current as shown in the following equation. A reasonable starting point for setting ripple current is $\Delta I_L = 400\text{mA}$ (40% of 1A).

$$\Delta I_L = \frac{1}{(f)(L)} V_{OUT} \left(1 - \frac{V_{OUT}}{V_{IN}} \right)$$

The DC current rating of the inductor should be at least equal to the maximum load current plus half the ripple current to prevent core saturation. Thus, a 1.4A rated inductor should be enough for most applications (1A + 400mA). For better efficiency, choose a low DC-resistance inductor.

V_O	1.2V	1.5V	1.8V	2.5V	3.3V
L	2.2μH	2.2μH	2.2μH	4.7μH	4.7μH

C_{IN} and C_{OUT} Selection

In continuous mode, the source current of the top MOSFET is a square wave of duty cycle V_{OUT}/V_{IN} . To prevent large voltage transients, a low ESR input capacitor sized for the maximum RMS current must be used. The maximum RMS capacitor current is given by:

$$C_{IN} \text{ required } I_{RMS} \cong I_{OMAX} \frac{[V_{OUT}(V_{IN} - V_{OUT})]^{1/2}}{V_{IN}}$$

This formula has a maximum at $V_{IN} = 2V_{OUT}$, where $I_{RMS} = I_{OUT}/2$. This simple worst-case condition is commonly used for design because even significant deviations do not offer much relief. Note that the capacitor manufacturer's ripple current ratings are often based on 2000 hours of life. This makes it advisable to further derate the capacitor, or choose a capacitor rated at a higher temperature than required. Consult the manufacturer if there is any question.

The selection of C_{OUT} is on the basis of required effective series resistance (ESR).

Typically, once the ESR requirement for C_{OUT} has been met, the RMS current rating generally far exceeds the $I_{RIPPLE}(P-P)$ requirement. The output ripple ΔV_{OUT} is determined by:

$$\Delta V_{OUT} \cong V_{IL} \left(ESR + \frac{1}{8fC_{OUT}} \right)$$

Where f = operating frequency, C_{OUT} = output capacitance and ΔI_L = ripple current in the inductor. For a fixed output voltage, the output ripple is highest at maximum input

voltage since ΔI_L increases with input voltage.

Using Ceramic Input and Output Capacitors

Higher values, lower cost ceramic capacitors are now becoming available in smaller case sizes. Their high ripple current, high voltage rating and low ESR make them ideal for switching regulator applications. Using ceramic capacitors can achieve very low output ripple and small circuit size.

When choosing the input and output ceramic capacitors, choose the X5R or X7R dielectric formulations. These dielectrics have the best temperature and voltage characteristics of all the ceramics for a given value and size.

Thermal Consideration

Thermal protection limits power dissipation in the ATI2305. When the junction temperature exceeds 150°C, the OPT (Over Temperature Protection) starts the thermal shutdown and turns the pass transistor off. The pass transistor resumes operation after the junction temperature drops below 120°C.

For continuous operation, the junction temperature should be maintained below 125°C. The power dissipation is defined as:

$$P_D = I_O^2 \frac{V_O R_{DS(ON)} + (V_{IN} - V_O) R_{DS(ON)} + (T_{sw} F_S I_O + I_Q) V_{IN}}{V_{IN}}$$

I_Q is the step-down converter quiescent current. The term t_{sw} is used to estimate the full load step-down converter switching losses.

For the condition where the step-down converter is in dropout at 100% duty cycle, the total device dissipation reduces to:

$$P_D = I_O^2 R_{DS(ON)} + I_Q V_{IN}$$

Since $R_{DS(ON)}$, quiescent current and switching losses all vary with input voltage, the total losses should be investigated over the complete input voltage range. The maximum power dissipation depends on the thermal resistance of IC package, PCB layout, the rate of surrounding airflow and temperature difference between junction and ambient. The maximum power dissipation can be calculated by the following formula:

$$P_D = \frac{T_{J(MAX)} - T_A}{\theta_{JA}}$$

Where $T_{J(MAX)}$ is the maximum allowable junction temperature 125°C. T_A is the ambient temperature and θ_{JA} is the thermal resistance from the junction to the ambient. Based on the standard JEDEC for a two layers thermal test board, the thermal resistance θ_{JA} of SOT23-5 package is 250°C/W, DFN2×2 102°C/W, and QFN3×3 68°C/W, respectively. The maximum power dissipation at $T_A = 25^\circ\text{C}$ can be calculated by following formula:

SOT-25 package:

$$P_D = (125^\circ\text{C} - 25^\circ\text{C}) / 250^\circ\text{C}/\text{W} = 0.4\text{W}$$

DFN2x2 package:

$$P_D = (125^\circ\text{C} - 25^\circ\text{C}) / 102^\circ\text{C}/\text{W} = 0.984\text{W}$$

QFN3x3 package:

$$P_D = (125^\circ\text{C} - 25^\circ\text{C}) / 68^\circ\text{C}/\text{W} = 1.47\text{W}$$

Setting the Output Voltage

The internal reference is 0.6V (Typical). The output voltage is calculated as below:

$$V_O = 0.6 \times \left(1 + \frac{R1}{R2} \right)$$

The output voltage is given by Table 4.

Table 4. Resistor selection for output voltage setting

V _O	R1	R2
1.2V	100K	100K
1.5V	150K	100K
1.8V	200K	100K
2.5V	380K	120K
3.3V	540K	120K

100% Duty Cycle Operation

As the input voltage approaches the output voltage, the converter turns the P-channel transistor continuously on. In this mode the output voltage is equal to the input voltage minus the voltage drop across the P-channel transistor:

$$V_{OUT} = V_{IN} - I_{LOAD} (R_{DSON} + R_L)$$

Where R_{DSON} = P-channel switch on resistance, I_{LOAD} = output current, R_L = inductor DC resistance.

UVLO and Soft-Start

The reference and the circuit remain reset until the V_{IN} crosses its UVLO threshold.

The ATI2305 comes with an internal soft-start circuit that limits the in-rush current during start-up. This prevents possible voltage drops of the input voltage and eliminates the output voltage overshoot. The soft-start is used as a digital circuit to increase the switch current in several steps to the P-channel current limit (1500mA).

Short Circuit Protection

The switch peak current is limited cycle-by-cycle to a typical value of 1500mA. When an output voltage short circuit, the device works with a frequency of 400 kHz and

minimum duty cycle, therefore the average input current is typically 200mA.

Thermal Shutdown

When the die temperature exceeds 150°C, a reset occurs and the reset remains until the temperature decreases to 120°C, at which time the circuit can be restarted.

PCB Layout Check List

When laying out the printed circuit board, the following checklist should be used to ensure proper operation of the ATI2305. These items are also illustrated graphically in Figure 9. Check the following in your layout:

1. The power traces, consisting of the GND trace, the SW trace and the VIN trace should be kept short, direct and wide.
2. The resistive divider R1/R2 must be connected between the (+) plate of C_{OUT} and ground.
3. This capacitor provides the AC current to the internal power MOSFETs.
4. Keep the switching node, SW, away from the sensitive VFB node.
5. Keep the (-) plates of C_{IN} and C_{OUT} as close as possible.

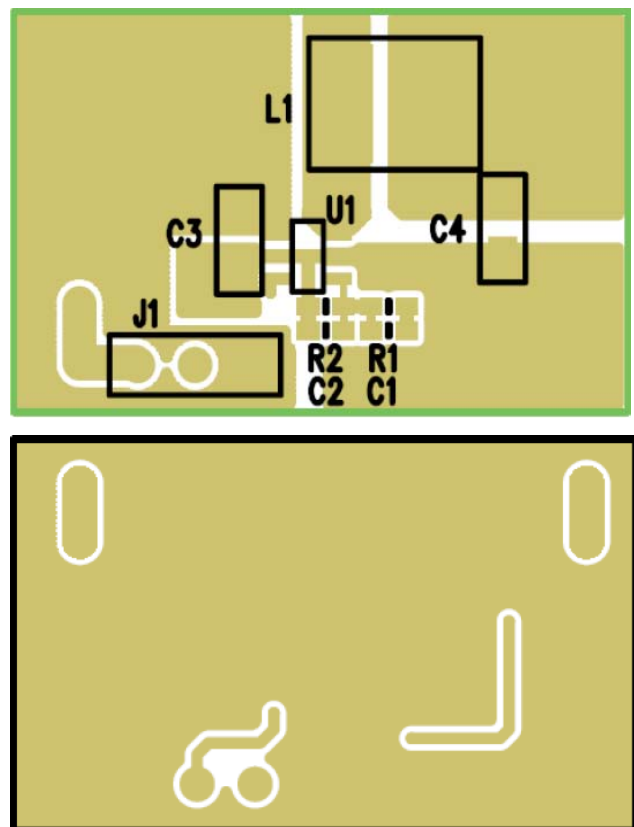

Figure 9. ATI2305 Suggested Layout

TYPICAL PERFORMANCE CHARACTERISTICS



T_A=25°C, C_{IN}=10µF, C_O=10µF, L=4.7µH, unless otherwise noted.

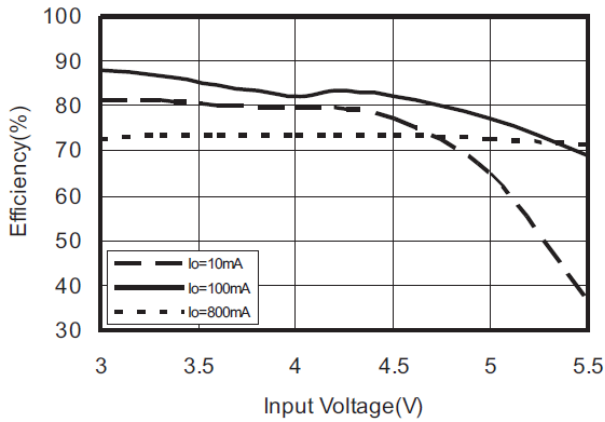

Figure 10. Efficiency VS Input Voltage (V_O=1.2V)

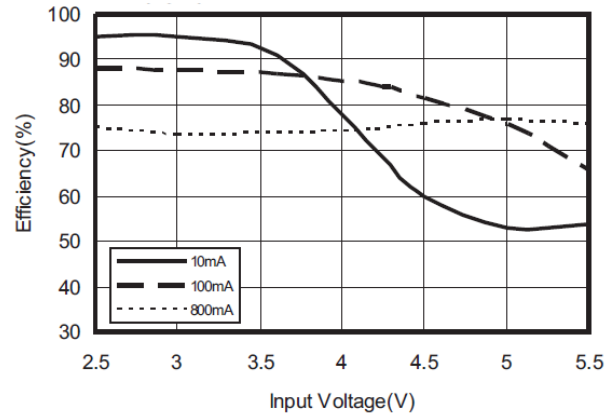

Figure 11. Efficiency VS Input Voltage (V_O=1.5V)

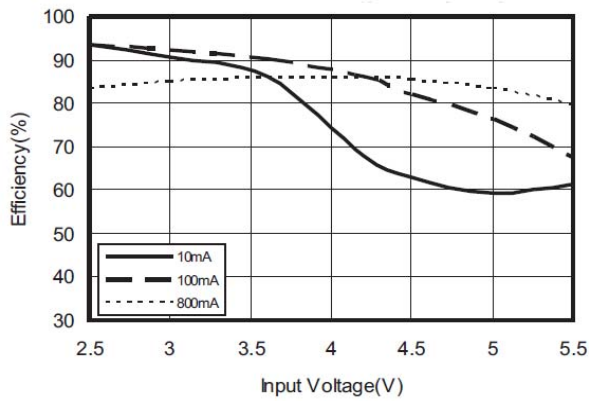

Figure 12. Efficiency VS Input Voltage (V_O=1.8V)

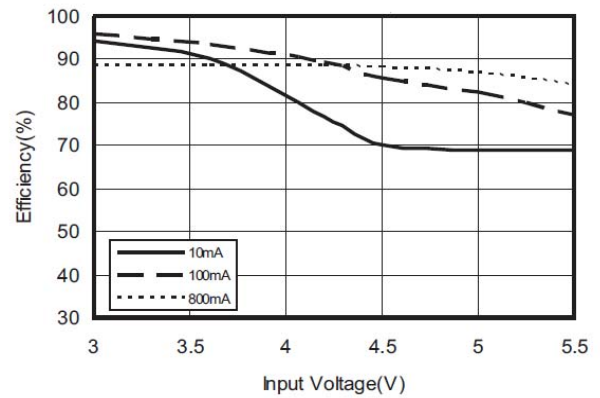

Figure 13. Efficiency VS Input Voltage (V_O=2.5V)

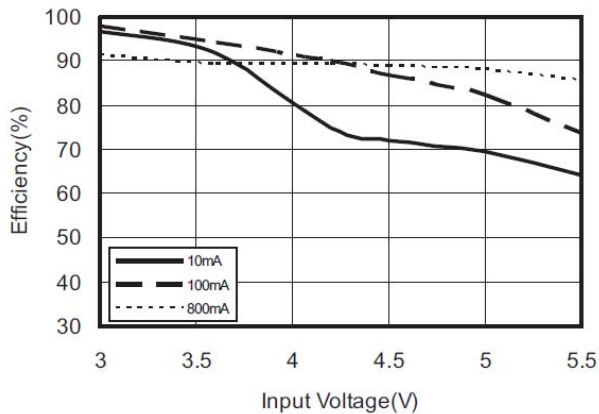

Figure 14. Efficiency VS Input Voltage (V_O=2.8V)

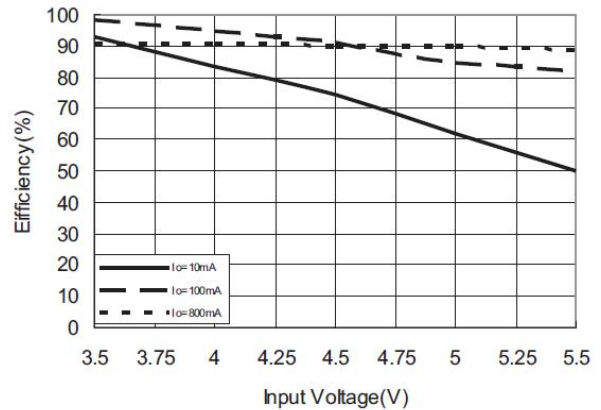

Figure 15. Efficiency VS Input Voltage (V_O=3.3V)



T_A=25°C, C_{IN}=10µF, C_O=10µF, L=4.7µH, unless otherwise noted.

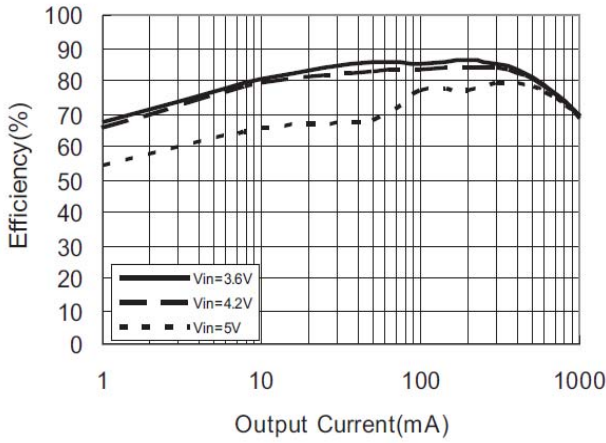

Figure 16. Efficiency VS Output Current (V_O=1.2V)

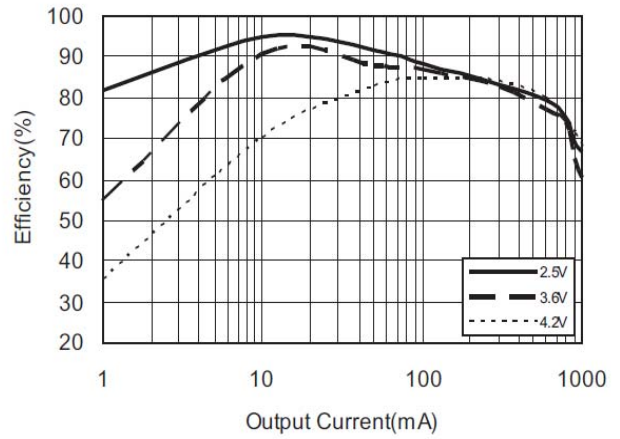

Figure 17. Efficiency VS Output Current (V_O=1.5V)

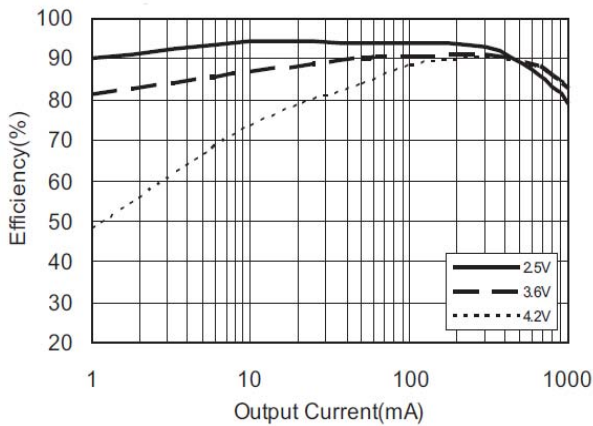

Figure 18. Efficiency VS Output Current (V_O=1.8V)

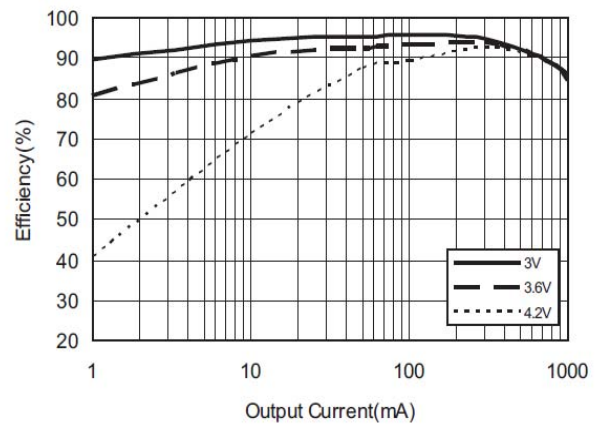

Figure 19. Efficiency VS Output Current (V_O=2.5V)

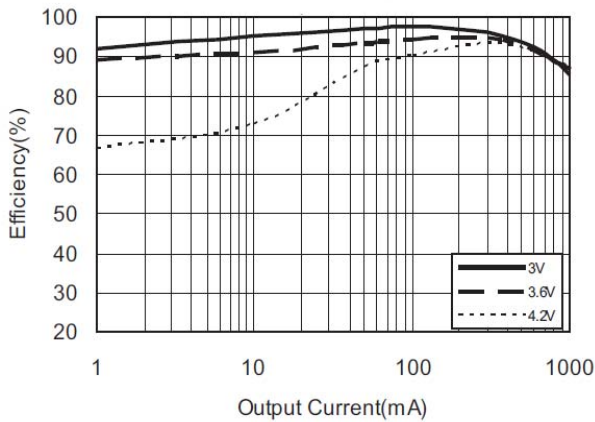

Figure 20. Efficiency VS Output Current (V_O=2.8V)

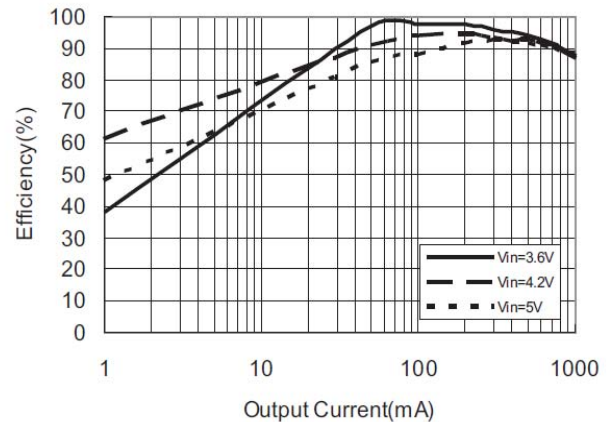

Figure 21. Efficiency VS Output Current (V_O=3.3V)



T_A=25°C, C_{IN}=10µF, C_O=10µF, L=4.7µH, unless otherwise noted.

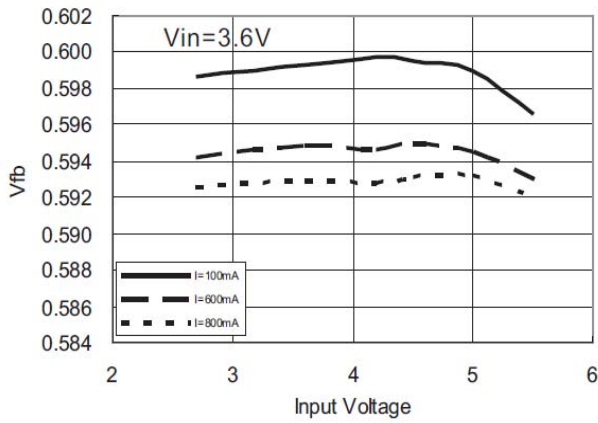

Figure 22. Reference Voltage VS Input Voltage

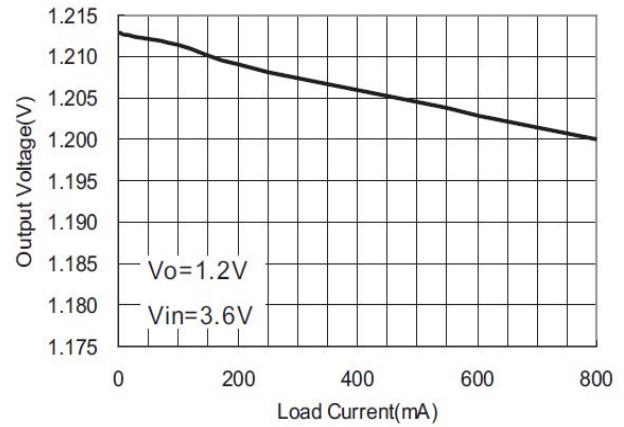

Figure 23. Output Voltage VS Load Current

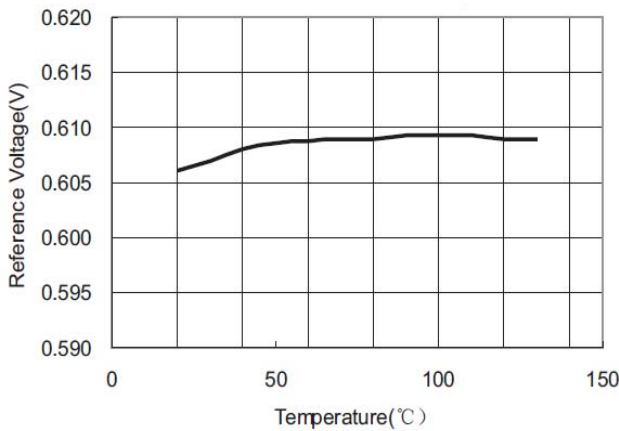

Figure 24. Reference Voltage VS Temperature

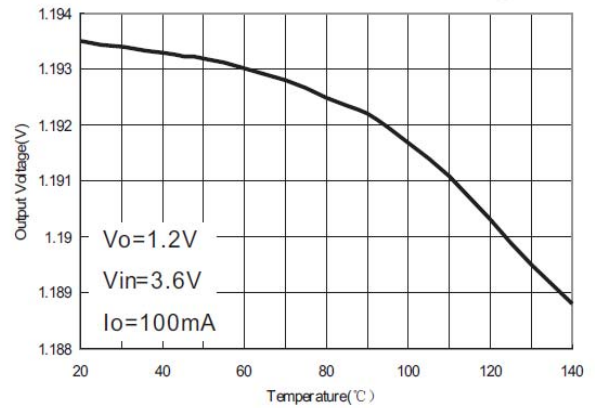

Figure 25. Output Voltage VS Temperature

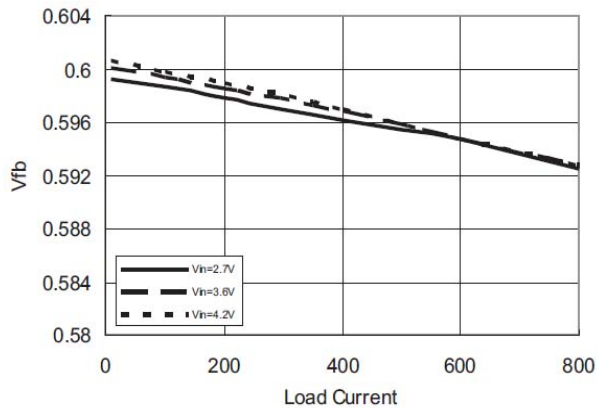

Figure 26. Reference Voltage VS Load Current

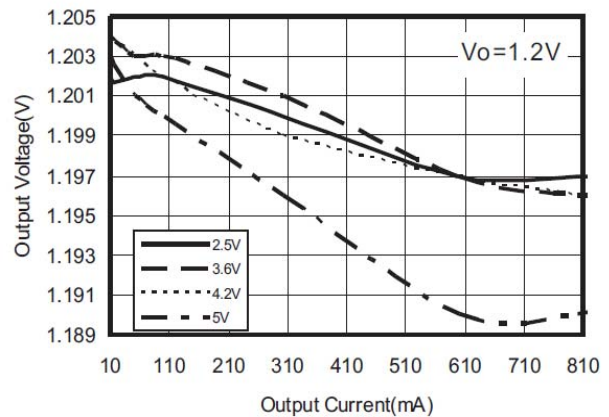

Figure 27. Output Voltage VS Output Current



T_A=25°C, C_{IN}=10µF, C_O=10µF, L=4.7µH, unless otherwise noted.

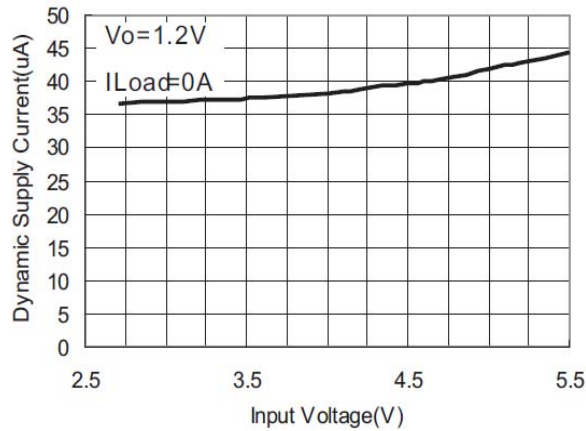

Figure 28. Dynamic Supply Current VS Input Voltage

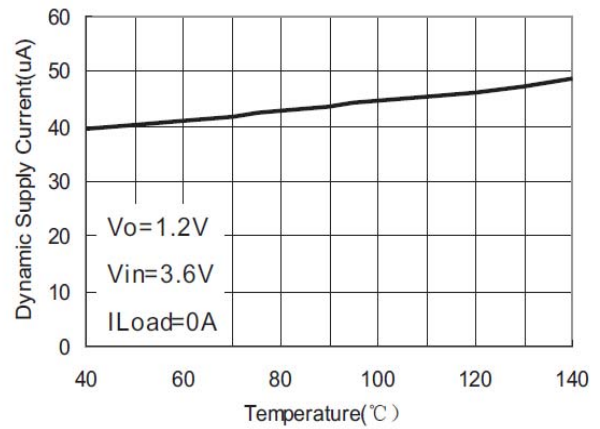

Figure 29. Dynamic Supply Current VS Temperature

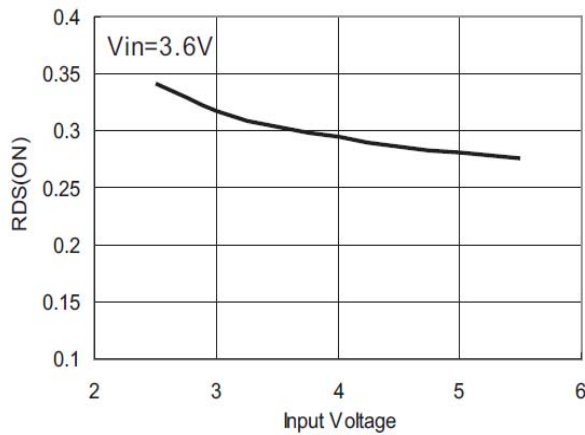

Figure 30. Rds(on) VS Input Voltage

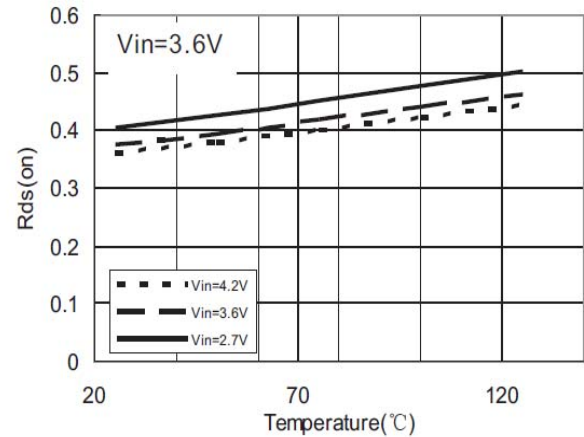

Figure 31. Rds(on) VS Temperature

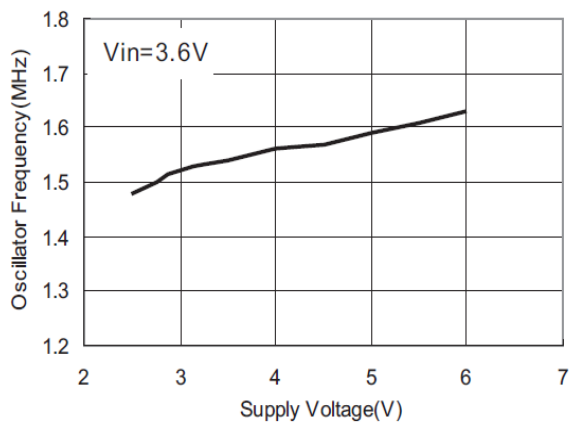

Figure 32. Oscillator Frequency VS Supply Voltage

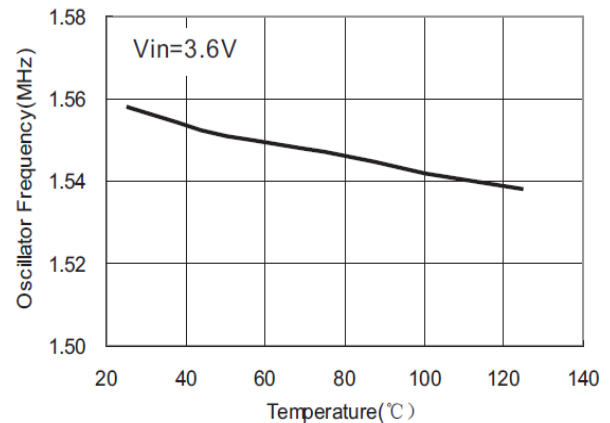

Figure 33. Oscillator Frequency VS Temperature

$T_A=25^{\circ}\text{C}$, $C_{IN}=10\mu\text{F}$, $C_O=10\mu\text{F}$, $L=4.7\mu\text{H}$, unless otherwise noted.

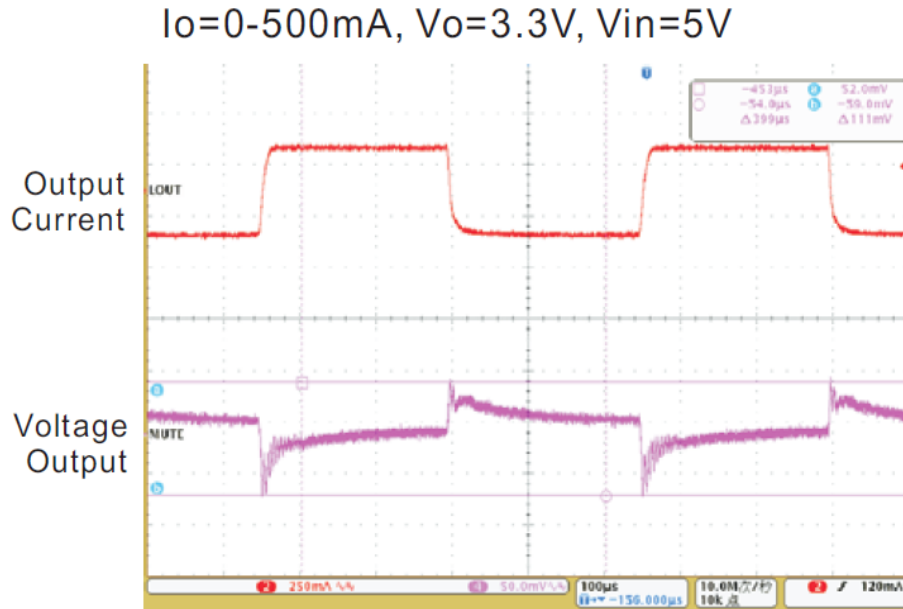

Figure 34. Load Transient

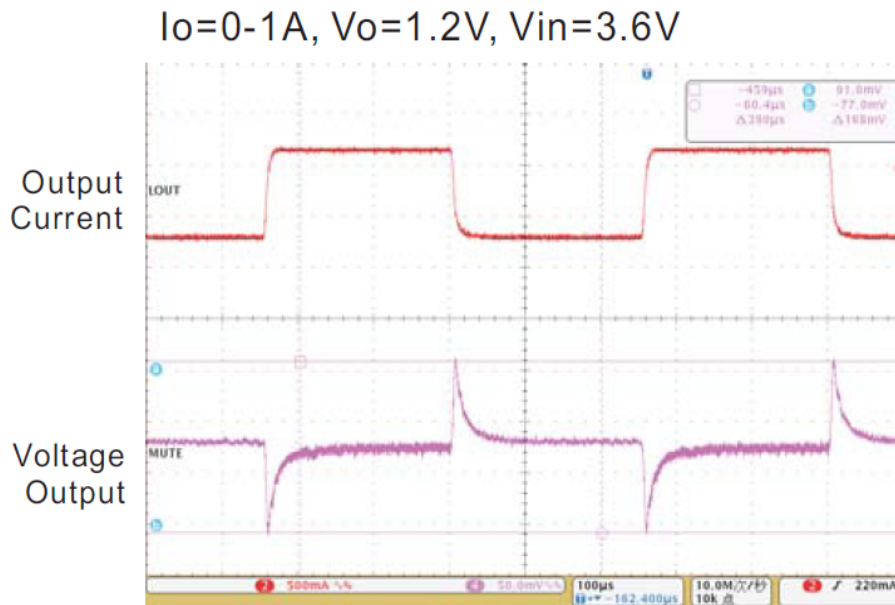

Figure 35. Load Transient

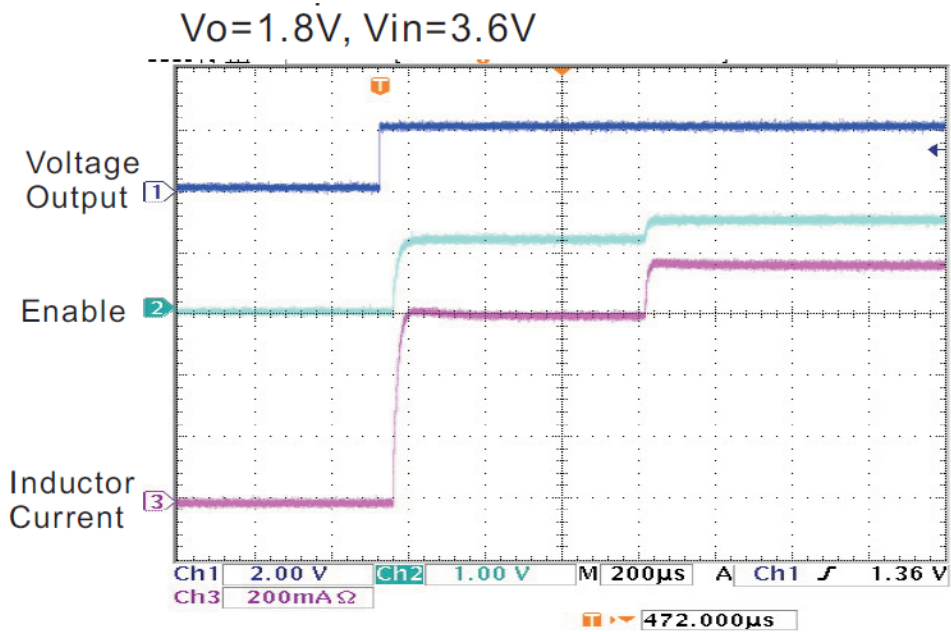

Figure 36. Start-up from Shutdown

PART NUMBER

ATI2305 X X X X

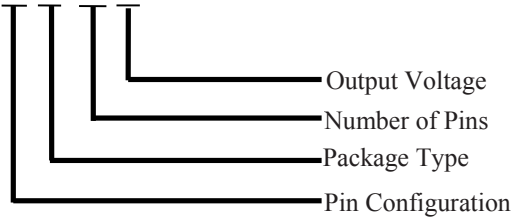

Table 5.

Pin Configuration	Package Type	Number of Pins	Output Voltage
A Type			
1. VIN			330: 3.3V
2. GND	A: SOT-23	B: 5	280: 2.8V
3. EN	J: QFN 3×3	E: 16	250: 2.5V
4. VOUT/FB	G: DFN 2×2	F: 6	180: 1.8V
5. SW			150: 1.5V
B Type			120: 1.2V
16 pins			ADJ: Adjustable
C Type			
1. NC			
2. EN			
3. VIN			
4. SW			
5. GND			
6. VOUT/FB			



PURCHASING INFORMATION

Table 6.

Part Number	Output Voltage	Marking	Package Type	Standard Package
ATI2305AAB330	3.3V	BEKYW	SOT-23-5	3000Units/Tape&Reel
ATI2305AAB280	2.8V	BEHYW	SOT-23-5	3000Units/Tape&Reel
ATI2305AAB250	2.5V	BEGYW	SOT-23-5	3000Units/Tape&Reel
ATI2305AAB180	1.8V	BEEYW	SOT-23-5	3000Units/Tape&Reel
ATI2305AAB150	1.5V	BECYW	SOT-23-5	3000Units/Tape&Reel
ATI2305AAB120	1.2V	BEBYW	SOT-23-5	3000Units/Tape&Reel
ATI2305AABADJ	ADJ	BEAYW	SOT-23-5	3000Units/Tape&Reel
ATI2305BJE330	3.3V	P2305K	QFN3×3	3000Units/Tape&Reel
ATI2305BJE280	2.8V	P2305H	QFN3×3	3000Units/Tape&Reel
ATI2305BJE250	2.5V	P2305G	QFN3×3	3000Units/Tape&Reel
ATI2305BJE180	1.8V	P2305E	QFN3×3	3000Units/Tape&Reel
ATI2305BJE150	1.5V	P2305C	QFN3×3	3000Units/Tape&Reel
ATI2305BJE120	1.2V	P2305B	QFN3×3	3000Units/Tape&Reel
ATI2305BJEADJ	ADJ	P2305A	QFN3×3	3000Units/Tape&Reel
ATI2305CGF330	3.3V	BEKYW	DFN2×2-6	3000Units/Tape&Reel
ATI2305CGF280	2.8V	BEHYW	DFN2×2-6	3000Units/Tape&Reel
ATI2305CGF250	2.5V	BEGYW	DFN2×2-6	3000Units/Tape&Reel
ATI2305CGF180	1.8V	BEEYW	DFN2×2-6	3000Units/Tape&Reel
ATI2305CGF150	1.5V	BECYW	DFN2×2-6	3000Units/Tape&Reel
ATI2305CGF120	1.2V	BEBYW	DFN2×2-6	3000Units/Tape&Reel
ATI2305CGFADJ	ADJ	BEAYW	DFN2×2-6	3000Units/Tape&Reel

DIMENSIONS

SOT 23-5

Table 7.

REF	Millimeter	
	Min	Max
A	1.10MAX	
A1	0	0.10
A2	0.70	1
c	0.12REF	
D	2.70	3.10
E	2.60	3.00
E1	1.40	1.80
L	0.45REF	
L1	0.60REF	
θ	0°	10°
b	0.30	0.50
e	0.95REF	
e l	1.90REF	

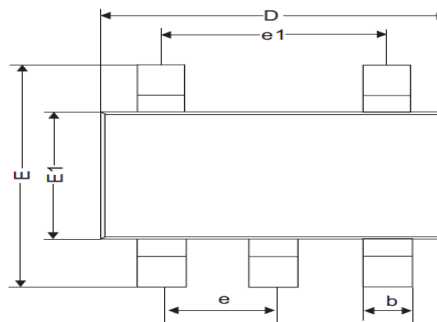

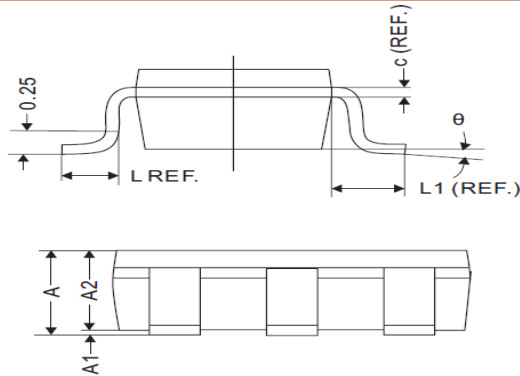

DFN 2x2

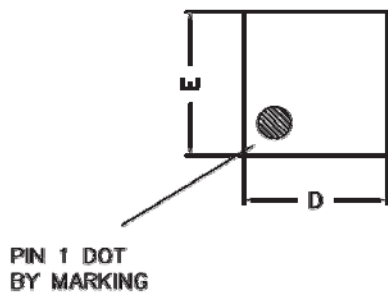

PIN 1 DOT BY MARKING

Figure 37. Top View

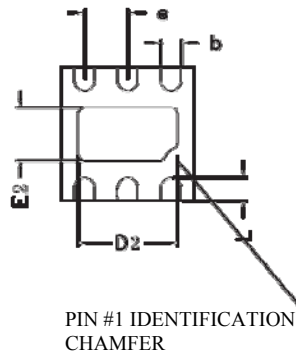

PIN #1 IDENTIFICATION CHAMFER

Figure 38. Bottom View

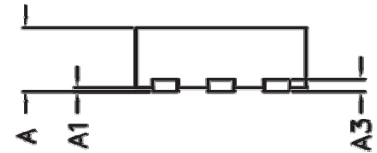

Figure 39. Side View

Table 8.

COMMON DIMENSIONS (MM)			
PKG	W: VERY VERY THIN		
REF	MIN	NOM	MAX
A	0.70	0.75	0.80
A1	0.00	-	0.05
A3	0.2 REF		
D	1.95	2.00	2.05
E	1.95	2.00	2.05
b	0.25	0.30	0.35
L	0.25	0.35	0.45
D2	1.35	1.50	1.60
E2	0.65	0.80	0.90
e	0.65 BSC		



3x3mm QFN 16

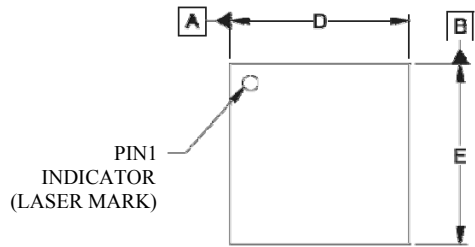

Figure 40. Top View

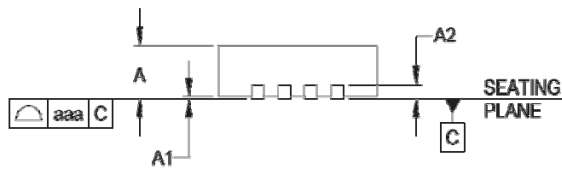

Figure 41. Side View

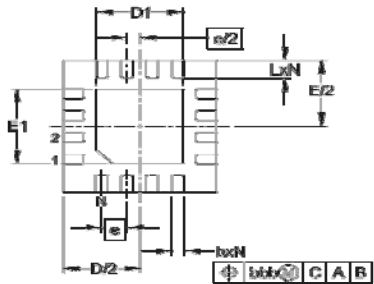

Figure 42. Bottom View

Table 9.

DIMENSIONS (Millimeters)			
	MIN	TYP	MAX
A	0.70	0.75	0.80
A1	0.00	0.02	0.05
A2	0.20		
b	0.18	0.25	0.30
D	2.90	3.00	3.10
D1	1.55	1.70	1.80
E	2.90	3.00	3.10
E1	1.55	1.70	1.80
e	0.50BSC		
L	0.30	0.40	0.50
N	16		
aaa	0.08		
bbb	0.10		

NOTES:

1. Controlling dimensions are in millimeters (angles in degrees).
2. Coplanarity applies to the exposed pad as well as the terminals.
3. Dap is 1.90 × 1.90mm.



NOTICE

1. ATI reserves the right to make changes to its products or to discontinue any product or service without notice, and advise customers to obtain the latest version of relevant information to verify, before placing orders, that information being relied on is current and complete.
2. All products are sold subject to the terms and conditions of sale supplied at the time of order acknowledgment, including those pertaining to warranty, patent infringement, and limitation of liability. Testing and other quality control techniques are utilized to the extent ATI deems necessary to support this warranty. Specific testing of all parameters of each device is not necessarily performed, except those mandated by government requirements.
3. Customers are responsible for their applications using ATI components. In order to minimize risks associated with the customers' applications, adequate design and operating safeguards must be provided by the customers to minimize inherent or procedural hazards. ATI assumes no liability for applications assistance or customer product design.
4. ATI does not warrant or represent that any license, either express or implied, is granted under any patent right, copyright, mask work right, or other intellectual property right of ATI covering or relating to any combination, machine, or process in which such products or services might be or are used. ATI's publication of information regarding any third party's products or services does not constitute ATI's approval, warranty or endorsement thereof.
5. IP (Intellectual Property) Ownership: ATI retains the ownership of full rights for special technologies and/or techniques embedded in its products, the designs for mechanics, optics, plus all modifications, improvements, and inventions made by ATI for its products and/or projects.