

1/2.7-Inch 2.1 Mp/Full HD Digital Image Sensor

AR0237/D, Rev. 4

For the latest datasheet, please visit www.onsemi.com

Features

- Superior low-light performance
- Latest 3.0 μm pixel with ON Semiconductor DR-Pix™ technology with Dual Conversion Gain
- Full HD support at up to 1080P 60 fps for superior video performance
- Linear or high dynamic range capture
- Supports line interleaved T1/T2 readout to enable HDR processing in ISP chip
- Support for external mechanical shutter
- On-chip phase-locked loop (PLL) oscillator
- Integrated position-based color and lens shading correction
- Slave mode for precise frame-rate control
- Stereo/3D camera support
- Statistics engine
- Data interfaces: four-lane serial high-speed pixel interface (HiSPi) differential signaling (SLVS and HiVCM), or parallel
- Auto black level calibration
- High-speed configurable context switching
- Temperature sensor

Applications

- Video surveillance
- 1080p60 (Surveillance) video applications
- High dynamic range imaging

General Description

ON Semiconductor's AR0237 is a 1/2.7-inch CMOS digital image sensor with an active-pixel array of 1928Hx1088V. It captures images in either linear or high dynamic range modes, with a rolling-shutter readout. It includes sophisticated camera functions such as in-pixel binning, windowing and both video and single frame modes. It is designed for both low light and high dynamic range scene performance. It is programmable through a simple two-wire serial interface. The AR0237 produces extraordinarily clear, sharp digital pictures, and its ability to capture both continu-

ous video and single frames makes it the perfect choice for a wide range of applications, including surveillance and HD video.

Table 1: Key Parameters

Parameter	Typical Value	
Optical format	1/2.7-inch (6.6 mm)	
Active pixels	1928(H) x 1088(V) (16:9 mode)	
Pixel size	3.0 μm x 3.0 μm	
Color filter array	RGB Bayer, RGB-IR	
Shutter type	Electronic rolling shutter and GRR	
Input clock range	6 – 48 MHz	
Output clock maximum	148.5 Mp/s (4-lane HiSPi) 74.25 Mp/s (Parallel)	
Output	Serial	HiSPi 10-, 12-, 14-, 16-, or 20-bit
	Parallel	10-, 12-bit
Frame rate	1080p	60 fps Linear HiSPi
		30 fps Linear Parallel
		30 fps Line Interleaved HiSPi
		15 fps Line Interleaved Parallel
Responsivity	4.0 V/lux-sec	
SNR _{MAX}	41 dB	
Max Dynamic range	Up to 96 dB	
Supply voltage	I/O	1.8 or 2.8 V
	Digital	1.8 V
	Analog	2.8 V
	HiSPi	0.3 V - 0.6 V (SLVS), 1.7 V - 1.9 V (HiVcm)
Power consumption (typical)	< 300mW Line interleaved 1080p30 <190mW 1080p30 Linear Mode	
Operating temperature	–30°C to +85°C ambient	
Package options	10x10 mm 80-pin iBGA 11.43x11.43 mm 48-pin mPLCC	

Ordering Information

Table 2: Available Part Numbers

Part Number	Product Description	Orderable Product Attribute Description
AR0237CSSC00SUEA0-DR	2Mp 1/2.7" Image Sensor, RGB, 0 deg CRA, iBGA package, multi output	Drypack
AR0237CSSC00SHRA0-DR	2Mp 1/2.7" Image Sensor, RGB, 0 deg CRA, mPLCC package, HiSPi output	Drypack
AR0237CSSC00SPRA0-DR	2Mp 1/2.7" Image Sensor, RGB, 0 deg CRA, mPLCC package, Parallel output	Drypack
AR0237CSSC12SHRA0-DR	2Mp 1/2.7" Image Sensor, RGB, 12 deg CRA, mPLCC package, HiSPi output	Drypack
AR0237CSSC12SPRA0-DR	2Mp 1/2.7" Image Sensor, RGB, 12 deg CRA, mPLCC package, Parallel output	Drypack
AR0237IRSH12SHRA0-DR-E	2Mp 1/2.7" Image Sensor, RGB-IR, 12 deg CRA, mPLCC package, HiSPi output	Drypack
AR0237IRSH12SPRA0-DR-E	2Mp 1/2.7" Image Sensor, RGB-IR, 12 deg CRA, mPLCC package, Parallel output	Drypack
AR0237CSSC00SUEAH3-GEVB	RGB, 0 deg CRA, iBGA package, multi output, Headboard	Headboard
AR0237CSSC00SHRAH3-GEVB	RGB, 0 deg CRA, mPLCC package, HiSPi output, Headboard	Headboard
AR0237CSSC00SPRAH3-GEVB	RGB, 0 deg CRA, mPLCC package, Parallel output, Headboard	Headboard
AR0237CSSC12SHRAH3-GEVB	RGB, 12 deg CRA, mPLCC package, HiSPi output, Headboard	Headboard
AR0237CSSC12SPRAH3-GEVB	RGB, 12 deg CRA, mPLCC package, Parallel output, Headboard	Headboard
AR0237IRSH12SHRAH3-GEVB	RGB-IR, 12 deg CRA, mPLCC package, HiSPi output, Headboard	Headboard
AR0237IRSH12SPRAH3-GEVB	RGB-IR, 12 deg CRA, mPLCC package, Parallel output, Headboard	Headboard

See the ON Semiconductor Device Nomenclature document (TND310/D) for a full description of the naming convention used for image sensors. For reference documentation, including information on evaluation kits, please visit our web site at www.onsemi.com.

Table of Contents

Features	1
Applications	1
General Description	1
Ordering Information	2
General Description	5
Functional Overview	6
Pixel Data Format	16
Features Overview	19
Electrical Specifications	26
Power-On Reset and Standby Timing	33



General Description

The ON Semiconductor AR0237 can be operated in its default mode or programmed for frame size, exposure, gain, and other parameters. The default mode output is a 1080p-resolution image at 60 frames per second (fps) through the HiSPi port. In linear mode, it outputs 12-bit or 10-bit A-Law compressed raw data, using either the parallel or serial (HiSPi) output ports. In high dynamic range mode, it outputs two exposure values that the ISP will combine into an HDR image. The device may be operated in video (master) mode or in single frame trigger mode.

FRAME_VALID and LINE_VALID signals are output on dedicated pins, along with a synchronized pixel clock in parallel mode.

The AR0237 includes additional features to allow application-specific tuning: windowing and offset, auto black level correction, and on-board temperature sensor. Optional register information and histogram statistic information can be embedded in the first and last 2 lines of the image frame.

The AR0237 is designed to operate over a wide temperature range of -30°C to +85°C ambient.

Functional Overview

The AR0237 is a progressive-scan sensor that generates a stream of pixel data at a constant frame rate. It uses an on-chip, phase-locked loop (PLL) that can be optionally enabled to generate all internal clocks from a single master input clock running between 6 and 48 MHz. The maximum output pixel rate is 148.5 Mp/s, corresponding to a clock rate of 74.25 MHz. Figure 1 shows a block diagram of the sensor configured in linear mode, and in HDR mode.

Figure 1: Block Diagram of AR0237

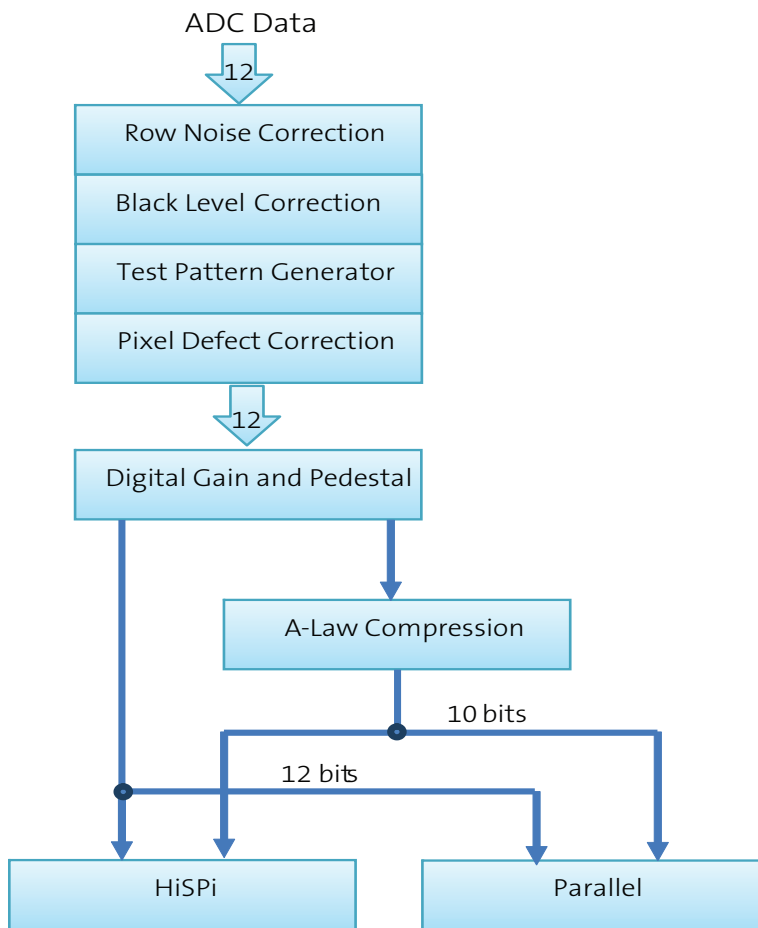

User interaction with the sensor is through the two-wire serial bus, which communicates with the array control, analog signal chain, and digital signal chain. The core of the sensor is a 2.1 Mp Active-Pixel Sensor array. The timing and control circuitry sequences through the rows of the array, resetting and then reading each row in turn. In the time interval between resetting a row and reading that row, the pixels in the row integrate incident light. The exposure is controlled by varying the time interval between reset and readout. Once a row has been read, the data from the columns is sequenced through an analog signal chain (providing offset correction and gain), and then through an analog-to-digital converter (ADC). The output from the ADC is a 12-bit value for each pixel in the array. The ADC output passes through a digital processing chain (which provides further data path corrections and applies digital gain). The sensor also offers a

high dynamic range mode of operation where two images are taken using different exposures. These images are output from the sensor and the ISP must combine them into one high dynamic range image.

Figure 2: Typical Configuration: Serial Four-Lane HiSpi Interface

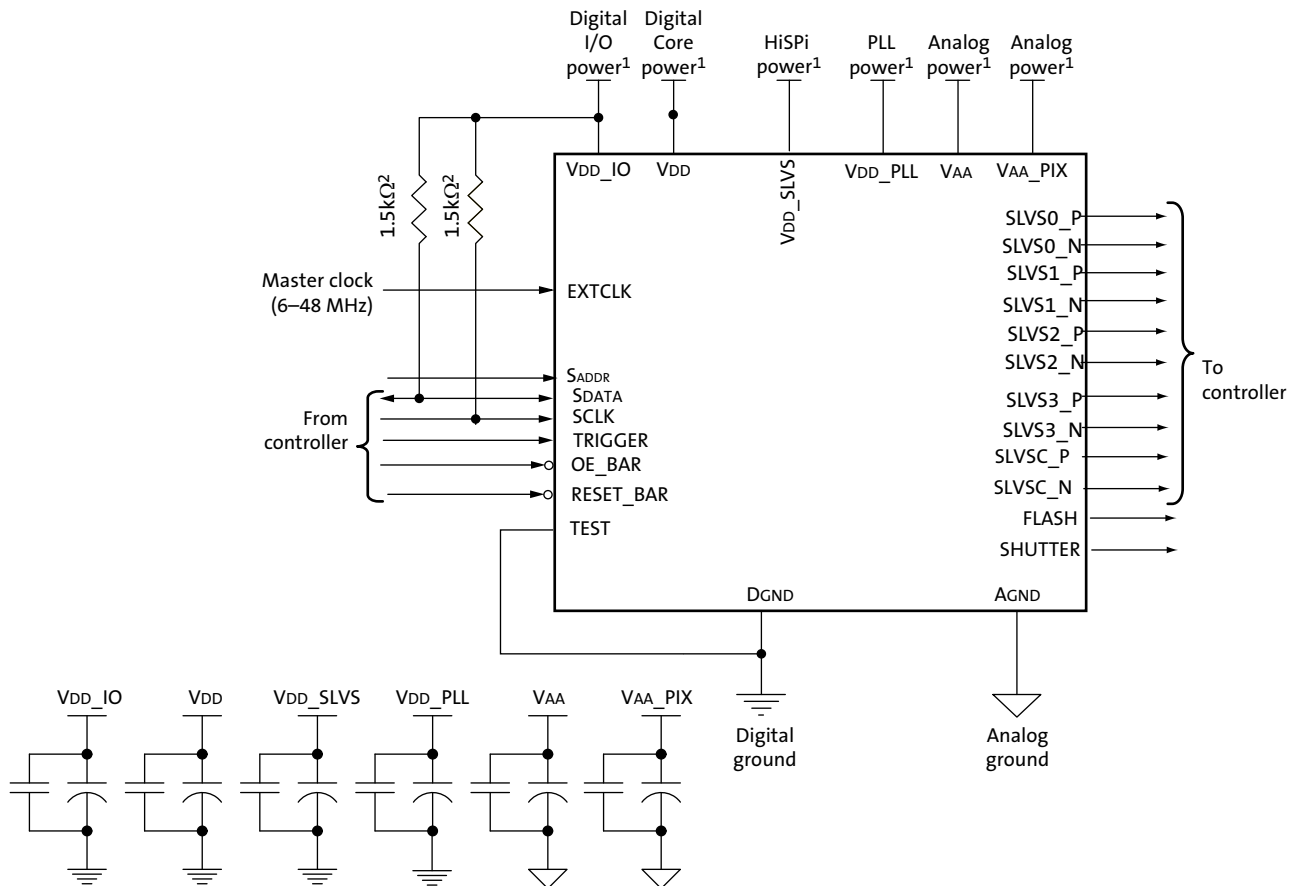

- Notes:
1. All power supplies must be adequately decoupled.
 2. ON Semiconductor recommends a resistor value of 1.5kΩ, but a greater value may be used for slower two-wire speed.
 3. The parallel interface output pads can be left unconnected if the serial output interface is used.
 4. ON Semiconductor recommends that 0.1μF and 10μF decoupling capacitors for each power supply are mounted as close as possible to the pad. Actual values and results may vary depending on layout and design considerations. Refer to the AR0237 demo headboard schematics for circuit recommendations.
 5. ON Semiconductor recommends that analog power planes are placed in a manner such that coupling with the digital power planes is minimized.
 6. I/O signals voltage must be configured to match VDD_IO voltage to minimize any leakage currents.

Figure 3: Typical Configuration: Parallel Pixel Data Interface

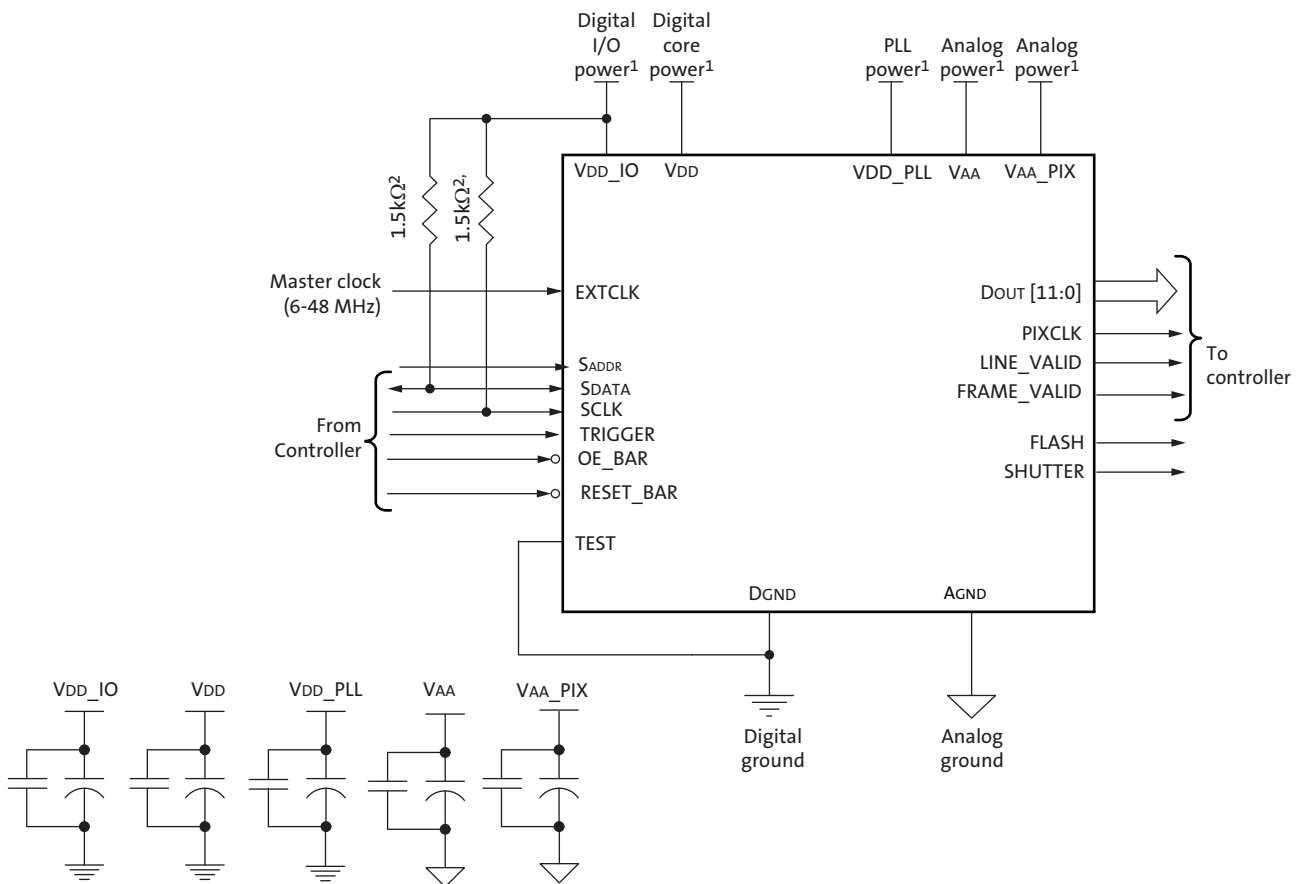

- Notes:
1. All power supplies must be adequately decoupled.
 2. ON Semiconductor recommends a resistor value of 1.5kΩ, but a greater value may be used for slower two-wire speed.
 3. The serial interface output pads and VDDSLVS can be left unconnected if the parallel output interface is used.
 4. ON Semiconductor recommends that 0.1μF and 10μF decoupling capacitors for each power supply are mounted as close as possible to the pad. Actual values and results may vary depending on layout and design considerations. Refer to the AR0237 demo headboard schematics for circuit recommendations.
 5. ON Semiconductor recommends that analog power planes are placed in a manner such that coupling with the digital power planes is minimized.
 6. I/O signals voltage must be configured to match VDD_IO voltage to minimize any leakage currents.
 7. The EXTCLK input is limited to 6-48 MHz.

Figure 4: 80-Ball IBGA Package

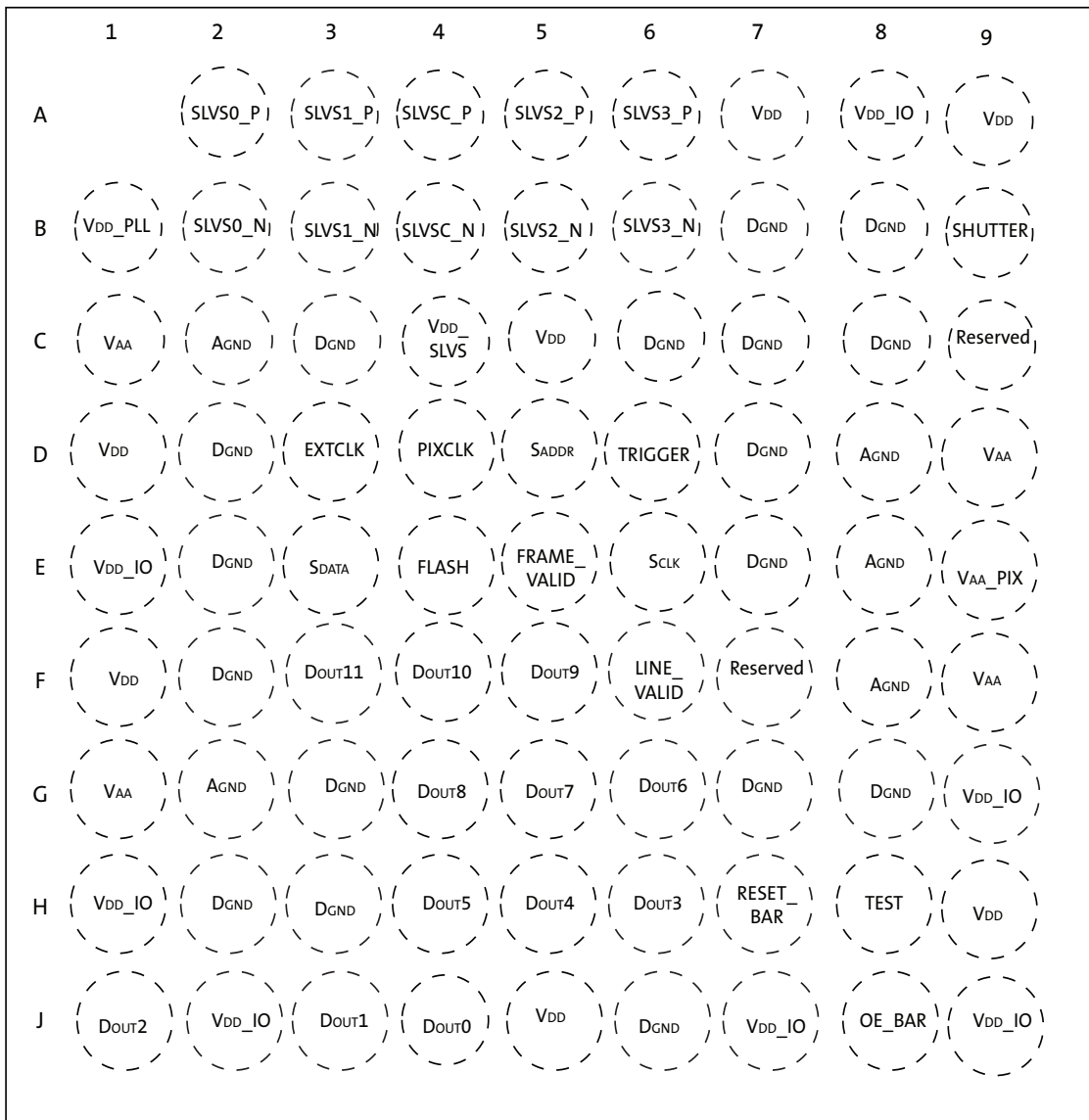

Top View
(Ball Down)

Table 3: Pin Descriptions, 80-ball iBGA

Name	iBGA Pin	Type	Description
SLVS0_P	A2	Output	HiSPi serial data, lane 0, differential P.
SLVS1_P	A3	Output	HiSPi serial data, lane 1, differential P.
SLVSC_P	A4	Output	HiSPi serial DDR clock differential P.
SLVS2_P	A5	Output	HiSPi serial data, lane 2, differential P.
SLVS3_P	A6	Output	HiSPi serial data, lane 3, differential P.
VDD_PLL	B1	Power	PLL power.
SLVS0_N	B2	Output	HiSPi serial data, lane 0, differential N.
SLVS1_N	B3	Output	HiSPi serial data, lane 1, differential N.
SLVSC_N	B4	Output	HiSPi serial DDR clock differential N.
SLVS2_N	B5	Output	HiSPi serial data, lane 2, differential N.
SLVS3_N	B6	Output	HiSPi serial data, lane 3, differential N.
SHUTTER	B9	Output	Control for external mechanical shutter. Can be left floating if not used.
VAA	C1, G1, D9, F9	Power	Analog power.
AGND	C2, G2, D8, E8, F8	Power	Analog ground.
VDD_SLVS	C4	Power	SLVS Power
VDD	C5, J5, A9, H9, A7, D1, F1	Power	Digital power.
Reserved	C9, F7		
DGND	B7, C7, D7, E7, G7, B8, C8, G8, D2, E2, F2, H2, C3, G3, H3, C6, J6	Power	Digital ground.
EXTCLK	D3	Input	External input clock.
PIXCLK	D4	Output	Pixel clock out. Dout is valid on rising edge of this clock.
SADDR	D5	Input	Two-Wire Serial address select. 0: 0x20. 1: 0x30
TRIGGER	D6	Input	Exposure synchronization input.
VAA_PIX	E9	Power	Pixel power.
VDD_IO	E1, H1, J2, J7, A8, G9, J9	Power	I/O supply power.
SDATA	E3	I/O	Two-Wire Serial data I/O.
FLASH	E4	Output	Flash control output.
FRAME_VALID	E5	Output	Asserted when Dout frame data is valid.
SCLK	E6	Input	Two-Wire Serial clock input.
DOUT11	F3	Output	Parallel pixel data output (MSB)
DOUT10	F4	Output	Parallel pixel data output.
DOUT9	F5	Output	Parallel pixel data output.
LINE_VALID	F6	Output	Asserted when Dout line data is valid.
DOUT8	G4	Output	Parallel pixel data output.
DOUT7	G5	Output	Parallel pixel data output.
DOUT6	G6	Output	Parallel pixel data output.
DOUT5	H4	Output	Parallel pixel data output.
DOUT4	H5	Output	Parallel pixel data output.
DOUT3	H6	Output	Parallel pixel data output.
RESET_BAR	H7	Input	Asynchronous reset (active LOW). All settings are restored to factory default.
TEST	H8	Input.	Manufacturing test enable pin (connect to Dgnd).

Table 3: Pin Descriptions, 80-ball iBGA

Name	iBGA Pin	Type	Description
DOUT2	J1	Output	Parallel pixel data output.
DOUT1	J3	Output	Parallel pixel data output.
DOUT0	J4	Output	Parallel pixel data output (LSB)
OE_BAR	J8	Input	Output enable (active LOW).

Figure 5: 48 Pin mPLCC Package HiSPi

	6	5	4	3	2	1	48	47	46	45	44	43	
	VDD0V4_PHY	SLVSON	SLVS0P	SLVS1N	SLVS1P	SLVSON	SLVSLCP	SLVS2N	SLVS2P	SLVS3N	SLVS3P	VDD1V8_PHY	
7	DGND											VDDIO2V8R1V8	42
8	VDDIO2V8R1V8_PLL											DVDD1V8	41
9	EXTCLK											DGND	40
10	VAA2V8											AGND	39
11	AGND											VAA2V8_PIX	38
12	VDDIO2V8R1V8											VAA2V8	37
13	DVDD1V8											RESERVED	36
14	DGND											VAA2V8	35
15	RESERVED											VAA2V8_PIX	34
16	VAA2V8											AGND	33
17	AGND											DGND	32
18	DGND											DVDD1V8	31
	DVDD1V8	VDDIO2V8R1V8	FLASH	TEST	SDA	SADDR	SCL	RESET_N	OUTPUT_ENABLE_N	TRIGGER	SHUTTER	VDDIO2V8R1V8	
	19	20	21	22	23	24	25	26	27	28	29	30	

TOP SIDE VIEW

Table 4: mPLCC HiSPi Pin Out

Pin	Name	Type	Description
1	SLVSCN	Output	HiSPi serial DDR clock differential N
2	SLVS1P	Output	HiSPi serial data, lane 1, differential P
3	SLVS1N	Output	HiSPi serial data, lane 1, differential N
4	SLVS0P	Output	HiSPi serial data, lane 0, differential P
5	SLVS0N	Output	HiSPi serial data, lane 0, differential N
6	VDD_SLVS	Power	SLVS Power 0.3 V-0.6 V
7	DGND	Power	Digital ground
8	VDD_PLL	Power	PLL power
9	EXTCLK	Input	External input clock
10	VAA	Power	Analog Power
11	AGND	Power	Analog Ground
12	VDD_IO	Power	I/O Power Supply
13	VDD	Power	Digital Power
14	DGND	Power	Digital ground
15	Reserved		
16	VAA	Power	Analog Power
17	AGND	Power	Analog Ground
18	DGND	Power	Digital ground
19	VDD	Power	Digital Power
20	VDD_IO	Power	I/O Power Supply
21	FLASH	Output	Flash control output
22	TEST	Input	Manufacturing test enable pin (connect to DGNG)
23	SDATA	I/O	Two-Wire Serial data I/O
24	SADDR	Input	Two-Wire Serial address select. 0: 0x20, 1: 0x30
25	SCLK	Input	Two-Wire Serial clock input
26	RESET_BAR	Input	Asynchronous reset (active LOW). All settings are restored to factory default
27	OE_BAR	Input	Output enable (active LOW)
28	TRIGGER	Input	Exposure synchronization input
29	SHUTTER	Output	Control for external mechanical shutter. Can be left floating if not used.
30	VDD_IO	Power	I/O Power Supply
31	VDD	Power	Digital Power
32	DGND	Power	Digital ground
33	AGND	Power	Analog Ground
34	VAA_PIX	Power	Pixel Power
35	VAA	Power	Analog Power
36	Reserved		
37	VAA	Power	Analog Power
38	VAA_PIX	Power	Pixel Power
39	AGND	Power	Analog Ground

**Table 4: mPLCC HiSPi Pin Out**

40	DGND	Power	Digital ground
41	VDD	Power	Digital Power
42	VDD_IO	Power	I/O Power Supply
43	VDD 1V8_PHY	Power	1.8 V supply for HiVcm mode
44	SLSV3P	Output	HiSPi serial data, lane 3, differential P
45	SLVS3N	Output	HiSPi serial data, lane 3, differential N
46	SLVS2P	Output	HiSPi serial data, lane 2, differential P
47	SLVS2N	Output	HiSPi serial data, lane 2, differential N
48	SLVSLCP	Output	HiSPi serial DDR clock differential P

Figure 6: 48 Pin mPLCC Package Parallel

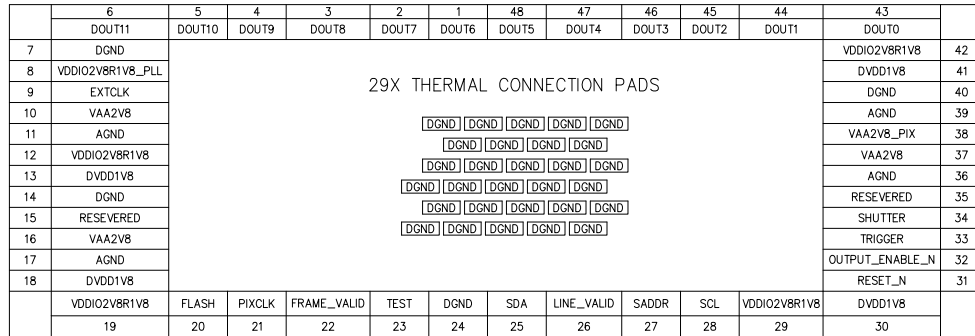

TOP SIDE VIEW

Table 5: mPLCC Parallel Pin Out

Pin	Name	Type	Description
1	DOUT6	Output	Data output 6
2	DOUT7	Output	Data output 7
3	DOUT8	Output	Data output 8
4	DOUT9	Output	Data output 9
5	DOUT10	Output	Data output 10
6	DOUT11	Power	Data output 11
7	DGND	Power	Digital ground
8	VDD_PLL	Power	PLL power
9	EXTCLK	Input	External input clock
10	VAA	Power	Analog Power
11	AGND	Power	Analog Ground
12	VDD_IO	Power	I/O Power Supply
13	VDD	Power	Digital Power
14	DGND	Power	Digital ground
15	Reserved		
16	VAA	Power	Analog Power
17	AGND	Power	Analog Ground
18	VDD	Power	Digital Power
19	VDD_IO	Power	I/O Power Supply
20	FLASH	Power	Flash control output
21	PIXCLK	Output	Pixel Clock
22	FRAME_VALID	Output	Frame Valid
23	TEST	Input	Manufacturing test enable pin (connect to DGNG)
24	DGND	Power	Digital Ground

Table 5: mPLCC Parallel Pin Out

25	SDATA	I/O	Two-Wire Serial data I/O
26	LINE_VALID	Output	Line Valid
27	SADDR	Input	Two-Wire Serial address select. 0: 0x20, 1: 0x30
28	SCLK	Input	Two-Wire Serial clock input
29	VDD_IO	Power	I/O Power Supply
30	VDD	Power	Digital Power
31	RESET_BAR	Input	Asynchronous reset (active LOW). All settings are restored to factory default
32	OE_BAR	Input	Output enable (active LOW)
33	TRIGGER	Input	Exposure synchronization input
34	SHUTTER	Output	Control for external mechanical shutter. Can be left floating if not used.
35	RESERVED	Input	Reserved
36	AGND	Power	Analog Ground
37	VAA_2V8	Power	Analog Power
38	VAA_PIX	Power	Pixel Power
39	AGND	Power	Analog Ground
40	DGND	Power	Digital ground
41	VDD	Power	Digital Power
42	VDD_IO	Power	I/O Power Supply
43	DOUT0	Output	Data Output 0
44	DOUT1	Output	Data Output 1
45	DOUT2	Output	Data Output 2
46	DOUT3	Output	Data Output 3
47	DOUT4	Output	Data Output 4
48	DOUT5	Output	Data Output 5

Pixel Data Format

Pixel Array Structure

While the sensor's format is 1928 x1088, additional active columns and active rows are included for use when horizontal or vertical mirrored readout is enabled, to allow readout to start on the same pixel. The pixel adjustment is always performed for mono-chrome or color versions. The active area is surrounded with optically transparent dummy pixels to improve image uniformity within the active area. Not all dummy pixels or barrier pixels can be read out.

Figure 7: Pixel Array Description

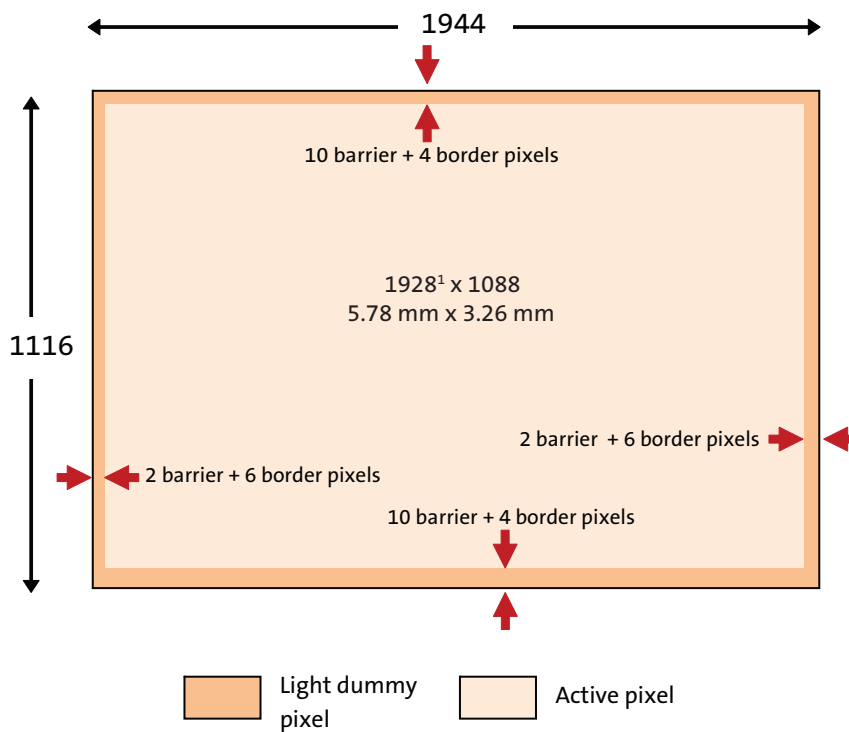

Figure 8: Pixel Color Pattern Detail (RGB) (Top Right Corner)

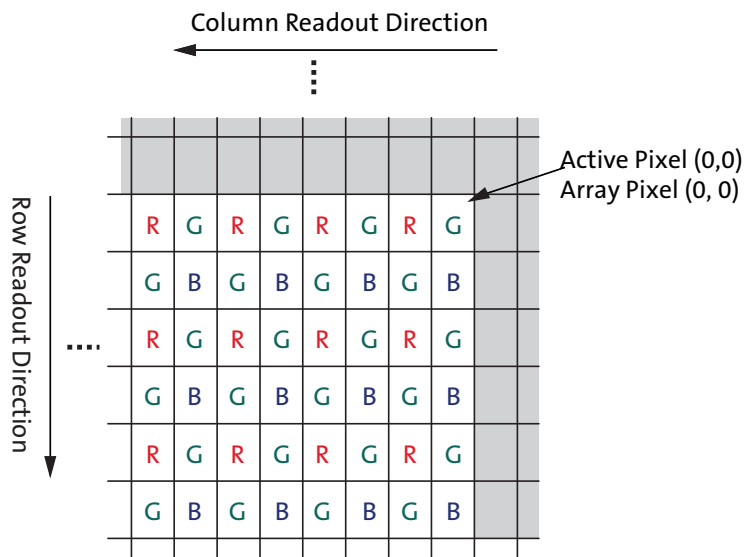
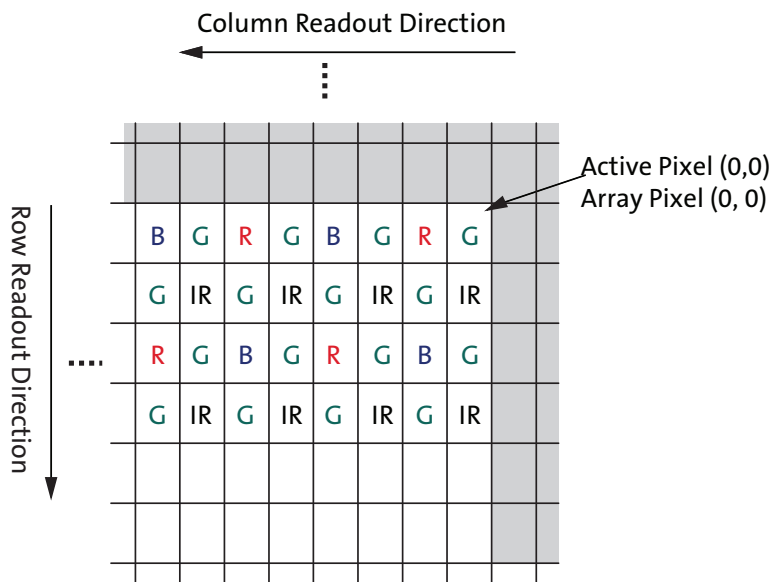

Figure 9: Pixel Color Pattern Detail RGB IR (Top Right Corner)



Default Readout Order

By convention, the sensor core pixel array is shown with pixel (0,0) in the top right corner (see Figure 8). This reflects the actual layout of the array on the die. Also, the first pixel data read out of the sensor in default condition is that of pixel (10, 14).

When the sensor is imaging, the active surface of the sensor faces the scene as shown in Figure 10. When the image is read out of the sensor, it is read one row at a time, with the rows and columns sequenced as shown in Figure 10.

Figure 10: Imaging a Scene

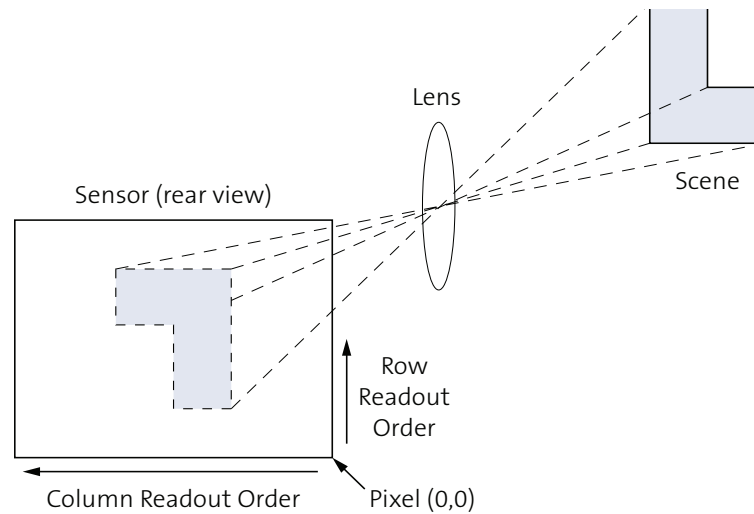

Features Overview

For a complete description, recommendations, and usage guidelines for product features, refer to the AR0237 Developer Guide.

3.0 μ m Dual Conversion Gain Pixel

To improve the low light performance and keep the high dynamic range, a large (3.0 μ m) dual conversion gain pixel is implemented for better image optimization. With a dual conversion gain pixel, the conversion gain of the pixel may be dynamically changed to better adapt the pixel response based on dynamic range of the scene.

HDR

By default, the sensor powers up in Linear Mode. One can change to HDR Mode. The HDR scheme used is multi-exposure HDR. This allows the sensor to handle up to 96 dB of dynamic range. In HDR mode, the sensor sequentially captures two exposures by maintaining two separate read and reset pointers that are interleaved within the rolling shutter readout. The exposure ratio may be set to 4x, 8x, 16x, or 32x. Sensor also provides flexibility to choose any exposure ratio by setting number of t2 exposure rows independent of the t1 exposure. The data will be output as line interleaved data as described in the T1/T2 Line Interleaved Mode section. There is also an option to output either T1 only or T2 only.

Resolution

The active array supports a maximum of 1928x1088 pixels to support 1080p resolution. Utilizing a 3.0 μ m pixel will result in an optical format of 1/2.7-inch (approximately 6.6mm diagonal).

Frame Rate

At full (1080p) resolution, the AR0237 is capable of running up to 60 fps in linear mode and 30 fps in line interleaved mode.

Image Acquisition Mode

The AR0237 supports two image acquisition modes:

- Electronic rolling shutter (ERS) mode

This is the normal mode of operation. When the AR0237 is streaming, it generates frames at a fixed rate, and each frame is integrated (exposed) using the ERS. When ERS mode is in use, timing and control logic within the sensor sequences through the rows of the array, resetting and then reading each row in turn. In the time interval between resetting a row and subsequently reading that row, the pixels in the row integrate incident light. The integration (exposure) time is controlled by varying the time between row reset and row readout. For each row in a frame, the time between row reset and row readout is the same, leading to a uniform integration time across the frame. When the integration time is changed (by using the two-wire serial interface to change register settings), the timing and control logic controls the transition from old to new integration

time in such a way that the stream of output frames from the AR0237 switches cleanly from the old integration time to the new while only generating frames with uniform integration. See “Changes to Integration Time” in the AR0237 Register Reference.

- Global reset mode.

This mode can be used to acquire a single image at the current resolution. In this mode, the end point of the pixel integration time is controlled by an external electromechanical shutter, and the AR0237 provides control signals to interface to that shutter. The benefit of using an external electromechanical shutter is that it eliminates the visual artifacts associated with ERS operation. Visual artifacts arise in ERS operation, particularly at low frame rates, because an ERS image effectively integrates each row of the pixel array at a different point in time.

Embedded Data and Statistics

The AR0237 has the capability to output image data and statistics embedded within the frame timing. There are two types of information embedded within the frame readout.

- Embedded Data:
If enabled, these are displayed on the two rows immediately before the first active pixel row is displayed.
- Embedded Statistics:
If enabled, these are displayed on the two rows immediately after the last active pixel row is displayed.

Multi-Camera Synchronization

The AR0237 supports advanced line synchronization controls for multi-camera (stereo) support.

Slave Mode

The slave mode feature of the AR0237 supports triggering the start of a frame readout from an input signal that is supplied from an external ASIC. The slave mode signal allows for precise control of frame rate and register change updates.

Context Switching and Register Updates

The user has the option of using the highly configurable context memory, or a simplified implementation in which only a subset of registers is available for switching. The AR0237 supports a highly configurable context switching RAM of size 256 x 16. Within this Context Memory, changes to any register may be stored. The register set for each context must be the same, but the number of contexts and registers per context are limited only by the size of the context memory.

Alternatively, the user may switch between two predefined register sets A and B by writing to a context switch change bit. When the context switch is configured to context A the sensor will reference the context A registers. If the context switch is changed from A to B during the readout of frame n, the sensor will then reference the context B coarse_integration_time registers in frame n+1 and all other context B registers at the beginning of reading frame n+2. The sensor will show the same behavior when changing from context B to context A. The registers listed in Table 6 are context-switchable:

Table 6: List of Configurable Registers for Context A and Context B

Context A	Context B
Register Description	Register Description
coarse_integration_time	coarse_integration_time_cb
line_length_pck	line_length_pck_cb
frame_length_lines	frame_length_lines_cb
row_bin	row_bin_cb
col_bin	col_bin_cb
fine_gain	fine_gain_cb
coarse_gain	coarse_gain_cb
coarse_integration_time2	coarse_integration_time2_cb
dcg_manual_set	dcg_manual_set_cb
dcg_manual_set_t1	dcg_manual_set_t1_cb
bypass_pix_comb	bypass_pix_cb
coarse_gain_t1	coarse_gain_t1_cb
fine_gain_t1	fine_gain_t1_cb
x_addr_start	x_addr_start_cb
y_addr_start	y_addr_start_cb
x_addr_end	x_addr_end_cb
y_addr_end	y_addr_end_cb
y_odd_inc	y_odd_inc_cb
x_odd_inc	x_odd_inc_cb
green1_gain	green1_gain_cb
blue_gain	blue_gain_cb
red_gain	red_gain_cb
green2_gain	green2_gain_cb
global_gain	global_gain_cb
operation_mode_ctrl	operation_mode_ctrl_cb
bypass_pix_comb	bypass_pix_comb_cb

Analog/Digital Gains

A programmable analog gain of 1.0x to 16x (linear and HDR) applied simultaneously to all color channels will be featured along with a digital gain of 1x to 16x that may be configured on a per color channel basis. Note that with the RGB IR sensor digital gain should only be applied to all color channels equally since with the 4x4 kernel the gains will not be applied to the proper color channel. Analog gain can be applied per exposure in line interleaved mode.

Skipping/Binning Modes

The AR0237 supports subsampling. Subsampling allows the sensor to read out a smaller set of active pixels by either skipping, binning, or summing pixels within the readout window. Horizontal binning is achieved in the digital readout. The sensor will sample the combined 2x adjacent pixels within the same color plane. Vertical row binning is applied in the pixel readout. Row binning can be configured as 2x rows within the same color plane. Pixel skipping can be configured up to 2x in both the x-direction and y-

direction. Skipping pixels in the x-direction will not reduce the row time. Skipping pixels in the y direction will reduce the number of rows from the sensor effectively reducing the frame time. Skipping will introduce image artifacts from aliasing.

The AR0237 supports row wise vertical binning. Row wise vertical summing is only supported in monochrome sensors.

Binning and summing is not supported with RGB IR sensors.

Clocking Options

The sensor contains a phase-locked loop (PLL) that is used for timing generation and control. The required VCO clock frequency is attained through the use of a pre-PLL clock divider followed by a multiplier. The PLL multiplier should be an even integer. If an odd integer (M) is programmed, the PLL will default to the lower (M-1) value to maintain an even multiplier value. The multiplier is followed by a set of dividers used to generate the output clocks required for the sensor array, the pixel analog and digital readout paths, and the output parallel and serial interfaces. Use of the PLL is required when using the HiSPi interface.

Temperature Sensor

The AR0237 sensor has a built-in PTAT-based temperature sensor, accessible through registers, that is capable of measuring die junction temperature. The value read out from the temperature sensor register is an ADC output value that needs to be converted downstream to a final temperature value in degrees Celsius. Since the PTAT device characteristic response is quite linear in the temperature range of operation required, a simple linear function can be used to convert the ADC output value to the final temperature in degrees Celsius.

A single reference point will be made available via register read as well as a slope for back-calculating the junction temperature value. An error of +/-5% or better over the full specified operating range of the sensor is to be expected.

Silicon / Firmware / Sequencer Revision Information

A revision register will be provided to read out (via I²C) silicon and sequencer/OTPM revision information. This will be helpful to distinguish among different lots of material if there are future OTPM or sequencer revisions.

Lens Shading Correction

The latest lens shading correction algorithm will be included for potential low Z height applications.

Compression

When the AR0237 is configured for linear mode operation, the sensor can optionally compress 12-bit data to 10-bit using A-law compression. The A-law compression is disabled by default.

Packaging

The AR0237 will be offered in a 10x10 80-iBGA package (parallel and HiSPi) and a 11.43x11.43 48 pin mPLCC (HiSSPi) package.

Parallel Interface

The parallel pixel data interface uses these output-only signals:

- FRAME_VALID
- LINE_VALID
- PIXCLK
- DOUT[11:0]

The parallel pixel data interface is disabled by default at power up and after reset. It can be enabled by programming R0x301A. When the parallel pixel data interface is in use, the serial data output signals can be left unconnected.

High Speed Serial Pixel (HiSPi) Interface

The HiSPi interface supports three protocols, Streaming-S, Streaming-SP, and Packetized SP. The streaming protocols conform to a standard video application where each line of active or intra-frame blanking provided by the sensor is transmitted at the same length. The Packetized SP protocol will transmit only the active data ignoring line-to-line and frame-to-frame blanking data.

The HiSPi interface building block is a unidirectional differential serial interface with four data and one double data rate (DDR) clock lanes. One clock for every four serial data lanes is provided for phase alignment across multiple lanes. The AR0237 supports serial data widths of 10 or 12 bits on one, two, or four lanes. The specification includes a DLL to compensate for differences in group delay for each data lane. The DLL is connected to the clock lane and each data lane, which acts as a control master for the output delay buffers. Once the DLL has gained phase lock, each lane can be delayed in 1/8 unit interval (UI) steps. This additional delay allows the user to increase the setup or hold time at the receiver circuits and can be used to compensate for skew introduced in PCB design. Delay compensation may be set for clock and/or data lines in the `hispi_timing` register R0x31C0. If the DLL timing adjustment is not required, the data and clock lane delay settings should be set to a default code of 0x0000 to reduce jitter, skew, and power dissipation.

Sensor Control Interface

The two-wire serial interface bus enables read/write access to control and status registers within the AR0237. The interface protocol uses a master/slave model in which a master controls one or more slave devices. The sensor acts as a slave device. The master generates a clock (SCLK) that is an input to the sensor and is used to synchronize transfers.

Data is transferred between the master and the slave on a bidirectional signal (SDATA). SDATA is pulled up to VDD_IO off-chip by a 1.5kΩ resistor. Either the slave or master device can drive SDATA LOW-the interface protocol determines which device is allowed to drive SDATA at any given time. The two-wire serial interface can run at 100 kHz or 400 kHz.

T1/T2 Line Interleaved Mode

The AR0237 outputs the T1 and T2 exposures separately, in a line interleaved format. The purpose of this is to enable off chip HDR linear combination and processing. See the AR0237 Developer Guide for more information.

Figure 11: Quantum Efficiency - RGB

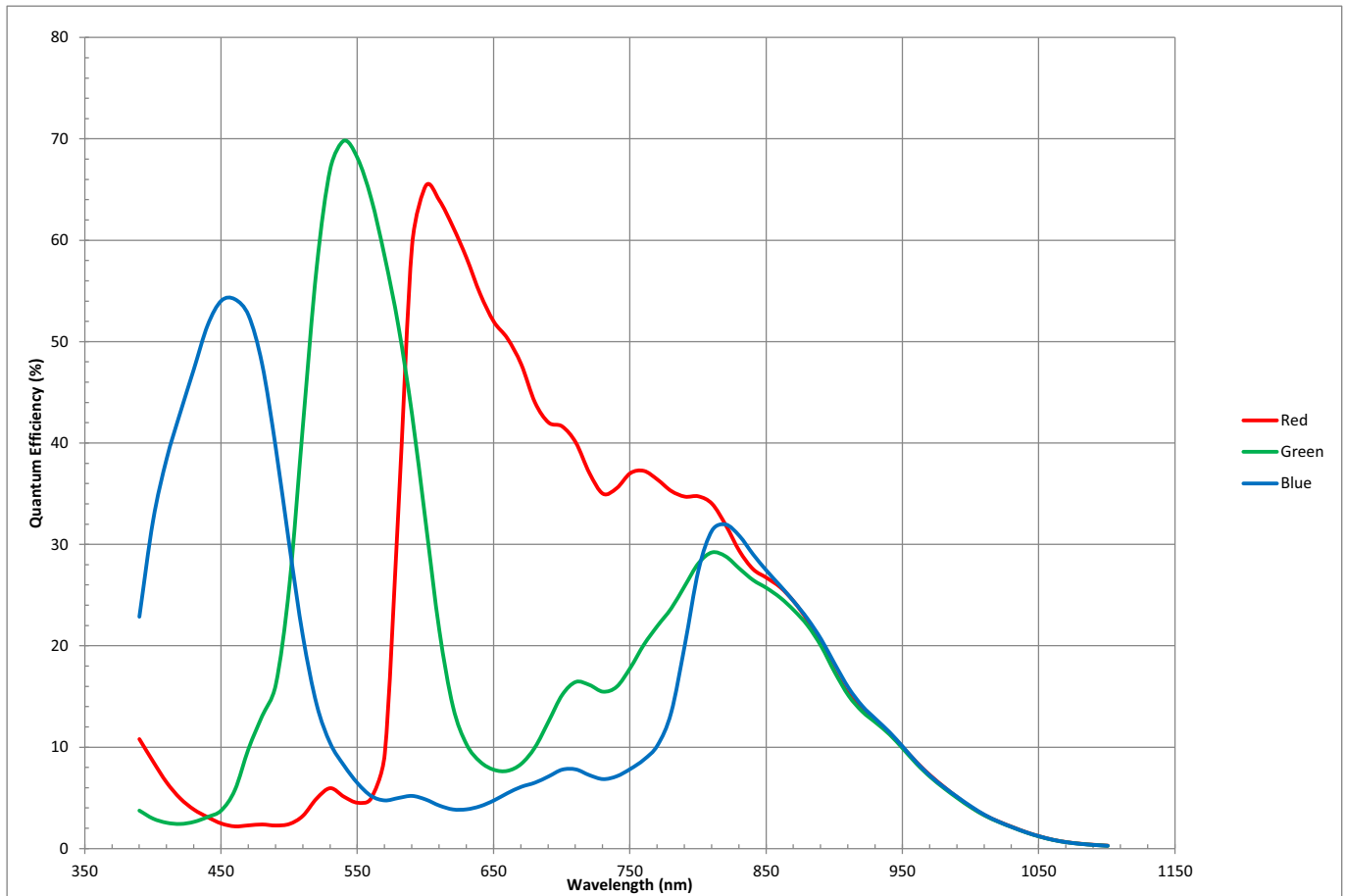
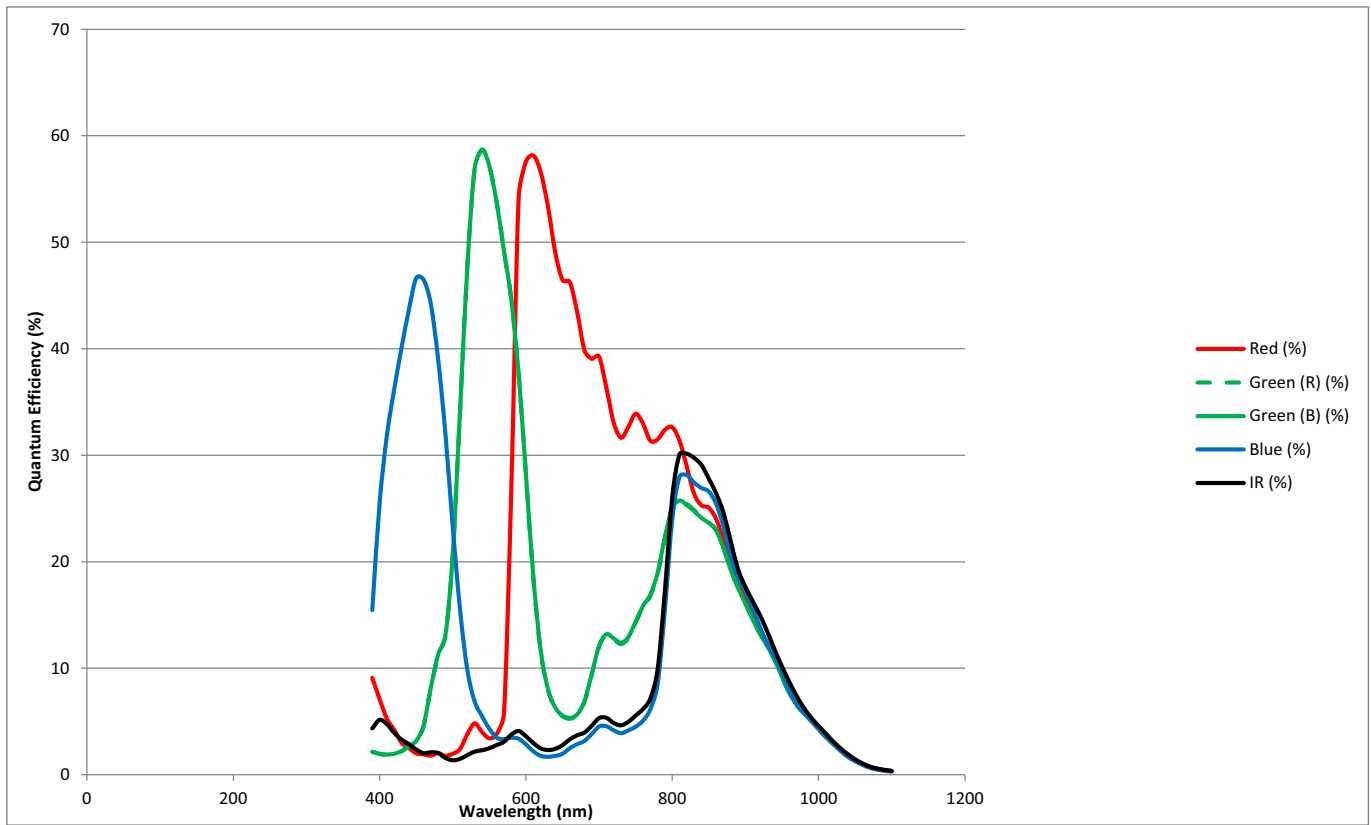

Figure 12: Quantum Efficiency - RGB - IR



Electrical Specifications

Unless otherwise stated, the following specifications apply under the following conditions: $V_{DD} = 1.8V - 0.10/+0.15$; $V_{DD_IO} = V_{DD_PLL} = V_{AA} = V_{AA_PIX} = 2.8V \pm 0.3V$; $V_{DD_SLVS} = 0.4V - 0.1/+0.2$; $T_A = -30^{\circ}C$ to $+85^{\circ}C$ - $40^{\circ}C$ to $+105^{\circ}C$; output load = 10pF; frequency = 74.25 MHz; HiSPi off.

Two-Wire Serial Register Interface

The electrical characteristics of the two-wire serial register interface (SCLK, SDATA) are shown in Figure 13 and Table 7.

Figure 13: Two-Wire Serial Bus Timing Parameters

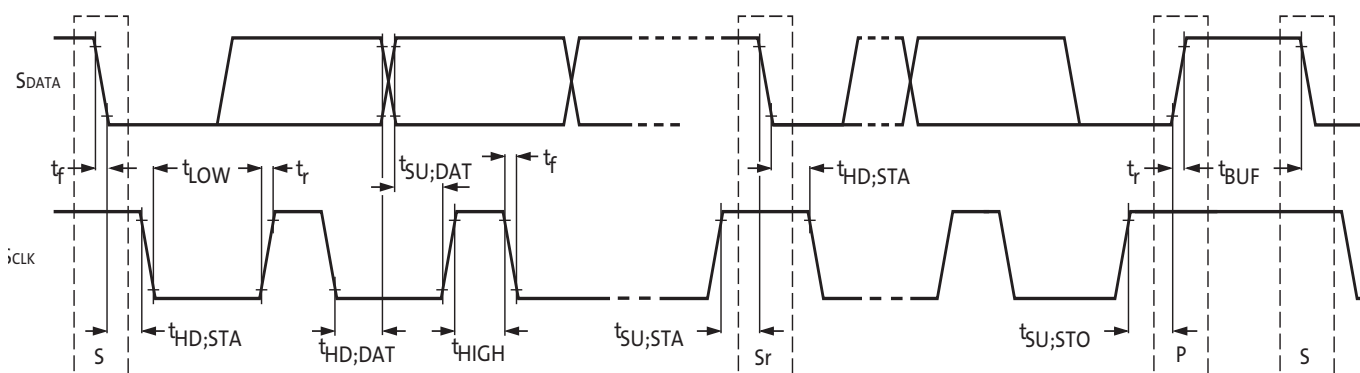

Note: Read sequence: For an 8-bit READ, read waveforms start after WRITE command and register address are issued.

Table 7: Two-Wire Serial Bus Characteristics

$f_{EXTCLK} = 27$ MHz; $V_{DD} = 1.8V$; $V_{DD_IO} = 2.8V$; $V_{AA} = 2.8V$; $V_{AA_PIX} = 2.8V$; $V_{DD_PLL} = 2.8V$; $T_A = 25^{\circ}C$

Parameter	Symbol	Standard Mode		Fast Mode		Unit
		Min	Max	Min	Max	
SCLK Clock Frequency	f_{SCLK}	0	100	0	400	KHz
Hold time (repeated) START condition. After this period, the first clock pulse is generated	$t_{HD;STA}$	4.0	-	0.6	-	μs
LOW period of the SCLK clock	t_{LOW}	4.7	-	1.3	-	μs
HIGH period of the SCLK clock	t_{HIGH}	4.0	-	0.6	-	μs
Set-up time for a repeated START condition	$t_{SU;STA}$	4.7	-	0.6	-	μs
Data hold time	$t_{HD;DAT}$	0 ⁴	3.45 ⁵	0 ⁶	0.9 ⁵	μs
Data set-up time	$t_{SU;DAT}$	250	-	100 ⁶	-	ns
Rise time of both SDATA and SCLK signals	t_r	-	1000	$20 + 0.1Cb^7$	300	ns
Fall time of both SDATA and SCLK signals	t_f	-	300	$20 + 0.1Cb^7$	300	ns
Set-up time for STOP condition	$t_{SU;STO}$	4.0	-	0.6	-	μs
Bus free time between a STOP and START condition	t_{BUF}	4.7	-	1.3	-	μs
Capacitive load for each bus line	C_b	-	400	-	400	pF

Table 7: Two-Wire Serial Bus Characteristics (continued)

$f_{EXTCLK} = 27 \text{ MHz}$; $V_{DD} = 1.8\text{V}$; $V_{DD_IO} = 2.8\text{V}$; $V_{AA} = 2.8\text{V}$; $V_{AA_PIX} = 2.8\text{V}$; $V_{DD_PLL} = 2.8\text{V}$; $T_A = 25^\circ\text{C}$

Parameter	Symbol	Standard Mode		Fast Mode		Unit
		Min	Max	Min	Max	
Serial interface input pin capacitance	CIN_SI	-	3.3	-	3.3	pF
SDATA max load capacitance	CLOAD_SD	-	30	-	30	pF
SDATA pull-up resistor	RSD	1.5	4.7	1.5	4.7	K Ω

- Notes:
1. This table is based on I²C standard (v2.1 January 2000). Philips Semiconductor.
 2. Two-wire control is I²C-compatible.
 3. All values referred to $V_{IHmin} = 0.9 V_{DD}$ and $V_{ILmax} = 0.1V_{DD}$ levels. Sensor EXCLK = 27 MHz.
 4. A device must internally provide a hold time of at least 300 ns for the SDATA signal to bridge the undefined region of the falling edge of SCLK.
 5. The maximum $t_{HD;DAT}$ has only to be met if the device does not stretch the LOW period (t_{LOW}) of the SCLK signal.
 6. A Fast-mode I²C-bus device can be used in a Standard-mode I²C-bus system, but the requirement $t_{SU;DAT} \geq 250 \text{ ns}$ must then be met. This will automatically be the case if the device does not stretch the LOW period of the SCLK signal. If such a device does stretch the LOW period of the SCLK signal, it must output the next data bit to the SDATA line $t_r \text{ max} + t_{SU;DAT} = 1000 + 250 = 1250 \text{ ns}$ (according to the Standard-mode I²C-bus specification) before the SCLK line is released.
 7. C_b = total capacitance of one bus line in pF.

I/O Timing

By default, the AR0237 launches pixel data, FV, and LV with the falling edge of PIXCLK. The expectation is that the user captures DOUT[11:0], FV, and LV using the rising edge of PIXCLK.

See Figure 14 below and Table 8 on page 28 for I/O timing (AC) characteristics.

Figure 14: I/O Timing Diagram

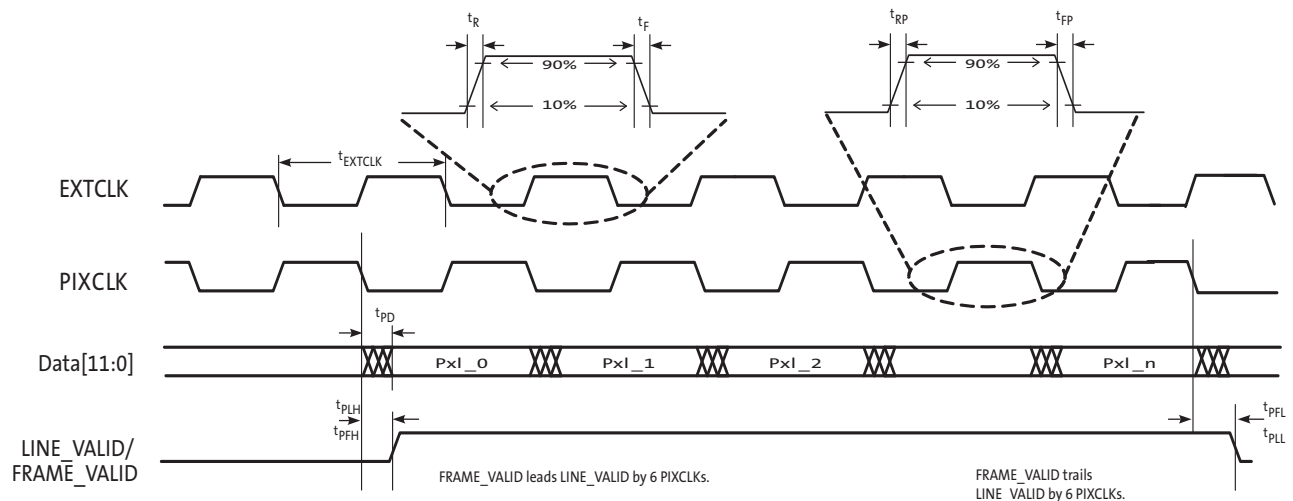

Table 8: I/O Timing Characteristics

Symbol	Definition	Condition	Min	Typ	Max	Unit
$f_{EXTCLK1s}$	Input clock frequency		6	–	48	MHz
$t_{EXTCLK1}$	Input clock period		20.8	–	166	ns
t_R	Input clock rise time		–	3	–	ns
t_F	Input clock fall time		–	3	–	ns
t_{RP}	Pixclk rise time		2	3.5	5	ns
t_{FP}	Pixclk fall time		2	3.5	5	ns
	Clock duty cycle		45	50	55	%
t_{CP}	EXTCLK to PIXCLK propagation delay	Nominal voltages, PLL Disabled	10	14	18	ns
f_{PIXCLK}	PIXCLK frequency	Default, Nominal Voltages	6	–	74.25	MHz
t_{PD}	PIXCLK to data valid	Default, Nominal Voltages	–	3	–	ns
t_{PFH}	PIXCLK to FV HIGH	Default, Nominal Voltages	–	3	–	ns
t_{PLH}	PIXCLK to LV HIGH	Default, Nominal Voltages	–	3	–	ns
t_{PFL}	PIXCLK to FV LOW	Default, Nominal Voltages	–	3	–	ns
t_{PLL}	PIXCLK to LV LOW	Default, Nominal Voltages	–	3	–	ns
CLOAD	Output load capacitance		–	<10	–	pF
CIN	Input pin capacitance		–	2.5	–	pF

Note: I/O timing characteristics are measured under the following conditions:
 - Temperature is 25°C ambient
 - 10 pF load
 - 1.8V I/O supply voltage

DC Electrical Characteristics

The DC electrical characteristics are shown in the tables below.

Table 9: DC Electrical Characteristics

Symbol	Definition	Condition	Min	Typ	Max	Unit
VDD	Core digital voltage		1.7	1.8	1.95	V
VDD_IO	I/O digital voltage		1.7/2.5	1.8/2.8	1.9/3.1	V
VAA	Analog voltage		2.5	2.8	3.1	V
VAA_PIX	Pixel supply voltage		2.5	2.8	3.1	V
VDD_PLL	PLL supply voltage		2.5	2.8	3.1	V
VDD_SLVS	HiSPi supply voltage		0.3	0.4	0.6	V
VIH	Input HIGH voltage		$V_{DD_IO} \cdot 0.7$	–	–	V
VIL	Input LOW voltage		–	–	$V_{DD_IO} \cdot 0.3$	V
IIN	Input leakage current	No pull-up resistor; $V_{IN} = V_{DD_IO}$ or DGND	20	–	–	μA
VOH	Output HIGH voltage		$V_{DD_IO} - 0.3$	–	–	V
VOL	Output LOW voltage		–	–	0.4	V
IOH	Output HIGH current	At specified VOH	-22	–	–	mA
IOL	Output LOW current	At specified VOL	–	–	22	mA

Caution Stresses greater than those listed in Table 10 may cause permanent damage to the device. This is a stress rating only, and functional operation of the device at these or any other conditions above those indicated in the operational sections of this specification is not implied.

Table 10: Absolute Maximum Ratings

Symbol	Definition	Condition	Min	Max	Unit
VDD_MAX	Core digital voltage		-0.3	2.4	V
VDD_IO_MAX	I/O digital voltage		-0.3	4	V
VAA_MAX	Analog voltage		-0.3	4	V
VAA_PIX	Pixel supply voltage		-0.3	4	V
VDD_PLL	PLL supply voltage		-0.3	4	V
VDD_SLVS_MAX	HiSPi I/O digital voltage		-0.3	2.4	V
t _{ST}	Storage temperature		-40	85	°C

Note: Exposure to absolute maximum rating conditions for extended periods may affect reliability.

Table 11: 1080p30 Linear 74 MHz Parallel 2.8V

Definition	Condition	Symbol	Voltage	Min	Typ	Max	Unit
Digital operating current	Streaming 1080p30	IDD	1.8	20	34	50	mA
I/O digital operating current	Streaming 1080p30	IDD_IO	2.8	15	28	50	mA
Analog operating current	Streaming 1080p30	IAA	2.8	15	26	50	mA
Pixel supply current	Streaming 1080p30	IAA_PIX	2.8	1	3	7	mA
PLL supply current	Streaming 1080p30	IDD_PLL	2.8	5.5	6.4	7	mA
			Power	138.2	238.72	409.2	mW

Note: Operating currents are measured in mA at the following conditions:
 - VAA = VAA_PIX = VDD_PLL = VDD_IO = 2.8 V
 - VDD = 1.8 V
 - PLL Enabled and PIXCLK = 74.25 MHz
 - Low power mode enabled
 - TA = 25°C

Table 12: 1080p30 Linear 74 MHz Parallel 1.8V

Definition	Condition	Symbol	Voltage	Min	Typ	Max	Unit
Digital operating current	Streaming 1080p30	IDD	1.8	20	34	50	mA
I/O digital operating current	Streaming 1080p30	IDD_IO	1.8	10	14	30	mA
Analog operating current	Streaming 1080p30	IAA	2.8	15	26	50	mA
Pixel supply current	Streaming 1080p30	IAA_PIX	2.8	1	3	7	mA
PLL supply current	Streaming 1080p30	IDD_PLL	2.8	5.5	6.4	7	mA
			Power	114.2	185.52	323.2	mW

Note: Operating currents are measured in mA at the following conditions:
 - VAA = VAA_PIX = VDD_PLL = 2.8 V
 - VDD = VDD_IO = 1.8 V
 - PLL Enabled and PIXCLK = 74.25 MHz
 - Low power mode enabled
 - TA = 25°C Dark Image, 8x Analog Gain, HCG, 20ms integration time

Table 13: 1080p30 Linear 74 MHz HiSPi SLVS

Definition	Condition	Symbol	Voltage	Min	Typ	Max	Unit
Digital Operating Current	Streaming 1080p30	IDD	1.8	25	44	65	mA
Analog Operating Current	Streaming 1080p30	IAA	2.8	15	26	50	mA
Pixel Supply Current	Streaming 1080p30	IAA_PIX	2.8	1	3	7	mA
PLL Supply Current	Streaming 1080p30	IDD_PLL	2.8	6	7.5	8.5	mA
SLVS Supply Current	Streaming 1080p30	IDD_SLVS	0.4	6	9.5	14	mA
			Power	109	185.2	306	mW

Note: Operating currents are measured in mA at the following conditions:
 - VAA = VAA_PIX = VDD_PLL = 2.8 V
 - VDD = VDD_IO = 1.8 V
 - VDD_SLVS = 0.4V
 - PLL Enabled and PIXCLK = 74.25 MHz
 - 4-lane HiSPi mode
 - Low power mode enabled
 - TA = 25°C Dark Image, 8x Analog Gain, HCG, 20ms integration time

Table 14: 1080p30 Linear 74 MHz HiSPi HiVcm

Definition	Condition	Symbol	Voltage	Min	Typ	Max	Unit
Digital Operating Current	Streaming 1080p30	IDD	1.8	25	44	65	mA
Analog Operating Current	Streaming 1080p30	IAA	2.8	15	26	50	mA
Pixel Supply Current	Streaming 1080p30	IAA_PIX	2.8	1	3	7	mA
PLL Supply Current	Streaming 1080p30	IDD_PLL	2.8	6	7.5	8.5	mA
SLVS Supply Current	Streaming 1080p30	IDD_SLVS	1.8	12	20	35	mA
			Power	128.2	217.4	363.4	mW

Note: Operating currents are measured in mA at the following conditions:
 - VAA = VAA_PIX = VDD_PLL = 2.8 V
 - VDD = VDD_IO = VDD_SLVS = 1.8 V
 - PLL Enabled and PIXCLK = 74.25 MHz
 - 4-lane HiSPi mode
 - Low power mode enabled
 - TA = 25°C Dark Image, 8x Analog Gain, HCG, 20ms integration time

Table 15: 1080p30 74 MHz Line Interleaved SLVS

Definition	Condition	Symbol	Voltage	Min	Typ	Max	Unit
Digital Operating Current	Streaming 1080p30	IDD	1.8	50	88	130	mA
Analog Operating Current	Streaming 1080p30	IAA	2.8	20	36	60	mA
Pixel Supply Current	Streaming 1080p30	IAA_PIX	2.8	1	4	8	mA
PLL Supply Current	Streaming 1080p30	IDD_PLL	2.8	7	8.5	9.5	mA
SLVS Supply Current	Streaming 1080p30	IDD_SLVS	0.4	6	9.5	14	mA
			Power	170.8	298	442.6	mW

Note: Operating currents are measured in mA at the following conditions:
 - VAA = VAA_PIX = VDD_PLL = 2.8 V
 - VDD = VDD_IO = 1.8 V
 - VDD_SLVS = 0.4V
 - PLL Enabled and PIXCLK = 74.25 MHz
 - 4-lane HiSPi mode
 - TA = 25°C Dark Image, 8x Analog Gain, HCG, 20ms integration time

Table 16: 1080p30 74 MHz Line Interleaved HiVcm

Definition	Condition	Symbol	Voltage	Min	Typ	Max	Unit
Digital Operating Current	Streaming 1080p30	IDD	1.8	50	88	130	mA
Analog Operating Current	Streaming 1080p30	IAA	2.8	20	36	60	mA
Pixel Supply Current	Streaming 1080p30	IAA_PIX	2.8	1	4	8	mA
PLL Supply Current	Streaming 1080p30	IDD_PLL	2.8	7	8.5	9.5	mA
SLVS Supply Current	Streaming 1080p30	IDD_SLVS	1.8	12	20	35	mA
			Power	190	330.2	500	mW

Note: Operating currents are measured in mA at the following conditions:
 - VAA = VAA_PIX = VDD_PLL = 2.8 V
 - VDD = VDD_IO = 1.8 V
 - VDD_SLVS = 1.8 V
 - PLL Enabled and PIXCLK = 74.25 MHz
 - 4-lane HiSPi mode
 - TA = 25°C Dark Image, 8x Analog Gain, HCG, 20ms integration time

HiSPi Electrical Specifications

The ON Semiconductor AR0237 sensor supports both SLVS and HiVCM HiSPi modes. Refer to the High-Speed Serial Pixel (HiSPi) Interface Physical Layer Specification v2.00.00 for electrical definitions, specifications, and timing information. The VDD_SLVS supply in this datasheet corresponds to VDD_TX in the HiSPi Physical Layer Specification. Similarly, VDD is equivalent to VDD_HiSPi as referenced in the specification. The DLL as implemented on AR0237 is limited in the number of available delay steps and differs from the HiSPi specification as described in this section.

Table 17: Channel Skew

Measurement Conditions: VDD_HiSPi = 1.8V; VDD_HiSPi_TX = 0.4V; Data Rate = 480 Mbps; DLL set to 0

Data Lane Skew in Reference to Clock	tCHSKEW1PHY	-150	ps
--------------------------------------	-------------	------	----

Power-On Reset and Standby Timing

Power-Up Sequence

The recommended power-up sequence for the AR0237 is shown in Figure 15. The available power supplies (VDD_IO, VDD, VDD_SLVS, VDD_PLL, VAA, VAA_PIX) must have the separation specified below.

1. Turn on VDD_PLL power supply.
2. After 100µs, turn on VAA and VAA_PIX power supply.
3. After 100µs, turn on VDD_IO power supply.
4. After 100µs, turn on VDD power supply.
5. After 100µs, turn on VDD_SLVS power supply.
6. After the last power supply is stable, enable EXTCLK.
7. Assert RESET_BAR for at least 1ms. The parallel interface will be tri-stated during this time.
8. Wait 150000 EXTCLKs (for internal initialization into software standby).
9. Configure PLL, output, and image settings to desired values.
10. Wait 1ms for the PLL to lock.
11. Set streaming mode (R0x301a[2] = 1).

Figure 15: Power Up

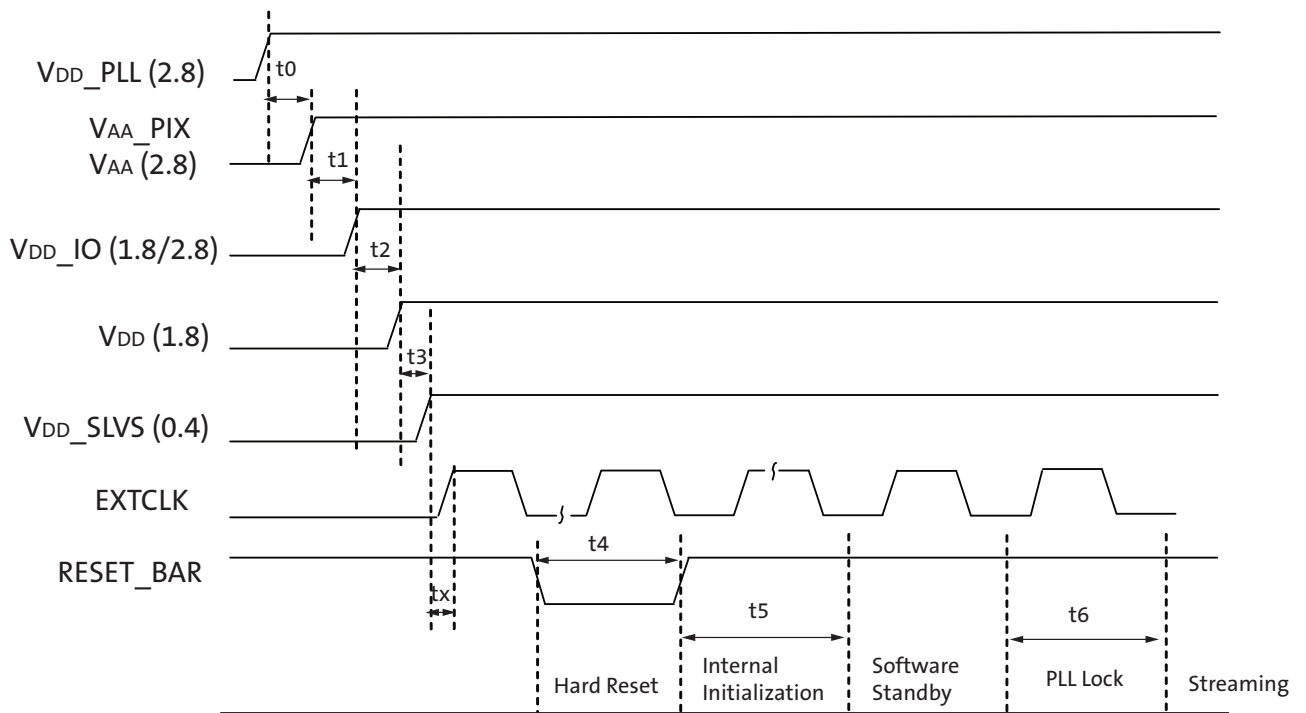

**Table 18: Power-Up Sequence**

Definition	Symbol	Minimum	Typical	Maximum	Unit
VDD_PLL to VAA/VAA_PIX ³	t0	0	100	–	μs
VAA/VAA_PIX to VDD_IO	t1	0	100	–	μs
VDD_IO to VDD	t2	0	100	–	μs
VDD to VDD_SLVS	t3	0	100	–	μs
Xtal settle time	tx	–	30 ¹	–	ms
Hard Reset	t4	1 ²	–	–	ms
Internal Initialization	t5	150000	–	–	EXTCLKs
PLL Lock Time	t6	1	–	–	ms

- Notes:
1. Xtal settling time is component-dependent, usually taking about 10 – 100 ms.
 2. Hard reset time is the minimum time required after power rails are settled. In a circuit where Hard reset is held down by RC circuit, then the RC time must include the all power rail settle time and Xtal settle time.
 3. It is critical that VDD_PLL is not powered up after the other power supplies. It must be powered before or at least at the same time as the others. If the case happens that VDD_PLL is powered after other supplies then sensor may have functionality issues and will experience high current draw on this supply.

Power-Down Sequence

The recommended power-down sequence for the AR0237 is shown in Figure 16. The available power supplies (VDD_IO, VDD, VDD_SLVS, VDD_PLL, VAA, VAA_PIX) must have the separation specified below.

1. Disable streaming if output is active by setting standby R0x301a[2] = 0
2. The soft standby state is reached after the current row or frame, depending on configuration, has ended.
3. Turn off VDD_SLVS.
4. Turn off VDD.
5. Turn off VDD_IO.
6. Turn off VAA/VAA_PIX.
7. Turn off VDD_PLL.

Figure 16: Power Down

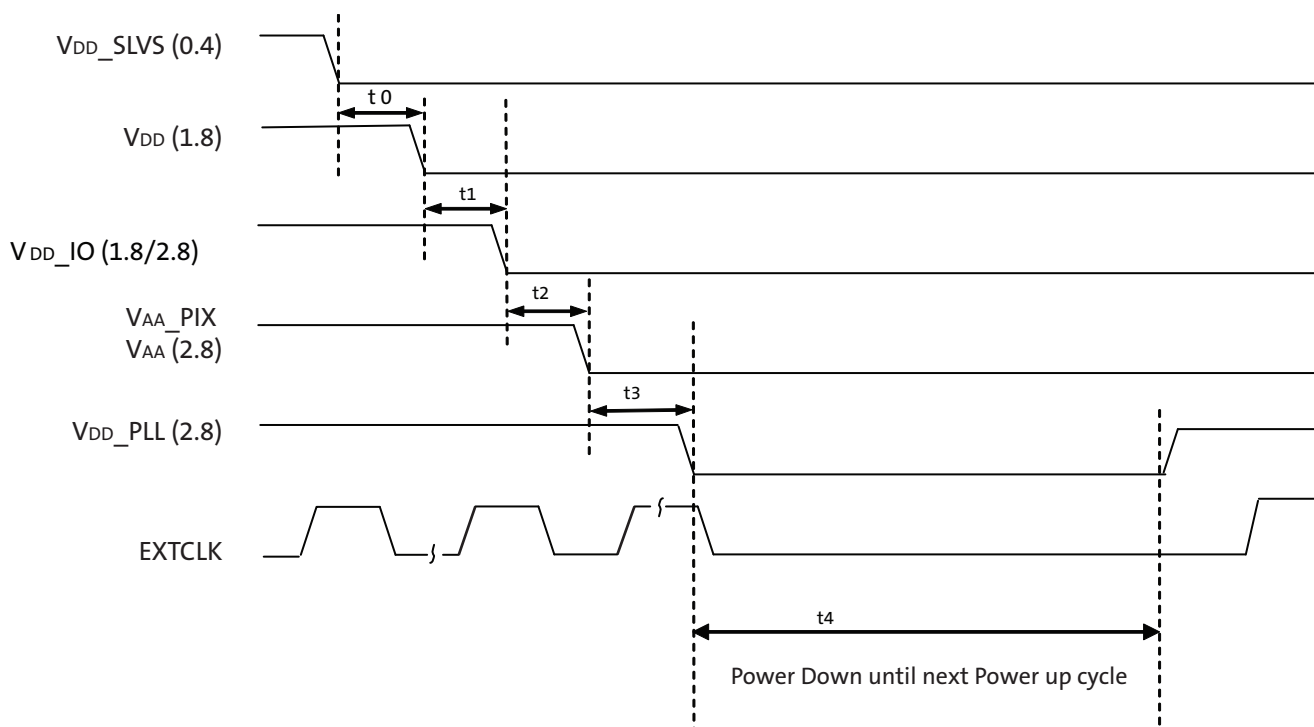

Table 19: Power-Down Sequence

Definition	Symbol	Minimum	Typical	Maximum	Unit
VDD_SLVS to VDD	t0	0	–	–	μs
VDD to VDD_IO	t1	0	–	–	μs
VDD_IO to VAA/VAA_PIX	t2	0	–	–	μs
VAA/VAA_PIX to VDD_PLL	t3	0	–	–	μs
Power Down until Next Power Up Time	t4	100	–	–	ms

t4 is required between power down and next power up time; all decoupling caps from regulators must be completely discharged.

Package Diagrams

Figure 17: PLCC 48 11.43 x 11.43 Package Diagram (Case 776AQ)

PLCC48 11.43x11.43
CASE 776AQ
ISSUE A

DATE 20 NOV 2015

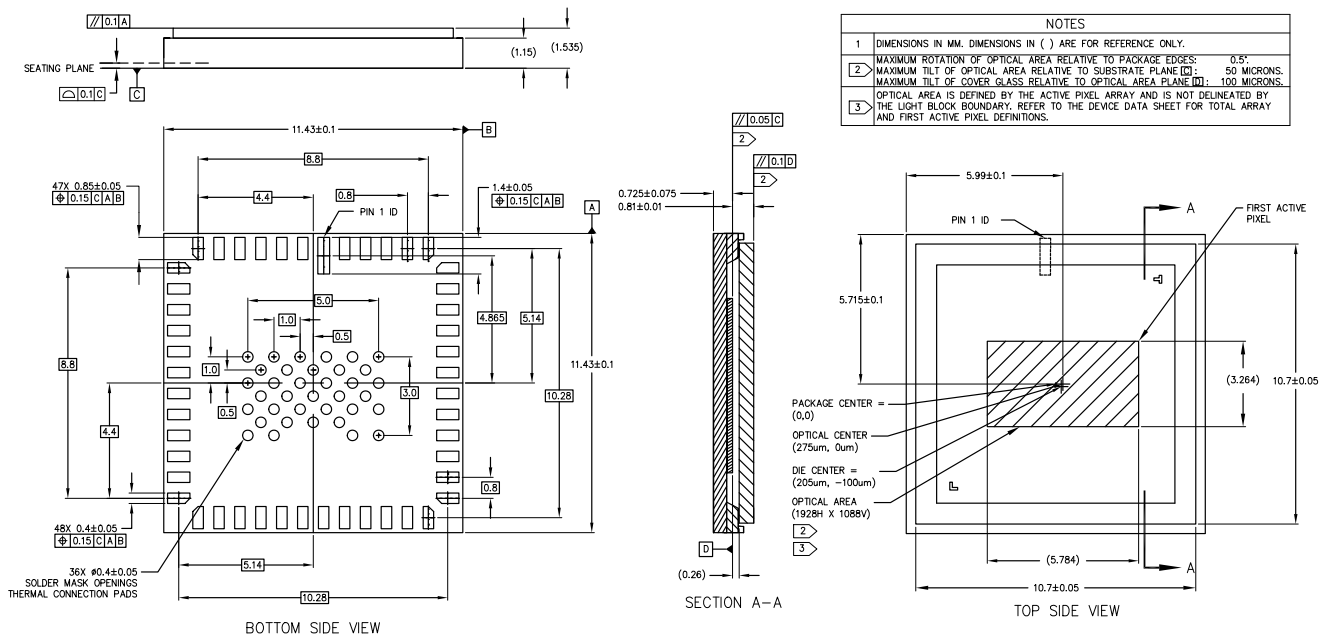
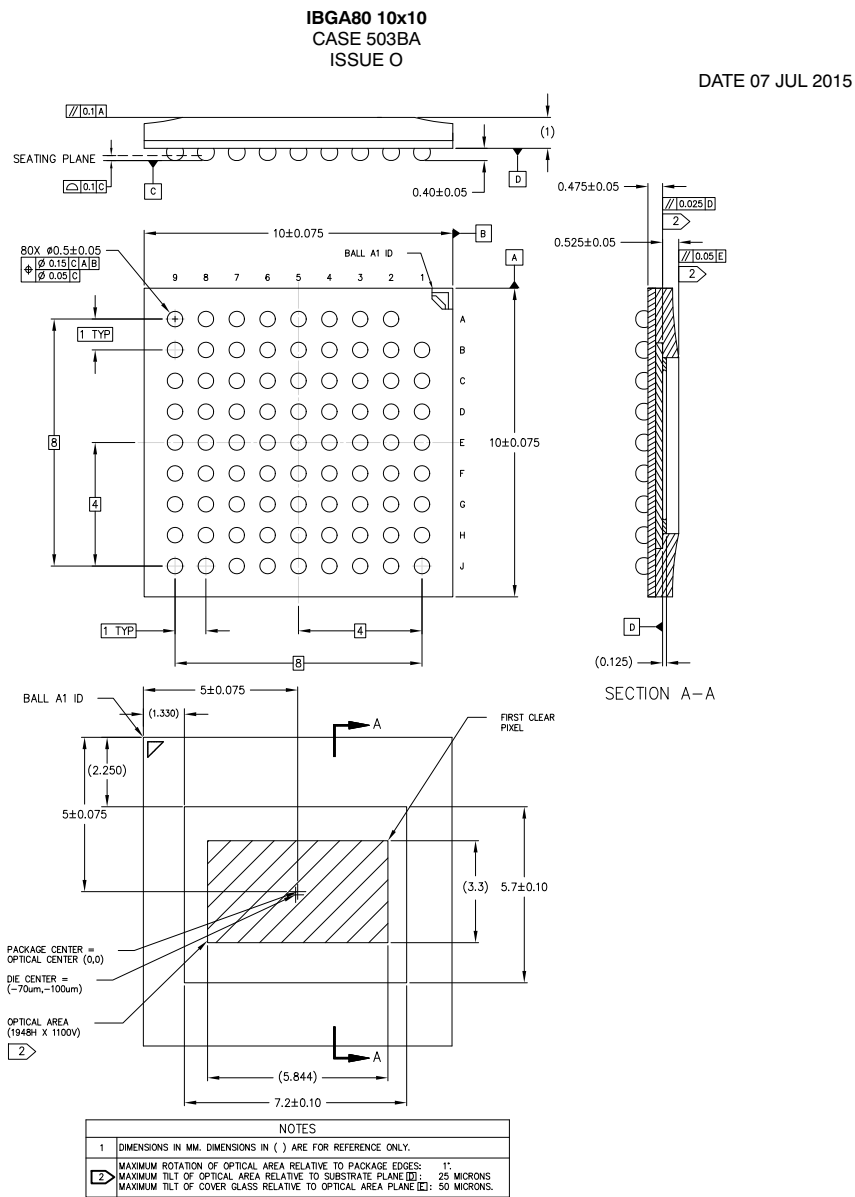

Figure 18: 80iBGA 10x10 Package Diagram (Case 503BA)



ON Semiconductor and the ON Logo are trademarks of Semiconductor Components Industries, LLC dba ON Semiconductor or its subsidiaries in the United States and/or other countries. ON Semiconductor owns the rights to a number of patents, trademarks, copyrights, trade secrets, and other intellectual property. A listing of ON Semiconductor's product/patent coverage may be accessed at www.onsemi.com/site/pdf/Patent-Marking.pdf. ON Semiconductor reserves the right to make changes without further notice to any products herein. ON Semiconductor makes no warranty, representation or guarantee regarding the suitability of its products for any particular purpose, nor does ON Semiconductor assume any liability arising out of the application or use of any product or circuit, and specifically disclaims any and all liability, including without limitation special, consequential or incidental damages. Buyer is responsible for its products and applications using ON Semiconductor products, including compliance with all laws, regulations and safety requirements or standards, regardless of any support or applications information provided by ON Semiconductor. "Typical" parameters which may be provided in ON Semiconductor data sheets and/or specifications can and do vary in different applications and actual performance may vary over time. All operating parameters, including "Typicals" must be validated for each customer application by customer's technical experts. ON Semiconductor does not convey any license under its patent rights nor the rights of others. ON Semiconductor products are not designed, intended, or authorized for use as a critical component in life support systems or any FDA Class 3 medical devices or medical devices with a same or similar classification in a foreign jurisdiction or any devices intended for implantation in the human body. Should Buyer purchase or use ON Semiconductor products for any such unintended or unauthorized application, Buyer shall indemnify and hold ON Semiconductor and its officers, employees, subsidiaries, affiliates, and distributors harmless against all claims, costs, damages, and expenses, and reasonable attorney fees arising out of, directly or indirectly, any claim of personal injury or death associated with such unintended or unauthorized use, even if such claim alleges that ON Semiconductor was negligent regarding the design or manufacture of the part. ON Semiconductor is an Equal Opportunity/Affirmative Action Employer. This literature is subject to all applicable copyright laws and is not for resale in any manner.