

ALM-32220

1.7 GHz – 2.7 GHz
2 Watt High Linearity Amplifier



Data Sheet

Description

Avago Technologies' ALM-32220 is a high linearity 2 Watt PA with good OIP3 performance and exceptionally good PAE at 1dB gain compression point, achieved through the use of Avago Technologies' proprietary 0.25 μm GaAs Enhancement-mode pHEMT process.

All matching components are fully integrated within the module. This makes the ALM-32220 extremely easy to use. The adjustable temperature-compensated internal bias circuit allows the device to be operated at either class A or class AB operation. The ALM-32220 is housed inside a miniature $7.0 \times 10.0 \times 1.1 \text{ mm}^3$ 20-lead multiple-chips-on-board (MCOB) module package.

Component Image

$7.0 \times 10.0 \times 1.1 \text{ mm}^3$ 20-Lead MCOB Package

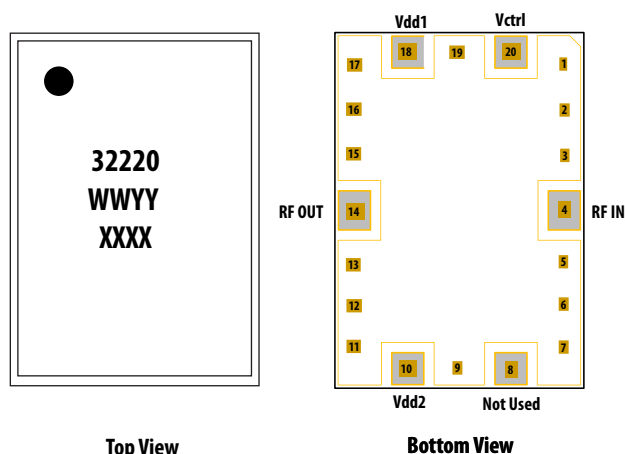

Notes:
Package marking provides orientation and identification
"32220" = Device Part Number
"WWYY" = Work week and year of manufacture
"XXXX" = Last 4 digit of lot number

Features

- Fully matched, input and output
- High linearity and P1dB
- Unconditionally stable across load condition
- Built-in adjustable temperature compensated internal bias circuitry
- GaAs E-pHEMT Technology^[1]
- 5V supply
- Excellent uniformity in product specifications
- Tape-and-Reel packaging option available
- MSL-3 and Lead-free
- High MTTF for base station application

Specifications

2GHz; 5V, 800mA (typical)

- 14.8 dB Gain
- 50.0 dBm Output IP3
- 34.4 dBm Output Power at 1dB gain compression
- 47.5% PAE at P1dB
- 3.5dB Noise Figure

Applications

- Class A driver amplifier for GSM/PCS/W-CDMA/WiMAX Base Stations.
- General purpose gain block.

Note:

1. Enhancement mode technology employs positive gate voltage, thereby eliminating the need of negative gate voltage associated with conventional depletion mode devices.
2. Good RF practice requires all unused pins to be earthed.



Attention: Observe precautions for handling electrostatic sensitive devices.

ESD Machine Model = 200 V
ESD Human Body Model = 1000 V
Refer to Avago Application Note A004R:
Electrostatic Discharge, Damage and Control.

Absolute Maximum Rating ^[1] T_A=25°C

Symbol	Parameter	Units	Absolute Max.
V _{dd,max}	Device Voltage, RF output to ground	V	5.5
I _{ds,max}	Device Drain Current	mA	1500
V _{ctrl,max}	Control Voltage	V	5.5
P _{in,max}	CW RF Input Power	dBm	28
P _{diss}	Total Power Dissipation ^[3]	W	8.25
T _{j,max}	Junction Temperature	°C	150
T _{STG}	Storage Temperature	°C	-65 to 150

Thermal Resistance ^[2] $\theta_{jc} = 14 \text{ }^\circ\text{C/W}$
(V_{dd}=5, I_{ds}=800mA, T_c=85°C)

Notes:

1. Operation of this device in excess of any of these limits may cause permanent damage.
2. Thermal resistance measured using Infra-Red measurement technique.
3. This is limited by maximum V_{dd} and I_{ds}. Derate 71.4mW/°C for T_c> 34.5 °C.

Product Consistency Distribution Charts^[4]

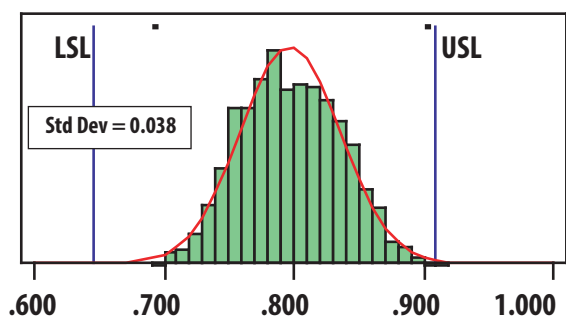

Figure 1. I_{ds}; LSL = 640mA, nominal = 800mA, USL = 910mA

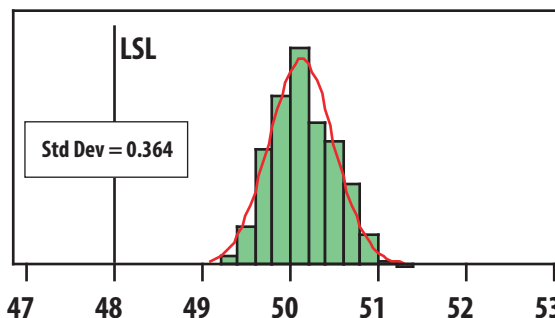

Figure 2. OIP3; LSL = 48dBm, nominal = 50dBm

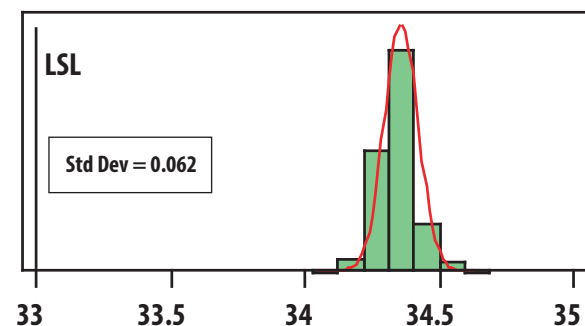

Figure 3. P1dB; LSL = 33dBm, nominal = 34.4dBm

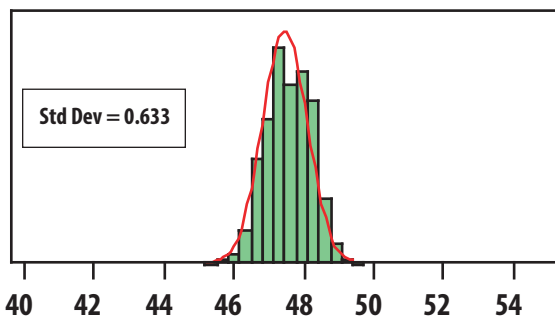

Figure 4. PAE at P1dB; nominal = 47.5%

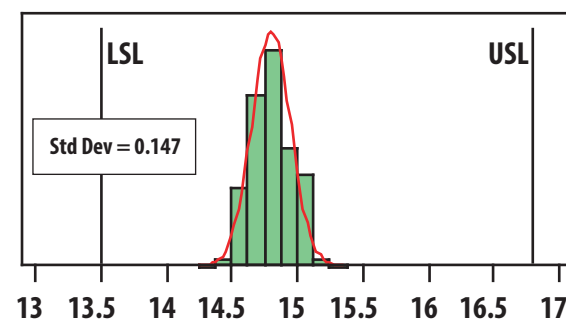

Figure 5. Gain; LSL=13.5dB, Nominal = 14.8dB, USL=16.8dB

Note:

4. Distribution data sample size is 500 samples taken from 3 different wafer lots. T_A = 25°C, V_{dd} = 5V, V_{ctrl} = 5V, RF performance at 2GHz unless otherwise specified. Future wafers allocated to this product may have nominal values anywhere between the upper and lower limits.
5. Measurements are made on a production test board. Input trace losses have not been de-embedded from actual measurements.

Electrical Specifications [1]

T_A = 25 °C, V_{dd} = 5V, V_{ctrl} = 5V, RF performance at 2GHz, measured on demo board (see Figure 7) unless otherwise specified.

Symbol	Parameter and Test Condition	Units	Min.	Typ.	Max.
I _{ds}	Quiescent current	mA	640	800	910
I _{ctrl}	V _{ctrl} current	mA	-	11	-
Gain	Gain	dB	13.5	14.8	16.8
OIP3 [2]	Output Third Order Intercept Point	dBm	48	50	-
OP1dB	Output Power at 1dB Gain Compression	dBm	33.0	34.4	-
PAE	Power Added Efficiency	%	-	47.5	-
NF	Noise Figure (Typ.V _{ctrl} =5.0V)	dB	-	3.5	-
S11	Input Return Loss, 50Ω source	dB	-	-9.0	-
S22	Output Return Loss, 50Ω load	dB	-	-9.0	-
S12	Reverse Isolation	dB	-	-30	-

Notes:

1. Measurements at 2GHz obtained using demo board described in Figure 6 and 7.
2. OIP3 test condition: F_{RF1} - F_{RF2} = 10MHz with input power of -5dBm per tone measured at worst side band
3. Use proper biasing, heat sink and de-rating to ensure maximum channel temperature is not exceeded. See absolute maximum ratings and application note (if applicable) for more details.

Sparameter^[1] (Vdd = 5V, Vctrl = 5V, T= 25C, matched 50W)

freq (GHz)	S11 (dB)	S11 (ang)	S21 (dB)	S21 (ang)	S12 (dB)	S12 (ang)	S12 (dB)	S12 (ang)
0.1	-0.04	176.70	-70.03	-36.83	-76.06	67.88	-0.06	-166.80
0.2	-0.05	173.40	-69.11	-164.30	-79.63	-176.10	-0.08	179.60
0.3	-0.07	170.00	-52.75	164.10	-87.42	49.34	-0.10	171.70
0.4	-0.08	166.70	-41.46	120.10	-79.72	39.40	-0.11	165.20
0.5	-0.07	163.20	-37.01	88.00	-79.94	-16.38	-0.11	159.20
0.6	-0.07	160.30	-30.30	80.56	-78.30	31.13	-0.11	154.00
0.7	-0.09	156.20	-24.70	66.14	-72.20	6.69	-0.15	147.30
0.8	-0.13	151.50	-19.38	52.01	-68.93	-8.45	-0.24	139.60
0.9	-0.16	146.30	-14.11	37.37	-63.89	-23.91	-0.36	130.60
1	-0.25	140.10	-8.82	20.35	-58.43	-39.09	-0.66	119.50
1.1	-0.39	132.40	-3.45	-0.53	-52.67	-58.35	-1.23	105.10
1.2	-0.67	123.00	1.81	-26.90	-46.85	-82.60	-2.47	86.74
1.3	-1.20	110.60	6.57	-59.93	-41.51	-113.90	-5.07	64.05
1.4	-2.14	93.94	10.43	-98.05	-37.06	-150.20	-9.76	38.58
1.5	-4.08	69.50	13.27	-138.80	-33.67	170.40	-17.08	-1.40
1.6	-8.45	30.03	14.97	178.50	-31.42	128.90	-17.55	-98.94
1.7	-14.67	-53.24	15.37	137.60	-30.56	88.72	-11.37	-146.90
1.8	-11.24	-133.80	14.96	102.70	-30.60	54.41	-8.61	-174.70
1.9	-8.55	-166.60	14.38	73.52	-30.87	25.75	-7.72	163.90
2	-7.84	173.40	14.03	47.67	-30.97	0.88	-7.98	145.40
2.1	-8.09	157.00	13.90	22.87	-30.80	-23.49	-8.82	126.90
2.2	-9.18	141.90	13.88	-1.78	-30.56	-47.55	-10.06	107.70
2.3	-11.45	125.80	13.91	-27.25	-30.27	-72.78	-11.64	84.52
2.4	-16.04	104.20	13.87	-53.92	-30.06	-99.34	-13.01	52.89
2.5	-26.08	25.41	13.61	-81.73	-30.07	-127.20	-12.93	11.98
2.6	-16.02	-72.84	13.04	-109.90	-30.38	-155.60	-10.99	-27.64
2.7	-10.26	-98.16	12.13	-137.60	-31.06	176.40	-8.64	-59.34
2.8	-7.35	-116.60	11.02	-163.60	-31.91	149.80	-6.82	-84.58
2.9	-5.81	-132.10	9.90	172.20	-32.78	125.00	-5.63	-105.60
3	-5.15	-146.00	8.96	148.90	-33.45	101.00	-5.00	-124.30
3.1	-5.19	-159.30	8.35	125.20	-33.78	76.57	-4.86	-142.00
3.2	-6.14	-172.40	8.14	99.15	-33.73	49.28	-5.28	-160.30
3.3	-8.97	174.70	8.18	67.31	-33.39	16.05	-6.57	178.20
3.4	-17.65	-173.50	7.94	26.38	-33.32	-26.60	-9.37	147.60
3.5	-10.97	-88.62	6.21	-23.86	-34.71	-79.10	-13.88	78.03
3.6	-4.58	-102.80	1.96	-75.10	-38.54	-132.80	-9.32	-17.13
3.7	-2.23	-119.50	-4.20	-116.10	-44.25	-177.90	-4.83	-60.44
3.8	-1.32	-132.10	-10.93	-145.60	-50.43	149.60	-2.79	-85.61
3.9	-0.85	-141.30	-17.48	-166.30	-55.85	126.20	-1.80	-102.50
4	-0.65	-148.10	-23.75	178.40	-61.68	106.60	-1.29	-114.70
4.5	-0.28	-169.10	-51.11	139.30	-70.87	131.50	-0.49	-148.30
5	-0.21	178.10	-65.45	125.80	-67.10	121.10	-0.32	-166.00
6	-0.20	159.20	-64.37	74.39	-63.92	80.04	-0.30	171.00
7	-0.25	142.90	-63.71	51.05	-63.00	52.48	-0.39	150.60
8	-0.40	125.60	-64.65	10.66	-64.16	13.56	-0.48	126.00
9	-0.72	102.90	-65.08	-41.23	-64.91	-41.81	-0.61	96.01
10	-1.16	70.07	-75.19	22.13	-82.42	10.39	-0.91	59.94
11	-3.34	32.59	-47.66	-53.33	-49.81	-52.18	-1.22	16.82
12	-3.71	5.47	-46.82	-164.30	-50.16	-169.80	-1.15	-30.33
13	-2.67	-38.97	-42.47	129.70	-44.69	132.80	-1.05	-67.56
14	-2.40	-78.93	-40.93	56.23	-42.63	56.34	-1.36	-90.05
15	-1.46	-108.40	-34.95	-17.52	-36.30	-15.59	-1.88	-101.40
16	-1.10	-132.60	-49.96	-91.42	-51.29	-78.40	-1.13	-116.50
17	-1.07	-155.20	-52.09	-82.22	-53.38	-73.93	-1.10	-131.40
18	-1.08	-177.50	-43.08	-78.38	-43.35	-76.63	-0.67	-139.50
19	-1.39	157.20	-45.84	-122.20	-46.84	-120.70	-0.68	-145.50
20	-2.68	117.40	-45.43	-140.20	-47.37	-116.90	-0.96	-151.30

Notes:

1. S-parameters are measured on a CPWG line fabricated on 0.010 inch thick Rogers® RO4350 material using TRL calibration technique. The input reference plane is at the end of the input lead whereas the output reference plane is at the end of the output lead.

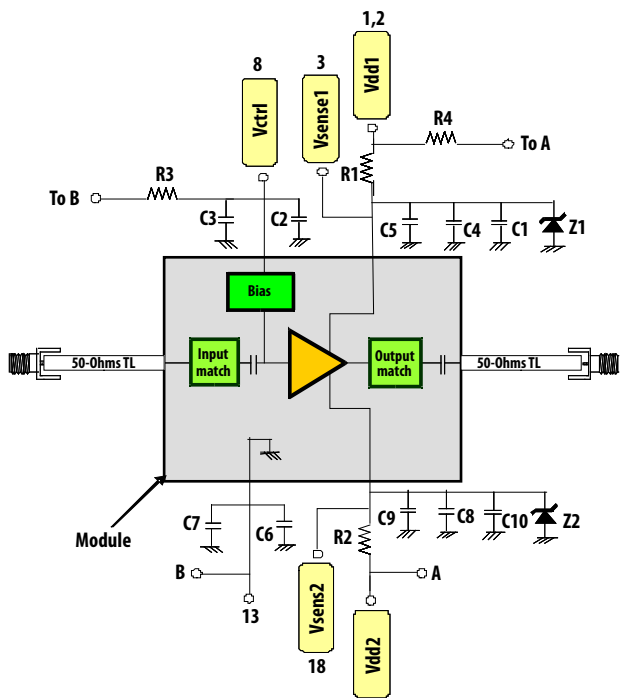

Circuit Symbol	Size	Value	Description
C1, C10	0805	2.2uF	Ceramic Chip Capacitor
C2, C4, C9	0402	0.1uF	Ceramic Chip Capacitor
C3, C5, C8	0402	10nF	Ceramic Chip Capacitor
C6, C7	0402	Not Used	N/A
R1, R2	1206	0 Ohm	Chip Resistor
R3	0402	Not Used	N/A
R4	0805	0 Ohm	Chip Resistor
Z1, Z2	0805	Optional	Zener Diode 5.6V (Optional)

Note:
 To supply Vdd1 and Vdd2 individually, remove R4 and supply Vdd1 from pin 1,2 and Vdd2 from pin 19,20

Figure 6. Demo board application schematics and components table

DC Pin Configuration of 20-pin Connector

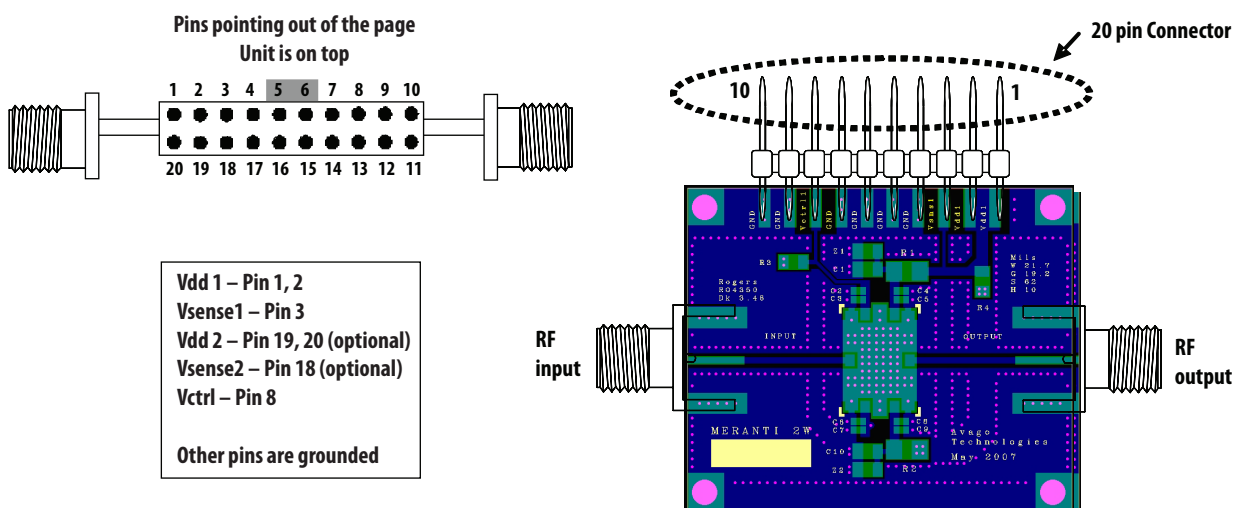

Figure 7. Demo board Layout

1. Recommended PCB material is 10 mils Rogers RO4350, with FR4 backing for mechanical strength.
2. Suggested component values may vary according to layout and PCB material.

ALM-32220 Typical Over-Temperature Performance

Vdd = 5V, Vctrl = 5V, Input Signal = CW unless stated otherwise.

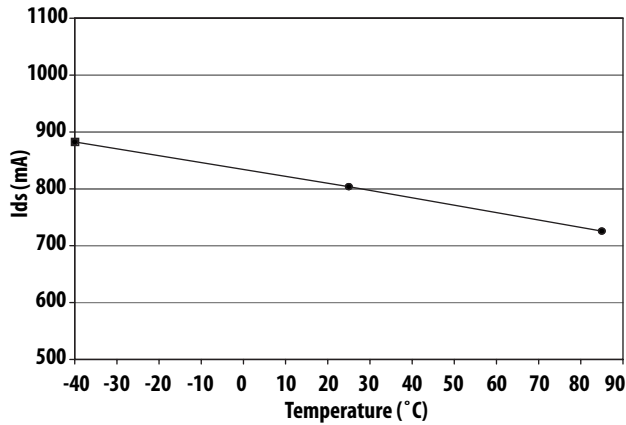

Figure 8. Over temperature Ids

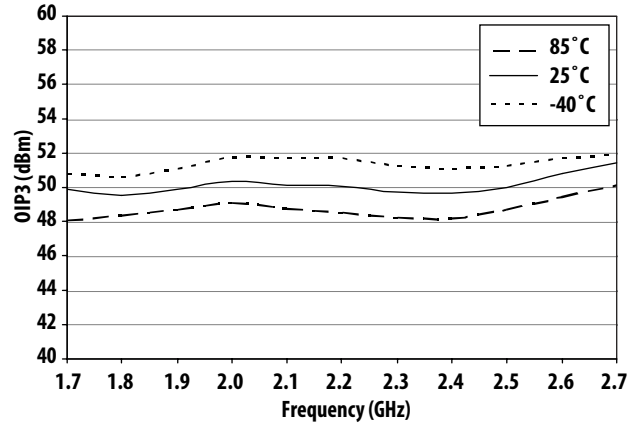

Figure 9. Over temperature OIP3 vs Frequency

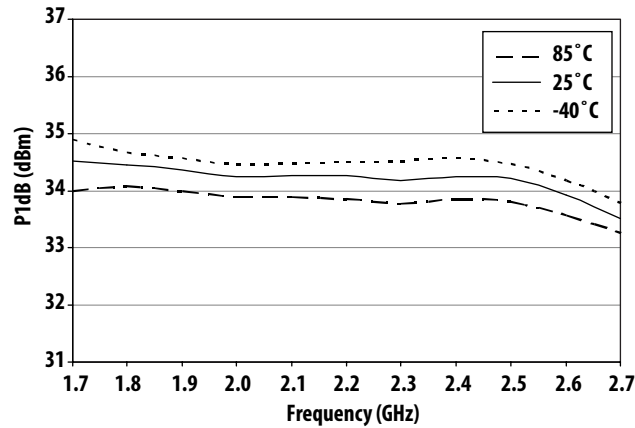

Figure 10. Over temperature P1dB vs Frequency

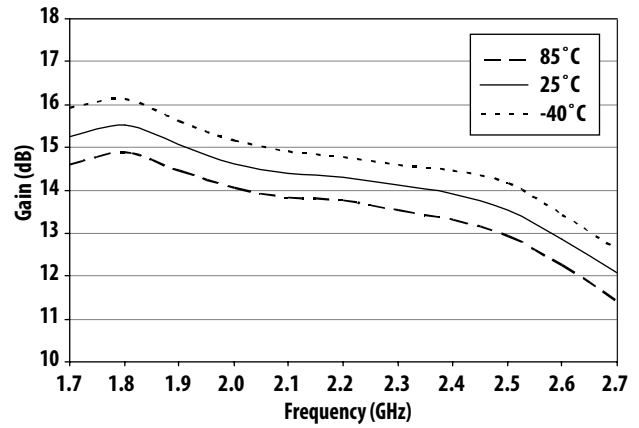

Figure 11. Over temperature Gain vs Frequency

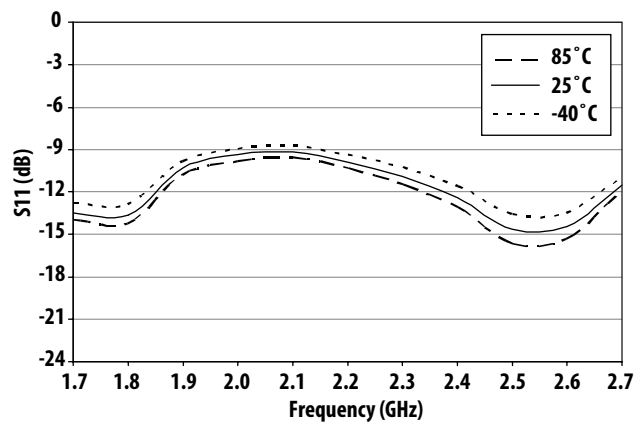

Figure 12. Over temperature S11 vs Frequency

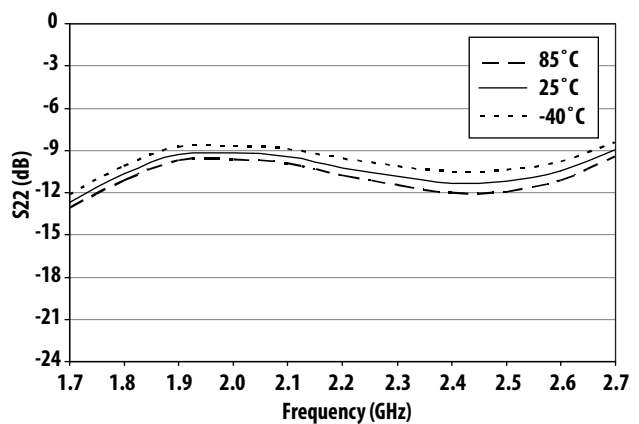

Figure 13. Over temperature S22 vs Frequency

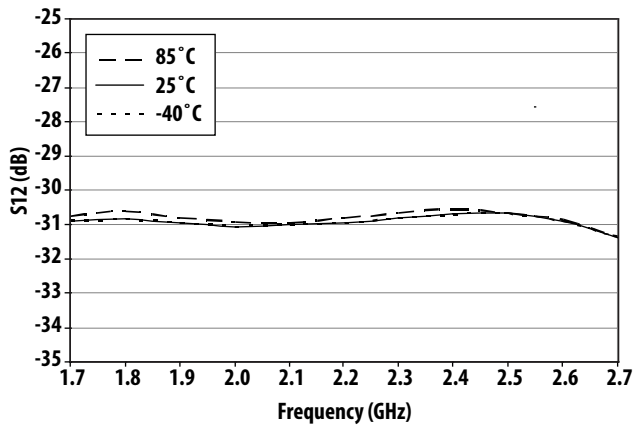

Figure 14. Over temperature S12 vs Frequency

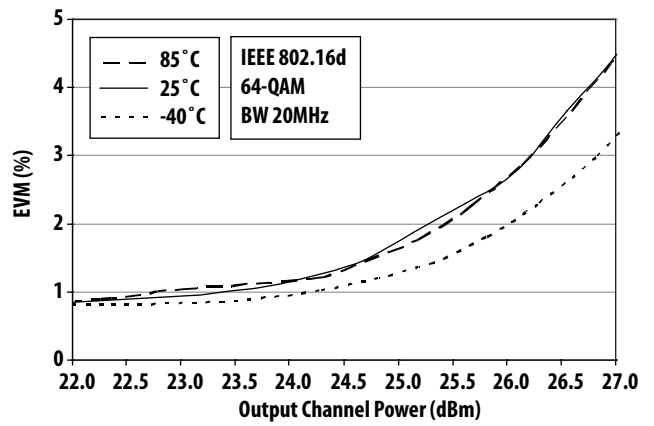

Figure 15. Over temperature WiMAX EVM vs Output Power @ 2.5GHz

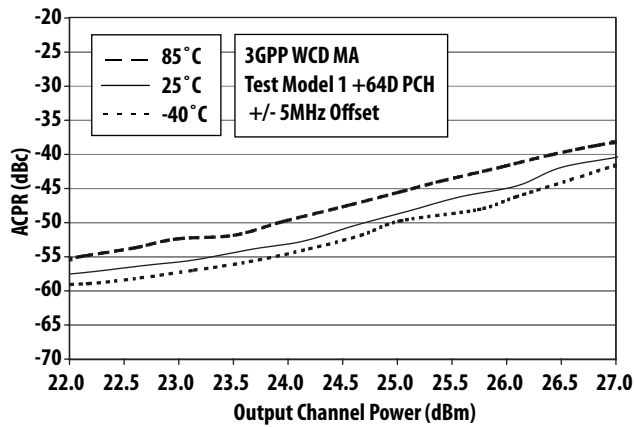

Figure 16. Over temperature WCDMA ACPR vs Channel Power @ 2.14GHz

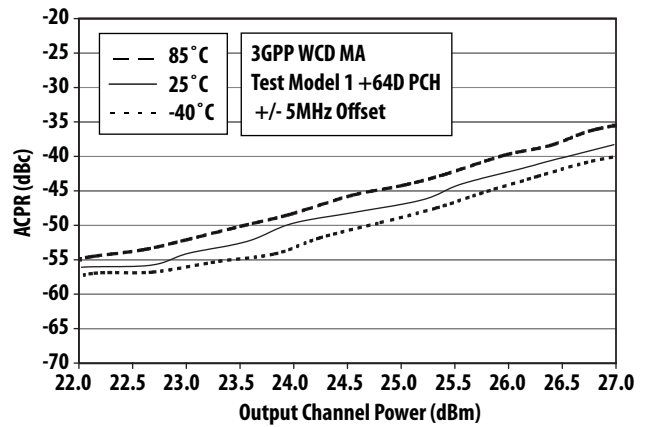

Figure 17. Over temperature WCDMA ACPR vs Channel Power @ 2.5GHz

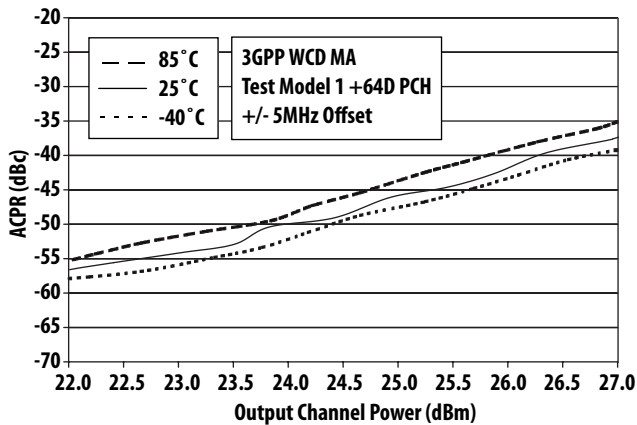

Figure 18. Over temperature WCDMA ACPR vs Channel Power @ 2.6GHz

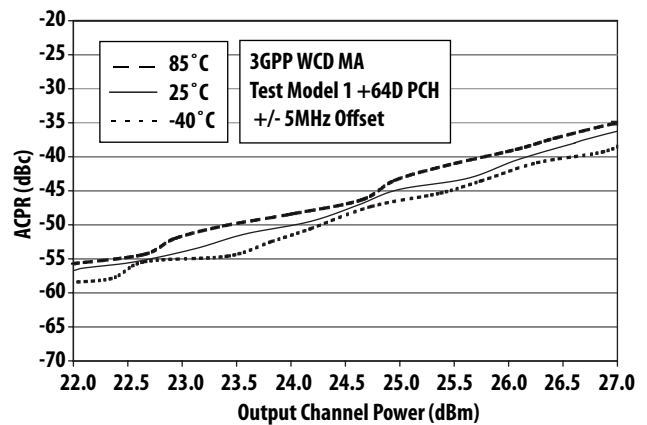
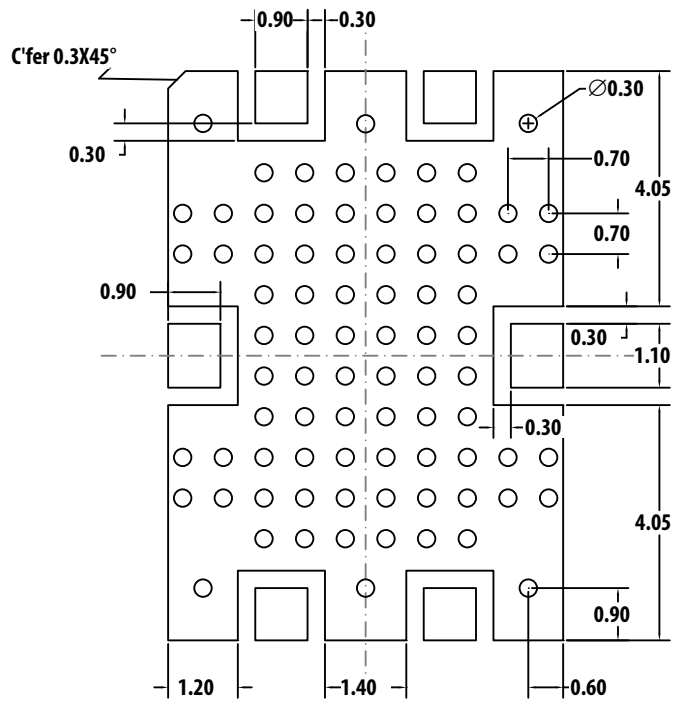
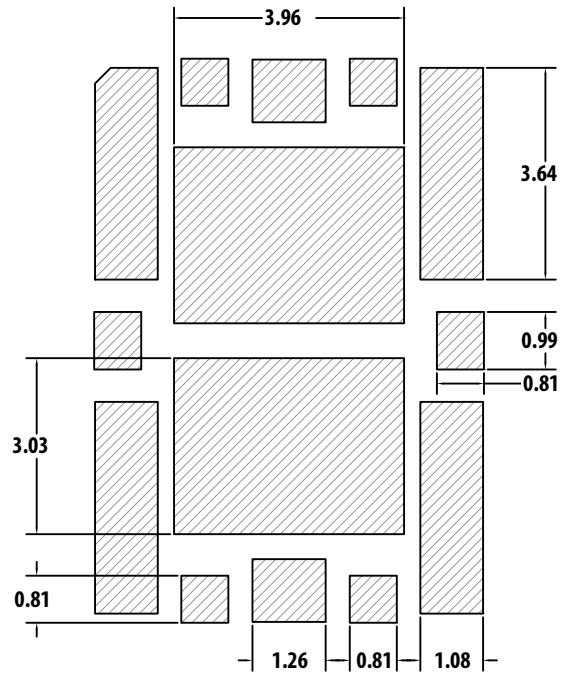

Figure 19. Over temperature WCDMA ACPR vs Channel Power @ 2.7GHz

PCB Layout and Stencil Design



PCB Land Pattern (Top View)



Stencil Outline

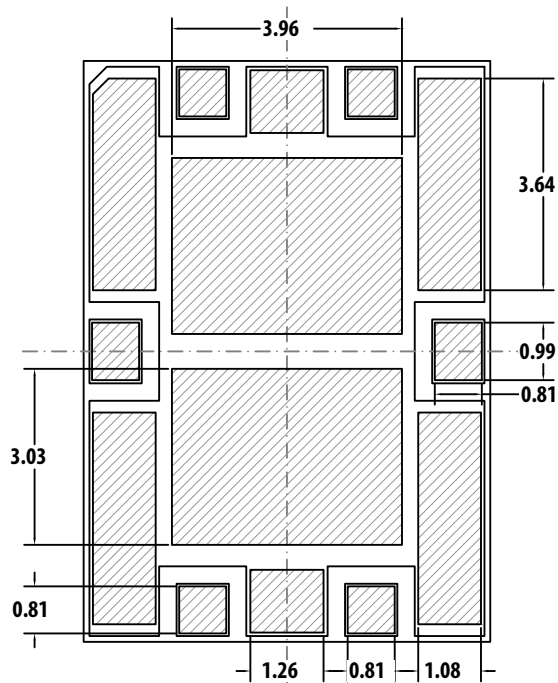

Combined PCB and stencil layout Land Pattern (Top View)

Note:
All dimensions are in millimeters.

MCOB 7 x 10 Package Dimensions

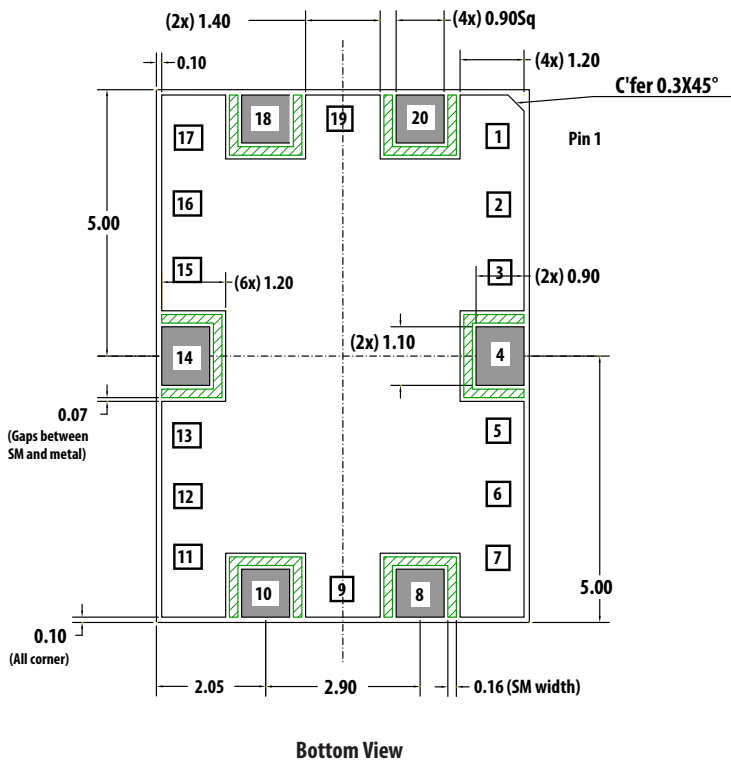
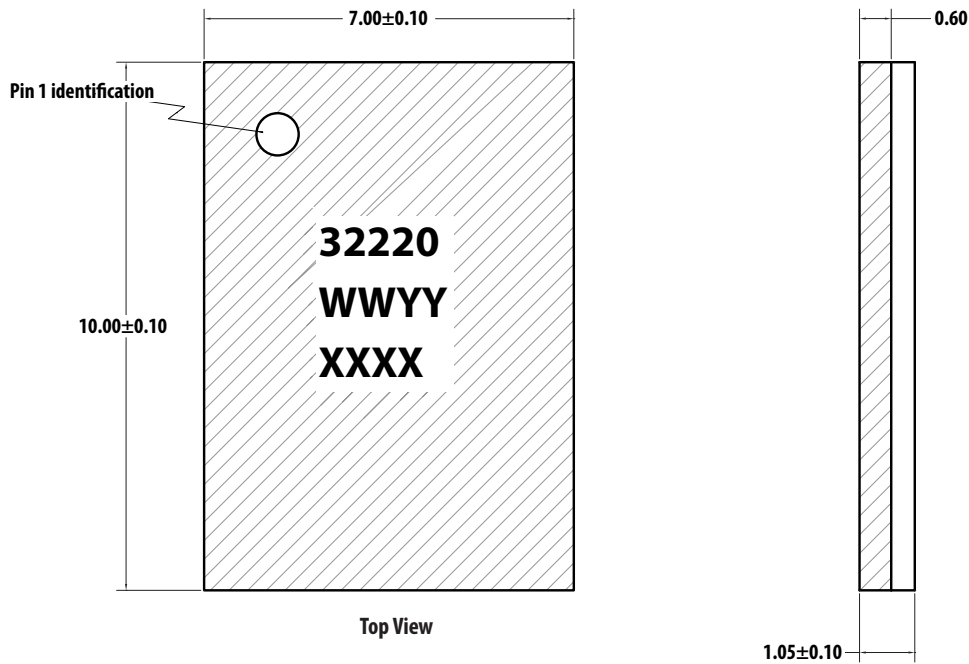

- Notes:
1. All dimensions are in millimeters
 2. Dimensions are inclusive of plating
 3. Dimensions are exclusive of mold flash and metal burr

Part Number Ordering Information

Part Number	No. of Devices	Container
ALM-32220-TR1G	1000	13" Reel
ALM-32220-TR2G	3000	13" Reel
ALM-32220-BLKG	100	antistatic bag

Product Family

Output Power	Frequency Band		
	700MHz-1GHz	1.7- 2.7GHz	3.3-3.9GHz
0.5W	MGA-30116	MGA-30216	MGA-30316
1W	ALM-31122	ALM-31222	ALM-31322
2W	ALM-32120	ALM-32220	ALM-32320

Device Orientation

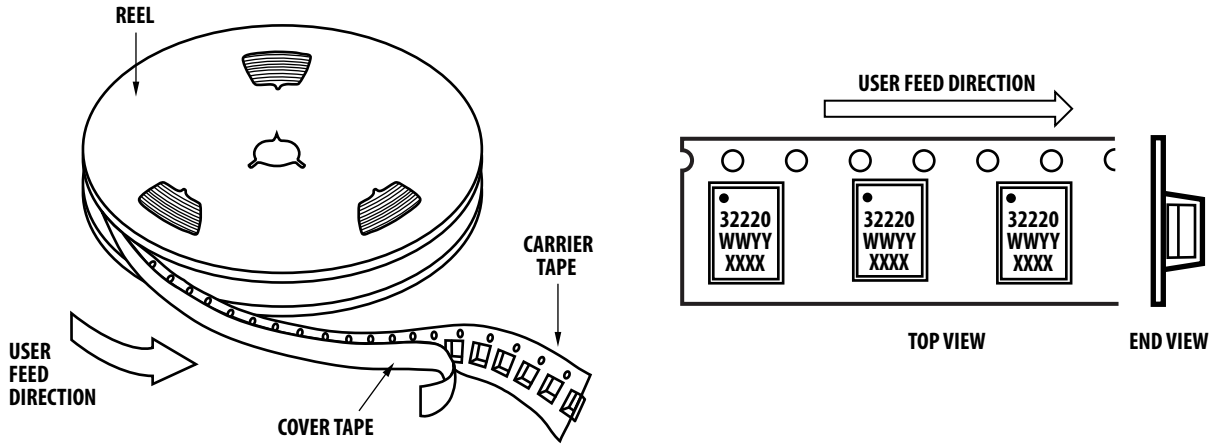

Tape Dimensions

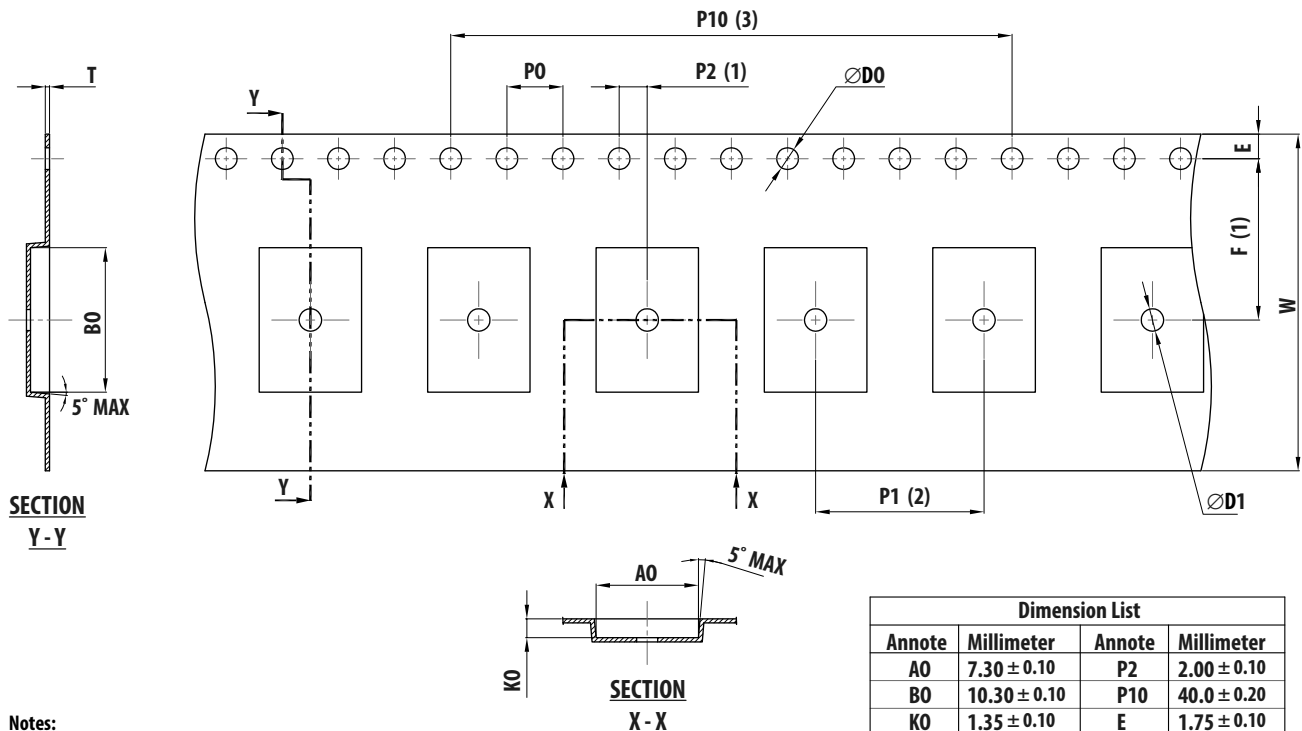

Notes:

1. Measure from centerline of sprocket hole to centerline of pocket.
2. Measure from centerline of pocket to centerline of pocket.
3. Pitch tolerance from sprocket hole, 10 pitch cumulative tolerance is $\pm 0.20\text{mm}$.
4. Allowable camber to be 1mm per 250mm in length.

Dimension List			
Annote	Millimeter	Annote	Millimeter
A0	7.30 ± 0.10	P2	2.00 ± 0.10
B0	10.30 ± 0.10	P10	40.0 ± 0.20
K0	1.35 ± 0.10	E	1.75 ± 0.10
D0	$1.50^{+0.10}_{-0}$	F	11.50 ± 0.10
D1	1.60 ± 0.10	W	24.00 ± 0.30
P0	4.00 ± 0.10	T	0.31 ± 0.03
P1	12.00 ± 0.10		

Reel Dimensions – 13 Inch

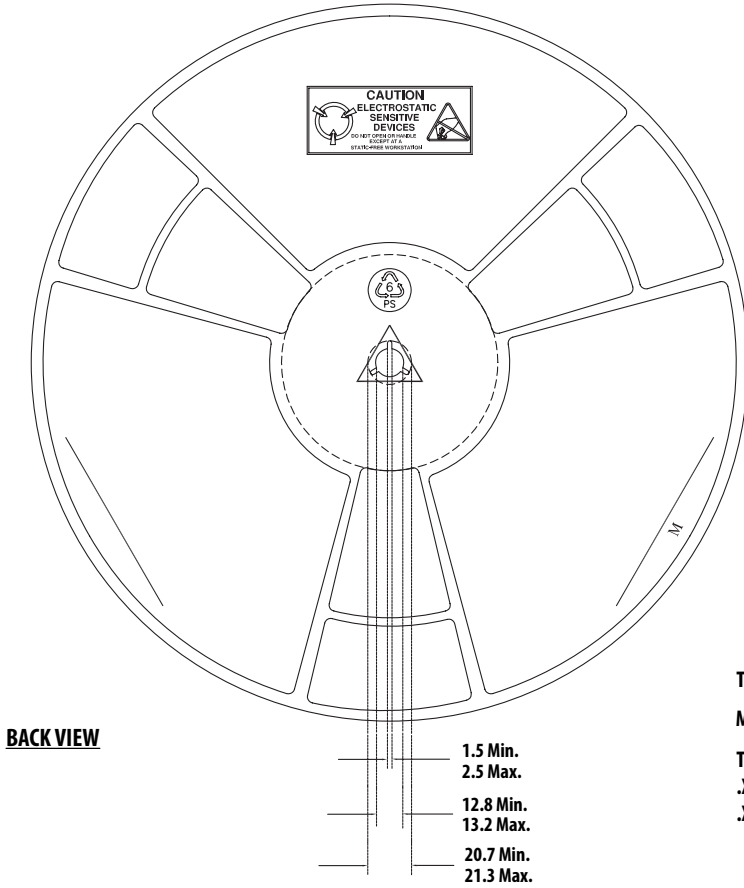
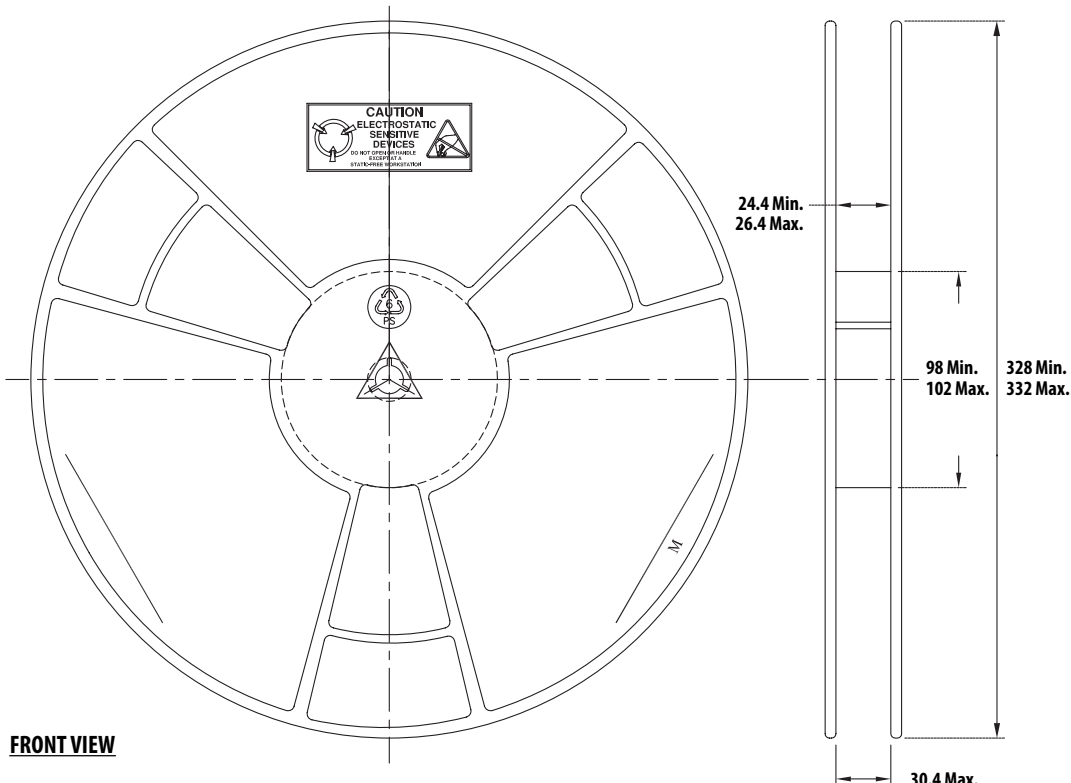

TAIPEX (M) SDN BHD
Measurements in mm
Tolerance:
.X = ±0.25
.XX = ±0.13

For product information and a complete list of distributors, please go to our web site: www.avagotech.com

Avago, Avago Technologies, and the A logo are trademarks of Avago Technologies in the United States and other countries. Data subject to change. Copyright © 2005-2014 Avago Technologies. All rights reserved. AV02-1146EN - November 5, 2014

