

ALM-31122
 700MHz - 1GHz
 1-Watt High Linearity Amplifier



Data Sheet

Description

Avago Technologies' ALM-31122 is a high linearity 1 Watt PA with good OIP3 performance and exceptionally good PAE at 1dB gain compression point, achieved through the use of Avago Technologies' proprietary 0.25um GaAs Enhancement-mode pHEMT process.

All matching components are fully integrated within the module. This makes the ALM-31122 extremely easy to use. The adjustable temperature-compensated internal bias circuit allows the device to be operated at either class A or class AB operation.

The ALM-31122 is housed inside a miniature 5.0 x 6.0 x 1.1 mm³ 22-lead multiple-chips-on-board (MCOB) module package.

Component Image

5.0 x 6.0 x 1.1 mm³ 22-lead MCOB

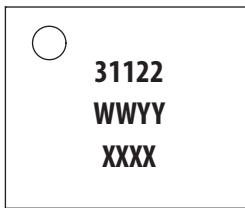

Top View

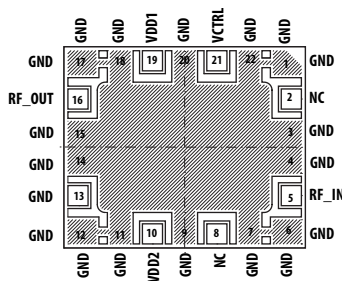

Bottom View

Notes:
 Package marking provides orientation and identification
 "31122" = Device Part Number
 "WWYY" = Work week and Year of manufacture
 "XXXX" = Last 4 digit of Lot number

Features

- Fully matched, input and output
- High linearity and P1dB
- Unconditionally stable across load condition
- Built-in adjustable temperature-compensated internal bias circuitry
- GaAs E-pHEMT Technology^[1]
- 5V supply
- Excellent uniformity in product specifications
- Tape-and-Reel packaging option available
- MSL-3 and Lead-free
- High MTTF for base station application

Specifications

900 MHz; 5V, 394mA (typical)

- 15.6 dB Gain
- 47.6 dBm Output IP3
- 31.6 dBm Output Power at 1dB gain compression
- 52.5% PAE at P1dB
- 2 dB Noise Figure

Applications

- Class A driver amplifier for GSM/CDMA Base Stations.
- General purpose gain block.

Note:

1. Enhancement mode technology employs positive gate voltage, thereby eliminating the need of negative gate voltage associated with conventional depletion mode devices.



Attention: Observe precautions for handling electrostatic sensitive devices.
 ESD Machine Model = 80V
 ESD Human Body Model = 200V
 Refer to Avago Application Note A004R: Electrostatic Discharge, Damage and Control.

Absolute Maximum Rating ^[2] T_A=25°C

Symbol	Parameter	Units	Absolute Max.
V _{dd,max}	Device Voltage, RF output to ground	V	5.5
I _{ds,max}	Device Drain Current	mA	750
V _{ctrl,max}	Control Voltage	V	5.5
P _{in,max}	CW RF Input Power	dBm	25
P _{diss}	Total Power Dissipation ^[4]	W	4.125
T _{j,max}	Junction Temperature	°C	150
T _{STG}	Storage Temperature	°C	-65 to 150

Thermal Resistance ^[3] $\theta_{jc} = 22 \text{ }^\circ\text{C/W}$
(V_{dd} = 5V, I_{dd} = 400mA, T_c = 85 °C)

Notes:

- Operation of this device in excess of any of these limits may cause permanent damage.
- Thermal resistance measured using Infra-Red measurement technique.
- Board (bottom of the device) temperature T_B is 25 °C. Derate 45.7mW/ °C for T_c > 59.3°C.

Product Consistency Distribution Charts^[5, 6]

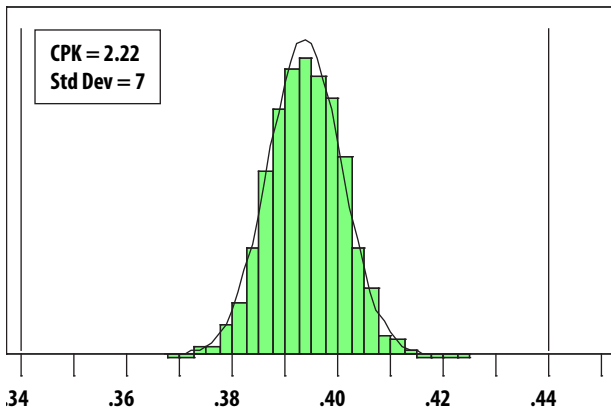

Figure 1. I_{ds}; LSL = 340mA, nominal = 394mA, USL = 440mA

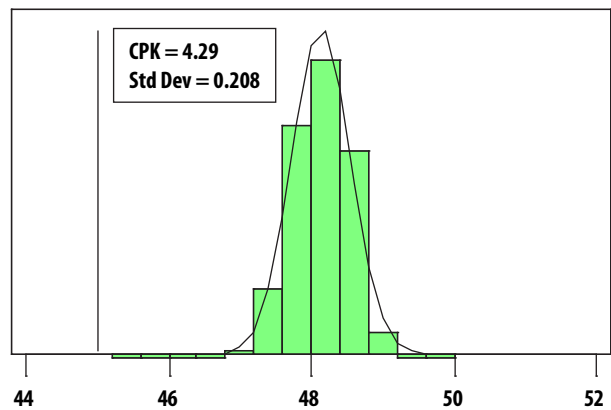

Figure 2. OIP3; LSL = 45dBm, nominal = 47.6dBm

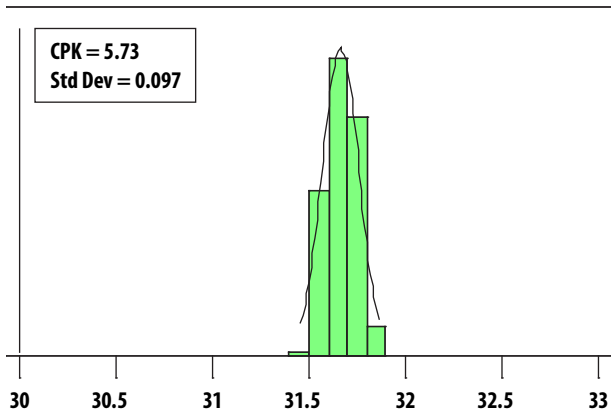

Figure 3. P1dB; LSL = 30dBm, nominal = 31.6dBm

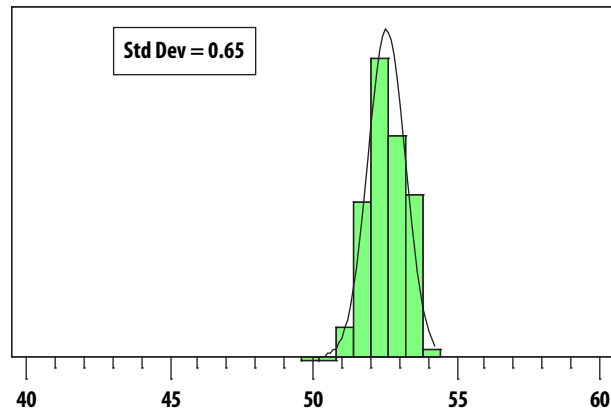

Figure 4. PAE at P1dB; nominal = 52.5%

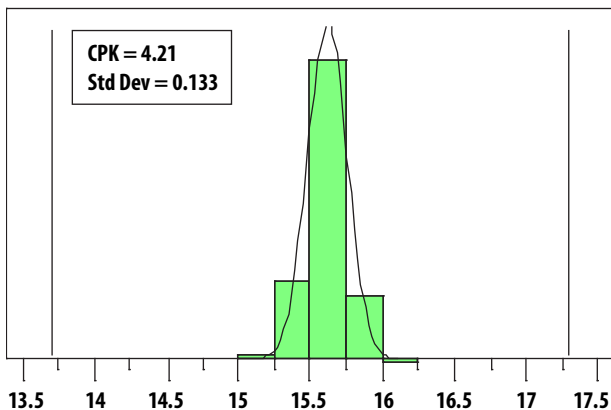

Figure 5. Gain; LSL=13.7dB, Nominal = 15.6dB, USL=17.3dB

Notes:

- Distribution data sample size is 500 samples taken from 3 different wafers. T_A = 25°C, V_{dd} = 5V, V_{ctrl} = 5V, RF performance at 900MHz unless otherwise specified. Future wafers allocated to this product may have nominal values anywhere between the upper and lower limits.
- Measurements are made on a production test board. Input trace losses have not been de-embedded from actual measurements.

Electrical Specifications [7]

$T_A = 25\text{ }^\circ\text{C}$, $V_{dd} = 5\text{V}$, $V_{ctrl} = 5\text{V}$, RF performance at 900MHz, measured on demo board (see Figure 7) unless otherwise specified.

Symbol	Parameter and Test Condition	Units	Min.	Typ.	Max.
I _{ds}	Quiescent current	mA	340	394	440
I _{ctrl}	V _{ctrl} current	mA	-	10.4	-
Gain	Gain	dB	13.7	15.6	17.3
OIP3 [8]	Output Third Order Intercept Point	dBm	45	47.6	-
OP1dB	Output Power at 1dB Gain Compression	dBm	30	31.6	-
PAE	Power Added Efficiency	%	-	52	-
NF	Noise Figure	dB	-	2.0	-
S11	Input Return Loss, 50Ω source	dB	-	-14	-
S22	Output Return Loss, 50Ω load	dB	-	-11	-
S12	Reverse Isolation	dB	-	-21	-

Notes:

- Measurements at 900MHz obtained using demo board described in Figure 6 and 7.
- 900MHz OIP3 test condition: $F_{RF1} - F_{RF2} = 10\text{MHz}$ with input power of -5dBm per tone measured at worse case side band.
- Use proper bias, heat sink and de-rating to ensure maximum channel temperature is not exceeded. See absolute maximum ratings and application note (if applicable) for more details.

S-Parameter [1] ($V_{dd}=5V$, $V_{ctrl}=5V$, $T=25\text{ }^\circ\text{C}$, matched 50 ohm)

Freq (GHz)	S11 (dB)	S11 (ang)	S21 (dB)	S21 (ang)	S12 (dB)	S12 (ang)	S22 (dB)	S22 (ang)
0.1	-0.21	170.70	-52.86	-128.00	-75.19	108.70	-0.17	-156.50
0.2	-0.35	161.60	-19.68	160.10	-69.03	78.96	-0.27	171.00
0.3	-0.42	150.90	-3.45	85.48	-54.89	34.54	-0.58	146.30
0.4	-0.67	137.20	3.06	36.55	-45.16	-4.56	-1.21	117.40
0.5	-3.13	114.90	14.64	-39.92	-31.55	-77.76	-8.42	84.35
0.6	-6.08	108.10	16.76	-112.30	-27.09	-145.70	-8.66	100.80
0.7	-11.05	92.08	17.39	-165.80	-24.32	164.70	-9.94	46.13
0.8	-22.24	150.50	17.05	147.20	-22.75	121.00	-12.84	-40.65
0.9	-13.89	-171.60	16.02	108.30	-22.05	84.80	-12.37	-106.60
1	-12.28	-171.90	15.01	74.51	-21.51	53.54	-13.92	-131.20
1.1	-11.29	-158.20	13.98	41.62	-21.10	22.81	-14.66	-105.50
1.2	-7.64	-153.00	12.48	8.19	-21.31	-8.66	-8.44	-96.92
1.3	-4.78	-164.90	10.27	-23.05	-22.33	-38.18	-4.43	-113.50
1.4	-3.54	177.90	7.72	-50.04	-23.80	-63.57	-2.51	-131.20
1.5	-3.49	158.60	5.27	-74.11	-25.25	-86.20	-1.61	-145.70
1.6	-4.81	134.00	3.07	-98.69	-26.57	-109.40	-1.15	-156.90
1.7	-9.43	91.41	0.70	-128.20	-28.14	-137.50	-0.87	-165.80
1.8	-12.59	-42.73	-3.08	-163.40	-31.29	-171.30	-0.63	-173.20
1.9	-4.89	-107.40	-9.14	165.30	-36.90	159.30	-0.45	180.00
2	-2.31	-135.00	-16.69	145.60	-44.39	144.20	-0.37	174.00
2.1	-1.32	-151.40	-25.44	138.90	-53.41	152.40	-0.33	168.80
2.2	-0.87	-162.30	-35.69	160.40	-58.13	-161.20	-0.32	164.40
2.3	-0.64	-170.10	-39.17	-138.30	-57.73	-137.60	-0.31	160.50
2.4	-0.49	-176.10	-37.81	-114.50	-58.96	-125.70	-0.30	157.10
2.5	-0.39	179.10	-37.60	-107.20	-59.13	-117.10	-0.28	154.10
2.6	-0.33	175.10	-38.37	-105.50	-59.77	-114.40	-0.26	151.40
2.7	-0.28	171.70	-39.97	-105.20	-61.10	-111.90	-0.25	148.80
2.8	-0.24	168.90	-42.39	-104.40	-62.32	-111.00	-0.24	146.50
2.9	-0.21	166.40	-45.88	-100.70	-66.48	-109.20	-0.23	144.40
3	-0.19	164.20	-51.32	-86.82	-72.62	-100.40	-0.23	142.40
3.1	-0.17	162.40	-56.24	-25.93	-82.53	-26.73	-0.25	140.60
3.2	-0.15	160.70	-50.53	24.01	-69.17	47.53	-0.26	138.90
3.3	-0.13	159.10	-45.93	34.95	-63.56	51.76	-0.28	137.30
3.4	-0.12	157.70	-43.01	37.64	-60.05	49.60	-0.30	135.80
3.5	-0.12	156.50	-40.85	38.27	-57.50	48.46	-0.34	134.30
3.6	-0.11	155.30	-39.23	38.18	-55.56	49.31	-0.37	133.00
3.7	-0.11	154.20	-37.82	37.49	-53.64	47.22	-0.40	131.70
3.8	-0.11	153.20	-36.58	36.30	-52.02	47.15	-0.41	130.30
3.9	-0.11	152.10	-35.45	34.87	-50.52	44.12	-0.41	128.90
4	-0.11	151.10	-34.48	33.28	-49.22	42.05	-0.41	127.20

Freq (GHz)	S11 (dB)	S11 (ang)	S21 (dB)	S21 (ang)	S12 (dB)	S12 (ang)	S22 (dB)	S22 (ang)
4.5	-0.16	145.70	-30.14	22.10	-43.46	30.05	-0.48	115.80
5	-0.25	138.60	-26.29	6.47	-38.50	14.88	-0.72	99.17
6	-0.60	111.30	-18.88	-40.80	-29.00	-30.87	-1.33	53.65
7	-1.26	72.16	-12.31	-120.80	-20.59	-109.80	-3.90	14.66
8	-0.76	54.50	-13.65	139.00	-20.23	150.00	-3.49	34.92
9	-0.96	51.67	-16.62	67.20	-22.02	77.87	-3.18	38.26
10	-1.18	44.48	-22.18	31.61	-26.48	40.97	-2.21	13.63
11	-2.02	3.39	-21.72	-2.12	-25.06	7.32	-2.23	-39.43
12	-1.72	-40.10	-19.37	-48.57	-21.90	-40.76	-2.89	-68.41
13	-1.27	-55.14	-21.92	-113.80	-23.76	-105.20	-3.01	-55.35
14	-1.68	-60.87	-21.34	-164.20	-22.61	-159.10	-2.61	-49.91
15	-2.11	-79.91	-21.53	172.30	-22.57	176.80	-2.33	-67.12
16	-3.48	-104.80	-16.43	77.65	-17.04	79.91	-7.85	-118.20
17	-2.37	-147.30	-19.82	-36.52	-20.23	-36.33	-3.15	-112.10
18	-3.33	-177.10	-26.00	-63.26	-26.15	-62.98	-8.11	-98.89
19	-3.99	167.90	-22.71	-89.07	-22.48	-89.84	-2.40	-112.30
20	-9.43	-178.90	-17.71	-177.20	-17.36	-178.30	-2.70	-133.80

Note:

1. S-parameters are measured on a CPWG line fabricated on 0.010 inch thick Rogers® RO4350 material using TRL calibration technique. The input reference plane is at the end of the input lead whereas the output reference plane is at the end of the output lead.

Demo Board Schematic

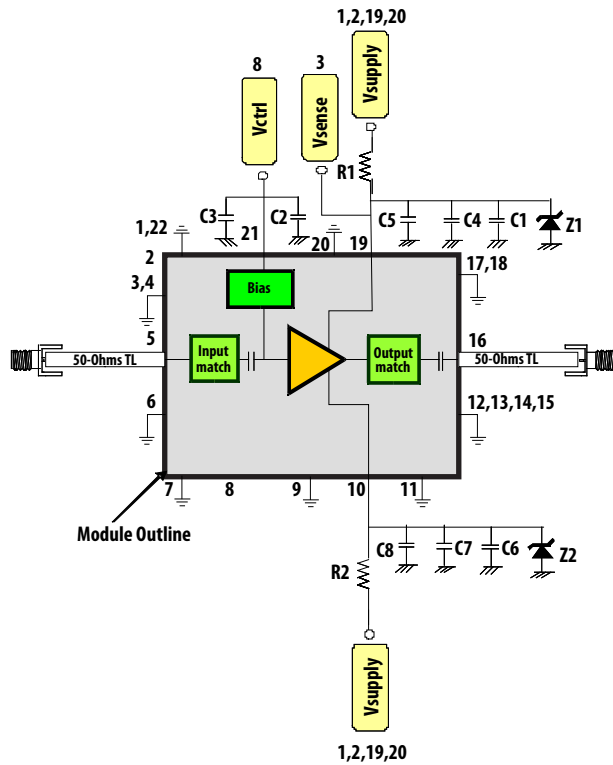

Circuit Symbol	Size	Value	Description
C1, C6	0805	2.2uF	Ceramic Chip Capacitor
C2, C4, C8	0402	0.1uF	Ceramic Chip Capacitor
C3, C5, C7	0402	10nF	Ceramic Chip Capacitor
R1	0805	0 Ohm	Chip Resistor
R2	0805	Not Used	N/A
Z1, Z2	0805	Not Used	Zener Diode 5.6V (Optional)

Figure 6. Demo board application schematics and components table

Demo Board Layout

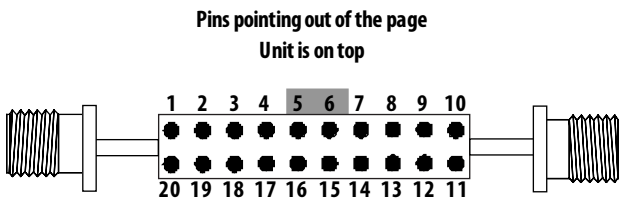

Pins 1,2,19,20 = Vsupply = Vdd
Pin 3 = Vsense (optional)
Pins 5,6,15,16 = GND
Pin 8 = Vctrl

Other pins are not used

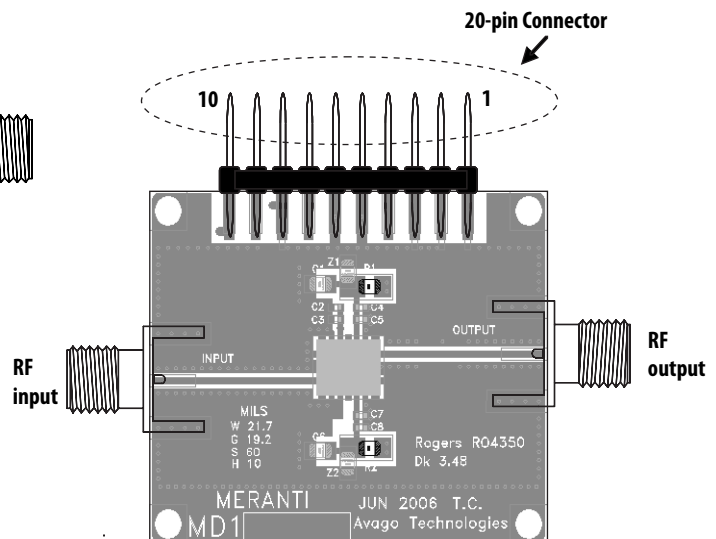

Figure 7. Demo Board Layout Diagram

1. Recommended PCB material is 10 mils Rogers RO4350, with FR4 backing for mechanical strength.
2. Suggested component values may vary according to layout and PCB material.

ALM-31122 Typical Performance

T_A = +25°C, V_{dd} = 5V, V_{ctrl} = 5V, Input Signal=CW unless stated otherwise.

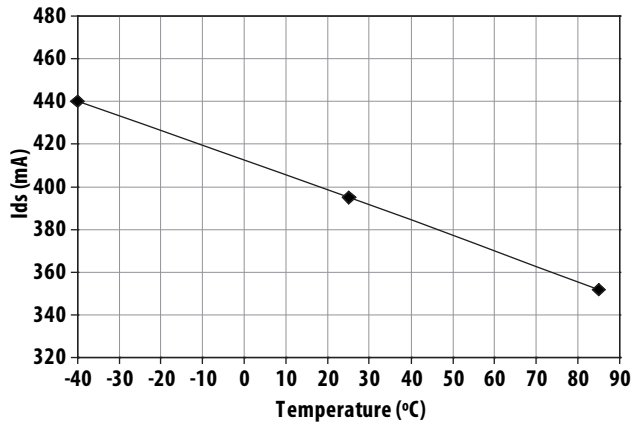

Figure 8. Ids vs Temperature

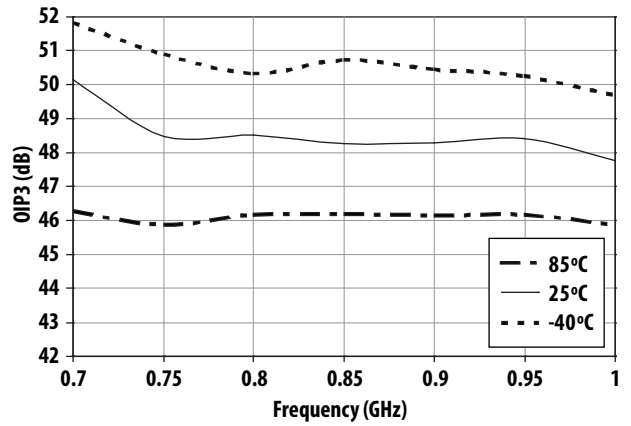

Figure 9. Over temperature OIP3 vs Frequency

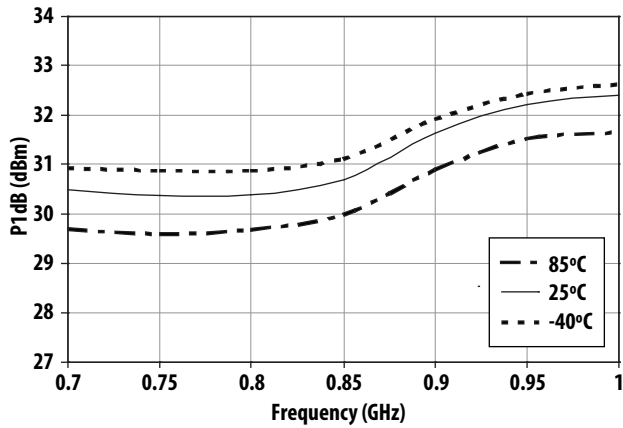

Figure 10. Over temperature P1dB vs Frequency

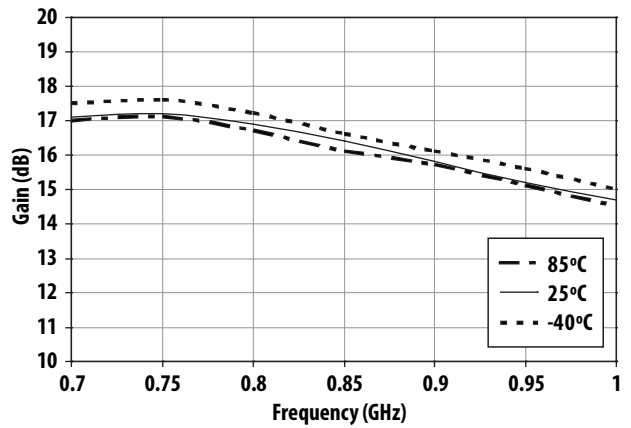

Figure 11. Over temperature Gain vs Frequency

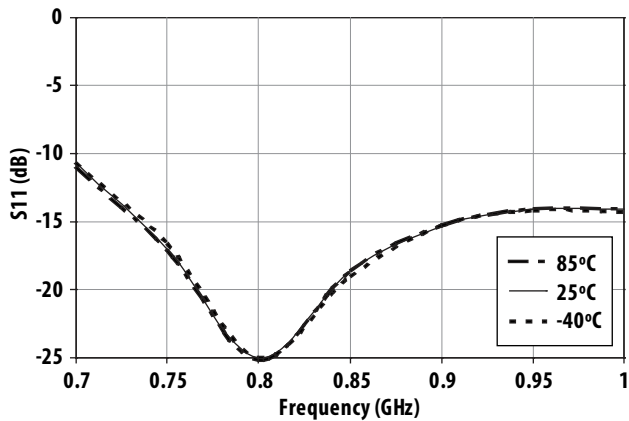

Figure 12. Over temperature S11 vs Frequency

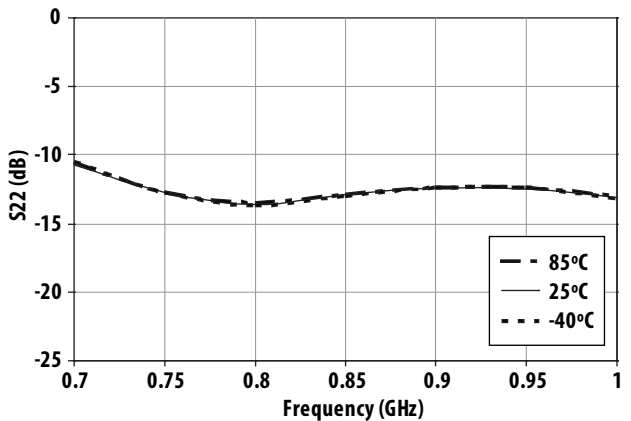

Figure 13. Over temperature S22 vs Frequency

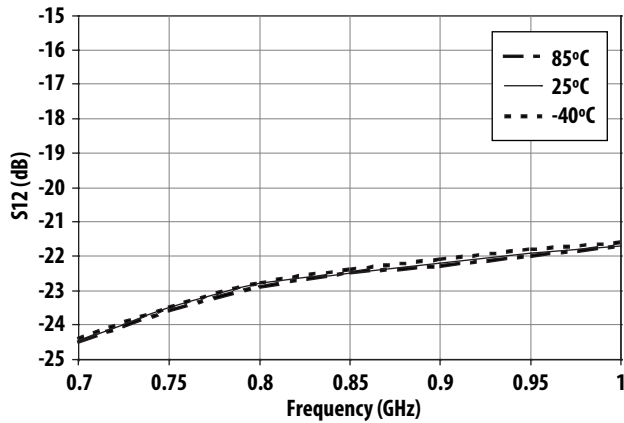

Figure 14. Over temperature S12 vs Frequency

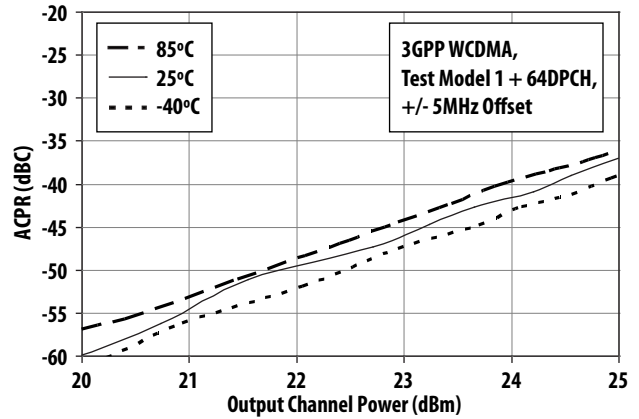
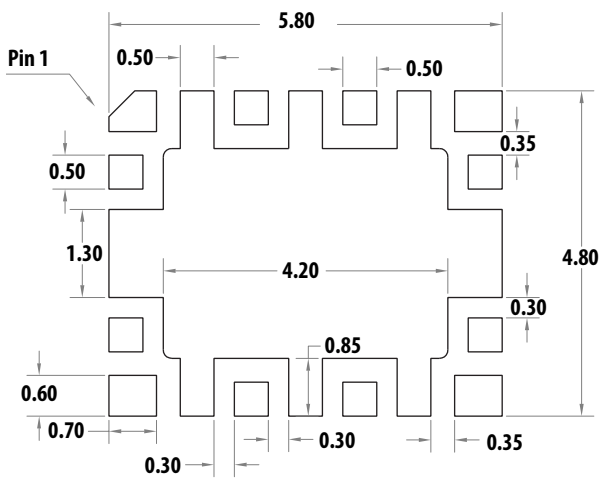
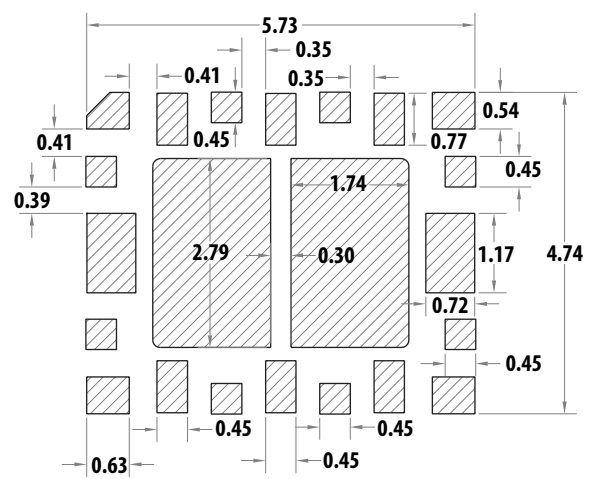

Figure 15. Over temperature ACPR vs Channel Power at 900MHz

PCB Layout and Stencil Design



PCB Land Pattern



Stencil Opening

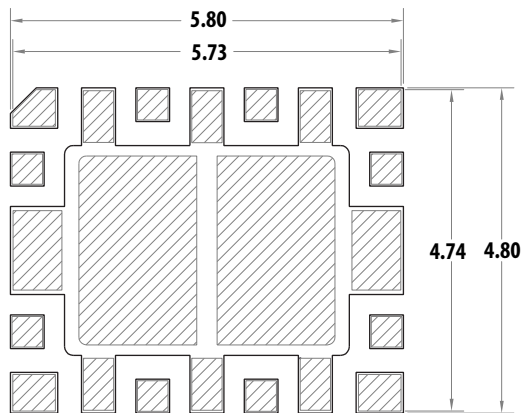

Combines Land Pattern and Stencil Layout

Note:
All dimensions are in millimeters.

Package Dimensions

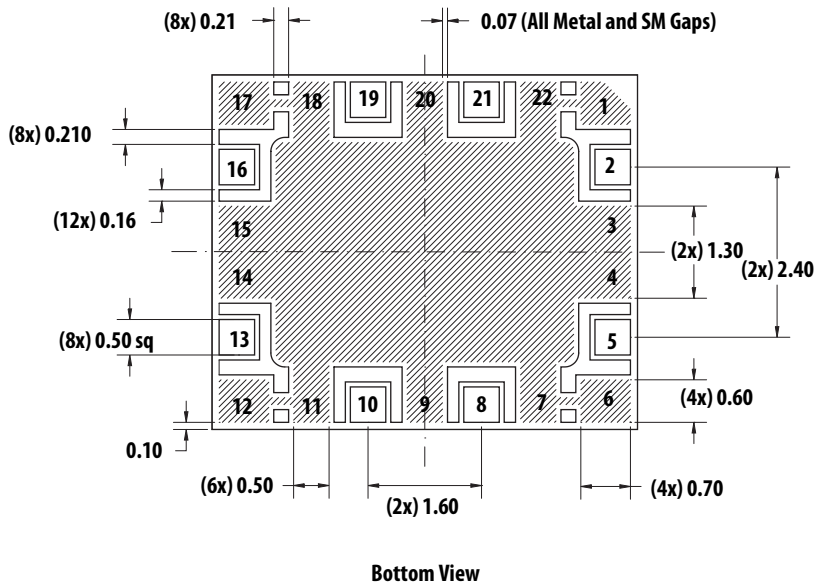
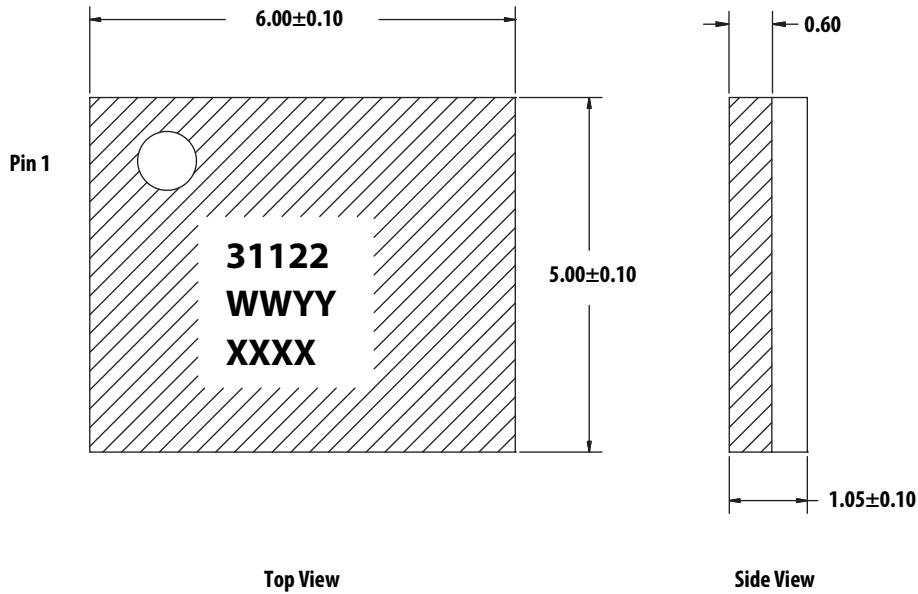

Notes:

1. All dimensions are in millimeters
2. Dimensions are inclusive of plating
3. Dimensions are exclusive of mold flash and metal burr

Part Number Ordering Information

Part Number	No. of Devices	Container
ALM31122-TR1G	1000	7" Reel
ALM31122-TR2G	3000	13" Reel
ALM31122-BLKG	100	antistatic bag

Product Family

Output Power	Frequency Band		
	700MHz-1GHz	1.7- 2.7GHz	3.3-3.9GHz
0.5W	MGA-30116	MGA-30216	MGA-30316
1W	ALM-31122	ALM-31222	ALM-31322
2W	ALM-32120	ALM-32220	ALM-32320

Device Orientation

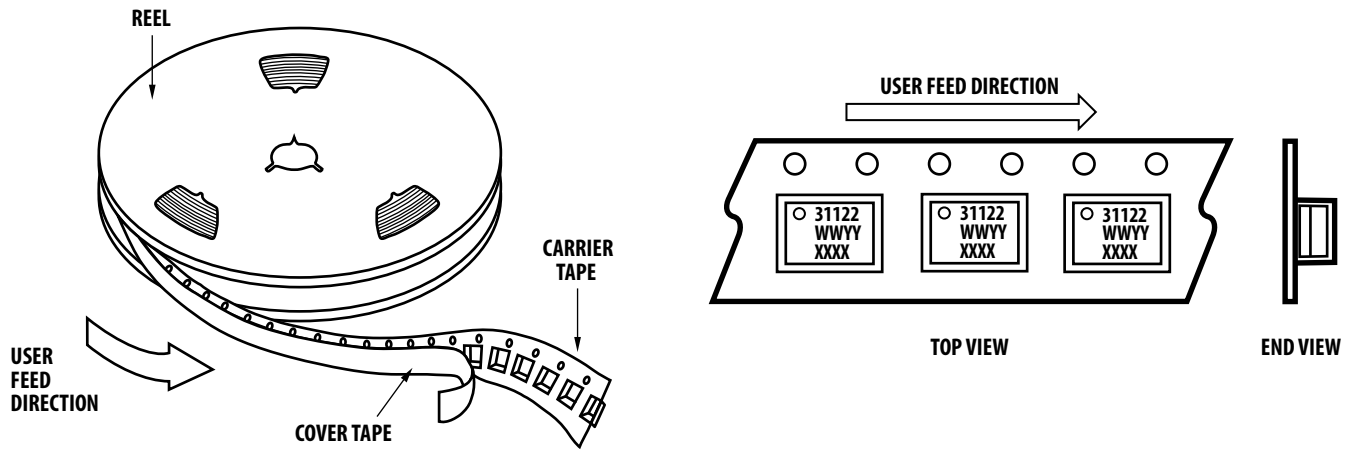

Tape Dimensions

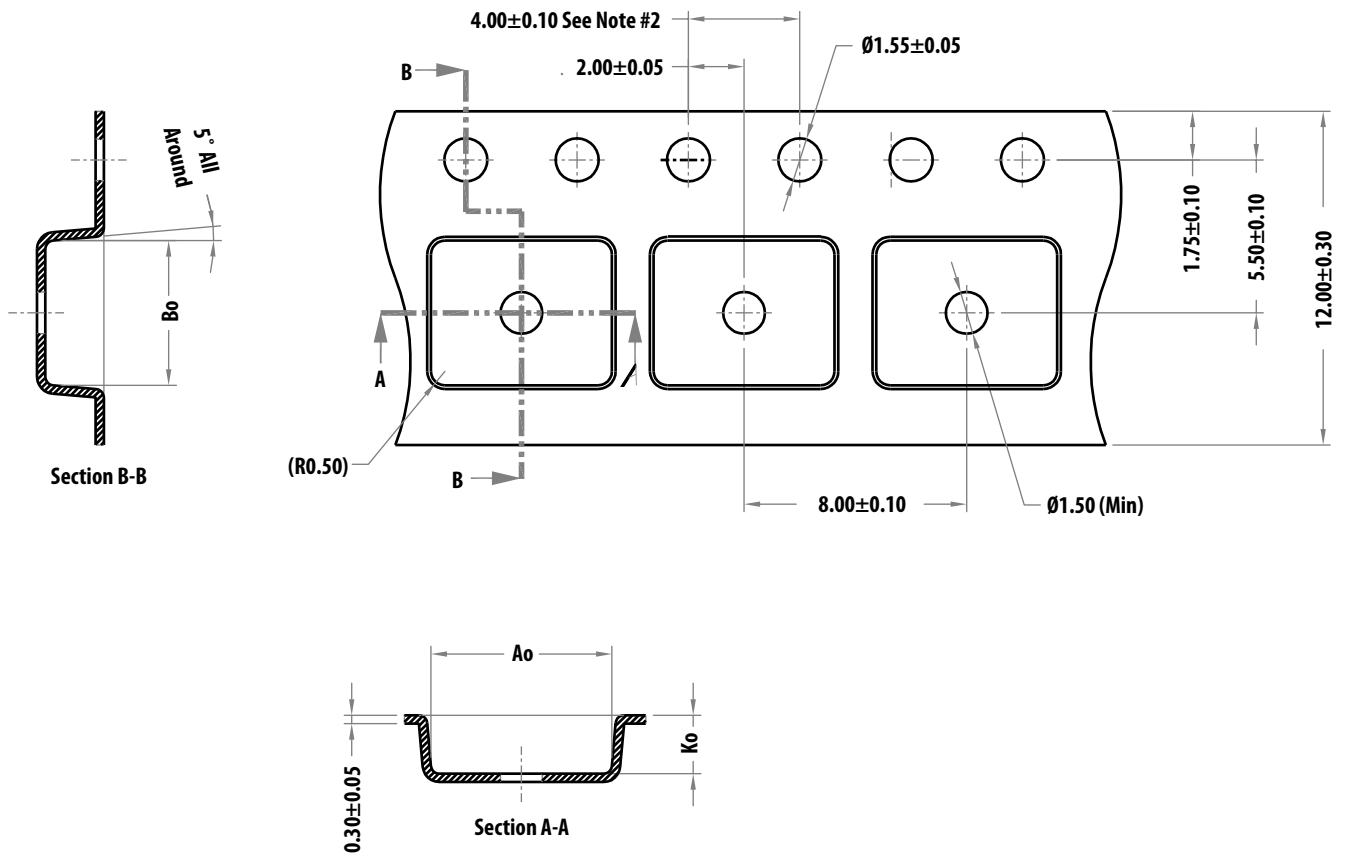

Reel Dimension - 7 inch

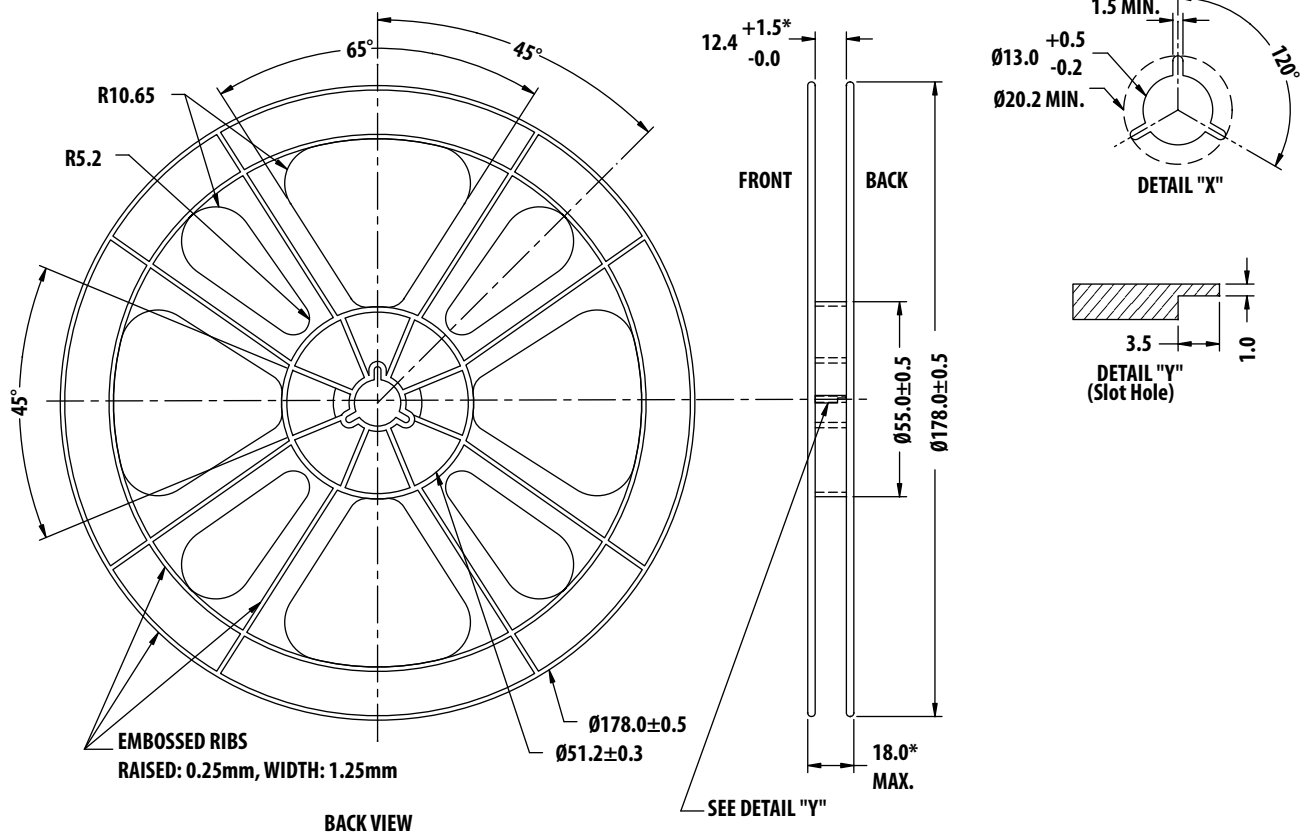
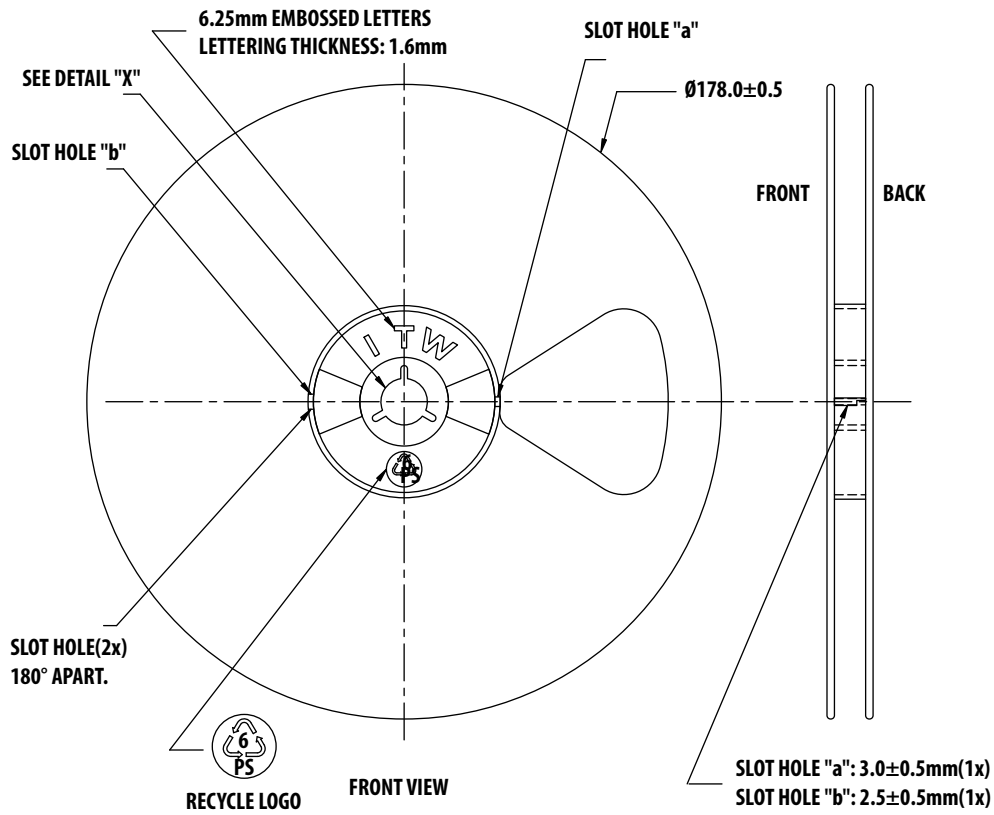

Reel Dimension - 13 inch

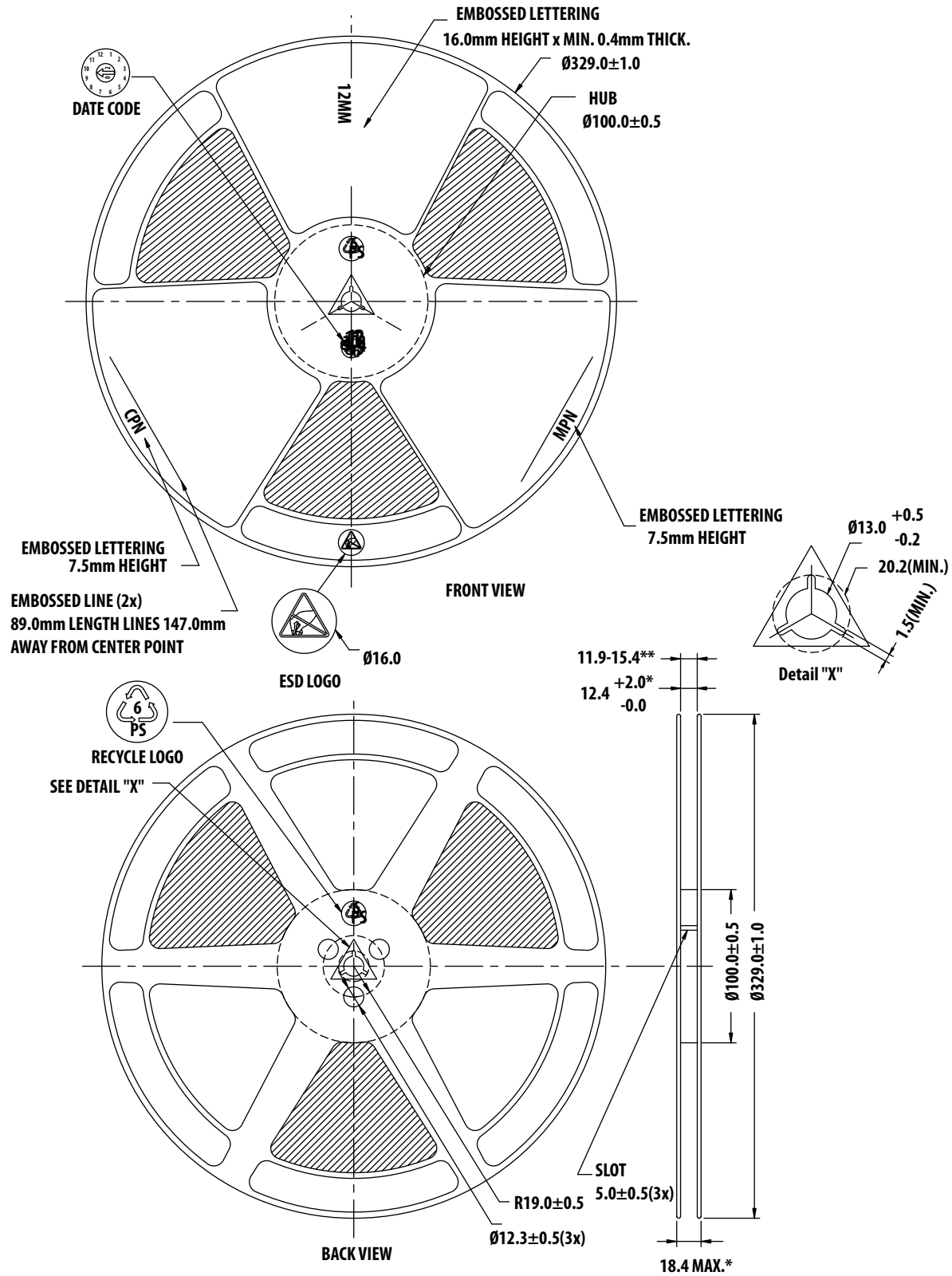

For product information and a complete list of distributors, please go to our web site: www.avagotech.com

Avago, Avago Technologies, and the A logo are trademarks of Avago Technologies Limited in the United States and other countries. Data subject to change. Copyright © 2005-2014 Avago Technologies Limited. All rights reserved. AV02-1178EN - February 10, 2014

