

FEATURES

- High-Definition Multimedia Interface (HDMI®) 1.4a features supported
 - All mandatory and additional 3D video formats supported
 - Extended colorimetry, including sYCC601, Adobe® RGB, Adobe YCC601, xvYCC extended gamut color
 - CEC 1.4-compatible
- HDMI 3 GHz receiver
 - 297 MHz maximum TMDS clock frequency
 - Supports 4k × 2k resolution
 - Xpressview® fast switching of HDMI ports
 - Up to 48-bit Deep Color with 36-/30-/24-bit support
 - High-bandwidth Digital Content Protection (HDCP) 1.4 support with internal HDCP keys
 - HDCP repeater support: up to 127 KSVs supported
 - Integrated CEC controller
 - Programmable HDMI equalizer
 - 5 V detect and Hot Plug™ assert for each HDMI port
- Audio support
 - Audio support including high bit rate (HBR) and Direct Stream Digital (DSD)
 - S/PDIF (IEC 60958-compatible) digital audio support
 - Supports up to four I²S outputs

- Advanced audio mute feature
- Dedicated, flexible audio output port
- Super Audio CD® (SACD) with DSD output interface
- HBR audio
 - Dolby® TrueHD
 - DTS-HD Master Audio™

General

- Interrupt controller with 2 interrupt outputs
- Standard identification (STDI) circuit
- Highly flexible, 48-bit pixel output interface
- 36-bit output for resolutions up to 1080p Deep Color
- 2 × 24-bit pass-through outputs for HDMI formats greater than 2.25 GHz
- Internal EDID RAM
- Any-to-any, 3 × 3 color space conversion (CSC) matrix
- 128-lead TQFP_EP, 14 mm × 14 mm package

APPLICATIONS

- Projectors
- Video conferencing
- HDTV
- AVR, HTiB
- Soundbar
- Video switch

FUNCTIONAL BLOCK DIAGRAM

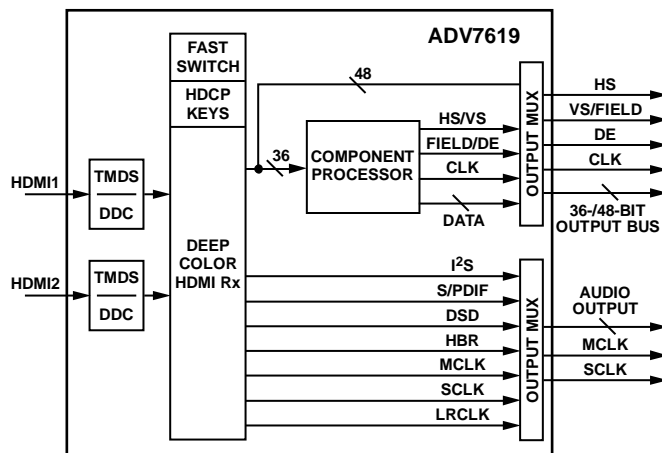

Figure 1.

TABLE OF CONTENTS

Features	1	Power Supply Recommendations.....	13
Applications.....	1	Power-Up Sequence	13
Functional Block Diagram	1	Power-Down Sequence.....	13
Revision History	2	Current Rating Requirements for Power Supply Design	13
General Description	3	Functional Overview.....	14
Detailed Functional Block Diagram	3	HDMI Receiver.....	14
Specifications.....	4	Component Processor (CP).....	14
Electrical Characteristics.....	4	Other Features	14
Data and I ² C Timing Characteristics.....	6	Pixel Input/Output Formatting	15
Absolute Maximum Ratings.....	8	Pixel Data Output Mode Features.....	15
Package Thermal Performance.....	8	Outline Dimensions	22
ESD Caution.....	8	Ordering Guide	22
Pin Configuration and Function Descriptions.....	9		

REVISION HISTORY

10/15—Rev. C to Rev. D

Changes to Table 3.....	6
Added Unit of Measure to Infrared Reflow Soldering Parameter, Table 4 and Operating Temperature Range Parameter, Table 4 .	8
Changes to Ordering Guide	22

1/14—Rev. B to Rev. C

Changes to Table 5.....	9
-------------------------	---

5/12—Rev. A to Rev. B

Changes to Features Section.....	1
Changes to General Description Section and Figure 2	3
Change to Table 1	4
Changes to Table 3.....	6
Changes to Figure 5; Deleted Figure 6, Renumbered Sequentially	7

Changes to Figure 7.....	9
Changes to Table 5.....	11
Changes to HDMI Receiver Section and Other Features Section..	14
Deleted Time-Division Multiplexed (TDM) Mode Section and Figure 9	15

9/11—Rev. 0 to Rev. A

Changes to General Description Section	3
Changes to Data Output Transition Time Typ Values, Table 3...6	6
Changes to Pin 113 Description.....	12
Changes to Pixel Input/Output Formatting Section.....	16
Added Endnote 1 to Table 7.....	17
Added Endnote 1 to Table 12.....	22
Changes to Ordering Guide	23

7/11—Revision 0: Initial Version

GENERAL DESCRIPTION

The **ADV7619** is a high quality, two input, one output (2:1) multiplexed High-Definition Multimedia Interface (HDMI®) receiver. The **ADV7619** is offered in professional (no HDCP keys) and commercial versions. The operating temperature range is 0°C to 70°C.

The **ADV7619** incorporates a dual input HDMI-capable receiver that supports all mandatory 3D TV formats defined in the HDMI 1.4a specification, HDTV formats up to 1080p 36-bit Deep Color/2160p 8-bit, and display resolutions up to 4k × 2k (3840 × 2160 at 30 Hz). It integrates an HDMI CEC controller that supports the capability discovery and control (CDC) feature.

The **ADV7619** incorporates Xpressview® fast switching on both input HDMI ports. Using the Analog Devices, Inc., hardware-based HDCP engine to minimize software overhead, Xpressview technology allows fast switching between both HDMI input ports in less than 1 sec.

Each HDMI port has dedicated 5 V detect and Hot Plug™ assert pins. The HDMI receiver also includes an integrated program-mable equalizer that ensures robust operation of the interface with long cables.

The **ADV7619** offers a flexible audio output port for audio data extraction from the HDMI stream. HDMI audio formats, including SACD via DSD and HBR, are supported by the **ADV7619**.

The HDMI receiver has advanced audio functionality, such as a mute controller, that prevents audible extraneous noise in the audio output.

The **ADV7619** contains one main component processor (CP), which processes video signals from the HDMI receiver up to 1080p 36-bit Deep Color. It provides features such as contrast, brightness and saturation adjustments, STDI detection block, free-run, and synchronization alignment controls.

For video formats with pixel clocks higher than 170 MHz, the video signals received on the HDMI receiver are output directly to the pixel port output. To accommodate the higher bandwidth required for these higher resolutions, the output on the pixel bus consists of two 24-bit buses running at up to 150 MHz: one bus contains the even pixels, and the other bus contains the odd pixels. When these two buses are combined, they allow the transfer of video data with pixel clocks up to 300 MHz. In this mode, both 4:4:4 RGB 8-bit and 4:2:2 12-bit are supported.

Fabricated in an advanced CMOS process, the **ADV7619** is provided in a 14 mm × 14 mm, 128-lead, surface-mount, RoHS-compliant TQFP_EP package and is specified over the 0°C to 70°C temperature range.

DETAILED FUNCTIONAL BLOCK DIAGRAM

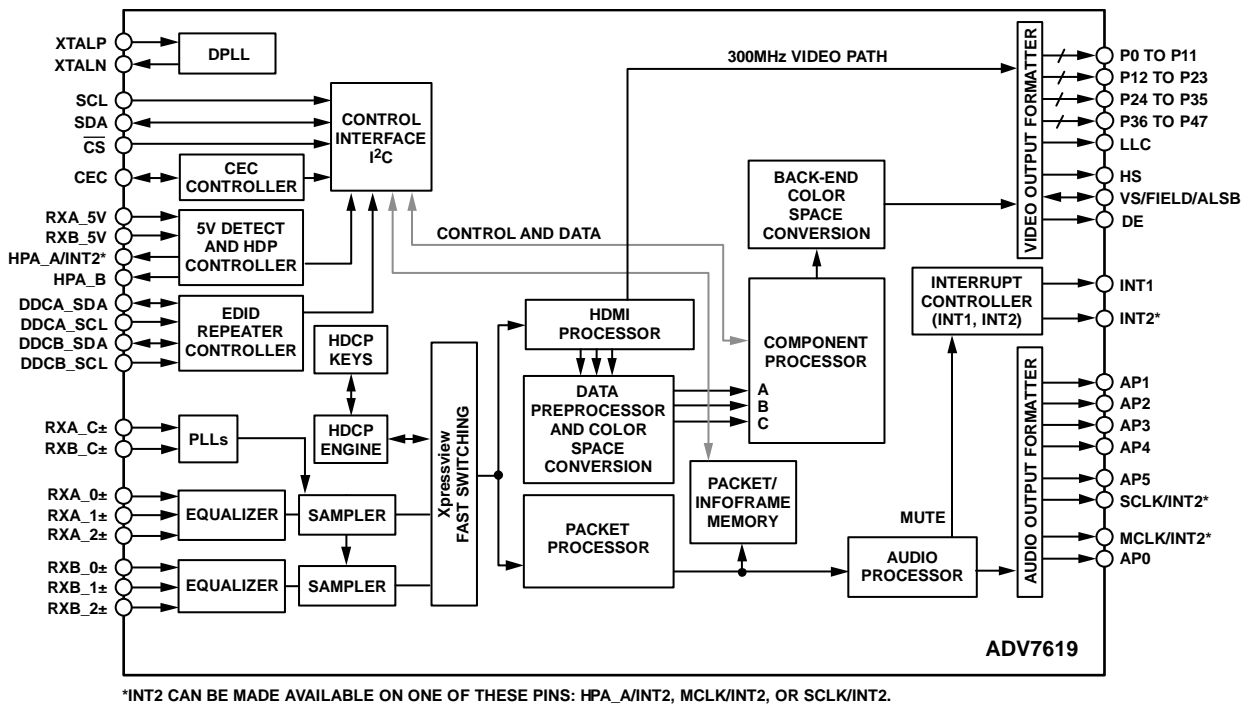

Figure 2.

SPECIFICATIONS

ELECTRICAL CHARACTERISTICS

DVDD = 1.71 V to 1.89 V, DVDDIO = 3.14 V to 3.46 V, PVDD = 1.71 V to 1.89 V, TVDD = 3.14 V to 3.46 V, CVDD = 1.71 V to 1.89 V, operating temperature range, unless otherwise noted.

Table 1.

Parameter	Symbol	Test Conditions/Comments	Min	Typ	Max	Unit
DIGITAL INPUTS ¹						
Input High Voltage	V _{IH}	XTALN and XTALP pins	1.2			V
		Other digital inputs	2			V
Input Low Voltage	V _{IL}	XTALN and XTALP pins			0.4	V
		Other digital inputs			0.8	V
Input Current	I _{IN}	RESET and CS pins		±45	±60	μA
		Other digital inputs		±10		μA
Input Capacitance	C _{IN}				10	pF
DIGITAL INPUTS (5 V TOLERANT) ¹						
Input High Voltage	V _{IH}	DDCA_SCL, DDCA_SDA, DDCB_SCL, and DDCB_SDA pins	2.6			V
Input Low Voltage	V _{IL}				0.8	V
Input Current	I _{IN}		-70		+70	μA
DIGITAL OUTPUTS ¹						
Output High Voltage	V _{OH}		2.4			V
Output Low Voltage	V _{OL}				0.4	V
High Impedance Leakage Current	I _{LEAK}	VS/FIELD/ALSB pin		±35	±60	μA
		HPA_A/INT2 and HPA_B pins			±70	μA
		Other digital outputs		±10		μA
Output Capacitance	C _{OUT}				20	pF
POWER REQUIREMENTS						
Digital Core Power Supply	DVDD		1.71	1.8	1.89	V
Digital I/O Power Supply	DVDDIO		3.14	3.3	3.46	V
PLL Power Supply	PVDD		1.71	1.8	1.89	V
Terminator Power Supply	TVDD		3.14	3.3	3.46	V
Comparator Power Supply	CVDD		1.71	1.8	1.89	V
CURRENT CONSUMPTION						
See Table 2						
Digital Core Power Supply	I _{DVDD}	Test Condition 1		268		mA
		Test Condition 2		186		mA
Digital I/O Power Supply	I _{DVDDIO}	Test Condition 1		9		mA
		Test Condition 2		10		mA
PLL Power Supply	I _{PVDD}	Test Condition 1		20		mA
		Test Condition 2		31		mA
Terminator Power Supply	I _{TVDD}	Test Condition 1		92		mA
		Test Condition 2		92		mA
Comparator Power Supply	I _{CVDD}	Test Condition 1		187		mA
		Test Condition 2		166		mA
POWER-DOWN CURRENT ²						
See Table 2, Test Condition 3						
Digital Core Power Supply	I _{DVDD_PD}			1.07		mA
Digital I/O Power Supply	I _{DVDDIO_PD}			0.034		mA
PLL Power Supply	I _{PVDD_PD}			0.691		mA
Terminator Power Supply	I _{TVDD_PD}			0.857		mA
Comparator Power Supply	I _{CVDD_PD}			0.053		mA
POWER-UP TIME	t _{PWRUP}			25		ms

¹ Data guaranteed by characterization.

² Data recorded during lab characterization.

Table 2. Test Conditions for Current Requirements

Parameter	Value Used
TEST CONDITION 1	
Number of HDMI Inputs (Xpressview Mode)	Two inputs
Xpressview	On
Video Format (Each HDMI Input)	4k × 2k
HDCP Decryption	Off
Video Pattern (Each HDMI Input)	SMPTE
Temperature	20°C
Power Supply Voltages	Nominal
TEST CONDITION 2	
Number of HDMI Inputs (Xpressview Mode)	Two inputs
Xpressview	On
Video Format (Each HDMI Input)	1080p60, 36 bits
HDCP Decryption	Off
Video Pattern (Each HDMI Input)	SMPTE
Temperature	20°C
Power Supply Voltages	Nominal
TEST CONDITION 3 (POWER-DOWN)	
Number of HDMI Inputs (Xpressview Mode)	N/A
Xpressview	N/A
Video Format (Each HDMI Input)	N/A
HDCP Decryption	N/A
Video Pattern (Each HDMI Input)	N/A
Temperature	20°C
Power Supply Voltages	Nominal
Other Test Parameters	Power-Down Mode 0 (IO map, Register 0x0C = 0x62) Ring oscillator powered down (HDMI map, Register 0x48 = 0x01) DDC pads powered off (HDMI map, Register 0x73 = 0x03) ¹

¹ For information about these registers, see the Hardware User Guide for the [ADV7619 \(UG-237\)](#).

DATA AND I²C TIMING CHARACTERISTICS

Table 3.

Parameter	Symbol	Test Conditions/Comments	Min	Typ	Max	Unit
CLOCK AND CRYSTAL						
Crystal Frequency, XTAL				28.63636		MHz
Crystal Frequency Stability					±50	ppm
LLC Frequency Range			13.5		170	MHz
I²C PORTS						
SCL Frequency					400	kHz
SCL Minimum Pulse Width High ¹	t ₁		600			ns
SCL Minimum Pulse Width Low ¹	t ₂		1.3			µs
Start Condition Hold Time ¹	t ₃		600			ns
Start Condition Setup Time ¹	t ₄		600			ns
SDA Setup Time ¹	t ₅		100			ns
SCL and SDA Rise Time ¹	t ₆				300	ns
SCL and SDA Fall Time ¹	t ₇				300	ns
Stop Condition Setup Time ¹	t ₈		0.6			µs
RESET FEATURE						
Reset Pulse Width			5			ms
CLOCK OUTPUTS^{1,2}						
LLC Mark-Space Ratio	t ₉ :t ₁₀	For input video resolutions with a pixel clock frequency ≤ 170 MHz	45:55		55:45	% duty cycle
		For input video resolutions with a pixel clock frequency > 170 MHz	40:60		60:40	% duty cycle
DATA AND CONTROL OUTPUTS^{1,2}						
Data Output Transition Time	t ₁₁ t ₁₂	End of valid data to negative LLC edge Negative LLC edge to start of valid data		1.0 0.1		ns ns
I²S PORT, MASTER MODE¹						
SCLK Mark-Space Ratio	t ₁₅ :t ₁₆		45:55		55:45	% duty cycle
LRCLK Data Transition Time	t ₁₇ t ₁₈	End of valid data to negative SCLK edge Negative SCLK edge to start of valid data			10 10	ns ns
I2Sx Data Transition Time	t ₁₉ t ₂₀	End of valid data to negative SCLK edge Negative SCLK edge to start of valid data			5 5	ns ns

¹ Data guaranteed by characterization.

² DLL bypassed on clock path.

Timing Diagrams

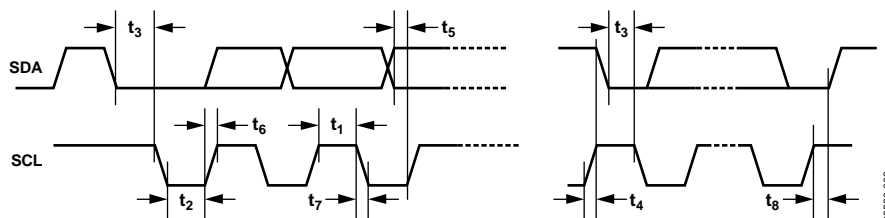

Figure 3. I²C Timing

09F560-003

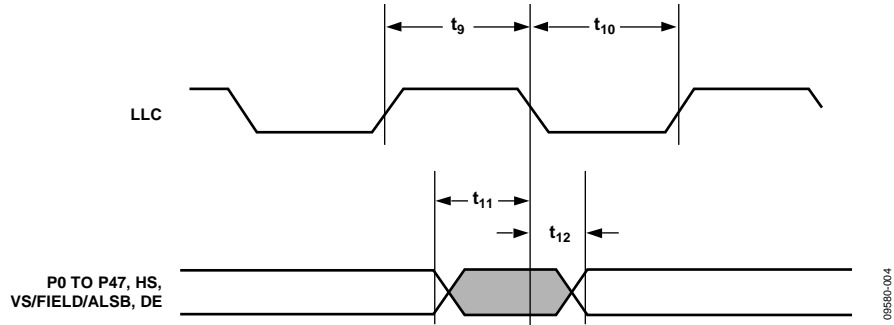
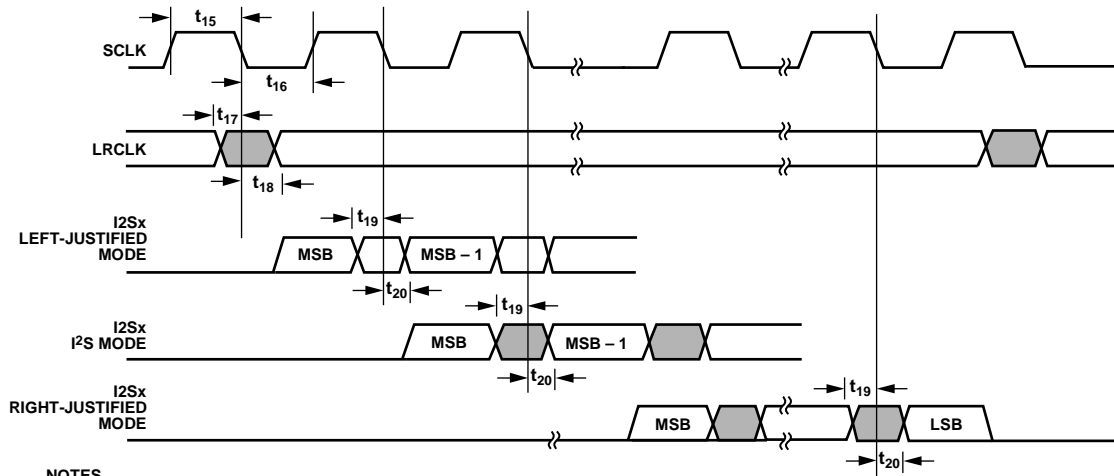

Figure 4. Pixel Port and Control SDR Output Timing

09580-004



- NOTES
1. THE LRCLK SIGNAL IS AVAILABLE ON THE AP5 PIN.
 2. I2Sx SIGNALS (WHERE x = 0, 1, 2, OR 3) ARE AVAILABLE ON THE FOLLOWING PINS: AP1, AP2, AP3, AND AP4.

Figure 5. I²S Timing

09580-005

ABSOLUTE MAXIMUM RATINGS

Table 4.

Parameter	Rating
DVDD to GND	2.2 V
PVDD to GND	2.2 V
DVDDIO to GND	4.0 V
CVDD to GND	2.2 V
TVDD to GND	4.0 V
Digital Inputs to GND	GND – 0.3 V to DVDDIO + 0.3 V
5 V Tolerant Digital Inputs to GND ¹	5.3 V
Digital Outputs to GND	GND – 0.3 V to DVDDIO + 0.3 V
XTALP, XTALN	–0.3 V to PVDD + 0.3 V
SCL, SDA Data Pins to DVDDIO	DVDDIO – 0.3 V to DVDDIO + 3.6 V
Maximum Junction Temperature (T _{JMAX})	125°C
Storage Temperature Range	–60°C to +150°C
Operating Temperature Range	0°C to 70°C
Infrared Reflow Soldering (20 sec)	260°C

¹ The following inputs are 3.3 V inputs but are 5 V tolerant: DDCA_SCL, DDCA_SDA, DDCB_SCL, and DDCB_SDA.

Stresses at or above those listed under Absolute Maximum Ratings may cause permanent damage to the product. This is a stress rating only; functional operation of the product at these or any other conditions above those indicated in the operational section of this specification is not implied. Operation beyond the maximum operating conditions for extended periods may affect product reliability.

PACKAGE THERMAL PERFORMANCE

To reduce power consumption when using the [ADV7619](#), the user is advised to turn off the unused sections of the part.

Due to PCB metal variation and, therefore, variation in PCB heat conductivity, the value of θ_{JA} may differ for various PCBs.

The most efficient measurement solution is obtained using the package surface temperature to estimate the die temperature because this solution eliminates the variance associated with the θ_{JA} value.

The maximum junction temperature (T_{JMAX}) of 125°C must not be exceeded. The following equation calculates the junction temperature using the measured package surface temperature and applies only when no heat sink is used on the device under test (DUT):

$$T_J = T_S + (\Psi_{JT} \times W_{TOTAL})$$

where:

T_S is the package surface temperature (°C).

$\Psi_{JT} = 0.22^\circ\text{C}/\text{W}$ for the 128-lead TQFP_EP.

$$W_{TOTAL} = ((PVDD \times I_{PVDD}) + (0.2 \times TVDD \times I_{TVDD}) + (CVDD \times I_{CVDD}) + (DVDD \times I_{DVDD}) + (DVDDIO \times I_{DVDDIO}))$$

where 0.2 is 20% of the TVDD power that is dissipated on the part itself.

ESD CAUTION



ESD (electrostatic discharge) sensitive device. Charged devices and circuit boards can discharge without detection. Although this product features patented or proprietary protection circuitry, damage may occur on devices subjected to high energy ESD. Therefore, proper ESD precautions should be taken to avoid performance degradation or loss of functionality.

PIN CONFIGURATION AND FUNCTION DESCRIPTIONS

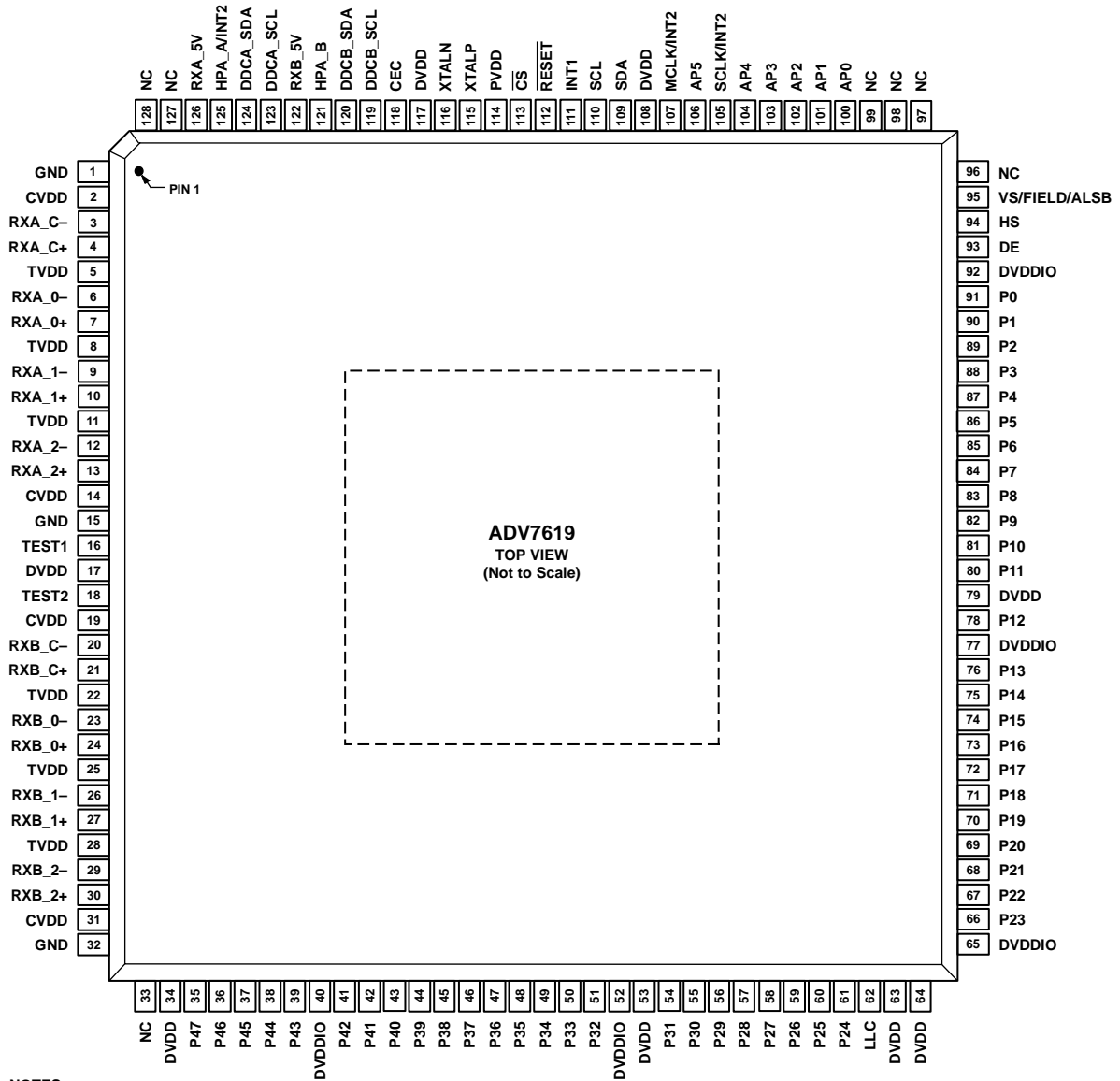

- NOTES**
1. NC = NO CONNECT. DO NOT CONNECT TO THIS PIN.
 2. CONNECT THE EXPOSED PAD (PIN 0) ON THE BOTTOM OF THE PACKAGE TO GROUND.

Figure 6. Pin Configuration

09580-008

Table 5. Pin Function Descriptions

Pin No.	Mnemonic	Type	Description
0	GND	Ground	Ground. Connect the exposed pad (Pin 0) on the bottom of the package to ground.
1	GND	Ground	Ground.
2	CVDD	Power	HDMI Analog Block Supply Voltage (1.8 V).
3	RXA_C-	HDMI input	Digital Input Clock Complement of Port A in the HDMI Interface.
4	RXA_C+	HDMI input	Digital Input Clock True of Port A in the HDMI Interface.
5	TVDD	Power	Terminator Supply Voltage (3.3 V).
6	RXA_0-	HDMI input	Digital Input Channel 0 Complement of Port A in the HDMI Interface.
7	RXA_0+	HDMI input	Digital Input Channel 0 True of Port A in the HDMI Interface.
8	TVDD	Power	Terminator Supply Voltage (3.3 V).
9	RXA_1-	HDMI input	Digital Input Channel 1 Complement of Port A in the HDMI Interface.
10	RXA_1+	HDMI input	Digital Input Channel 1 True of Port A in the HDMI Interface.
11	TVDD	Power	Terminator Supply Voltage (3.3 V).
12	RXA_2-	HDMI input	Digital Input Channel 2 Complement of Port A in the HDMI Interface.
13	RXA_2+	HDMI input	Digital Input Channel 2 True of Port A in the HDMI Interface.
14	CVDD	Power	HDMI Analog Block Supply Voltage (1.8 V).
15	GND	Ground	Ground.
16	TEST1	Test	This pin must be left floating.
17	DVDD	Power	Digital Core Supply Voltage (1.8 V).
18	TEST2	Test	This pin must be left floating.
19	CVDD	Power	HDMI Analog Block Supply Voltage (1.8 V).
20	RXB_C-	HDMI input	Digital Input Clock Complement of Port B in the HDMI Interface.
21	RXB_C+	HDMI input	Digital Input Clock True of Port B in the HDMI Interface.
22	TVDD	Power	Terminator Supply Voltage (3.3 V).
23	RXB_0-	HDMI input	Digital Input Channel 0 Complement of Port B in the HDMI Interface.
24	RXB_0+	HDMI input	Digital Input Channel 0 True of Port B in the HDMI Interface.
25	TVDD	Power	Terminator Supply Voltage (3.3 V).
26	RXB_1-	HDMI input	Digital Input Channel 1 Complement of Port B in the HDMI Interface.
27	RXB_1+	HDMI input	Digital Input Channel 1 True of Port B in the HDMI Interface.
28	TVDD	Power	Terminator Supply Voltage (3.3 V).
29	RXB_2-	HDMI input	Digital Input Channel 2 Complement of Port B in the HDMI Interface.
30	RXB_2+	HDMI input	Digital Input Channel 2 True of Port B in the HDMI Interface.
31	CVDD	Power	HDMI Analog Block Supply Voltage (1.8 V).
32	GND	Ground	Ground.
33	NC	No connect	No Connect. Do not connect to this pin.
34	DVDD	Power	Digital Core Supply Voltage (1.8 V).
35	P47	Digital video output	Video Pixel Output Port.
36	P46	Digital video output	Video Pixel Output Port.
37	P45	Digital video output	Video Pixel Output Port.
38	P44	Digital video output	Video Pixel Output Port.
39	P43	Digital video output	Video Pixel Output Port.
40	DVDDIO	Power	Digital I/O Supply Voltage (3.3 V).
41	P42	Digital video output	Video Pixel Output Port.
42	P41	Digital video output	Video Pixel Output Port.
43	P40	Digital video output	Video Pixel Output Port.
44	P39	Digital video output	Video Pixel Output Port.
45	P38	Digital video output	Video Pixel Output Port.
46	P37	Digital video output	Video Pixel Output Port.
47	P36	Digital video output	Video Pixel Output Port.
48	P35	Digital video output	Video Pixel Output Port.
49	P34	Digital video output	Video Pixel Output Port.
50	P33	Digital video output	Video Pixel Output Port.
51	P32	Digital video output	Video Pixel Output Port.

Pin No.	Mnemonic	Type	Description
52	DVDDIO	Power	Digital I/O Supply Voltage (3.3 V).
53	DVDD	Power	Digital Core Supply Voltage (1.8 V).
54	P31	Digital video output	Video Pixel Output Port.
55	P30	Digital video output	Video Pixel Output Port.
56	P29	Digital video output	Video Pixel Output Port.
57	P28	Digital video output	Video Pixel Output Port.
58	P27	Digital video output	Video Pixel Output Port.
59	P26	Digital video output	Video Pixel Output Port.
60	P25	Digital video output	Video Pixel Output Port.
61	P24	Digital video output	Video Pixel Output Port.
62	LLC	Digital video output	Pixel Output Clock for the Pixel Data. The range is from 13.5 MHz to 170 MHz.
63	DVDD	Power	Digital Core Supply Voltage (1.8 V).
64	DVDD	Power	Digital Core Supply Voltage (1.8 V).
65	DVDDIO	Power	Digital I/O Supply Voltage (3.3 V).
66	P23	Digital video output	Video Pixel Output Port.
67	P22	Digital video output	Video Pixel Output Port.
68	P21	Digital video output	Video Pixel Output Port.
69	P20	Digital video output	Video Pixel Output Port.
70	P19	Digital video output	Video Pixel Output Port.
71	P18	Digital video output	Video Pixel Output Port.
72	P17	Digital video output	Video Pixel Output Port.
73	P16	Digital video output	Video Pixel Output Port.
74	P15	Digital video output	Video Pixel Output Port.
75	P14	Digital video output	Video Pixel Output Port.
76	P13	Digital video output	Video Pixel Output Port.
77	DVDDIO	Power	Digital I/O Supply Voltage (3.3 V).
78	P12	Digital video output	Video Pixel Output Port.
79	DVDD	Power	Digital Core Supply Voltage (1.8 V).
80	P11	Digital video output	Video Pixel Output Port.
81	P10	Digital video output	Video Pixel Output Port.
82	P9	Digital video output	Video Pixel Output Port.
83	P8	Digital video output	Video Pixel Output Port.
84	P7	Digital video output	Video Pixel Output Port.
85	P6	Digital video output	Video Pixel Output Port.
86	P5	Digital video output	Video Pixel Output Port.
87	P4	Digital video output	Video Pixel Output Port.
88	P3	Digital video output	Video Pixel Output Port.
89	P2	Digital video output	Video Pixel Output Port.
90	P1	Digital video output	Video Pixel Output Port.
91	P0	Digital video output	Video Pixel Output Port.
92	DVDDIO	Power	Digital I/O Supply Voltage (3.3 V).
93	DE	Miscellaneous digital	Data Enable. The DE signal indicates active pixel data.
94	HS	Digital video output	Horizontal Synchronization Output Signal.
95	VS/FIELD/ALSB	Digital video output	VS is a vertical synchronization output signal. FIELD is a field synchronization output signal in all interlaced video modes. ALSB allows selection of the I ² C address.
96	NC	No connect	No Connect. Do not connect to this pin.
97	NC	No connect	No Connect. Do not connect to this pin.
98	NC	No connect	No Connect. Do not connect to this pin.
99	NC	No connect	No Connect. Do not connect to this pin.
100	AP0	Miscellaneous	Audio Output Pin. This pin can be configured to output S/PDIF digital audio, high bit rate (HBR), or Direct Stream Digital® (DSD®).
101	AP1	Miscellaneous	Audio Output Pin. This pin can be configured to output S/PDIF digital audio, high bit rate (HBR), Direct Stream Digital (DSD).

Pin No.	Mnemonic	Type	Description
102	AP2	Miscellaneous	Audio Output Pin. This pin can be configured to output S/PDIF digital audio, high bit rate (HBR), Direct Stream Digital (DSD), or I ² S.
103	AP3	Miscellaneous	Audio Output Pin. This pin can be configured to output S/PDIF digital audio, high bit rate (HBR), Direct Stream Digital (DSD), or I ² S.
104	AP4	Miscellaneous	Audio Output Pin. This pin can be configured to output S/PDIF digital audio, high bit rate (HBR), Direct Stream Digital (DSD), or I ² S.
105	SCLK/INT2	Miscellaneous digital	Serial Clock/Interrupt 2. This dual-function pin can be configured to output the audio serial clock or an Interrupt 2 signal.
106	AP5	Miscellaneous	Audio Output Pin. This pin can be configured to output S/PDIF digital audio, high bit rate (HBR), or Direct Stream Digital (DSD). Pin AP5 is typically used to provide the LRCLK for I ² S modes.
107	MCLK/INT2	Miscellaneous digital	Master Clock/Interrupt 2. This dual-function pin can be configured to output the audio master clock or an Interrupt 2 signal.
108	DVDD	Power	Digital Core Supply Voltage (1.8 V).
109	SDA	Miscellaneous digital	I ² C Port Serial Data Input/Output Pin. SDA is the data line for the control port.
110	SCL	Miscellaneous digital	I ² C Port Serial Clock Input. SCL is the clock line for the control port.
111	INT1	Miscellaneous digital	Interrupt. This pin can be active low or active high. When status bits change, this pin is triggered. The events that trigger an interrupt are user configurable.
112	$\overline{\text{RESET}}$	Miscellaneous digital	System Reset Input. Active low. A minimum low reset pulse width of 5 ms is required to reset the ADV7619 circuitry.
113	$\overline{\text{CS}}$	Miscellaneous digital	Chip Select. This pin has an internal pull-down. Pulling this line up causes I ² C state machine to ignore I ² C transmission.
114	PVDD	Power	PLL Supply Voltage (1.8 V).
115	XTALP	Miscellaneous	Input Pin for 28.63636 MHz Crystal or External 1.8 V, 28.63636 MHz Clock Oscillator Source to Clock the ADV7619 .
116	XTALN	Miscellaneous	Crystal Input. Input pin for 28.63636 MHz crystal.
117	DVDD	Power	Digital Core Supply Voltage (1.8 V).
118	CEC	Digital input/output	Consumer Electronics Control Channel.
119	DDCB_SCL	HDMI input	HDCP Slave Serial Clock Port B. DDCB_SCL is a 3.3 V input that is 5 V tolerant.
120	DDCB_SDA	HDMI input	HDCP Slave Serial Data Port B. DDCB_SDA is a 3.3 V input that is 5 V tolerant.
121	HPA_B	Miscellaneous digital	Hot Plug Assert Signal Output for HDMI Port B. This pin is 5 V tolerant.
122	RXB_5V	HDMI input	5 V Detect Pin for Port B in the HDMI Interface.
123	DDCA_SCL	HDMI input	HDCP Slave Serial Clock Port A. DDCA_SCL is a 3.3 V input that is 5 V tolerant.
124	DDCA_SDA	HDMI input	HDCP Slave Serial Data Port A. DDCA_SDA is a 3.3 V input that is 5 V tolerant.
125	HPA_A/INT2	Miscellaneous digital	Hot Plug Assert/Interrupt 2. This dual-function pin can be configured to output the Hot Plug assert signal for HDMI Port A or an Interrupt 2 signal. This pin is 5 V tolerant.
126	RXA_5V	HDMI input	5 V Detect Pin for Port A in the HDMI Interface.
127	NC	No connect	No Connect. Do not connect to this pin.
128	NC	No connect	No Connect. Do not connect to this pin.

POWER SUPPLY RECOMMENDATIONS

POWER-UP SEQUENCE

The recommended power-up sequence for the [ADV7619](#) is to power up the 3.3 V supplies first, followed by the 1.8 V supplies. $\overline{\text{RESET}}$ should be held low while the supplies are powered up.

Alternatively, the [ADV7619](#) can be powered up by asserting all supplies simultaneously. In this case, care must be taken while the supplies are being established to ensure that a lower rated supply does not go above a higher rated supply level.

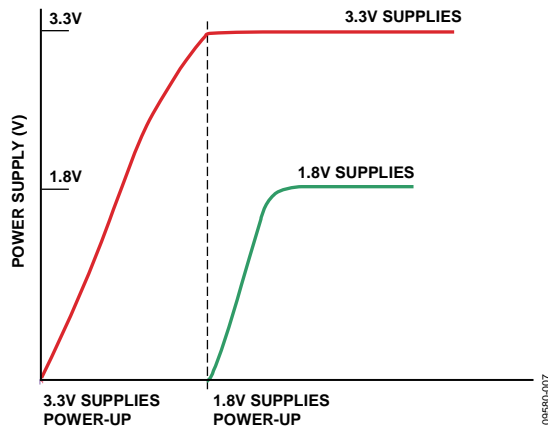

Figure 7. Recommended Power-Up Sequence

POWER-DOWN SEQUENCE

The [ADV7619](#) supplies can be deasserted simultaneously as long as a higher rated supply does not go below a lower rated supply.

CURRENT RATING REQUIREMENTS FOR POWER SUPPLY DESIGN

Table 6 shows the current rating requirements for power supply design.

Table 6. Current Rating Requirements for Power Supply Design

Parameter	Current Rating (mA)
$I_{D\text{VDD}}$	400
$I_{D\text{VDDIO}}$	300
$I_{P\text{VDD}}$	50
$I_{T\text{VDD}}$	120
$I_{C\text{VDD}}$	250

FUNCTIONAL OVERVIEW

HDMI RECEIVER

The HDMI receiver supports all mandatory and many optional 3D video formats defined in the HDMI 1.4a specification, HDTV formats up to 2160p, and all display resolutions up to 4k × 2k (3840 × 2160 at 30 Hz).

With the inclusion of HDCP, displays can now receive encrypted video content. The HDMI interface of the [ADV7619](#) allows for authentication of a video receiver, decryption of encoded data at the receiver, and renewability of that authentication during transmission, as specified by the HDCP 1.4 specification.

The HDMI-compatible receiver on the [ADV7619](#) allows active equalization of the HDMI data signals. This equalization compensates for the high frequency losses inherent in HDMI and DVI cabling, especially at longer cable lengths and higher frequencies. The HDMI-compatible receiver is capable of equalizing for cable lengths up to 30 meters to achieve robust receiver performance. The [ADV7619](#) also supports TERC4 error detection, which is used for detection of corrupted HDMI packets following a cable disconnect.

The HDMI receiver offers advanced audio functionality. The receiver contains an audio mute controller that can detect a variety of conditions that may result in audible extraneous noise in the audio output. Upon detection of these conditions, the audio signal can be ramped down or muted to prevent audio clicks or pops. The HDMI receiver supports the reception of all types of audio data described in the HDMI specifications, including

- LPCM (uncompressed audio)
- IEC 61937 (compressed audio)
- DSD audio (1-bit audio)
- HBR audio (high bit rate compressed audio)

Xpressview fast switching can be implemented with full HDCP authentication available on the background port. Synchronization measurement and status information are available for all HDMI inputs. HDMI receiver features include

- 2:1 multiplexed HDMI receiver
- 3D format support
- 297 MHz HDMI receiver
- Support for 4k × 2k resolutions
- Integrated equalizer for cable lengths up to 30 meters
- High-bandwidth Digital Content Protection (HDCP 1.4) (on background ports, also)
- Internal HDCP keys
- 36-/30-bit Deep Color support (resolutions up to 1080p)
- Audio sample, HBR, DSD packet support
- Repeater support
- Internal EDID RAM
- Hot Plug assert output pin for each HDMI port
- CEC controller

COMPONENT PROCESSOR (CP)

The [ADV7619](#) has two any-to-any, 3 × 3 color space conversion (CSC) matrices. The first CSC block is placed in front of the CP section. The second CSC block is placed at the back of the CP section. Each CSC enables YPrPb-to-RGB and RGB-to-YCrCb conversions. Many other standards of color space can be implemented using the color space converters.

The CP block is available only for video signals with resolution up to 1080p Deep Color (pixel rates up to 170 MHz). For resolutions higher than 1080p, the video signal bypasses the CP block and is routed directly to the pixel bus output as two 24-bit (4:4:4) buses running at up to 150 MHz.

CP features include

- Support for 525i, 625i, 525p, 625p, 720p, 1080i, 1080p, and many other HDTV formats
- Manual adjustments including gain (contrast), offset (brightness), hue, and saturation
- Free-run output mode that provides stable timing when no video input is present
- 170 MHz conversion rate, which supports RGB input resolutions up to 1600 × 1200 at 60 Hz
- Standard identification enabled by STDI block
- RGB that can be color space converted to YCrCb and decimated to a 4:2:2 format for video-centric, back-end IC interfacing
- Data enable (DE) output signal supplied for direct connection to HDMI/DVI transmitter

OTHER FEATURES

The [ADV7619](#) has HS, VS, FIELD, and DE output signals with programmable position, polarity, and width.

The [ADV7619](#) has two programmable interrupt request output pins: INT1 and INT2 (INT2 is accessible via one of the following pins: MCLK/INT2, SCLK/INT2, or HPA_A/INT2). The [ADV7619](#) also features a low power power-down mode.

The main I²C address can be set to 0x98 or 0x9A. On power-up or after a reset, the I²C address is set to 0x98 by default. The address can be changed to 0x9A by pulling up the VS/FIELD/ALSB pin and issuing the I²C command SAMPLE_ALSB. For more information, see the Register Access and Serial Ports Description section in the [UG-237](#).

The [ADV7619](#) is provided in a 128-lead, 14 mm × 14 mm, RoHS-compliant TQFP_EP package and is specified over the 0°C to 70°C temperature range.

PIXEL INPUT/OUTPUT FORMATTING

The output section of the [ADV7619](#) is highly flexible. The pixel output bus can support up to 36-bit 4:4:4 YCrCb or 36-bit 4:4:4 RGB. For resolutions higher than 1080p, the pixel output bus supports two 24-bit 4:4:4 RGB/YCrCb.

Part supports SDR (single data rate) and double data rate (DDR) outputs. SDR is supported up to 170 MHz LLC frequency (UXGA, 1080p60 for any OP_FORMAT_SEL or up to 300 MHz HDMI signals output on two 24-bit parallel video sub buses OP_FORMAT_SEL = 0x94, 0x95, 0x96, or 0x54; refer to Table 12). DDR can be supported with LLC clock frequency up to 50 MHz (video modes with original pixel clock lower than 100 MHz, such as 1080i60). In SDR mode, 16-/20-/24-bit 4:2:2 or 24-/30-/36-bit 4:4:4 output is possible. In DDR mode, the pixel output port can be configured for 4:2:2 YCrCb or 4:4:4 RGB for data rates up to 27 MHz.

Bus rotation is supported.

Table 7 through Table 12 provide the different output formats that are supported. All output modes are controlled via I²C.

For resolutions higher than 1080p, the video signals are routed directly to the pixel bus output as two 24-bit (4:4:4) buses running at up to 150 MHz. In this mode, the output data format is the same as the input format.

PIXEL DATA OUTPUT MODE FEATURES

For resolutions up to 1080p Deep Color, the output pixel port features include the following:

- SDR 8-/10-/12-bit ITU-R BT.656 4:2:2 YCrCb with embedded time codes and/or HS, VS, and FIELD output signals
- SDR 16-/20-/24-bit 4:2:2 YCrCb with embedded time codes and/or HS and VS/FIELD pin timing
- SDR 24-/30-/36-bit 4:4:4 YCrCb/RGB with embedded time codes and/or HS and VS/FIELD pin timing
- DDR 8-/10-/12-bit 4:2:2 YCrCb for data rates up to 27 MHz
- DDR 12-/24-/30-/36-bit 4:4:4 RGB for data rates up to 27 MHz

For resolutions greater than 1080p Deep Color (direct pass-through of video signal), the output pixel port features include the following:

- 8-bit 4:4:4 RGB/YCrCb for resolutions up to 2160p
- 12-bit 4:2:2 RGB/YCrCb for resolutions up to 2160p

Table 7. SDR 4:2:2 Output Modes (8-/10-/12-Bit)¹

Pixel Output	SDR 4:2:2—OP_FORMAT_SEL[7:0] =				
	0x00	0x01	0x02	0x06	0x0A
	8-Bit SDR ITU-R BT.656 Mode 0	10-Bit SDR ITU-R BT.656 Mode 0	12-Bit SDR ITU-R BT.656 Mode 0	12-Bit SDR ITU-R BT.656 Mode 1	12-Bit SDR ITU-R BT.656 Mode 2
P47	High-Z	High-Z	High-Z	High-Z	High-Z
P46	High-Z	High-Z	High-Z	High-Z	High-Z
P45	High-Z	High-Z	High-Z	High-Z	High-Z
P44	High-Z	High-Z	High-Z	High-Z	High-Z
P43	High-Z	High-Z	High-Z	High-Z	High-Z
P42	High-Z	High-Z	High-Z	High-Z	High-Z
P41	High-Z	High-Z	High-Z	High-Z	High-Z
P40	High-Z	High-Z	High-Z	High-Z	High-Z
P39	High-Z	High-Z	High-Z	High-Z	High-Z
P38	High-Z	High-Z	High-Z	High-Z	High-Z
P37	High-Z	High-Z	High-Z	High-Z	High-Z
P36	High-Z	High-Z	High-Z	High-Z	High-Z
P35	High-Z	High-Z	High-Z	High-Z	Y3, Cb3, Cr3
P34	High-Z	High-Z	High-Z	High-Z	Y2, Cb2, Cr2
P33	High-Z	High-Z	High-Z	High-Z	Y1, Cb1, Cr1
P32	High-Z	High-Z	High-Z	High-Z	Y0, Cb0, Cr0
P31	High-Z	High-Z	High-Z	High-Z	High-Z
P30	High-Z	High-Z	High-Z	High-Z	High-Z
P29	High-Z	High-Z	High-Z	Y1, Cb1, Cr1	High-Z
P28	High-Z	High-Z	High-Z	Y0, Cb0, Cr0	High-Z
P27	High-Z	High-Z	High-Z	High-Z	High-Z
P26	High-Z	High-Z	High-Z	High-Z	High-Z
P25	High-Z	High-Z	High-Z	High-Z	High-Z
P24	High-Z	High-Z	High-Z	High-Z	High-Z
P23	Y7, Cb7, Cr7	Y9, Cb9, Cr9	Y11, Cb11, Cr11	Y11, Cb11, Cr11	Y11, Cb11, Cr11
P22	Y6, Cb6, Cr6	Y8, Cb8, Cr8	Y10, Cb10, Cr10	Y10, Cb10, Cr10	Y10, Cb10, Cr10
P21	Y5, Cb5, Cr5	Y7, Cb7, Cr7	Y9, Cb9, Cr9	Y9, Cb9, Cr9	Y9, Cb9, Cr9
P20	Y4, Cb4, Cr4	Y6, Cb6, Cr6	Y8, Cb8, Cr8	Y8, Cb8, Cr8	Y8, Cb8, Cr8
P19	Y3, Cb3, Cr3	Y5, Cb5, Cr5	Y7, Cb7, Cr7	Y7, Cb7, Cr7	Y7, Cb7, Cr7
P18	Y2, Cb2, Cr2	Y4, Cb4, Cr4	Y6, Cb6, Cr6	Y6, Cb6, Cr6	Y6, Cb6, Cr6
P17	Y1, Cb1, Cr1	Y3, Cb3, Cr3	Y5, Cb5, Cr5	Y5, Cb5, Cr5	Y5, Cb5, Cr5
P16	Y0, Cb0, Cr0	Y2, Cb2, Cr2	Y4, Cb4, Cr4	Y4, Cb4, Cr4	Y4, Cb4, Cr4
P15	High-Z	Y1, Cb1, Cr1	Y3, Cb3, Cr3	Y3, Cb3, Cr3	High-Z
P14	High-Z	Y0, Cb0, Cr0	Y2, Cb2, Cr2	Y2, Cb2, Cr2	High-Z
P13	High-Z	High-Z	Y1, Cb1, Cr1	High-Z	High-Z
P12	High-Z	High-Z	Y0, Cb0, Cr0	High-Z	High-Z
P11	High-Z	High-Z	High-Z	High-Z	High-Z
P10	High-Z	High-Z	High-Z	High-Z	High-Z
P9	High-Z	High-Z	High-Z	High-Z	High-Z
P8	High-Z	High-Z	High-Z	High-Z	High-Z
P7	High-Z	High-Z	High-Z	High-Z	High-Z
P6	High-Z	High-Z	High-Z	High-Z	High-Z
P5	High-Z	High-Z	High-Z	High-Z	High-Z
P4	High-Z	High-Z	High-Z	High-Z	High-Z
P3	High-Z	High-Z	High-Z	High-Z	High-Z
P2	High-Z	High-Z	High-Z	High-Z	High-Z
P1	High-Z	High-Z	High-Z	High-Z	High-Z
P0	High-Z	High-Z	High-Z	High-Z	High-Z

¹ Modes require additional writes to IO map Register 0x19 (Bits[7:6] should be set to 2'b11) and IO map Register 0x33 (Bit[6] should be set to 1).

Table 8. SDR 4:2:2 Output Modes (16-/20-/24-Bit)

Pixel Output	SDR 4:2:2—OP_FORMAT_SEL[7:0] =				
	0x80	0x81	0x82	0x86	0x8A
	16-Bit SDR ITU-R BT.656 Mode 0	20-Bit SDR ITU-R BT.656 Mode 0	24-Bit SDR ITU-R BT.656 Mode 0	24-Bit SDR ITU-R BT.656 Mode 1	24-Bit SDR ITU-R BT.656 Mode 2
P47	High-Z	High-Z	High-Z	High-Z	High-Z
P46	High-Z	High-Z	High-Z	High-Z	High-Z
P45	High-Z	High-Z	High-Z	High-Z	High-Z
P44	High-Z	High-Z	High-Z	High-Z	High-Z
P43	High-Z	High-Z	High-Z	High-Z	High-Z
P42	High-Z	High-Z	High-Z	High-Z	High-Z
P41	High-Z	High-Z	High-Z	High-Z	High-Z
P40	High-Z	High-Z	High-Z	High-Z	High-Z
P39	High-Z	High-Z	High-Z	High-Z	High-Z
P38	High-Z	High-Z	High-Z	High-Z	High-Z
P37	High-Z	High-Z	High-Z	High-Z	High-Z
P36	High-Z	High-Z	High-Z	High-Z	High-Z
P35	High-Z	High-Z	High-Z	High-Z	Y3
P34	High-Z	High-Z	High-Z	High-Z	Y2
P33	High-Z	High-Z	High-Z	Cb1, Cr1	Y1
P32	High-Z	High-Z	High-Z	Cb0, Cr0	Y0
P31	High-Z	High-Z	High-Z	High-Z	Cb3, Cr3
P30	High-Z	High-Z	High-Z	High-Z	Cb2, Cr2
P29	High-Z	High-Z	High-Z	Y1	Cb1, Cr1
P28	High-Z	High-Z	High-Z	Y0	Cb0, Cr0
P27	High-Z	High-Z	High-Z	High-Z	High-Z
P26	High-Z	High-Z	High-Z	High-Z	High-Z
P25	High-Z	High-Z	High-Z	High-Z	High-Z
P24	High-Z	High-Z	High-Z	High-Z	High-Z
P23	Y7	Y9	Y11	Y11	Y11
P22	Y6	Y8	Y10	Y10	Y10
P21	Y5	Y7	Y9	Y9	Y9
P20	Y4	Y6	Y8	Y8	Y8
P19	Y3	Y5	Y7	Y7	Y7
P18	Y2	Y4	Y6	Y6	Y6
P17	Y1	Y3	Y5	Y5	Y5
P16	Y0	Y2	Y4	Y4	Y4
P15	High-Z	Y1	Y3	Y3	High-Z
P14	High-Z	Y0	Y2	Y2	High-Z
P13	High-Z	High-Z	Y1	High-Z	High-Z
P12	High-Z	High-Z	Y0	High-Z	High-Z
P11	Cb7, Cr7	Cb9, Cr9	Cb11, Cr11	Cb11, Cr11	Cb11, Cr11
P10	Cb6, Cr6	Cb8, Cr8	Cb10, Cr10	Cb10, Cr10	Cb10, Cr10
P9	Cb5, Cr5	Cb7, Cr7	Cb9, Cr9	Cb9, Cr9	Cb9, Cr9
P8	Cb4, Cr4	Cb6, Cr6	Cb8, Cr8	Cb8, Cr8	Cb8, Cr8
P7	Cb3, Cr3	Cb5, Cr5	Cb7, Cr7	Cb7, Cr7	Cb7, Cr7
P6	Cb2, Cr2	Cb4, Cr4	Cb6, Cr6	Cb6, Cr6	Cb6, Cr6
P5	Cb1, Cr1	Cb3, Cr3	Cb5, Cr5	Cb5, Cr5	Cb5, Cr5
P4	Cb0, Cr0	Cb2, Cr2	Cb4, Cr4	Cb4, Cr4	Cb4, Cr4
P3	High-Z	Cb1, Cr1	Cb3, Cr3	Cb3, Cr3	High-Z
P2	High-Z	Cb0, Cr0	Cb2, Cr2	Cb2, Cr2	High-Z
P1	High-Z	High-Z	Cb1, Cr1	High-Z	High-Z
P0	High-Z	High-Z	Cb0, Cr0	High-Z	High-Z

Table 9. SDR 4:4:4 Output Modes

Pixel Output	SDR 4:4:4—OP_FORMAT_SEL[7:0] =			
	0x40	0x41	0x42	0x46
	24-Bit SDR Mode 0	30-Bit SDR Mode 0	36-Bit SDR Mode 0	36-Bit SDR Mode 1
P47	High-Z	High-Z	High-Z	High-Z
P46	High-Z	High-Z	High-Z	High-Z
P45	High-Z	High-Z	High-Z	High-Z
P44	High-Z	High-Z	High-Z	High-Z
P43	High-Z	High-Z	High-Z	High-Z
P42	High-Z	High-Z	High-Z	High-Z
P41	High-Z	High-Z	High-Z	High-Z
P40	High-Z	High-Z	High-Z	High-Z
P39	High-Z	High-Z	High-Z	High-Z
P38	High-Z	High-Z	High-Z	High-Z
P37	High-Z	High-Z	High-Z	High-Z
P36	High-Z	High-Z	High-Z	High-Z
P35	R7	R9	R11	R9
P34	R6	R8	R10	R8
P33	R5	R7	R9	R7
P32	R4	R6	R8	R6
P31	R3	R5	R7	R5
P30	R2	R4	R6	R4
P29	R1	R3	R5	R3
P28	R0	R2	R4	R2
P27	High-Z	R1	R3	R1
P26	High-Z	R0	R2	R0
P25	High-Z	High-Z	R1	G7
P24	High-Z	High-Z	R0	G6
P23	G7	G9	G11	G5
P22	G6	G8	G10	G4
P21	G5	G7	G9	G3
P20	G4	G6	G8	G2
P19	G3	G5	G7	G1
P18	G2	G4	G6	G0
P17	G1	G3	G5	B11
P16	G0	G2	G4	B10
P15	High-Z	G1	G3	B9
P14	High-Z	G0	G2	B8
P13	High-Z	High-Z	G1	G11
P12	High-Z	High-Z	G0	G10
P11	B7	B9	B11	B7
P10	B6	B8	B10	B6
P9	B5	B7	B9	B5
P8	B4	B6	B8	B4
P7	B3	B5	B7	B3
P6	B2	B4	B6	B2
P5	B1	B3	B5	B1
P4	B0	B2	B4	B0
P3	High-Z	B1	B3	R11
P2	High-Z	B0	B2	R10
P1	High-Z	High-Z	B1	G9
P0	High-Z	High-Z	B0	G8

Table 10. DDR 4:2:2 Output Modes

Pixel Output	DDR 4:2:2 Mode (Clock/2)—OP_FORMAT_SEL[7:0] =					
	0x20		0x21		0x22	
	8-Bit DDR ITU-R BT.656, Mode 0		10-Bit DDR ITU-R BT.656, Mode 0		12-Bit DDR ITU-R BT.656, Mode 0	
	Clock Rise	Clock Fall	Clock Rise	Clock Fall	Clock Rise	Clock Fall
P47	High-Z	High-Z	High-Z	High-Z	High-Z	High-Z
P46	High-Z	High-Z	High-Z	High-Z	High-Z	High-Z
P45	High-Z	High-Z	High-Z	High-Z	High-Z	High-Z
P44	High-Z	High-Z	High-Z	High-Z	High-Z	High-Z
P43	High-Z	High-Z	High-Z	High-Z	High-Z	High-Z
P42	High-Z	High-Z	High-Z	High-Z	High-Z	High-Z
P41	High-Z	High-Z	High-Z	High-Z	High-Z	High-Z
P40	High-Z	High-Z	High-Z	High-Z	High-Z	High-Z
P39	High-Z	High-Z	High-Z	High-Z	High-Z	High-Z
P38	High-Z	High-Z	High-Z	High-Z	High-Z	High-Z
P37	High-Z	High-Z	High-Z	High-Z	High-Z	High-Z
P36	High-Z	High-Z	High-Z	High-Z	High-Z	High-Z
P35	High-Z	High-Z	High-Z	High-Z	High-Z	High-Z
P34	High-Z	High-Z	High-Z	High-Z	High-Z	High-Z
P33	High-Z	High-Z	High-Z	High-Z	High-Z	High-Z
P32	High-Z	High-Z	High-Z	High-Z	High-Z	High-Z
P31	High-Z	High-Z	High-Z	High-Z	High-Z	High-Z
P30	High-Z	High-Z	High-Z	High-Z	High-Z	High-Z
P29	High-Z	High-Z	High-Z	High-Z	High-Z	High-Z
P28	High-Z	High-Z	High-Z	High-Z	High-Z	High-Z
P27	High-Z	High-Z	High-Z	High-Z	High-Z	High-Z
P26	High-Z	High-Z	High-Z	High-Z	High-Z	High-Z
P25	High-Z	High-Z	High-Z	High-Z	High-Z	High-Z
P24	High-Z	High-Z	High-Z	High-Z	High-Z	High-Z
P23	Cb7, Cr7	Y7	Cb9, Cr9	Y9	Cb11, Cr11	Y11
P22	Cb6, Cr6	Y6	Cb8, Cr8	Y8	Cb10, Cr10	Y10
P21	Cb5, Cr5	Y5	Cb7, Cr7	Y7	Cb9, Cr9	Y9
P20	Cb4, Cr4	Y4	Cb6, Cr6	Y6	Cb8, Cr8	Y8
P19	Cb3, Cr3	Y3	Cb5, Cr5	Y5	Cb7, Cr7	Y7
P18	Cb2, Cr2	Y2	Cb4, Cr4	Y4	Cb6, Cr6	Y6
P17	Cb1, Cr1	Y1	Cb3, Cr3	Y3	Cb5, Cr5	Y5
P16	Cb0, Cr0	Y0	Cb2, Cr2	Y2	Cb4, Cr4	Y4
P15	High-Z	High-Z	Cb1, Cr1	Y1	Cb3, Cr3	Y3
P14	High-Z	High-Z	Cb0, Cr0	Y0	Cb2, Cr2	Y2
P13	High-Z	High-Z	High-Z	High-Z	Cb1, Cr1	Y1
P12	High-Z	High-Z	High-Z	High-Z	Cb0, Cr0	Y0
P11	High-Z	High-Z	High-Z	High-Z	High-Z	High-Z
P10	High-Z	High-Z	High-Z	High-Z	High-Z	High-Z
P9	High-Z	High-Z	High-Z	High-Z	High-Z	High-Z
P8	High-Z	High-Z	High-Z	High-Z	High-Z	High-Z
P7	High-Z	High-Z	High-Z	High-Z	High-Z	High-Z
P6	High-Z	High-Z	High-Z	High-Z	High-Z	High-Z
P5	High-Z	High-Z	High-Z	High-Z	High-Z	High-Z
P4	High-Z	High-Z	High-Z	High-Z	High-Z	High-Z
P3	High-Z	High-Z	High-Z	High-Z	High-Z	High-Z
P2	High-Z	High-Z	High-Z	High-Z	High-Z	High-Z
P1	High-Z	High-Z	High-Z	High-Z	High-Z	High-Z
P0	High-Z	High-Z	High-Z	High-Z	High-Z	High-Z

Table 11. DDR 4:4:4 Output Modes

Pixel Output	DDR 4:4:4 Mode (Clock/2)—OP_FORMAT_SEL[7:0] =					
	0x60		0x61		0x62	
	24-Bit DDR, Mode 0		30-Bit DDR, Mode 0		36-Bit DDR, Mode 0	
	Clock Rise ¹	Clock Fall ¹	Clock Rise ¹	Clock Fall ¹	Clock Rise ¹	Clock Fall ¹
P47	High-Z	High-Z	High-Z	High-Z	High-Z	High-Z
P46	High-Z	High-Z	High-Z	High-Z	High-Z	High-Z
P45	High-Z	High-Z	High-Z	High-Z	High-Z	High-Z
P44	High-Z	High-Z	High-Z	High-Z	High-Z	High-Z
P43	High-Z	High-Z	High-Z	High-Z	High-Z	High-Z
P42	High-Z	High-Z	High-Z	High-Z	High-Z	High-Z
P41	High-Z	High-Z	High-Z	High-Z	High-Z	High-Z
P40	High-Z	High-Z	High-Z	High-Z	High-Z	High-Z
P39	High-Z	High-Z	High-Z	High-Z	High-Z	High-Z
P38	High-Z	High-Z	High-Z	High-Z	High-Z	High-Z
P37	High-Z	High-Z	High-Z	High-Z	High-Z	High-Z
P36	High-Z	High-Z	High-Z	High-Z	High-Z	High-Z
P35	R7-0	R7-1	R9-0	R9-1	R11-0	R11-1
P34	R6-0	R6-1	R8-0	R8-1	R10-0	R10-1
P33	R5-0	R5-1	R7-0	R7-1	R9-0	R9-1
P32	R4-0	R4-1	R6-0	R6-1	R8-0	R8-1
P31	R3-0	R3-1	R5-0	R5-1	R7-0	R7-1
P30	R2-0	R2-1	R4-0	R4-1	R6-0	R6-1
P29	R1-0	R1-1	R3-0	R3-1	R5-0	R5-1
P28	R0-0	R0-1	R2-0	R2-1	R4-0	R4-1
P27	High-Z	High-Z	R1-0	R1-1	R3-0	R3-1
P26	High-Z	High-Z	R0-0	R0-1	R2-0	R2-1
P25	High-Z	High-Z	High-Z	High-Z	R1-0	R1-1
P24	High-Z	High-Z	High-Z	High-Z	R0-0	R0-1
P23	G7-0	G7-1	G9-0	G9-1	G11-0	G11-1
P22	G6-0	G6-1	G8-0	G8-1	G10-0	G10-1
P21	G5-0	G5-1	G7-0	G7-1	G9-0	G9-1
P20	G4-0	G4-1	G6-0	G6-1	G8-0	G8-1
P19	G3-0	G3-1	G5-0	G5-1	G7-0	G7-1
P18	G2-0	G2-1	G4-0	G4-1	G6-0	G6-1
P17	G1-0	G1-1	G3-0	G3-1	G5-0	G5-1
P16	G0-0	G0-1	G2-0	G2-1	G4-0	G4-1
P15	High-Z	High-Z	G1-0	G1-1	G3-0	G3-1
P14	High-Z	High-Z	G0-0	G0-1	G2-0	G2-1
P13	High-Z	High-Z	High-Z	High-Z	G1-0	G1-1
P12	High-Z	High-Z	High-Z	High-Z	G0-0	G0-1
P11	B7-0	B7-1	B9-0	B9-1	B11-0	B11-1
P10	B6-0	B6-1	B8-0	B8-1	B10-0	B10-1
P9	B5-0	B5-1	B7-0	B7-1	B9-0	B9-1
P8	B4-0	B4-1	B6-0	B6-1	B8-0	B8-1
P7	B3-0	B3-1	B5-0	B5-1	B7-0	B7-1
P6	B2-0	B2-1	B4-0	B4-1	B6-0	B6-1
P5	B1-0	B1-1	B3-0	B3-1	B5-0	B5-1
P4	B0-0	B0-1	B2-0	B2-1	B4-0	B4-1
P3	High-Z	High-Z	B1-0	B1-1	B3-0	B3-1
P2	High-Z	High-Z	B0-0	B0-1	B2-0	B2-1
P1	High-Z	High-Z	High-Z	High-Z	B1-0	B1-1
P0	High-Z	High-Z	High-Z	High-Z	B0-0	B0-1

¹ xx-0 and xxx-0 correspond to data clocked at the rising edge; xx-1 and xxx-1 correspond to data clocked at the falling edge.

Table 12. Special SDR 4:2:2 and 4:4:4 Output Modes for Video with Pixel Clock Frequencies Above 170 MHz¹

Pixel Output	2 × SDR 4:2:2 Interleaved—OP_FORMAT_SEL[7:0] =			2 × SDR 4:4:4 Interleaved—OP_FORMAT_SEL[7:0] =
	0x94	0x95	0x96	0x54
	2 × 16-Bit Mode 0 ²	2 × 20-Bit Mode 0 ²	2 × 24-Bit Mode 0 ²	2 × 24-Bit Mode 0 ²
P47	Y7-0	Y9-0	Y11-0	G7-0
P46	Y6-0	Y8-0	Y10-0	G6-0
P45	Y5-0	Y7-0	Y9-0	G5-0
P44	Y4-0	Y6-0	Y8-0	G4-0
P43	Y3-0	Y5-0	Y7-0	G3-0
P42	Y2-0	Y4-0	Y6-0	G2-0
P41	Y1-0	Y3-0	Y5-0	G1-0
P40	Y0-0	Y2-0	Y4-0	G0-0
P39	High-Z	Y1-0	Y3-0	B7-0
P38	High-Z	Y0-0	Y2-0	B6-0
P37	High-Z	High-Z	Y1-0	B5-0
P36	High-Z	High-Z	Y0-0	B4-0
P35	Cb7-0	Cb9-0	Cb11-0	B3-0
P34	Cb6-0	Cb8-0	Cb10-0	B2-0
P33	Cb5-0	Cb7-0	Cb9-0	B1-0
P32	Cb4-0	Cb6-0	Cb8-0	B0-0
P31	Cb3-0	Cb5-0	Cb7-0	R7-0
P30	Cb2-0	Cb4-0	Cb6-0	R6-0
P29	Cb1-0	Cb3-0	Cb5-0	R5-0
P28	Cb0-0	Cb2-0	Cb4-0	R4-0
P27	High-Z	Cb1-0	Cb3-0	R3-0
P26	High-Z	Cb0-0	Cb2-0	R2-0
P25	High-Z	High-Z	Cb1-0	R1-0
P24	High-Z	High-Z	Cb0-0	R0-0
P23	Y7-1	Y9-1	Y11-1	G7-1
P22	Y6-1	Y8-1	Y10-1	G6-1
P21	Y5-1	Y7-1	Y9-1	G5-1
P20	Y4-1	Y6-1	Y8-1	G4-1
P19	Y3-1	Y5-1	Y7-1	G3-1
P18	Y2-1	Y4-1	Y6-1	G2-1
P17	Y1-1	Y3-1	Y5-1	G1-1
P16	Y0-1	Y2-1	Y4-1	G0-1
P15	High-Z	Y1-1	Y3-1	B7-1
P14	High-Z	Y0-1	Y2-1	B6-1
P13	High-Z	High-Z	Y1-1	B5-1
P12	High-Z	High-Z	Y0-1	B4-1
P11	Cr7-0	Cr9-0	Cr11-0	B3-1
P10	Cr6-0	Cr8-0	Cr10-0	B2-1
P9	Cr5-0	Cr7-0	Cr9-0	B1-1
P8	Cr4-0	Cr6-0	Cr8-0	B0-1
P7	Cr3-0	Cr5-0	Cr7-0	R7-1
P6	Cr2-0	Cr4-0	Cr6-0	R6-1
P5	Cr1-0	Cr3-0	Cr5-0	R5-1
P4	Cr0-0	Cr2-0	Cr4-0	R4-1
P3	High-Z	Cr1-0	Cr3-0	R3-1
P2	High-Z	Cr0-0	Cr2-0	R2-1
P1	High-Z	High-Z	Cr1-0	R1-1
P0	High-Z	High-Z	Cr0-0	R0-1

¹ These modes require additional writes. (write 80 to DPLL map Register 0xC3, write 03 to DPLL map Register 0xCF, and write A0 to IO map Register 0xDD). Refer to Hardware User Guide UG-237.

² xx-0 and xxx-0 correspond to odd samples; xx-1 and xxx-1 correspond to even samples.

OUTLINE DIMENSIONS

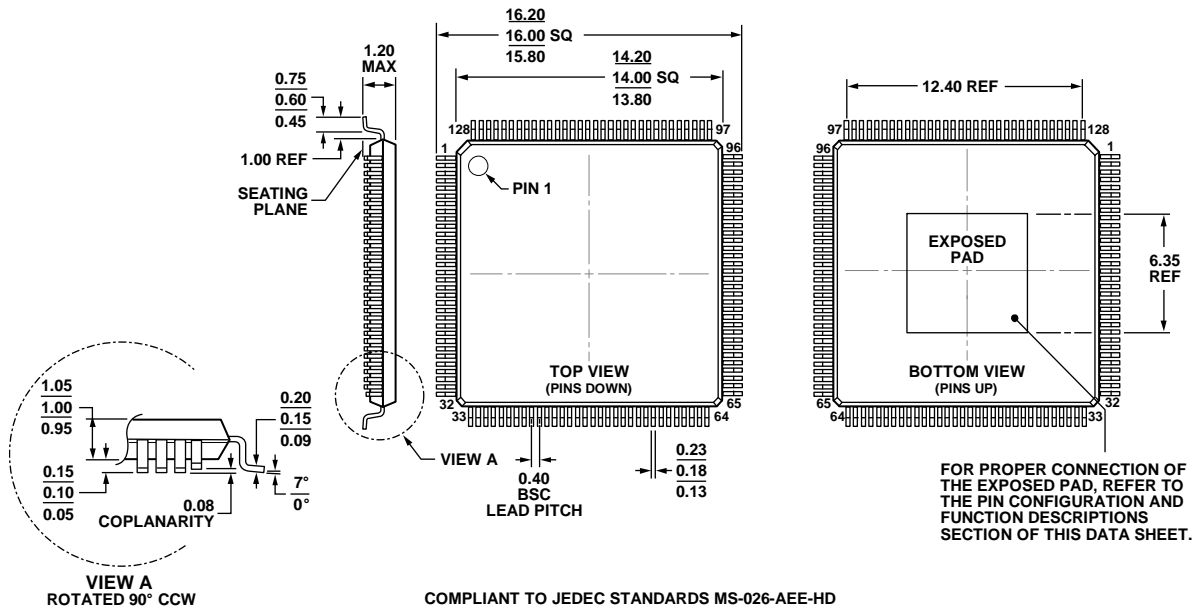

COMPLIANT TO JEDEC STANDARDS MS-026-AEE-HD
 Figure 8. 128-Lead Thin Quad Flat Package, Exposed Pad [TQFP_EP]
 (SV-128-1)
 Dimensions shown in millimeters

10-06-2011-A

ORDERING GUIDE

Model ^{1,2}	Temperature Range	Package Description	Package Option
ADV7619KSVZ	0°C to 70°C	128-Lead Thin Quad Flat Package, Exposed Pad [TQFP_EP]	SV-128-1
ADV7619KSVZ-P	0°C to 70°C	128-Lead Thin Quad Flat Package, Exposed Pad [TQFP_EP]	SV-128-1
EVAL-ADV7619-7511-P		Evaluation Board Without HDCP Keys	
EVAL-ADV7619-7511		Evaluation Board with HDCP Keys	

¹ Z = RoHS Compliant Part.

² EVAL-ADV7619-7511 and EVAL-ADV7619-7511-P are RoHS Compliant Parts.

NOTES

NOTES

I²C refers to a communications protocol originally developed by Philips Semiconductors (now NXP Semiconductors).
HDMI, the HDMI Logo, and High-Definition Multimedia Interface are trademarks or registered trademarks of HDMI Licensing LLC in the United States and other countries.