

FEATURES

High precision ADCs

- Dual channel, simultaneous sampling, 16-bit, Σ - Δ ADCs
- Programmable ADC throughput from 1 Hz to 8 kHz
- On-chip 5 ppm/ $^{\circ}$ C voltage reference

Current channel

- Fully differential, buffered input
- Programmable gain from 1 to 512
- ADC input range: -200 mV to +300 mV
- Digital comparators, with current accumulator feature

Voltage channel

- Buffered, on-chip attenuator for 12 V battery inputs

Temperature channel

- External and on-chip temperature sensor options

Microcontroller

- ARM7TDMI[®] core, 16-/32-bit RISC architecture
- 20.48 MHz PLL with programmable divider
- PLL input source
 - On-chip precision oscillator
 - On-chip low power oscillator
 - External (32.768 kHz) watch crystal

JTAG port supports code download and debug

Memory

- 32-kB Flash/EE memory, 4-kB SRAM
- 10,000-cycle Flash/EE endurance, 20-year Flash/EE retention
- In-circuit download via JTAG and LIN

On-chip peripherals

- LIN 2.0-compatible (slave) support via UART with hardware synchronization
- Flexible wake-up I/O pin, master/slave SPI[®] serial I/O
- 9-pin GPIO port, 3 \times general-purpose timers
- Wake-up and watchdog timers
- Power supply monitor, on-chip power-on-reset

Power

- Operates directly from 12 V battery supply

Current consumption

- Normal mode 10 mA at 10 MHz
- Low power monitor mode

Package and temperature range

- 48-lead, 7 mm \times 7 mm LFCSP
- Fully specified for -40 $^{\circ}$ C to +115 $^{\circ}$ C operation

APPLICATIONS

Battery sensing/management for automotive systems

FUNCTIONAL BLOCK DIAGRAM

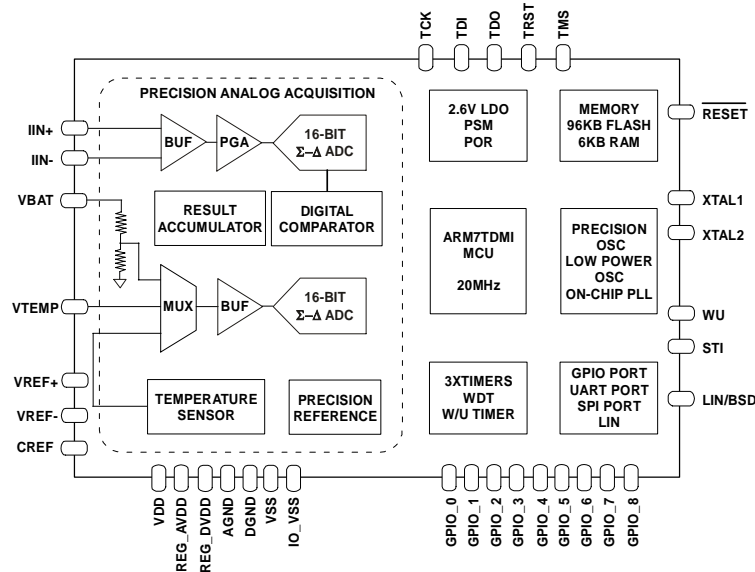

Figure 1.

Rev. Pr.A

Information furnished by Analog Devices is believed to be accurate and reliable. However, no responsibility is assumed by Analog Devices for its use, nor for any infringements of patents or other rights of third parties that may result from its use. Specifications subject to change without notice. No license is granted by implication or otherwise under any patent or patent rights of Analog Devices. Trademarks and registered trademarks are the property of their respective owners.

TABLE OF CONTENTS

Features	1	JTAG Access.....	28
Applications.....	1	ADuC7034 Flash/EE Memory	28
Functional Block Diagram	1	Flash/EE Control Interface	28
Specifications.....	6	FEE0CON Register	29
Electrical Specifications.....	6	Command Sequence for Executing a Mass Erase.....	30
Timing Specifications	11	FEE0STA Register	30
SPI Timing Specifications	11	FEE0MOD Register	31
LIN Timing Specifications	16	FEE0ADR Registers	31
Absolute Maximum Ratings.....	17	FEE0DAT Registers.....	31
ESD Caution.....	17	Flash/EE Memory Security	32
Pin Configuration and Function Descriptions.....	18	Flash/EE Memory Protection Registers	32
Typical Performance Characteristics	21	Temporary Protection	33
Terminology	22	Keyed Permanent Protection.....	33
Theory of Operation	23	Permanent Protection.....	33
Overview of the ARM7TDMI Core.....	23	Flash/EE Memory Reliability.....	33
Thumb Mode (T)	23	CODE Execution time from SRAM and Flash/EE	34
Multiplier (M).....	23	Execution from SRAM	34
EmbeddedICE (I).....	23	Execution from Flash/EE	34
ARM7 Exceptions	24	ADuC7034 Kernel.....	35
ARM Registers.....	24	Memory Mapped Registers	37
Interrupt Latency.....	24	Complete MMR Listing.....	38
Memory Organization	25	16-Bit, Σ - Δ Analog-to-Digital Converters.....	43
Memory Format	25	Current Channel ADC (I-ADC).....	43
SRAM.....	25	Voltage/Temperature Channel ADC (V/T-ADC)	45
Remap	25	ADC Ground Switch.....	46
Remap Operation	25	ADC Noise Performance Tables.....	47
SYSMAP0 Register	26	ADC MMR Interface	48
Reset	27	ADC Status Register	48
RSTSTA Register	27	ADC Interrupt Mask Register	49
RSTCLR Register.....	27	ADC Mode Register.....	49
Flash/EE Memory.....	28	Current Channel ADC Control Register	50
Serial Downloading (In-Circuit Programming)	28	Voltage/Temperature Channel ADC Control Register	52

ADC Filter Register	53	Current ADC Diagnostics	65
ADC Configuration Register.....	55	Voltage/Temperature ADC Diagnostics	65
Current Channel ADC Data Register	56	Power Supply Support Circuits	66
Voltage Channel ADC Data Register	56	ADuC7034 System Clocks	67
Temperature Channel ADC Data Register	56	PLLSTA Register	68
Current Channel ADC Offset Calibration Register	56	PLLCON Prewrite Key PLLKEY0	69
Voltage Channel ADC Offset Calibration Register	57	PLLCON Postwrite Key PLLKEY1.....	69
Temperature Channel ADC Offset Calibration Register..	57	PLLCON Register	69
Current Channel ADC Gain Calibration Register	57	POWCON Prewrite Key POWKEY0.....	69
Voltage Channel Gain Calibration Register	58	POWCON Postwrite Key POWKEY1	70
Temperature Channel Gain Calibration Register	58	POWCON Register	70
Current Channel ADC Result Counter Limit Register.....	58	Low Power Clock Calibration	71
Current Channel ADC Result Count Register.....	58	OSC0TRM Register	72
Current Channel ADC Threshold Register.....	59	OSC0CON Register	72
Current Channel ADC Threshold Count Limit Register..	59	OSC0STA Register.....	73
Current Channel ADC Threshold Count Register.....	59	OSC0VAL0 Register	73
Current Channel ADC Accumulator Register.....	59	OSC0VAL1 Register	73
Low Power Voltage Reference Scaling Factor	60	Processor Reference Peripherals	74
ADC Power Modes of Operation.....	60	Interrupt System.....	74
ADC Startup Procedure	60	IRQ.....	75
ADC Normal Power Mode	60	Fast Interrupt Request (FIQ).....	75
ADC Low Power Mode	60	Timers.....	76
ADC Low Power Plus Mode.....	61	Timer0—Lifetime Timer.....	77
Again, all of the ADC peripheral functions (result counter, digital comparator, and accumulator) described in the ADC Startup Procedure	61	Timer0 Value Registers (T0VAL0/T0VAL1)	77
ADC Comparator and Accumulator	61	Timer0 Capture Register.....	77
ADC Sinc3 Digital Filter Response	61	Timer0 Control Register	78
ADC Calibration	63	Timer0 Load Registers	79
Self-Calibration	64	Timer0 Clear Register	79
System Calibration.....	64	Timer1	80
Using the Offset and Gain Calibration	64	Timer1 Load Registers	80
Understanding the Offset and Gain Calibration Registers	64	Timer1 Clear Register	80
ADC Diagnostics	65	Timer1 Value Register.....	80
		Timer1 Capture Register.....	81

Timer1 Control Register	81	High Voltage Interface Control Register.....	100
Timer2 or Wake-Up Timer	82	High Voltage Data Register.....	101
Timer2 Load Registers.....	82	High Voltage Configuration0 Register	102
Timer2 Clear Register.....	82	High Voltage Configuration1 Register	103
Timer2 Value Register	82	High Voltage Monitor Register	104
Timer2 Control Register	83	High Voltage Status Register.....	105
Timer3 or Watchdog Timer	84	Wake UP (WU)	106
Normal Mode.....	84	Wake-Up (WU) Pin Circuit Description.....	106
Watchdog Mode	84	Handling Interrupts from the High Voltage Peripheral Control Interface	107
Timer3 Load Register	84	Low Voltage Flag (LVF).....	107
Timer3 Value Register	84	High Voltage Diagnostics.....	107
Timer3 Clear Register.....	84	UART Serial Interface.....	108
Timer3 Control Register	85	Baud Rate Generation.....	108
Timer4 or STI Timer.....	86	Normal 450 UART Baud Rate Generation	108
Timer4 Load Registers.....	86	ADuC7034 Fractional Divider	108
Timer4 Clear Register.....	86	UART Register Definition.....	108
Timer4 Value Register	86	UART TX Register	109
Timer4 Capture Register.....	86	UART RX Register	109
Timer4 Control Register	86	UART Divisor Latch Register 0.....	109
General-Purpose I/O	88	UART Divisor Latch Register 1	109
GPIO Port0 Control Register	90	UART Control Register 0	110
GPIO Port1 Control Register	91	UART Control Register 1	111
GPIO Port2 Control Register	91	UART Status Register 0	111
GPIO Port0 Data Register	93	UART Interrupt Enable Register 0.....	112
GPIO Port1 Data Register.....	94	UART Interrupt Identification Register 0.....	112
GPIO Port2 Data Register.....	95	UART Fractional Divider Register.....	113
GPIO Port0 Set Register	96	Serial Peripheral Interface.....	114
GPIO Port1 Set Register	96	MISO (Master In, Slave Out Data I/O Pin)	114
GPIO Port2 Set Register	97	MOSI (Master Out, Slave In Pin).....	114
GPIO Port0 Clear Register.....	97	SCLK (Serial Clock I/O Pin).....	114
GPIO Port1 Clear Register.....	98	Chip Select (\overline{SS}) Input Pin.....	114
GPIO Port2 Clear Register.....	98	SPI Register Definitions	114
High Voltage Peripheral Control Interface	99		

SPI Control Register	115	LIN Frame Data Byte	127
SPI Status Register	116	LIN Frame Data Transmission and Reception	127
SPI Receive Register.....	116	Example LIN Hardware Synchronization Routine	129
SPI Transmit Register	117	LIN Diagnostics	130
SPI Divider Register.....	117	LIN Operation During Thermal Shutdown.....	130
Serial Test Interface	118	Bit Serial Device (BSD) Interface.....	131
Serial Test Interface Key0 Register	118	BSD Communication Hardware Interface	131
Serial Test Interface Key1 Register	118	BSD Related MMRs	132
Serial Test Interface Data0 Register	118	LIN Hardware Synchronization Capture Register	132
Serial Test Interface Data1 Register	119	LIN Hardware Synchronization Compare Register	132
Serial Test Interface Data2 Register	119	BSD Communications Frame	133
Serial Test Interface Control Register.....	119	BSD Example Pulse Widths.....	133
Serial Test Interface Output Structure	120	Typical BSD Program Flow	133
Using the Serial Test Interface.....	120	BSD Data Reception	134
LIN (Local Interconnect Network) Interface	122	BSD Data Transmission	134
LIN MMR Description.....	122	Wake-Up from BSD Interface	134
LIN Hardware Synchronization Status Register	123	Part Identification	135
LIN Hardware Synchronization Control Register 0.....	124	System Serial ID Register 0.....	135
LIN Hardware Synchronization Control Register 1	126	System Serial ID Register 1.....	135
LIN Hardware Synchronization Timer0 Register.....	126	System Assembly Lot ID	136
LIN Hardware Break Timer1 Register	126	System Kernel Checksum	136
LIN Hardware Interface	127	System Identification FEE0ADR	137
LIN Frame Protocol.....	127	Schematic	138
LIN Frame Break Symbol	127	Outline Dimensions.....	139
LIN Frame Synchronization Byte	127	Ordering Guide	139
LIN Frame Protected Identifier.....	127		

SPECIFICATIONS

ELECTRICAL SPECIFICATIONS

$V_{DD} = 3.5\text{ V to }18\text{ V}$, $V_{REF} = 1.2\text{ V}$ internal reference, $f_{CORE} = 10.24\text{ MHz}$ driven from external 32.768 kHz watch crystal or on-chip precision oscillator, all specifications $T_A = -40^\circ\text{C to }+115^\circ\text{C}$, unless otherwise noted.

Table 1. ADuC7034 Electrical Specifications

Parameter	Test Conditions/Comments	Min	Typ	Max	Unit
ADC SPECIFICATIONS					
Conversion Rate ¹	Chop off, ADC normal operating mode	4		8000	Hz
	Chop on, ADC normal operating mode	4		2600	Hz
	Chop on, ADC low power mode	1		650	Hz
Current Channel					
No Missing Codes ¹	Valid for all ADC update rates and ADC modes	16			Bits
Integral Nonlinearity ^{1,2}			±10	±60	ppm of FSR
Offset Error ^{2,3,4,5}	Chop off, 1 LSB = (36.6/gain) μV	-10	±3	+10	LSB
Offset Error ^{1,3,6}	Chop on	-2	±0.5	+2	μV
Offset Error ^{1,3}	Chop on, low power or low power plus mode, MCU powered down	0	-200	-650	nV
Offset Error ^{1,3}	Chop on, normal mode, CD = 1	0	-1.5	-5	μV
Offset Error Drift ⁶	Chop off, valid for ADC gains of 4 to 64, normal mode		0.03		LSB/ $^\circ\text{C}$
Offset Error Drift ⁶	Chop off, valid for ADC gains of 128 to 512, normal mode		30		nV/ $^\circ\text{C}$
Offset Error Drift ⁶	Chop on		10		nV/ $^\circ\text{C}$
Total Gain Error ^{1,3,7,8,9,10}	Normal mode	-0.5	±0.1	+0.5	%
Total Gain Error ^{1,3,7,9}	Low power mode, using ADCREF MMR	-4	±0.2	+4	%
Total Gain Error ^{1,3,7,9,11}	Low power-plus mode, using precision V_{REF}	-1	±0.2	+1	%
Gain Drift			3		ppm/ $^\circ\text{C}$
PGA Gain Mismatch Error			±0.1		%
Output Noise ^{1,12,13}	4 Hz update rate, gain = 512, chop enabled		60	90	nV rms
	4 Hz update rate, gain = 512, chop disabled		75	115	nV rms
	10 Hz update rate, gain = 512, chop enabled		100	150	nV rms
	10 Hz update rate, gain = 512, chop disabled		120	180	nV rms
	1 kHz update rate, gain ≥ 64 , chop enabled		0.8	1.2	$\mu\text{V rms}$
	1 kHz update rate, gain ≥ 64 , (ADCFLT = 0x0101)		1	1.5	$\mu\text{V rms}$
	1 kHz update rate, gain = 512, chop disabled		0.6	0.9	$\mu\text{V rms}$
	1 kHz update rate, gain = 32, chop disabled		0.8	1.2	$\mu\text{V rms}$
	1 kHz update rate, gain = 8, chop enabled		2.1	4.1	$\mu\text{V rms}$
	1 kHz update rate, gain = 8, chop disabled		1.6	2.4	$\mu\text{V rms}$
	1 kHz update rate, gain = 8, (ADCFLT = 0x0101)		2.6	3.9	$\mu\text{V rms}$
	1 kHz update rate, gain = 4, chop disabled		2.0	2.8	$\mu\text{V rms}$
	8 kHz update rate, gain = 32		2.5	3.5	$\mu\text{V rms}$
	8 kHz update rate, gain = 4		14	21	$\mu\text{V rms}$
	ADC low power mode, $f_{ADC} = 10\text{ Hz}$, gain = 128		1.25	1.9	$\mu\text{V rms}$
	ADC low power mode, $f_{ADC} = 1\text{ Hz}$, gain = 128		0.35	0.5	$\mu\text{V rms}$
	ADC low power-plus mode, $f_{ADC} = 1\text{ Hz}$, gain = 512		0.1	0.15	$\mu\text{V rms}$
ADC low power-plus mode, $f_{ADC} = 250\text{ Hz}$, gain = 512, chop enabled		0.6	0.9	$\mu\text{V rms}$	
Voltage Channel¹⁴					
No Missing Codes ¹	Valid at all ADC update rates	16			Bits
Integral Nonlinearity ¹			±10	±60	ppm of FSR
Offset Error ^{3,5}	Chop off, 1 LSB = 439.5 μV	-10	±1	+10	LSB
Offset Error ^{1,3}	Chop on		0.3	1	LSB
Offset Error Drift	Chop off		0.03		LSB/ $^\circ\text{C}$

Parameter	Test Conditions/Comments	Min	Typ	Max	Unit
Total Gain Error ^{1, 3, 7, 10, 15}	Includes resistor mismatch	-0.25	±0.06	+0.25	%
Total Gain Error ^{1, 3, 7, 10, 15}	Temperature range = -25°C to +65°C	-0.15	±0.03	+0.15	%
Gain Drift	Includes resistor mismatch drift		3		ppm/°C
Output Noise ^{1, 12, 16}	4 Hz update rate, chop enabled		60	90	µV rms
	10 Hz update rate, chop enabled		60	90	µV rms
	1 kHz update rate		180	270	µV rms
	1 kHz update rate, chop enabled		240	307	µV rms
	1 kHz update rate (ADCFLT = 0x0101)		270	405	µV rms
	8 kHz update rate		1600	2400	µV rms
Temperature Channel					
No Missing Codes ¹	Valid at all ADC update rates	16			Bits
Integral Nonlinearity ¹			±10	±60	ppm of FSR
Offset Error ^{3, 4, 5, 17}	Chop off, 1 LSB = 19.84 µV (in unipolar mode), tested at gain of 4	-10	±3	+10	LSB
Offset Error ^{1, 3}	Chop on	-5	+1	+5	LSB
Offset Error Drift	Chop off		0.03		LSB/°C
Total Gain Error ^{1, 3, 15}		-0.2	±0.06	+0.2	%
Gain Drift			3		ppm/°C
Output Noise ¹	1 kHz update rate		7.5	11.25	µV rms
ADC SPECIFICATIONS ANALOG INPUT	Internal V _{REF} = 1.2 V				
Current Channel					
Absolute Input Voltage Range	Applies to both IIN+ and IIN-	-200		+300	mV
Input Voltage Range ^{18, 19}	Gain = 1 ²⁰		±1.2		V
	Gain = 2 ²⁰		±600		mV
	Gain = 4 ²⁰		±300		mV
	Gain = 8		±150		mV
	Gain = 16		±75		mV
	Gain = 32		±37.5		mV
	Gain = 64		±18.75		mV
	Gain = 128		±9.375		mV
	Gain = 256		±4.68		mV
	Gain = 512		±2.3		mV
Input Leakage Current ¹		-3		+3	nA
Input Offset Current ^{1, 21}			0.5	1.5	nA
Voltage Channel					
Absolute Input Voltage Range		4		18	V
Input Voltage Range			0 to 28.8		V
VBAT Input Current	VBAT = 18 V	3	5.5	8	µA
Temperature Channel	V _{REF} = (REG_AVDD, GND_SW)/2				
Absolute Input Voltage Range		100		1300	mV
Input Voltage Range			0 to V _{REF}		V
VTEMP Input Current ¹			2.5	100	nA
VOLTAGE REFERENCE					
ADC Precision Reference					
Internal V _{REF}			1.2		V
Power-Up Time ¹			0.5		ms
Initial Accuracy ¹	Measured at T _A = 25°C	-0.15		+0.15	%
Temperature Coefficient ^{1, 22}		-20	±5	+20	ppm/°C
Reference Long-Term Stability ²³			100		ppm/1000 hr
External Reference Input Range ²⁴		0.1		1.3	V
V _{REF} Divide-by-2 Initial Error ¹			0.1	0.3	%
ADC Low Power Reference					
Internal V _{REF}			1.2		V

Parameter	Test Conditions/Comments	Min	Typ	Max	Unit
Initial Accuracy	Measured at $T_A = 25^\circ\text{C}$	-5		+5	%
Initial Accuracy ¹	Using ADCREF, measured at $T_A = 25^\circ\text{C}$		0.1		%
Temperature Coefficient ^{1,22}		-300	± 150	+300	ppm/ $^\circ\text{C}$
RESISTIVE ATTENUATOR					
Divider Ratio			24		
Resistor Mismatch Drift			3		ppm/ $^\circ\text{C}$
ADC GROUND SWITCH					
Resistance	Direct path to ground 20 k Ω resistor selected	10	10 20	30	Ω k Ω
Input Current				6	mA
TEMPERATURE SENSOR ²⁵					
Accuracy	After user calibration MCU in power down or standby mode MCU in power down or standby mode, temperature range = -25°C to $+65^\circ\text{C}$		± 3 ± 2		$^\circ\text{C}$ $^\circ\text{C}$
POWER-ON RESET (POR)					
POR Trip Level	Refers to voltage at VDD pin	2.85	3.0	3.15	V
POR Hysteresis			300		mV
RESET Timeout from POR			20		ms
LOW VOLTAGE FLAG (LVF)					
LVF Level	Refers to voltage at VDD pin	1.9	2.1	2.3	V
POWER SUPPLY MONITOR (PSM)					
PSM Trip Level	Refers to voltage at VDD pin		6.0		V
WATCHDOG TIMER (WDT)					
Timeout Period ¹	32.768 kHz clock, 256 prescale	0.008		512	sec
Timeout Step Size			7.8		ms
FLASH/EE MEMORY ¹					
Endurance ²⁶		10,000			Cycles
Data Retention ²⁷		20			Years
DIGITAL INPUTS	All digital inputs except NTRST				
Input Leakage Current	Input (high) = REG_DVDD		± 1	± 10	μA
Input Pull-up Current	Input (low) = 0 V	-80	-20	-10	μA
Input Capacitance			10		pF
Input Leakage Current	NTRST only: input (low) = 0 V		± 1	± 10	μA
Input Pull-down Current	NTRST only: input (high) = REG_DVDD	30	55	100	μA
LOGIC INPUTS ¹	All logic inputs				
VINL, Input Low Voltage				0.4	V
VINH, Input High Voltage		2.0			V
CRYSTAL OSCILLATOR ¹					
Logic Inputs, XTAL1 Only					
VINL, Input Low Voltage				0.8	V
VINH, Input High Voltage		1.7			V
XTAL1 Capacitance			12		pF
XTAL2 Capacitance			12		pF
ON-CHIP OSCILLATORS					
Low Power Oscillator			131.072		kHz
Accuracy ²⁸	Includes drift data from 1000 hour life test	-3		+3	%
Precision Oscillator			131.072		kHz
Accuracy	Includes drift data from 1000 hour life test	-1		+1	%
MCU CLOCK RATE	8 programmable core clock selections within this range (binary divisions 1, 2, 4, 8... 64, 128)	0.160	10.24	20.48	MHz
MCU START-UP TIME					
At Power-On	Includes kernel power-on execution time		25		ms
After Reset Event	Includes kernel power-on execution time		5		ms

Parameter	Test Conditions/Comments	Min	Typ	Max	Unit
From MCU Power-Down Oscillator Running Wake Up from Interrupt Wake Up from LIN Crystal Powered Down Wake Up from Interrupt Internal PLL Lock Time			2 2 500 1		ms ms ms ms
LIN INPUT/OUTPUT GENERAL	Bus load conditions (CBUS RBU): 1 nF 1 kΩ; 6.8 nF 660 Ω; 10 nF 500 Ω				
Baud Rate		1000		20,000	Bits/sec
VDD	Supply voltage range at which the LIN interface is functional	7		18	V
Input Capacitance			5.5		pF
Input Leakage Current	Input (low) = IO_VSS	-800		-400	μA
LIN Comparator Response Time ¹	Using 22 Ω resistor		38	90	μs
I _{LIN DOM MAX}	Current limit for driver when LIN bus is in dominant state, V _{BAT} = V _{BAT (MAX)}	40		200	mA
I _{LIN_PAS_REC}	Driver off; 7.0 V < V _{LIN} < 18 V; V _{DD} = V _{LIN} - 0.7 V	-20		+20	μA
I _{LIN} ¹	V _{BAT} disconnected, V _{DD} = 0 V, 0 < V _{LIN} < 18 V			10	μA
I _{LIN_PAS_DOM} ¹	Input leakage V _{LIN} = 0 V	-1			mA
I _{LIN_NO_GND} ²⁹	Control unit disconnected from ground, GND = V _{DD} ; 0 V < V _{LIN} < 18 V; V _{BAT} = 12 V	-1		+1	mA
V _{LIN_DOM} ¹	LIN receiver dominant state, V _{DD} > 7.0 V			0.4 V _{DD}	V
V _{LIN_REC} ¹	LIN receiver recessive state, V _{DD} > 7.0 V	0.6 V _{DD}			V
V _{LIN_CNT} ¹	LIN receiver center voltage, V _{DD} > 7.0 V	0.475 V _{DD}	0.5 V _{DD}	0.525 V _{DD}	V
V _{HYS} ¹	LIN receiver hysteresis voltage			0.175 V _{DD}	V
V _{LIN_DOM_DRV_LOSUP} ¹	LIN dominant output voltage, V _{DD} = 7 V			1.2	V
R _L 500 Ω					V
R _L 1000 Ω		0.6			V
V _{LIN_DOM_DRV_HISUP} ¹	LIN dominant output voltage, V _{DD} = 18 V			2	V
R _L 500 Ω					V
R _L 1000 Ω		0.8			V
V _{LIN_RECESSIVE}	LIN recessive output voltage	0.8 V _{DD}			V
V _{BAT} Shift ²⁹		0		0.1 V _{DD}	V
GND Shift ²⁹		0		0.1 V _{DD}	V
R _{SLAVE}	Slave termination resistance	20	30	47	kΩ
V _{SERIAL DIODE} ²⁹	Voltage drop at the Serial Diode D _{Ser_Int}	0.4	0.7	1	V
Symmetry of Transmit Propagation Delay ¹	V _{DD (MIN)} = 7 V	-2		+2	μs
Receive Propagation Delay ¹	V _{DD (MIN)} = 7 V			6	μs
Symmetry of Receive Propagation Delay ¹	V _{DD (MIN)} = 7 V	-2		+2	μs
LIN VERSION 2.0 SPECIFICATION	Bus load conditions (CBUS RBUS): 1 nF 1 kΩ; 6.8 nF 660 Ω; 10 nF 500 Ω				
D1	Duty Cycle 1, TH _{REC(MAX)} = 0.744 × V _{BAT} , TH _{DOM(MAX)} = 0.581 × V _{BAT} , V _{SUP} = 7.0 V . . . 18 V; t _{BIT} = 50 μs, D1 = t _{BUS_REC(MIN)} / (2 × t _{BIT})	0.396			
D2	Duty Cycle 2, TH _{REC(MIN)} = 0.284 × V _{BAT} , TH _{DOM(MIN)} = 0.422 × V _{BAT} , V _{SUP} = 7.0 V . . . 18 V; t _{BIT} = 50 μs, D2 = t _{BUS_REC(MAX)} / (2 × t _{BIT})			0.581	
BSD INPUT/OUTPUT ³⁰					
Baud Rate		1164	1200	1236	Bits/sec

Parameter	Test Conditions/Comments	Min	Typ	Max	Unit
Input leakage current	Input (high) = VDD or input (low) = IO_VSS	-50		+50	μA
V _{OL} , Output Low Voltage				1.2	V
V _{OH} , Output High Voltage		0.8 V _{DD}		V _{DD}	V
I _{o(sc)} Short-Circuit Output Current	V _{BSD} = V _{DD} = 12 V	50	80	120	mA
V _{INL} , Input Low Voltage				1.8	V
V _{INH} , Input High Voltage		0.7 V _{DD}			V
WAKE	R _L = 300 Ω, C _{BUS} = 91 nF, R _{LIMIT} = 39 Ω				
V _{DD} ¹	Supply voltage range at which the WU pin is functional	7		18	V
Input Leakage Current	Input (high) = VDD	0.4		2.1	mA
	Input (low) = IO_VSS	-50		+50	μA
V _{OH} ³¹	Output high level	5			V
V _{OL} ³¹	Output low level			2	V
V _{IH}	Input high level	4.6			V
V _{IL}	Input low level			1.2	V
Monoflop Timeout	Timeout period	0.6	1.3	2	sec
I _{o(sc)} Short-Circuit Output Current		65	100		mA
SERIAL TEST INTERFACE	R _L = 500 Ω, C _{BUS} = 2.4 nF, R _{LIMIT} = 39 Ω				
Baud Rate				40	kbps
Input Leakage Current	Input (high) = VDD or Input (low) = IO_VSS	-50		+70	μA
V _{DD}	Supply voltage range for which STI is functional	7		18	V
V _{OH}	Output high level	0.6			V _{DD}
V _{OL}	Output low level			0.4	V _{DD}
V _{IH}	Input high level	0.6			V _{DD}
V _{IL}	Input low level			0.4	V _{DD}
PACKAGE THERMAL SPECIFICATIONS					
Thermal Shutdown ^{1, 32}		140	150	160	°C
Thermal Impedance (θ _{JA}) ³³	48-lead LFCSP, stacked die		45		°C/W
POWER REQUIREMENTS					
Power Supply Voltages					
VDD (Battery Supply)		3.5		18	V
REG_DVDD, REG_AVDD ³⁴		2.5	2.6	2.7	V
Power Consumption					
I _{DD} (MCU Normal Mode) ³⁵	MCU clock rate = 10.24 MHz, ADC off		10	20	mA
	MCU clock rate = 20.48 MHz, ADC off		20		mA
I _{DD} (MCU Powered Down) ¹	ADC low power mode, measured over the range of T _A = -10°C to +40°C, continuous ADC conversion		300	400	μA
	ADC low power mode, measured over the range of T _A = -40°C to +85°C, continuous ADC conversion		300	500	μA
	ADC low power plus mode, measured over an ambient temperature range of T _A = -10°C to +40°C, continuous ADC conversion		520	700	μA
	Average current, measured with wake and watchdog timer clocked from the low power oscillator, T _A = -40°C to +85°C		120	300	μA
I _{DD} (MCU Powered Down)	Average current, measured with wake and watchdog timer clocked from low power oscillator over a range of T _A = -10°C to +40°C		120	175	μA
I _{DD} (Current ADC)			1.7		mA
I _{DD} (Voltage/Temperature ADC)			0.5		mA
I _{DD} (Precision Oscillator)			400		μA

¹ These numbers are not production tested, but are guaranteed by design and/or characterization data at production release.

² Valid for current ADC gain setting of PGA = 4 to 64.

³ These numbers include temperature drift.

- ⁴ Tested at gain range = 4; self-offset calibration removes this error.
- ⁵ Measured with an internal short after an initial offset calibration.
- ⁶ Measured with an internal short.
- ⁷ These numbers include internal reference temperature drift.
- ⁸ Factory calibrated at gain = 1.
- ⁹ System calibration at a specific gain range removes the error at this gain range. At that temperature
- ¹⁰ Includes an initial system calibration.
- ¹¹ Using ADC normal mode voltage reference.
- ¹² 1 kHz update rate chop enable is achieved with ADCFLT = 0x8101; yet with chop off, ADCFLT = 0x0007.
- ¹³ Typical noise in low power modes is measured with chop enabled.
- ¹⁴ Voltage channel specifications include resistive attenuator input stage.
- ¹⁵ System calibration removes this error at that temperature.
- ¹⁶ RMS noise is referred to voltage attenuator input, for example, at $f_{ADC} = 1$ kHz, typical rms noise at the ADC input is 7.5 μ V, scaled by the attenuator (24) yields these input referred noise figures.
- ¹⁷ Valid after an initial self calibration.
- ¹⁸ In ADC low power mode, the input range is fixed at ± 9.375 mV. In ADC low power plus mode, the input range is fixed at ± 2.34375 mV.
- ¹⁹ It is possible to extend the ADC input range by up to 10% by modifying the factory set value of the gain calibration register or using system calibration. This approach can also be used to reduce the ADC input range (LSB size).
- ²⁰ Limited by minimum/maximum absolute input voltage range.
- ²¹ Valid for a differential input less than 10 mV.
- ²² Measured using box method.
- ²³ The long-term stability specification is noncumulative. The drift in subsequent 1000 hour periods is significantly lower than in the first 1000 hour period.
- ²⁴ References of up to REG_AVDD can be accommodated by enabling an internal divide-by-2.
- ²⁵ Die temperature.
- ²⁶ Endurance is qualified to 10,000 cycles as per JEDEC Std. 22 Method A117 and measured at -40°C , $+25^{\circ}\text{C}$, and $+125^{\circ}\text{C}$. Typical endurance at 25°C is 170,000 cycles.
- ²⁷ Retention lifetime equivalent at junction temperature (T_j) = 85°C as per JEDEC Std. 22 Method A117. Retention lifetime derates with junction temperature.
- ²⁸ Low Power oscillator can be calibrated against either the precision oscillator or the external 32.768 kHz crystal in user code.
- ²⁹ These numbers are not production tested, but are supported by LIN compliance testing.
- ³⁰ BSD electrical specifications, except high and low voltage levels, are per LIN 2.0 with pull-up resistor disabled and $C_{Load} = 10$ nF maximum.
- ³¹ Specified after R_{LIMIT} of 39 Ω .
- ³² The MCU core is not shutdown but interrupted, and high voltage I/O pins are disabled in response to a thermal shutdown event.
- ³³ Thermal impedance can be used to calculate the thermal gradient from ambient to die temperature.
- ³⁴ Internal regulated supply available at REG_DVDD ($I_{SOURCE} = 5$ mA), and REG_AVDD ($I_{SOURCE} = 1$ mA).
- ³⁵ Typical, additional supply current consumed during Flash/EE memory program and erase cycles is 7 mA and 5 mA, respectively.

TIMING SPECIFICATIONS

SPI Timing Specifications

Table 2. SPI Master Mode Timing (PHASE Mode = 1)

Parameter	Description	Min	Typ	Max	Unit
t_{SL}	SCLK low pulse width ¹		$(SPIDIV + 1) \times t_{HCLK}$		ns
t_{SH}	SCLK high pulse width ¹		$(SPIDIV + 1) \times t_{HCLK}$		ns
t_{DAV}	Data output valid after SCLK edge ²			$(2 \times t_{UCLK}) + (2 \times t_{HCLK})$	ns
t_{DSU}	Data input setup time before SCLK edge	0			ns
t_{DHD}	Data input hold time after SCLK edge ²	$3 \times t_{UCLK}$			ns
t_{DF}	Data output fall time		3.5		ns
t_{DR}	Data output rise time		3.5		ns
t_{SR}	SCLK rise time		3.5		ns
t_{SF}	SCLK fall time		3.5		ns

¹ t_{HCLK} depends on the clock divider or CD bits in PLLCON MMR. $t_{HCLK} = t_{UCLK}/2^{CD}$.

² $t_{UCLK} = 48.8$ ns. It corresponds to the 20.48 MHz internal clock from the PLL before the clock divider.

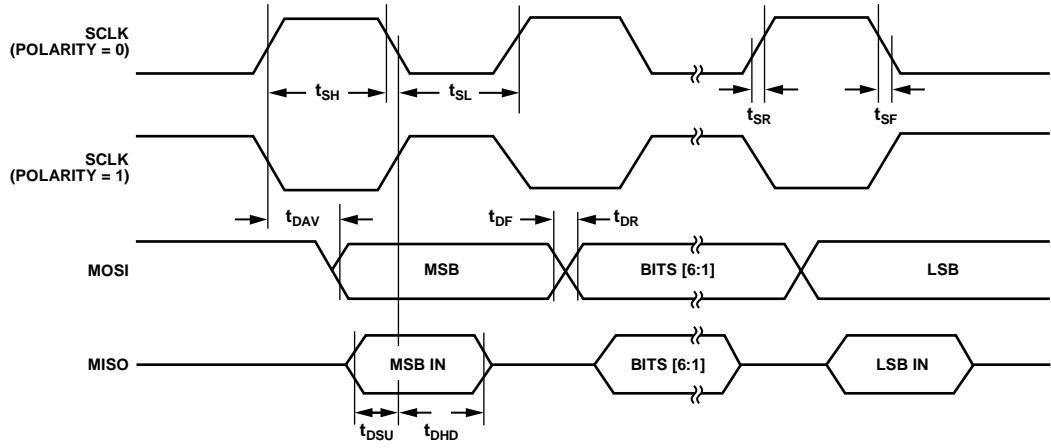

Figure 2. SPI Master Mode Timing (PHASE Mode = 1)

05B94-002

Table 3. SPI Master Mode Timing (PHASE Mode = 0)

Parameter	Description	Min	Typ	Max	Unit
t _{SL}	SCLK low pulse width ¹		(SPIDIV + 1) × t _{HCLK}		ns
t _{SH}	SCLK high pulse width ¹		(SPIDIV + 1) × t _{HCLK}		ns
t _{DAV}	Data output valid after SCLK edge ²			(2 × t _{UCLK}) + (2 × t _{HCLK})	ns
t _{DOSU}	Data output setup before SCLK edge		½ t _{SL}		ns
t _{DSU}	Data input setup time before SCLK edge	0			ns
t _{DHD}	Data input hold time after SCLK edge ²	3 × t _{UCLK}			ns
t _{DF}	Data output fall time		3.5		ns
t _{DR}	Data output rise time		3.5		ns
t _{SR}	SCLK rise time		3.5		ns
t _{SF}	SCLK fall time		3.5		ns

¹ t_{HCLK} depends on the clock divider or CD bits in PLLCON MMR. t_{HCLK} = t_{UCLK}/2^{CD}.

² t_{UCLK} = 48.8 ns. It corresponds to the 20.48 MHz internal clock from the PLL before the clock divider.

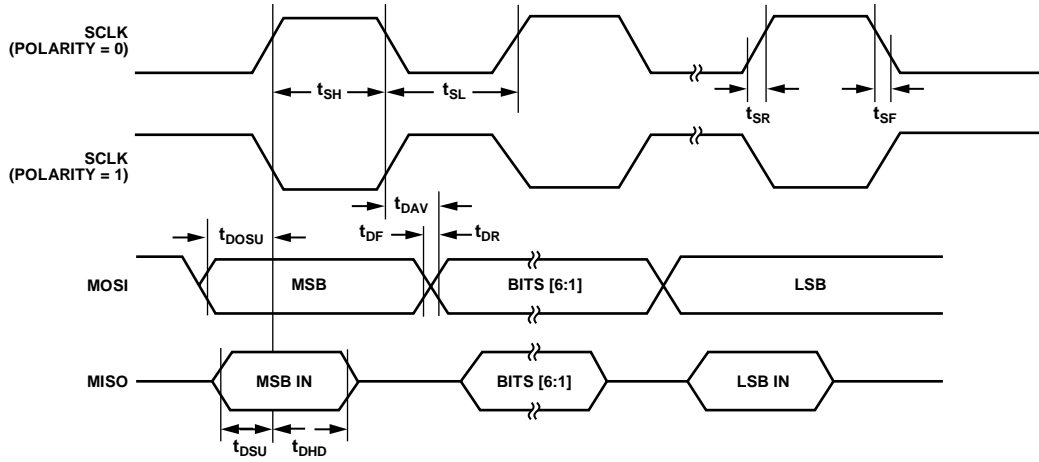

Figure 3. SPI Master Mode Timing (PHASE Mode = 0)

05994-003

Table 4. SPI Slave Mode Timing (PHASE Mode = 1)

Parameter	Description	Min	Typ	Max	Unit
$t_{\overline{SS}}$	\overline{SS} to SCLK edge		$\frac{1}{2} t_{SL}$		ns
t_{SL}	SCLK low pulse width ¹		$(SPIDIV + 1) \times t_{HCLK}$		ns
t_{SH}	SCLK high pulse width ¹		$(SPIDIV + 1) \times t_{HCLK}$		ns
t_{DAV}	Data output valid after SCLK edge ²			$(3 \times t_{UCLK}) + (2 \times t_{HCLK})$	ns
t_{DSU}	Data input setup time before SCLK edge	0			ns
t_{DHD}	Data input hold time after SCLK edge ²	$4 \times t_{UCLK}$			ns
t_{DF}	Data output fall time		3.5		ns
t_{DR}	Data output rise time		3.5		ns
t_{SR}	SCLK rise time		3.5		ns
t_{SF}	SCLK fall time		3.5		ns
t_{SFS}	\overline{SS} high after SCLK edge		$\frac{1}{2} t_{SL}$		ns

¹ t_{HCLK} depends on the clock divider or CD bits in PLLCON MMR. $t_{HCLK} = t_{UCLK} / 2^{CD}$.

² $t_{UCLK} = 48.8$ ns. It corresponds to the 20.48 MHz internal clock from the PLL before the clock divider.

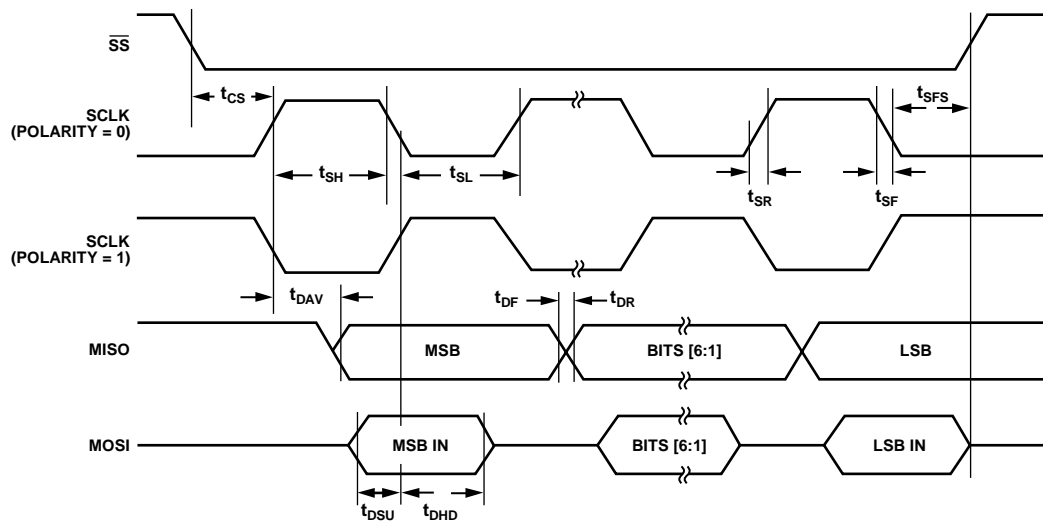

Figure 4. SPI Slave Mode Timing (PHASE Mode = 1)

0599A-004

Table 5. SPI Slave Mode Timing (PHASE Mode = 0)

Parameter	Description	Min	Typ	Max	Unit
$t_{\overline{SS}}$	\overline{SS} to SCLK edge		$\frac{1}{2} t_{SL}$		ns
t_{SL}	SCLK low pulse width ¹		$(SPIDIV + 1) \times t_{HCLK}$		ns
t_{SH}	SCLK high pulse width ¹		$(SPIDIV + 1) \times t_{HCLK}$		ns
t_{DAV}	Data output valid after SCLK edge ²			$(3 \times t_{UCLK}) + (2 \times t_{HCLK})$	ns
t_{DSU}	Data input setup time before SCLK edge	0			ns
t_{DHD}	Data input hold time after SCLK edge ²	$4 \times t_{UCLK}$			ns
t_{DF}	Data output fall time		3.5		ns
t_{DR}	Data output rise time		3.5		ns
t_{SR}	SCLK rise time		3.5		ns
t_{SF}	SCLK fall time		3.5		ns
t_{DOCS}	Data output valid after \overline{SS} edge ²			$(3 \times t_{UCLK}) + (2 \times t_{HCLK})$	ns
t_{SFS}	\overline{SS} high after SCLK edge		$\frac{1}{2} t_{SL}$		ns

¹ t_{HCLK} depends on the clock divider or CD bits in PLLCON MMR. $t_{HCLK} = t_{UCLK}/2^{CD}$.

² $t_{UCLK} = 48.8$ ns. It corresponds to the 20.48 MHz internal clock from the PLL before the clock divider.

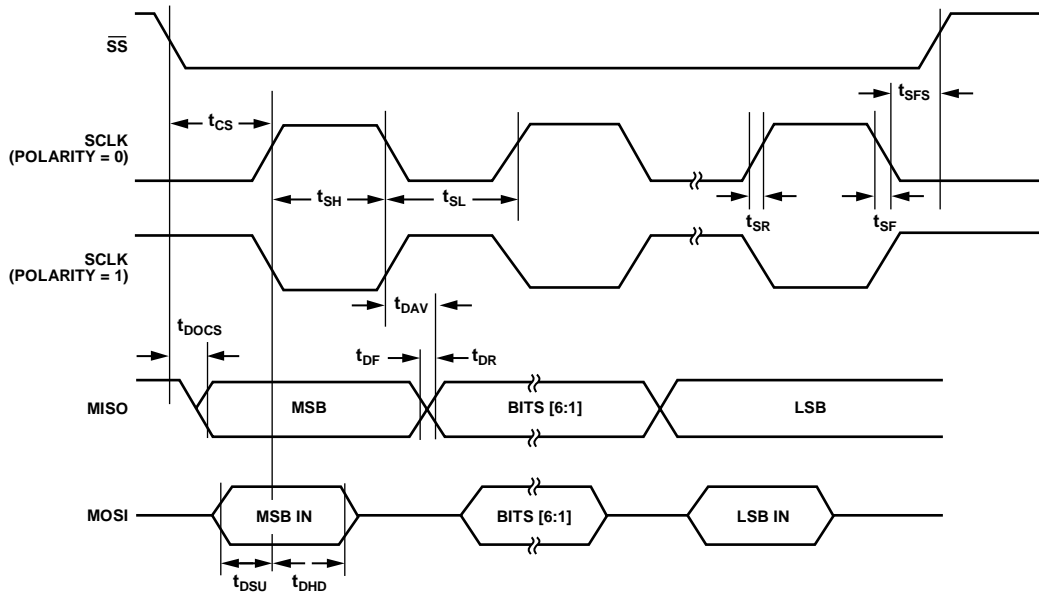

Figure 5. SPI Slave Mode Timing (PHASE Mode = 0)

01994-0105

LIN Timing Specifications

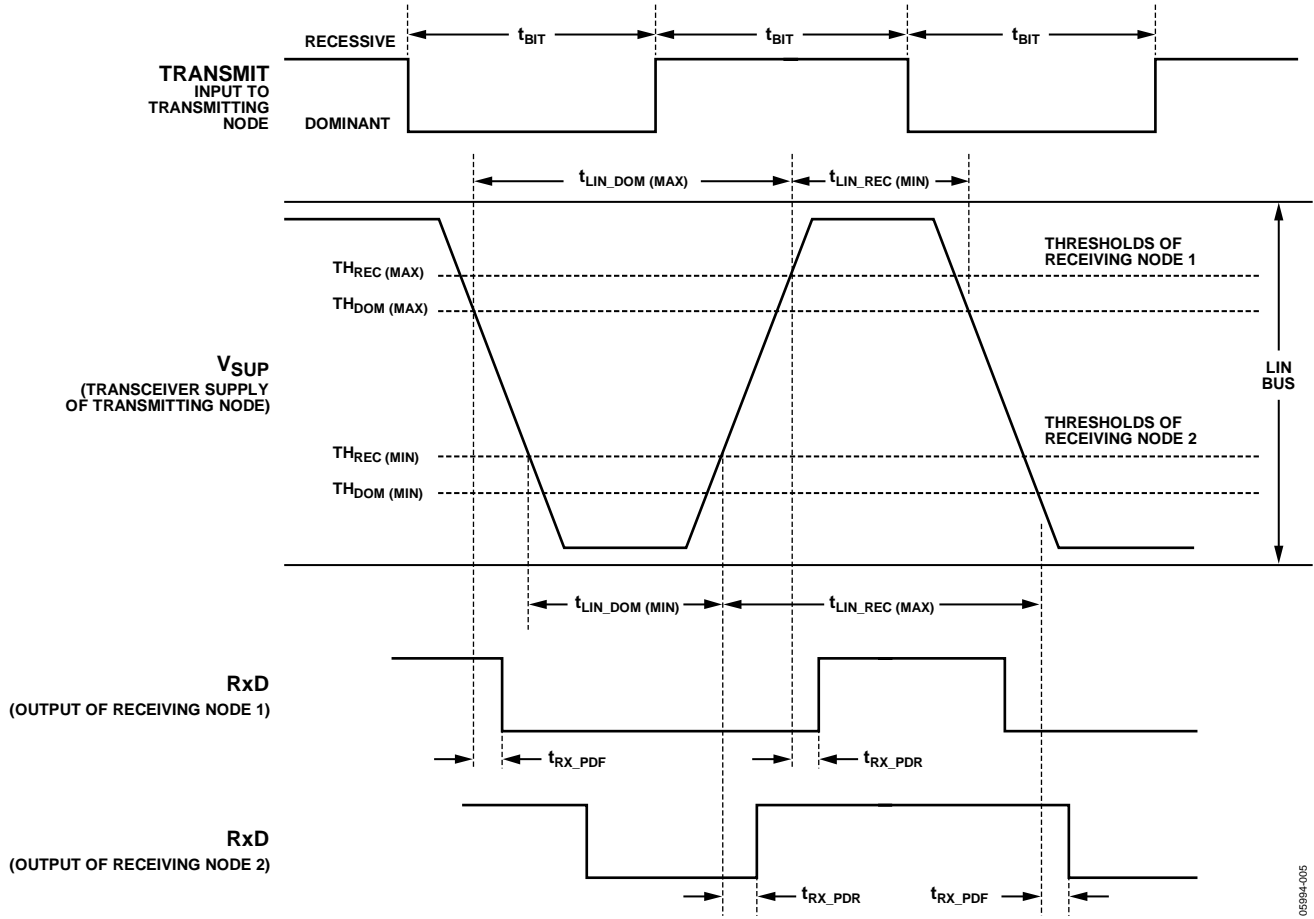

Figure 6. LIN 2.0 Timing Specification

05894-005

ABSOLUTE MAXIMUM RATINGS

$T_A = -40^{\circ}\text{C}$ to $+115^{\circ}\text{C}$, unless otherwise noted.

Table 6.

Parameter	Rating
AGND to DGND to VSS to IO_VSS	-0.3 V to +0.3 V
VBAT to AGND	-22 V to +40 V
VDD to VSS	-0.3 V to +33 V
VDD to VSS for 1 sec	-0.3 V to +40 V
LIN to IO_VSS	-16 V to +40 V
STI/WU to IO_VSS	-3 V to +33 V
Wake Continuous Current	50 mA
High Voltage I/O Pins Short-Circuit Current	100 mA
Digital I/O Voltage to DGND	-0.3 V to $\text{REG_DV}_{\text{DD}} + 0.3 \text{ V}$
VREF to AGND	-0.3 V to $\text{REG_AV}_{\text{DD}} + 0.3 \text{ V}$
ADC Inputs to AGND	-0.3 V to $\text{REG_AV}_{\text{DD}} + 0.3 \text{ V}$
Storage Temperature	125°C
Junction Temperature	
Transient	150°C
Continuous	130°C
Lead Temperature	
Soldering Reflow (15 sec)	260°C

Stresses above those listed under Absolute Maximum Ratings may cause permanent damage to the device. This is a stress rating only; functional operation of the device at these or any other conditions above those indicated in the operational section of this specification is not implied. Exposure to absolute maximum rating conditions for extended periods may affect device reliability.

ESD CAUTION



ESD (electrostatic discharge) sensitive device.

Charged devices and circuit boards can discharge without detection. Although this product features patented or proprietary protection circuitry, damage may occur on devices subjected to high energy ESD. Therefore, proper ESD precautions should be taken to avoid performance degradation or loss of functionality.

PIN CONFIGURATION AND FUNCTION DESCRIPTIONS

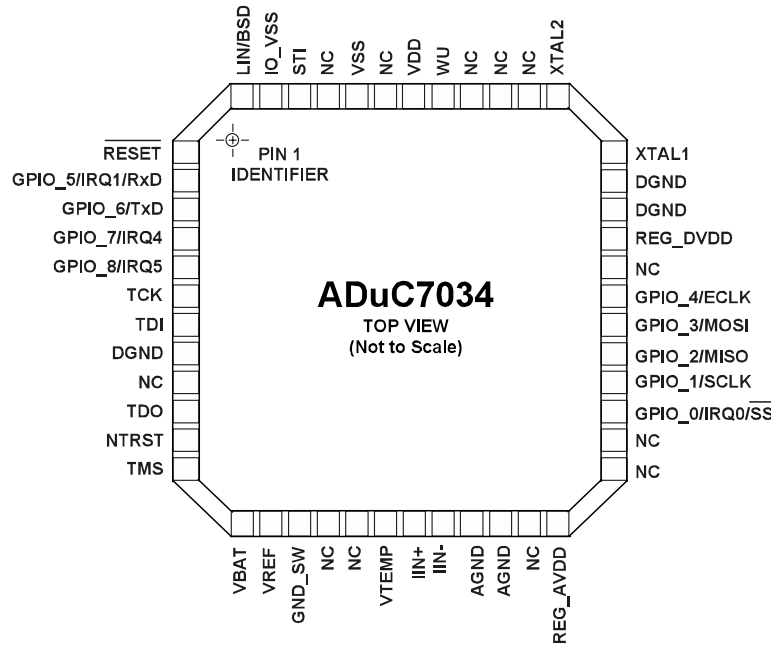

Figure 7. Pin Configuration

Table 7. Pin Function Descriptions

Pin No.	Mnemonic	Type ¹	Description
1	RESET	I	Reset Input Pin. Active low. This pin has an internal, weak, pull-up resistor to REG_DVDD. When not in use, this pin remains unconnected. For added security and robustness, it is recommended that this pin be strapped via a resistor to REG_DVDD.
2	GPIO_5/IRQ1/RxD	I/O	General-Purpose Digital Input/Output 5, External Interrupt Request 1, or Receive Data. This is a multifunction pin. By default and after power-on-reset, this pin configures as an input. The pin has an internal, weak, pull-up resistor and when not in use, it is left unconnected. This multifunction pin can be configured in one of three states, namely General-Purpose Digital I/O 5. External Interrupt Request 1, active high. Receive data for UART serial port.
3	GPIO_6/TxD	I/O	General-Purpose Digital Input/Output 6, Transmit Data. This is a multifunction pin. By default and after power-on-reset, this pin configures as an input. The pin has an internal weak pull-up resistor and when not in use, it is left unconnected. This multifunction pin can be configured in one of two states, namely General-Purpose Digital I/O 6. Transmit data for UART serial port.
4	GPIO_7/IRQ4	I/O	General-Purpose Digital Input/Output 7, External Interrupt Request. This is a multifunction pin. By default and after power-on-reset, this pin configures as an input. The pin has an internal, weak, pull-up resistor and when not in use, it is left unconnected. This multifunction pin can be configured in one of two states, namely General-Purpose Digital I/O 7. External Interrupt Request 4, active high.
5	GPIO_8/IRQ5	I/O	General-Purpose Digital Input/Output 8, External Interrupt Request. This is a multifunction pin. By default and after power-on-reset, this pin configures as an input. The pin has an internal weak pull-up resistor and when not in use, it is left unconnected. This multifunction pin can be configured in one of two states, namely General-Purpose Digital I/O 8. External Interrupt Request 5, active high.
6	TCK	I	JTAG Test Clock. This clock input pin is one of the standard 5-pin JTAG debug ports on the part. TCK is an input pin only and has an internal weak pull-up resistor. This pin is left unconnected when not in use.

Pin No.	Mnemonic	Type ¹	Description
7	TDI	I	JTAG Test Data Input. This data input pin is one of the standard 5-pin JTAG debug ports on the part. TDI is an input pin only and has an internal, weak, pull-up resistor. This pin can be left unconnected when not in use.
8, 34, 35	DGND	S	Ground Reference for On-Chip Digital Circuits.
9, 16, 23, 32, 38 to 40, 43, 45	NC		No Connect. These pins are not internally connected, but are reserved for possible future use. Therefore, do not externally connect these pins. These pins can be grounded, if required.
17, 25, 26	NC		No Connect. These pins are internally connected, and are reserved for possible future use. Therefore, do not externally connect these pins. These pins can be grounded, if required.
10	TDO	O	JTAG Test Data Output. This data output pin is one of the standard 5-pin JTAG debug ports on the part. TDO is an output pin only. At power-on, this output is disabled and pulled high via an internal, weak, pull-up resistor. This pin is left unconnected when not in use.
11	NTRST	I	JTAG Test Reset. This reset input pin is one of the standard 5-pin JTAG debug ports on the part. NTRST is an input pin only and has an internal, weak, pull-down resistor. This pin remains unconnected when not in use. NTRST is also monitored by the on-chip kernel to enable LIN boot load mode.
12	TMS	I	JTAG Test Mode Select. This mode select input pin is one of the standard 5-pin JTAG debug ports on the part. TMS is an input pin only and has an internal, weak, pull-up resistor. This pin is left unconnected when not in use.
13	VBAT	I	Battery Voltage Input to Resistor Divider.
14	VREF	I	External Reference Input Terminal. When this input is not used, connect it directly to the AGND system ground. It can also be left unconnected.
15	GND_SW	I	Switch to Internal Analog Ground Reference. This pin is the negative input for the external temperature channel and external reference. When this input is not used, connect it directly to the AGND system ground.
18	VTEMP	I	External Pin for NTC/PTC Temperature Measurement.
19	IIN+	I	Positive Differential Input for Current Channel.
20	IIN-	I	Negative Differential Input for Current Channel.
21, 22	AGND	S	Ground Reference for On-Chip Precision Analog Circuits.
24	REG_AVDD	S	Nominal 2.6 V Output from On-Chip Regulator.
27	GPIO_0/IRQ0/ \overline{SS}	I/O	General-Purpose Digital Input/Output 0, External Interrupt Request 0, or SPI Interface. This is a multifunction pin. By default and after power-on-reset, this pin is configured as an input. The pin has an internal, weak, pull-up resistor and if not being used, it can be left unconnected. This multifunction pin can be configured in one of three states, namely: <ul style="list-style-type: none"> General-Purpose Digital I/O 0. External Interrupt Request 0, active high. SPI interface, slave select input.
28	GPIO_1/SCLK	I/O	General-Purpose Digital Input/Output 1, SPI Interface. This is a multifunction pin. By default and after power-on-reset, this pin is configured as an input. The pin has an internal weak pull-up resistor and if not being used, it is left unconnected. This multifunction pin can be configured in one of two states, namely <ul style="list-style-type: none"> General-Purpose Digital I/O 1. SPI interface, serial clock input.
29	GPIO_2/MISO	I/O	General-Purpose Digital Input/Output 2. This is a multifunction pin. By default and after power-on-reset, this pin is configured as an input. The pin has an internal, weak, pull-up resistor and if not being used, it is left unconnected. This multifunction pin can be configured in one of two states, namely <ul style="list-style-type: none"> General-Purpose Digital I/O 2. SPI interface, master input/slave output pin.
30	GPIO_3/MOSI	I/O	General-Purpose Digital Input/Output 3. This is a multifunction pin. By default and after power-on reset, this pin is configured as an input. The pin has an internal, weak, pull-up resistor and if not being used, it can be left unconnected. This multifunction pin can be configured in one of two states, namely: <ul style="list-style-type: none"> General-Purpose Digital I/O 3. SPI interface, master output/slave input pin.

Pin No.	Mnemonic	Type ¹	Description
31	GPIO_4/ECLK	I/O	General-Purpose Digital Input/Output 4. This is a multifunction pin. By default and after power-on reset, this pin is configured as an input. The pin has an internal weak pull-up resistor and if not being used, it is left unconnected. This multifunction pin can be configured in one of two states, namely General-Purpose Digital I/O 4. Output a 2.56 MHz clock.
33	REG_DVDD	S	Nominal 2.6 V output from the on-chip regulator.
36	XTAL1	O	Crystal Oscillator Output. If an external crystal is not used, this pin is left unconnected.
37	XTAL2	I	Crystal Oscillator Input. If an external crystal is not used, connect this pin to the DGND system ground.
41	WU	I/O	High Voltage Wake-Up Pin. This high voltage I/O pin has an internal 10-k Ω pull-down resistor and a high-side driver to VDD. If this pin is not being used, it should not be connected externally.
42	VDD	S	Battery Power Supply to On-Chip Regulator.
44	VSS	S	Ground Reference. This is the ground reference for the internal voltage regulators.
46	STI	I/O	High Voltage Serial Test Interface Output Pin. If this pin is not used, externally connect it to the IO_VSS ground reference.
47	IO_VSS	S	Ground Reference for High Voltage I/O Pins.
48	LIN/BSL	I/O	LIN Serial Interface Input/Output Pin. This is a high voltage pin.

¹ I = input, O = output, S = supply.

TYPICAL PERFORMANCE CHARACTERISTICS

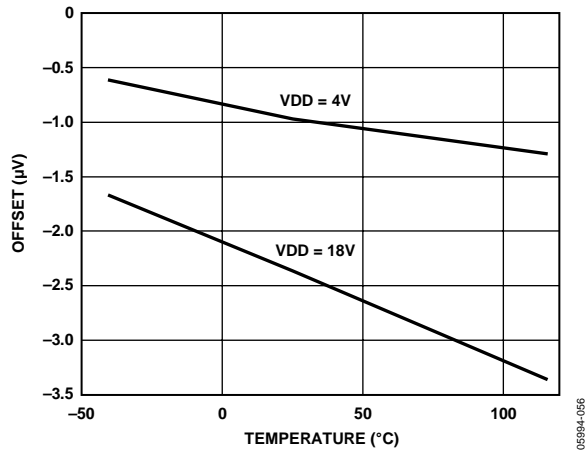

Figure 8. ADC Current Channel Offset vs. Temperature, 10 MHz MCU

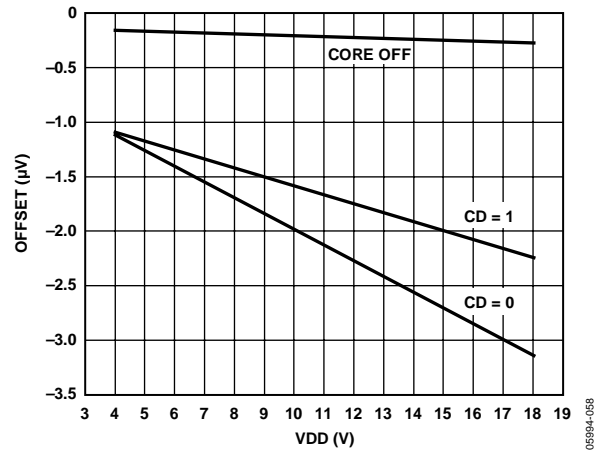

Figure 10. ADC Current Channel Offset vs. Supply @ 25°C

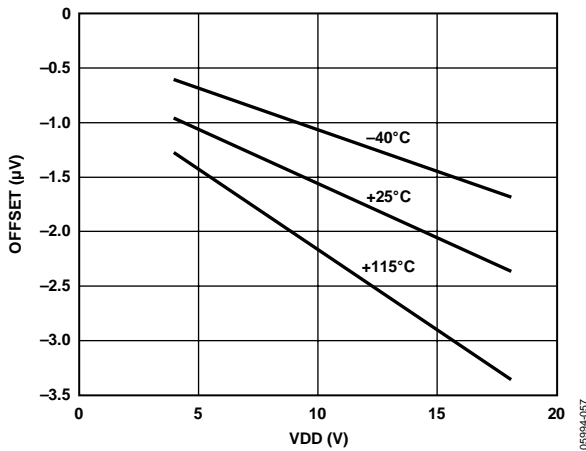

Figure 9. ADC Current Channel Offset vs. VDD (10 MHz, MCU)

TERMINOLOGY

Conversion Rate

The conversion rate specifies the rate at which an output result is available from the ADC, once the ADC has settled.

The sigma-delta (Σ - Δ) conversion techniques used on this part mean that while the ADC front-end signal is oversampled at a relatively high sample rate, a subsequent digital filter is used to decimate the output giving a valid 16-bit data conversion result at output rates from 1 Hz to 8 kHz.

Note that when software switches from one input to another (on the same ADC), the digital filter must first be cleared and then allowed to average a new result. Depending on the configuration of the ADC and the type of filter, this can take multiple conversion cycles.

Integral Nonlinearity (INL)

INL is the maximum deviation of any code from a straight line passing through the endpoints of the transfer function. The endpoints of the transfer function are zero scale, a point $\frac{1}{2}$ LSB below the first code transition, and full scale, a point $\frac{1}{2}$ LSB above the last code transition (111 . . . 110 to 111 . . . 111). The error is expressed as a percentage of full scale.

No Missing Codes

No missing codes is a measure of the differential nonlinearity of the ADC. The error is expressed in bits and specifies the number of codes (ADC results) as 2^N bits, where N = no missing codes, guaranteed to occur through the full ADC input range.

Offset Error

Offset error is the deviation of the first code transition ADC input voltage from the ideal first code transition.

Offset Error Drift

Offset error drift is the variation in absolute offset error with respect to temperature. This error is expressed as LSBs per °C.

Gain Error

Gain error is a measure of the span error of the ADC. It is a measure of the difference between the measured and the ideal span between any two points in the transfer function.

Output Noise

The output noise is specified as the standard deviation (or $1 \times$ Sigma) of ADC output codes distribution collected when the ADC input voltage is at a dc voltage. It is expressed as μ rms. The output, or rms noise, can be used to calculate the effective resolution of the ADC as defined by the following equation:

$$\text{Effective Resolution} = \log_2(\text{full-scale range}/\text{rms noise}) \text{ bits}$$

The peak-to-peak noise is defined as the deviation of codes that fall within $6.6 \times$ Sigma of the distribution of ADC output codes collected when the ADC input voltage is at dc. The peak-to-peak noise is therefore calculated as 6.6 times the rms noise.

The peak-to-peak noise can be used to calculate the ADC (noise free, code) resolution for which there is no code flicker within a $6.6\text{-}\Sigma$ limit as defined by the following equation:

$$\text{Noise Free Code Resolution} = \log_2(\text{full-scale range}/\text{peak-to-peak noise}) \text{ bits}$$

Data Sheet Acronyms

ADC	analog-to-digital converter
ARM	advanced RISC machine
JTAG	joint test action group
LIN	local interconnect network
LSB	least significant byte/bit
LVF	low voltage flag
MCU	microcontroller
MMR	memory mapped register
MSB	most significant byte/bit
OTP	one time programmable
PID	protected identifier
POR	power-on reset
PSM	power supply monitor
rms	root mean square
STI	serial test interface

THEORY OF OPERATION

The ADuC7034-8V is a complete system solution for battery monitoring in 12 V automotive applications. These devices integrate all of the required features to precisely and intelligently monitor, process, and diagnose 12 V battery parameters including battery current, voltage, and temperature over a wide range of operating conditions.

Minimizing external system components, the device is powered directly from the 12 V battery. An on-chip, low dropout regulator generates the supply voltage for three integrated, 16-bit, Σ - Δ ADCs. The ADCs precisely measure battery current, voltage, and temperature to characterize the state of health and charge of the car battery.

A Flash/EE memory-based ARM7™ microcontroller (MCU) is also integrated on-chip. It is used to both preprocess the acquired battery variables and to manage communications from the ADuC7034 to the main electronic control unit (ECU) via a local interconnect network (LIN) interface that is integrated on-chip.

Both the MCU and the ADC subsystem can be individually configured to operate in normal or flexible power saving modes of operation.

In its normal operating mode, the MCU is clocked indirectly from an on-chip oscillator via the phase-locked loop (PLL) at a maximum clock rate of 20.48 MHz. In its power saving operating modes, the MCU can be totally powered down, waking up only in response to an ADC conversion result ready, digital comparators, the wake-up timer, a POR, or an external serial communication event.

The ADC can be configured to operate in a normal (full power) mode of operation, interrupting the MCU after various sample conversion events. The current channel features two low power modes, low power and low power plus, generating conversion results to a lower performance specification.

On-chip factory firmware supports in-circuit Flash/EE reprogramming via the LIN or JTAG serial interface ports, and nonintrusive emulation is also supported via the JTAG interface. These features are incorporated into a low cost QuickStart™ development system supporting the ADuC7034.

The ADuC7034 operates directly from the 12 V battery supply and is fully specified over a temperature range of -40°C to $+115^{\circ}\text{C}$. The ADuC7034 is functional, but with degraded performance, at temperatures from 115°C to 125°C .

OVERVIEW OF THE ARM7TDMI CORE

The ARM7 core is a 32-bit, reduced instruction set computer (RISC), developed by ARM® Ltd. The ARM7TDMI is a von Neumann-based architecture, meaning that it uses a single 32-bit bus for instruction and data. The length of the data can

be 8, 16, or 32 bits and the length of the instruction word is either 16 bits or 32 bits, depending on the mode in which the core is operating.

The ARM7TDMI is an ARM7 core with four additional features, as listed in Table 8.

Table 8. ARM7TDMI

Feature	Description
T	Support for the Thumb® (16-bit) instruction set
D	Support for debug
M	Enhanced multiplier
I	Includes the EmbeddedICE™ module to support embedded system debugging

Thumb Mode (T)

An ARM instruction is 32 bits long. The ARM7TDMI processor supports a second instruction set compressed into 16 bits, the Thumb instruction set. Faster code execution from 16-bit memory and greater code density can be achieved by using the Thumb instruction set, making the ARM7TDMI core particularly suited for embedded applications.

However, the Thumb mode has three limitations.

- Relative to ARM, the Thumb code usually requires more instructions to perform that same task. Therefore, ARM code is best for maximizing the performance of time-critical code in most applications.
- The Thumb instruction set does not include some instructions that are needed for exception handling, so ARM code can be required for exception handling.
- When an interrupt occurs, the core vectors to the interrupt location in memory and executes the code present at that address. The first command is required to be in ARM code.

Multiplier (M)

The ARM7TDMI instruction set includes an enhanced multiplier, with four extra instructions to perform 32-bit by 32-bit multiplication with a 64-bit result, and 32-bit by 32-bit multiplication-accumulation (MAC) with a 64-bit result.

EmbeddedICE (I)

The EmbeddedICE module provides integrated on-chip debug support for the ARM7TDMI. The EmbeddedICE module contains the breakpoint and watchpoint registers that allow nonintrusive user code debugging. These registers are controlled through the JTAG test port. When a breakpoint or watchpoint is encountered, the processor halts and enters the debug state. Once in a debug state, the processor registers can be interrogated, as can the Flash/EE, SRAM, and memory mapped registers.

ARM7 Exceptions

The ARM7 supports five types of exceptions, with a privileged processing mode associated with each type. The five types of exceptions are as follows:

- Normal interrupt or IRQ. This is provided to service general-purpose interrupt handling of internal and external events.
- Fast interrupt or FIQ. This is provided to service data transfer or a communication channel with low latency. FIQ has priority over IRQ.
- Memory abort (prefetch and data).
- Attempted execution of an undefined instruction.
- Software interrupt (SWI) instruction that can be used to make a call to an operating system.

Typically, the programmer defines interrupts as IRQ, but for higher priority interrupts, the programmer can define interrupts as the FIQ type.

The priority of these exceptions and vector address are listed in Table 9.

Table 9. Exception Priorities and Vector Addresses

Priority	Exception	Address
1	Hardware Reset	0x00
2	Memory Abort (Data)	0x10
3	FIQ	0x1C
4	IRQ	0x18
5	Memory Abort (Prefetch)	0x0C
6	Software Interrupt ¹	0x08
6	Undefined Instruction ¹	0x04

¹ A software interrupt and an undefined instruction exception have the same priority and are mutually exclusive.

The list of exceptions in Table 9 are located from 0x00 to 0x1C, with a reserved location at 0x14. This location is required to be written with either 0x27011970 or the checksum of Page Zero, excluding location 0x14. If this is not done, user code does not execute and LIN download mode is entered.

ARM Registers

The ARM7TDMI has 16 standard registers. R0 to R12 are used for data manipulation, R13 is the stack pointer, R14 is the link register, and R15 is the program counter that indicates the instruction currently being executed. The link register contains the address from which the user has branched (if the branch and link command was used) or the command during which an exception occurred.

The stack pointer contains the current location of the stack. As a general rule, on an ARM7TDMI, the stack starts at the top of the available RAM area and descends using the area as required. A separate stack is defined for each of the exceptions. The size of each stack is user configurable and is dependent on the target application. On the ADuC7034, the stack begins at 0x00040FFC and descends. When programming using high level languages,

such as C, it is necessary to ensure that the stack does not overflow. This is dependent on the performance of the compiler that is used.

When an exception occurs, some of the standard registers are replaced with registers specific to the exception mode. All exception modes have replacement banked registers for the stack pointer (R13) and the link register (R14) as represented in Figure 11. The FIQ mode has more registers (R8 to R12) supporting faster interrupt processing. With the increased number of noncritical registers, the interrupt can be processed without the need to save or restore these registers, thereby reducing the response time of the interrupt handling process.

More information relative to the programmer’s model and the ARM7TDMI core architecture can be found in ARM7TDMI technical and ARM architecture manuals available directly from ARM Ltd.

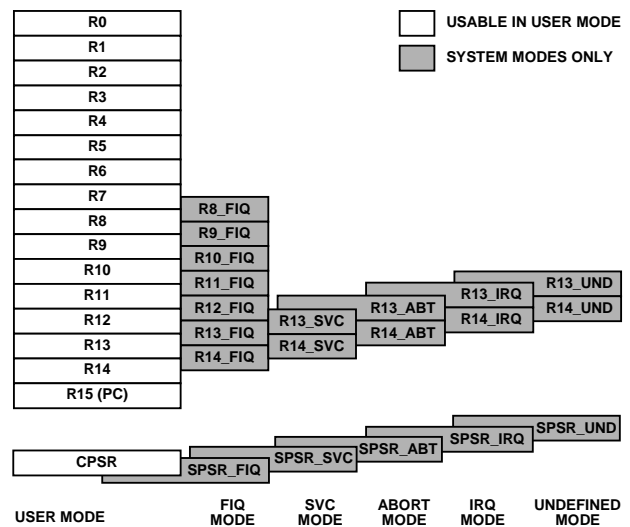

Figure 11. Register Organization

Interrupt Latency

The worst-case latency for an FIQ consists of the longest time the request can take to pass through the synchronizer, plus the time for the longest instruction to complete (the longest instruction is an LDM) that loads all the registers including the PC, plus the time for the data abort entry, plus the time for FIQ entry. At the end of this time, the ARM7TDMI is executing the instruction at 0x1C (FIQ interrupt vector address). The maximum total time is 50 processor cycles, or just over 2.44 μs in a system using a continuous 20.48 MHz processor clock. The maximum IRQ latency calculation is similar, but must allow for the fact that FIQ has higher priority and could delay entry into the IRQ handling routine for an arbitrary length of time. This time can be reduced to 42 cycles if the LDM command is not used; some compilers have an option to compile without using this command. Another option is to run the part in Thumb mode where this is reduced to 22 cycles.

The minimum latency for FIQ or IRQ interrupts is five cycles. This consists of the shortest time the request can take through the synchronizer plus the time to enter the exception mode.

Note that the ARM7TDMI initially (first instruction) runs in ARM (32-bit) mode when an exception occurs. The user can immediately switch from ARM mode to Thumb mode if required, for example, when executing interrupt service routines.

MEMORY ORGANIZATION

The ARM7, a von Neumann architecture, MCU core sees memory as a linear array of 2³² byte locations. As shown in Figure 13, the ADuC7034 maps this into four distinct user areas, namely: a memory area that can be remapped, an SRAM area, a Flash/EE area, and a memory mapped register (MMR) area.

- For the ADuC7034, the first 30 kB of this memory space is used as an area into which the on-chip Flash/EE or SRAM can be remapped.
- The ADuC7034 features a second 4-kB area at the top of the memory map used to locate the MMRs, through which all on-chip peripherals are configured and monitored.
- The ADuC7034 features a SRAM size of 4 kB.
- The ADuC7034 features 32 kB of on-chip Flash/EE memory. 30 kB of on-chip Flash/EE memory are available to the user. In addition, 2 kB are reserved for the on-chip kernel.

Any access, either reading or writing, to an area not defined in the memory map results in a data abort exception.

Memory Format

The ADuC7034 memory organization is configured in little endian format: the least significant byte is located in the lowest byte address and the most significant byte in the highest byte address.

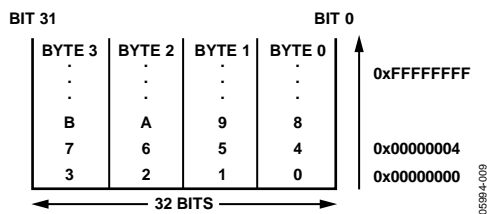

Figure 12. Little Endian Format

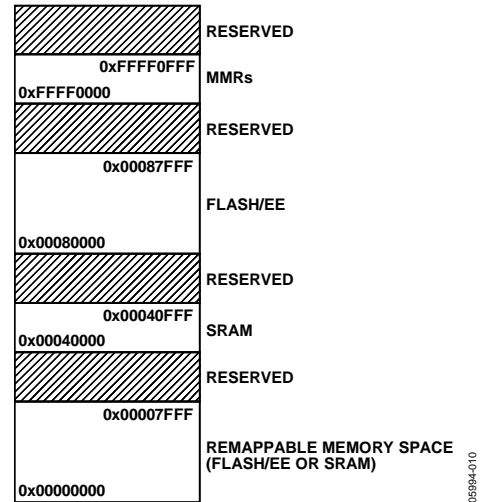

Figure 13. ADuC7034 Memory Map

SRAM

The ADuC7034 features 4 kB of SRAM, organized as 1024 × 32 bits, that is, 1024 words located at 0x40000.

The RAM space can be used as data memory and also as a volatile program space.

ARM code can run directly from SRAM at full clock speed given that the SRAM array is configured as a 32-bit wide memory array. SRAM is read/writeable in 8-, 16-, and 32-bit segments.

Remap

The ARM exception vectors are all situated at the bottom of the memory array, from Address 0x00000000 to Address 0x00000020.

By default, after a reset, the Flash/EE memory is logically mapped to Address 0x00000000.

It is possible to logically remap the SRAM to Address 0x00000000. This is accomplished by setting Bit 0 of the SYMAP0 MMR located at 0xFFFF0220. To revert Flash/EE to 0x00000000, Bit 0 of SYMAP0 is cleared.

It is sometimes desirable to remap RAM to 0x00000000 to optimize the interrupt latency of the ADuC7034 because code can run in full 32-bit ARM mode and at maximum core speed. It should be noted that when an exception occurs, the core defaults to ARM mode.

Remap Operation

When a reset occurs on the ADuC7034, execution starts automatically in the factory programmed internal configuration code. This so-called kernel is hidden and cannot be accessed by user code. If the ADuC7034 is in normal mode, it executes the power-on configuration routine of the kernel and then jumps to the reset vector, Address 0x00000000, to execute the user's reset exception routine. Since the Flash/EE is mirrored at the bottom

of the memory array at reset, the reset routine must always be written in Flash/EE.

The remap command must be executed from the absolute Flash/EE address, and not from the mirrored, remapped segment of memory, as this may be replaced by SRAM. If a remap operation is executed while operating code from the mirrored location, prefetch/data aborts can occur or the user can observe abnormal program operation.

Any kind of reset logically remaps the Flash/EE memory to the bottom of the memory array.

SYSMAP0 Register

Name:	SYSMAP0
Address:	0xFFFF0220
Default Value:	Updated by the kernel
Access:	Read/write access
Function:	This 8-bit register allows user code to remap either RAM or Flash/EE space into the bottom of the ARM memory space starting at Address 0x00000000.

Table 10. SYSMAP0 MMR Bit Designations

Bit	Description
7 to 1	Reserved. These bits are reserved and should be written as 0 by user code.
0	Remap Bit. Set by the user to remap the SRAM to 0x00000000. Cleared automatically after reset to remap the Flash/EE memory to 0x00000000.

RESET

There are four kinds of reset: external reset, power-on-reset, watchdog reset, and software reset. The RSTSTA register indicates the source of the last reset and can also be written by user code to initiate a software reset event. The bits in this register can be cleared to 0 by writing to the RSTCLR MMR at 0xFFFF0234. The bit designations in RSTCLR mirror those of RSTSTA. These registers can be used during a reset exception service routine to identify the source of the reset. The implications of all four kinds of reset event are tabulated in Table 12.

RSTSTA Register

Name: RSTSTA
Address: 0xFFFF0230
Default Value: Depends on type of reset
Access: Read/write access
Function: This 8-bit register indicates the source of the last reset event and can also be written by user code to initiate a software reset.

RSTCLR Register

Name: RSTCLR
Address: 0xFFFF0234
Access: Write Only
Function: This 8-bit write only register clears the corresponding bit in RSTSTA.

Table 11. RSTSTA/RSTCLR MMR Bit Designations

Bit	Description
7 to 4	Not Used. These bits are not used and always read as 0.
3	External Reset. Automatically set to 1 when an external reset occurs. This bit is cleared by setting the corresponding bit in RSTCLR.
2	Software Reset. This bit is set to 1 by user code to generate a software reset. This bit is cleared by setting the corresponding bit in RSTCLR. ¹
1	Watchdog Timeout. Automatically set to 1 when a watchdog timeout occurs. Cleared by setting the corresponding bit in RSTCLR.
0	Power-On Reset. Automatically Set when a power-on-reset occurs. Cleared by setting the corresponding bit in RSTCLR.

¹ If the software reset bit in RSTSTA is set, any write to RSTCLR that does not clear this bit generates a software reset.

Table 12. Device Reset Implications

RESET	Impact							
	Reset External Pins to Default State	Kernel Executed	Reset All External MMRs (Excluding RSTSTA)	Reset All HV Indirect Registers	Peripherals Reset	Watchdog Timer Reset	RAM Valid ¹	RSTSTA (Status After Reset Event)
POR	Yes	Yes	Yes	Yes	Yes	Yes	Yes/No ²	RSTSTA[0] = 1
Watchdog	Yes	Yes	Yes	Yes	Yes	No	Yes	RSTSTA[1] = 1
Software	Yes	Yes	Yes	Yes	Yes	No	Yes	RSTSTA[2] = 1
External Pin	Yes	Yes	Yes	Yes	Yes	No	Yes	RSTSTA[3] = 1

¹ RAM is not valid in the case of a reset following LIN download.

² The impact on RAM is dependent on the HVSTA[6] contents if LVF is enabled. When LVF is enabled using HVCFG0[2], RAM has not been corrupted by the POR reset mechanism if the LVF Status Bit HVSTA[6] is 1. See the Low Voltage Flag (LVF) section for more information.

FLASH/EE MEMORY

The ADuC7034 incorporates Flash/EE memory technology on-chip to provide the user with nonvolatile, in-circuit reprogrammable memory space.

Like EEPROM, Flash memory can be programmed in-system at a byte level, although it must first be erased, the erase being performed in page blocks. Thus, Flash memory is often and more correctly referred to as Flash/EE memory.

Overall, Flash/EE memory represents a step closer to the ideal memory device that includes nonvolatility, in-circuit programmability, high density, and low cost. Incorporated within the ADuC7034, Flash/EE memory technology allows the user to update program code space in-circuit, without the need to replace one time programmable (OTP) devices at remote operating nodes.

The Flash/EE memory is physically located at 0x80000. Upon a hard reset, it logically maps to 0x00000000. The factory default contents of all Flash/EE memory locations is 0xFF. Flash/EE can be read in 8-/16-/32-bit segments, and written in segments of 16 bits. The Flash/EE is rated for 10,000 endurance cycles. This rating is based on the number of times that each individual byte is cycled, that is, erased and programmed. Implementing a redundancy scheme in the software ensures a greater than 10,000-cycle endurance.

The user can also write data variables to the Flash/EE memory during run-time code execution, for example, for storing diagnostic battery parameter data.

The entire Flash/EE is available to the user as code and non-volatile data memory. There is no distinction between data and program, as ARM code shares the same space. The real width of the Flash/EE memory is 16 bits, meaning that in ARM mode (32-bit instruction), two accesses to the Flash/EE are necessary for each instruction fetch. When operating at speeds of less than 20.48 MHz, the Flash/EE memory controller can transparently fetch the second 16-bit halfword (part of the 32-bit ARM operation code) within a single core clock period. Therefore, it is recommended that for speeds less than 20.48 MHz, that is, $CD > 0$, use ARM mode. For 20.48MHz operation, that is, $CD = 0$, it is recommended to operate in Thumb mode.

The page size of this Flash/EE memory is 512 bytes. Typically, it takes the Flash/EE controller 20 ms to erase a page, regardless of CD. To write a 16-bit word at $CD = 0, 1, 2, 3$ requires 50 μ s; 70 μ s at $CD = 4, 5$; 80 μ s at $CD = 6$; and 105 μ s at $CD = 7$.

It is possible to write to a single, 16-bit location only twice between erases, that is, it is possible to walk bytes, not bits.

If a location is written to more than twice, then it is possible to corrupt the contents of the Flash/EE page.

The Flash/EE memory can be programmed in-circuit, using a serial download mode via the LIN interface or the integrated JTAG port.

Serial Downloading (In-Circuit Programming)

The ADuC7034 facilitates code download via the LIN pin.

JTAG Access

The ADuC7034 features an on-chip JTAG debug port to facilitate code download and debug.

ADuC7034 Flash/EE Memory

The total 32 kB of Flash/EE are organized as $15,000 \times 16$ bits. 30 kB are user space and 2 kB are reserved for boot loader/kernel space.

FLASH/EE CONTROL INTERFACE

The access to, and control of, the Flash/EE memory on the ADuC7034 is managed by an on-chip memory controller. The controller manages the Flash/EE memory as a single block of 32 kB.

It should be noted that the MCU core is halted until the command is completed. User software must ensure that the Flash/EE controller has completed any erase or write cycle before the PLL is powered down. If the PLL is powered down before an erase or write cycle is completed, the Flash/EE page can be corrupted. User code, LIN, and JTAG programming use the Flash/EE control interface, consisting of the following MMRs:

- FEE0STA—read only register, reflects the status of the Flash/EE control interface.
- FEE0MOD—sets the operating mode of the Flash/EE control interface.
- FEE0CON—8-bit command register. The commands are interpreted as described in Table 13.
- FEE0DAT—16-bit data register.
- FEE0ADR—16-bit address register.
- FEE0SIG—holds the 24-bit code signature as a result of the signature command being initiated.
- FEE0HID—protection MMR. Controls read and write protection of the Flash/EE memory code space. If previously configured via the FEE0PRO register, FEE0HID can require a software key to enable access.
- FEE0PRO—a buffer of the FEE0HID register that stores the FEE0HID value, thus, it automatically downloads to the FEE0HID registers on subsequent reset and power-on events.

The following sections provide detailed descriptions of the bit designations for each of the Flash/EE control MMRs.

FEE0CON Register

- Name:** FEE0CON
- Address:** 0xFFFF0E08
- Default Value:** 0x07
- Access:** Read/write access
- Function:** This 8-bit register is written by user code to control the operating modes of the Flash/EE memory controller.

Table 13. Command Codes in FEE0CON

Code	Command	Description
0x00 ¹	Reserved	Reserved, this command should not be written by user code.
0x01 ¹	Single read	Load FEE0DAT with the 16-bit data indexed by FEE0ADR.
0x02 ¹	Single write	Write FEE0DAT at the address pointed by FEE0ADR. This operation takes 50 μs.
0x03 ¹	Erase write	Erase the page indexed by FEE0ADR and write FEE0DAT at the location pointed by FEE0ADR. This operation takes 20 ms.
0x04 ¹	Single verify	Compare the contents of the location pointed by FEE0ADR to the data in FEE0DAT. The result of the comparison is returned in FEE0STA Bit 1.
0x05 ¹	Single erase	Erase the page indexed by FEE0ADR.
0x06 ¹	Mass erase	Erase 30 kB of user space. The 2 kB kernel is protected. This operation takes 1.2 seconds. To prevent accidental execution, a command sequence is required to execute this instruction, this is described in the Command Sequence for Executing a Mass Erase section.
0x07	Idle	Default command.
0x08	Reserved	Reserved, this command should not be written by user code.
0x09	Reserved	Reserved, this command should not be written by user code.
0x0A	Reserved	Reserved, this command should not be written by user code.
0x0B	Signature	This command results in a 24-bit, LFSR-based signature being generated and loaded into FEE0SIG. If FEE0ADR is less than 0x87800, this command results in a 24-bit LFSR-based signature of the user code space from the page specified in FEE0ADR upwards, including the kernel, security bits, and Flash/EE key. If FEE0ADR is greater than 0x87800, the kernel and manufacturing data is signed. This operation takes 120 μs.
0x0C	Protect	This command can be run one time only. The value of FEE0PRO is saved and can be removed only with a mass erase (0x06) or with the software protection key.
0x0D	Reserved	Reserved, this command should not be written by user code.
0x0E	Reserved	Reserved, this command should not be written by user code.
0x0F	Ping	No operation, interrupt generated.

¹ The FEE0CON always reads 0x07 immediately after execution of any of these commands.

Command Sequence for Executing a Mass Erase

Given the significance of the mass erase command, a specific code sequence must be executed to initiate this operation.

1. Set Bit 3 in FEE0MOD.
2. Write 0xFFC3 in FEE0ADR.
3. Write 0x3CFF in FEE0DAT.
4. Run the Mass Erase Command 0x06 in FEE0CON.

This sequence is illustrated in the following example:

```
FEE0MOD = 0x08
FEE0ADR = 0xFFC3
FEE0DAT = 0x3CFF
FEE0CON = 0x06;           //Mass Erase command
while (FEE0STA & 0x04){} //Wait for command to finish
```

FEE0STA Register

Name: FEE0STA

Address: 0xFFFF0E00

Default Value: 0x20

Access: Read only

Function: This 8-bit, read only register can be read by user code and reflects the current status of the Flash/EE memory controller.

Table 14. FEE0STA MMR Bit Designation

Bit	Description
15 to 4	Not Used. These bits are not used and always read as 0.
3	Flash/EE Interrupt Status Bit. Set automatically when an interrupt occurs, that is, when a command is complete and the Flash/EE interrupt enable bit in the FEE0MOD register is set. Cleared automatically when the FEE0STA register is read by user code.
2	Flash/EE Controller Busy. Set automatically when the Flash/EE controller is busy. Cleared automatically when the controller is not busy.
1	Command Fail. Set automatically when a command written to FEE0CON completes unsuccessfully. Cleared automatically when the FEE0STA register is read by user code.
0	Command Successful. Set automatically by MCU when a command is completed successfully. Cleared automatically when the FEE0STA register is read by user code.

FEE0MOD Register

Name: FEE0MOD

Address: 0xFFFF0E04

Default Value: 0x00

Access: Read/write access

Function: This register is written by user code to configure the mode of operation of the Flash/EE memory controller.

Table 15. FEE0MOD MMR Bit Designation

Bit	Description
15 to 7	Not Used. These bits are reserved for future functionality and should be written as 0 by user code.
6, 5	Flash/EE Security Lock Bits. These bits must be written as [6, 5] = 1,0 to complete the Flash/EE security protect sequence.
4	Flash/EE Controller Command Complete Interrupt Enable. This bit is set to 1 by user code to enable the Flash/EE controller to generate an interrupt upon completion of a Flash/EE command. This bit is cleared to disable the generation of a Flash/EE interrupt upon completion of a Flash/EE command.
3	Flash/EE Erase/Write Enable. Set by user code to enable the Flash/EE erase and write access via FEE0CON. Cleared by user code to disable the Flash/EE erase and write access via FEE0CON.
2	Reserved.
1	Flash/EE Controller Abort Enable. This bit is set to 1 by user code to enable the Flash/EE controller abort functionality.
0	Reserved.

FEE0ADR Registers

Name: FEE0ADR

Address: 0xFFFF0E10

Default Value: Non zero, see the System Identification FEE0ADR section

Access: Read/write access

Function: This 16-bit register dictates the address upon which any Flash/EE command executed via FEE0CON acts.

FEE0DAT Registers

Name: FEE0DAT

Address: 0xFFFF0E0C

Default Value: 0x0000

Access: Read/write access

Function: This 16-bit register contains the data either read from, or to be written to, the Flash/EE memory.

FLASH/EE MEMORY SECURITY

The 30 kB of Flash/EE memory available to the user can be read and write protected using the FEE0HID register.

The FEE0HID MMR protects the 30 kB of Flash/EE memory. Bits[0:28] of this register protect Page 0 to Page 57 from writing. Each bit protects two pages, that is, 1 kB. Bit 29 to Bit 30 protect Page 58 and Page 59, respectively; that is, each bit write protects a single page of 512 bytes. The MSB of this register (Bit 31) protects the entire Flash/EE from being read through JTAG.

The FEE0PRO register mirrors the bit definitions of the FEE0HID MMR. The FEE0PRO MMR allows user code to lock the protection or security configuration of the Flash/EE memory so that the protection configuration is automatically loaded on subsequent power-on or reset events. This flexibility allows the user to temporarily set and test protection settings using the FEE0HID MMR and, subsequently, lock the required protection configuration (using FEE0PRO) when shipping protection systems into the field.

Flash/EE Memory Protection Registers

Name: FEE0HID and FEE0PRO

Address: 0xFFFF0E20 (for FEE0HID) and 0xFFFF0E1C (for FEE0PRO)

Default Value: 0xFFFFFFFF (for FEE0HID) and 0x00000000 (for FEE0PRO)

Access: Read/write access

Function: These registers are written by user code to configure the protection of the Flash/EE memory.

Table 16. FEE0HID and FEE0PRO MMR Bit Designations

Bit	Description
31	Read Protection. Cleared by user to read protect the 32-kB Flash/EE block code. Set by user to allow read access to the 32-kB Flash/EE block via JTAG.
30	Write Protection Bit. This bit is set by user code to unprotect Page 59. This bit is cleared by user code write protect Page 59.
29	Write Protection Bit. This bit is set by user code to unprotect Page 58. This bit is cleared by user code write protect Page 58.
28 to 0	Write Protection Bits. When set by user code, these bits unprotect Page 0 to Page 57 of the 30-kB Flash/EE code memory. Each bit write protects two pages and each page consists of 512 bytes. When cleared by user code, these bits write protect Page 0 to Page 57 of the 30-kB Flash/EE code memory. Each bit write protects two pages and each page consists of 512 bytes.

In summary, there are three levels of protection as follows:

Temporary Protection

Temporary protection can be set and removed by writing directly into FEE0HID MMR. This register is volatile and, therefore, protection is only in place for as long as the part remains powered on. This protection is not reloaded after a power cycle.

Keyed Permanent Protection

Keyed permanent protection can be set via FEE0PRO to lock the protection configuration. The software key used at the start of the required FEE0PRO write sequence is saved one time only, and must be used for any subsequent access of the FEE0HID or FEE0PRO MMRs. A mass erase sets the software protection key back to 0xFFFF but also erases the entire user code space.

Permanent Protection

Permanent protection can be set via FEE0PRO, similarly to keyed permanent protection, the only difference being that the software key used is 0xDEADDEAD. When the FEE0PRO write sequence is saved, only a mass erase sets the software protection key back to 0xFFFFFFFF. This also erases the entire user code space.

Sequence to Write the Software Protection Key and Set Permanent Protection

1. Write in FEE0PRO corresponding to the pages to be protected.
2. Write the new (user defined) 32-bit software protection key in FEE0ADR (Bits[31:16]) and FEE0DAT (Bits[15:0]).
3. Write 1,0 in FEE0MOD (Bits[6:5]) and set FEE0MOD (Bit 3).
4. Run the Write Key Command 0x0C in FEE0CON.

To remove or modify the protection, the same sequence can be used with a modified value of FEE0PRO.

The previous sequence for writing the key and setting permanent protection is illustrated in the following example, this protects writing Page 4 and Page 5 of the Flash/EE:

```

Int a = FEE0STA;           // Ensure FEE0STA is cleared
FEE0PRO = 0xFFFFFFFFB;    // Protect Page 4 and Page 5
FEE0ADR = 0x66BB;         // 32-bit key value (Bits [31:16])
FEE0DAT = 0xAA55;         // 32-bit key value (Bits 15:0)
FEE0MOD = 0x0048          // Lock security sequence
FEE0CON = 0x0C;           // Write key command
while (FEE0STA & 0x04){}  // Wait for command to finish
    
```

FLASH/EE MEMORY RELIABILITY

The Flash/EE memory array on the part is fully qualified for two key Flash/EE memory characteristics: Flash/EE memory cycling endurance and Flash/EE memory data retention.

Endurance quantifies the ability of the Flash/EE memory to be cycled through many program, read, and erase cycles. A single endurance cycle is composed of four independent, sequential events, defined as

- Initial page erase sequence.
- Read/verify sequence.
- Byte program sequence.
- Second read/verify sequence.

In reliability qualification, every halfword (16-bit wide) location of the three pages (top, middle, and bottom) in the Flash/EE memory is cycled 10,000 times from 0x0000 to 0xFFFF. As indicated in Table 1, the Flash/EE memory endurance qualification of the part is carried out in accordance with JEDEC Retention Lifetime Specification A117. The results allow the specification of a minimum endurance figure over supply and temperature of 10,000 cycles.

Retention quantifies the ability of the Flash/EE memory to retain its programmed data over time. Again, the part is qualified in accordance with the formal JEDEC Retention Lifetime Specification A117 at a specific junction temperature ($T_j = 85^\circ\text{C}$). As part of this qualification procedure, the Flash/EE memory is cycled to its specified endurance limit, described previously, before data retention is characterized. This means that the Flash/EE memory is guaranteed to retain its data for its fully specified retention lifetime every time the Flash/EE memory is reprogrammed. Also note that retention lifetime, based on an activation energy of 0.6 eV derates with T_j as shown in Figure 14.

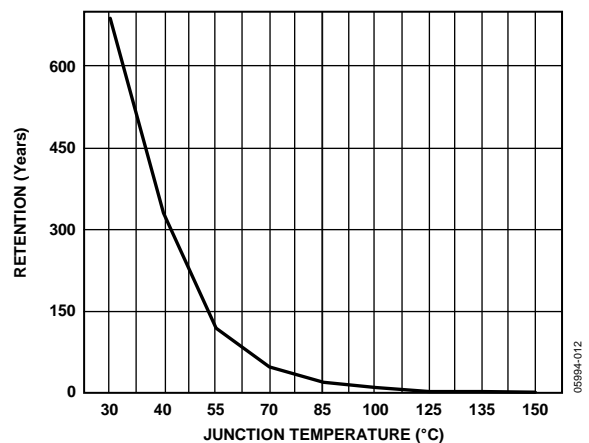

Figure 14. Flash/EE Memory Data Retention

CODE EXECUTION TIME FROM SRAM AND FLASH/EE

This section describes SRAM and Flash/EE access times during execution for applications where execution time is critical.

Execution from SRAM

Fetching instructions from SRAM takes one clock cycle because the access time of the SRAM is 2 ns, and a clock cycle is 49 ns minimum. However, if the instruction involves reading or writing data to memory, one extra cycle must be added if the data is in SRAM. If the data is in Flash/EE, two cycles must be added: one cycle to execute the instruction and two cycles to retrieve the 32-bit data from Flash/EE. A control flow instruction (for example, a branch instruction) takes one cycle to fetch and two cycles to fill the pipeline with the new instructions.

Execution from Flash/EE

In Thumb mode, where instructions are 16 bits, one cycle is needed to fetch any instruction.

In ARM mode, with $CD = 0$, two cycles are needed to fetch the 32-bit instructions. With $CD > 0$, no extra cycles are required for the fetch because the Flash/EE memory continues to be clocked at full speed. In addition, some dead time is needed before accessing data for any value of CD bits.

Timing is identical in both modes when executing instructions that involve using the Flash/EE for data memory. If the instruction to be executed is a control flow instruction, an extra cycle is needed to decode the new address of the program counter, and then four cycles are needed to fill the pipeline if $CD = 0$.

A data processing instruction involving only core register does not require any extra clock cycles. Data transfer instructions are more complex and are summarized in Table 17.

Table 17. Typical Execution Cycles in ARM/Thumb Mode

Instructions	Fetch Cycles	Dead Time	Data Access
LD	2/1	1	2
LDH	2/1	1	1
LDM/PUSH	2/1	N	$2 \times N$
STR	2/1	1	$2 \times 50 \mu\text{s}$
STRH	2/1	1	$50 \mu\text{s}$
STRM/POP	2/1	N	$2 \times N \times 50 \mu\text{s}$

With $1 < N \leq 16$, N = the number of data to load or store in the multiple load/store instruction.

By default, Flash/EE code execution is suspended during any Flash/EE erase or write cycle. A page (512 bytes) erase cycle takes 20 ms and a write (16 bits) word command takes $50 \mu\text{s}$. However, the Flash/EE controller allows erase/write cycles to be aborted if the ARM core receives an enabled interrupt during the current Flash/EE erase/write cycle. The ARM7 can therefore immediately service the interrupt and then return to repeat the Flash/EE command. The abort operation typically takes 10 clock cycles. If the abort operation is not feasible, it is possible to run Flash/EE programming code and the relevant interrupt routines from SRAM, allowing the core to immediately service the interrupt.

ADUC7034 KERNEL

The ADuC7034 features an on-chip kernel resident in the top 2 kB of the Flash/EE code space. After any reset event, this kernel copies the factory calibrated data from the manufacturing data space into the various on-chip peripherals. The peripherals calibrated by the kernel are as follows:

- Power supply monitor (PSM)
- Precision oscillator
- Low power oscillator
- REG_AVDD/REG_DVDD
- Low power voltage reference
- Normal mode voltage reference
- Current ADC (offset and gain)
- Voltage/temperature ADC (offset and gain)

User MMRs that can be modified by the kernel and differ from their POR default values are as follows:

- R0 to R15
- GP0CON/GP2CON
- SYSCHK
- ADCMDE/ADC0CON
- FEE0ADR/FEE0CON/FEE0SIG
- HV DAT/HVCON
- HVCFG0/HVCFG1
- T3LD

The ADuC7034 also features an on-chip LIN downloader.

A flow chart of the execution of the kernel is shown in Figure 15. The current revision of the kernel can be derived from SYSSER1, as described in Table 98.

For the duration of the kernel execution, the watchdog timer is active with a timeout period of 30 ms. This ensures that when an error occurs in the kernel, the ADuC7034 automatically resets. After a POR reset, the watchdog timer is disabled once the kernel code is exited. After any other reset, the watchdog timer maintains user code configuration for the period of the kernel, and is refreshed just prior to kernel exit. A minimum watchdog period of 30 ms is required. If LIN download mode is entered, the watchdog is periodically refreshed.

Normal kernel execution time, excluding LIN download, is approximately 5 ms. It is only possible to enter and leave LIN download mode through a reset.

SRAM is not modified during normal kernel execution; rather, SRAM is modified during a LIN download kernel execution.

Note that even with NTRST = 0, user code is not executed unless Address 0x14 contains either 0x27011970 or the checksum of Page 0, excluding Address 0x14. If Address 0x14 does not contain this information, user code is not executed and LIN download mode is entered.

With NTRST = 1, user code is always executed.

During kernel execution, JTAG access is disabled.

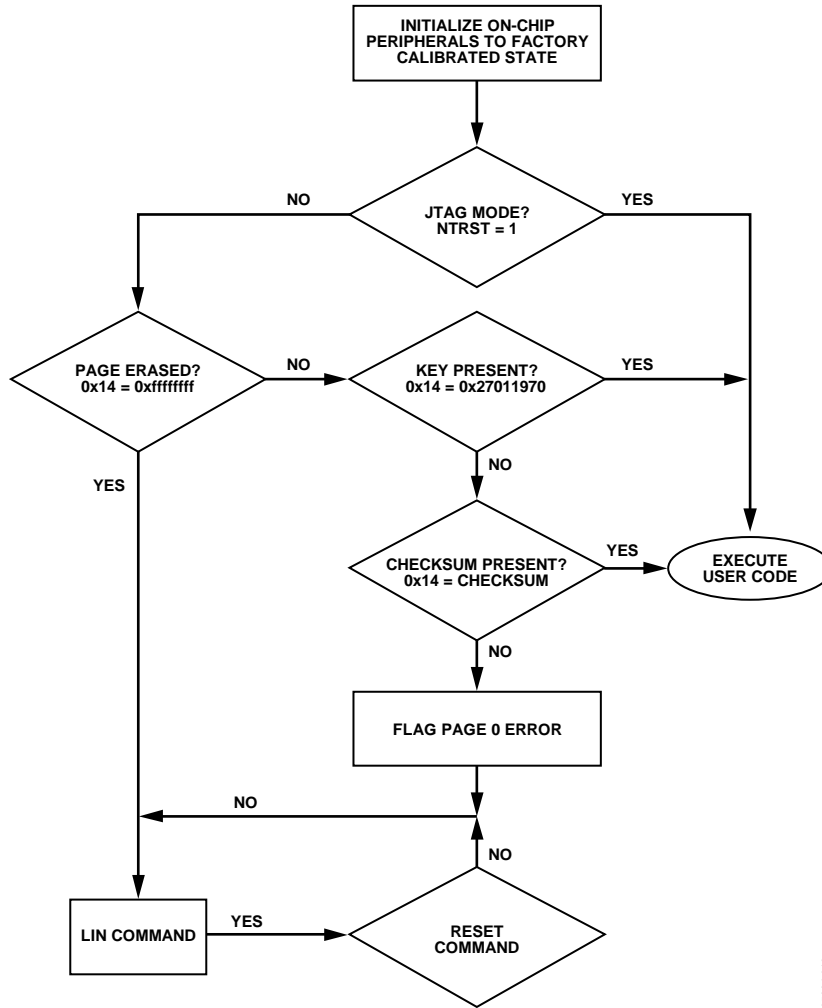

Figure 15. ADuC7034 Kernel Flowchart

05694-013

MEMORY MAPPED REGISTERS

The memory mapped register (MMR) space is mapped into the top 4 kB of the MCU memory space and accessed by indirect addressing, load, and store commands through the ARM7 banked registers. An outline of the memory mapped register bank for the ADuC7034 is shown in Figure 16.

The MMR space provides an interface between the CPU and all on-chip peripherals. All registers except the ARM7 core registers (described in the ARM Registers section) reside in the MMR area.

As shown in the detailed MMR maps in the Complete MMR Listing (Table 18 to Table 29), the MMR data widths vary from 1 byte (8 bits) to 4 bytes (32 bits). The ARM7 core can access any of the MMRs (single byte or multiple byte width registers) with a 32-bit read or write access.

The resultant read, for example, is aligned per little endian format as previously described in this data sheet. However, errors result if the ARM7 core tries to access 4-byte (32-bit) MMRs with a 16-bit access. In the case of a (16-bit) write access to a 32-bit MMR, the (upper) 16 most significant bits are written as 0s. More obviously, in the case of a 16-bit read access to a 32-bit MMR, only 16 of the MMR bits can be read.

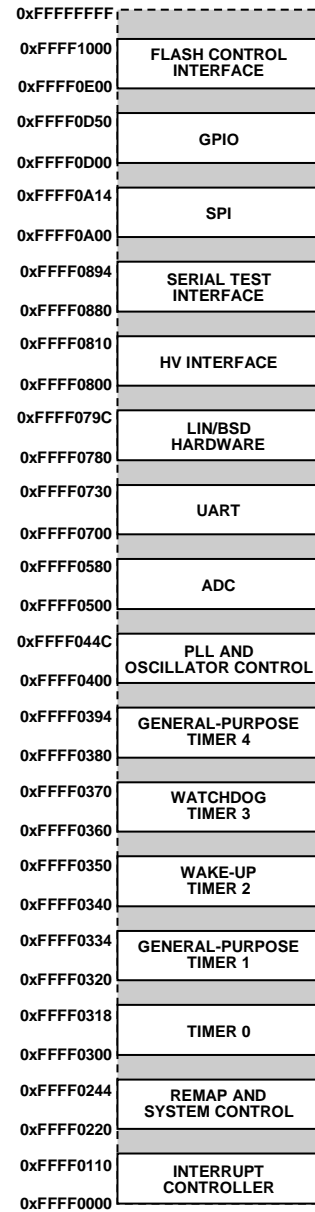

Figure 16. Top Level MMR Map

05984-01-4

COMPLETE MMR LISTING

In the following MMR tables, addresses are listed in hex code. Access types include R for read, W for write, and RW for read and write.

Table 18. IRQ Address Base = 0xFFFF0000

Address	Name	Byte	Access Type	Default Value	Description
0x0000	IRQSTA	4	R	0x00000000	Active IRQ Source. See the Interrupt System section and Table 49.
0x0004	IRQSIG ¹	4	R		Current State of All IRQ Sources (Enabled and Disabled). See the Interrupt System section and Table 49.
0x0008	IRQEN	4	RW	0x00000000	Enabled IRQ Sources. See the Interrupt System section and Table 49.
0x000C	IRQCLR	4	W		MMR to Disable IRQ Sources. See the Interrupt System section and Table 49.
0x0010	SWICFG	4	W		Software Interrupt Configuration MMR. See the Programmed Interrupts section and Table 50.
0x0100	FIQSTA	4	R	0x00000000	Active IRQ Source. See the Interrupt System section and Table 49.
0x0104	FIQSIG ¹	4	R		Current State of All IRQ Sources (Enabled and Disabled). See the Interrupt System section and Table 49.
0x0108	FIQEN	4	RW	0x00000000	Enabled IRQ Sources. See the Interrupt System section and Table 49.
0x010C	FIQCLR	4	W		MMR to Disable IRQ Sources. See the Interrupt System section and Table 49.

¹ Depends on the level on the external interrupt pins (GP0, GP5, GP7, and GP8).

Table 19. System Control Address Base = 0xFFFF0200

Address	Name	Byte	Access Type	Default Value	Description
0x0220	SYMAP0	1	RW	N/A	REMAP Control Register. See the Remap Operation section and Table 10.
0x0230	RSTSTA	1	RW	N/A	Reset Status MMR. See the Reset section and Table 11 and Table 12.
0x0234	RSTCLR	1	W	N/A	RSTSTA Clear MMR. See the Reset section and Table 11 and Table 12.
0x0238	SYSSER0 ¹	4	RW	N/A	System Serial Number 0. See the Part Identification section and Table 97 for details.
0x023C	SYSSER1 ¹	4	RW	N/A	System Serial Number 1. See the Part Identification section and Table 97 for details.
0x0560	SYSALI ¹	4	R	N/A	System Assembly Lot ID, See the Part Identification section for details.
0x0240	SYSCHK ¹	4	RW	N/A	Kernel Checksum. See the System Kernel Checksum section.

¹ Updated by kernel.

Table 20. Timer Address Base = 0xFFFF0300

Address	Name	Byte	Access Type	Default Value	Description
0x0300	TOLD	2	RW	0x0000	Timer0 Load Register. See the Timer0—Lifetime Timer and Timer0 Load Registers sections.
0x0304	TOVAL0	2	R	0x0000	Timer0 Value Register 0. See the Timer0—Lifetime Timer and Timer0 Value Registers (TOVAL0/TOVAL1) sections.
0x0308	TOVAL1	4	R	0x00000000	Timer0 Value Register 1. See the Timer0—Lifetime Timer and Timer0 Value Registers (TOVAL0/TOVAL1) sections.
0x030C	T0CON	4	RW	0x00000000	Timer0 Control MMR. See the Timer0—Lifetime Timer and Timer0 Control Register sections.
0x0310	TOCLRI	1	W	N/A	Timer0 Interrupt Clear Register. See the Timer0—Lifetime Timer and Timer0 Clear Register sections.
0x0314	TOCAP	2	RW	0x0000	Timer0 Capture Register. See the Timer0—Lifetime Timer and Timer0 Capture Register sections.
0x0320	T1LD	4	RW	0x00000000	Timer1 Load Register. See the Timer1 and Timer1 Load Registers sections.
0x0324	T1VAL	4	R	0xFFFFFFFF	Timer1 Value Register. See the Timer1 and Timer1 Value Register sections.
0x0328	T1CON	4	RW	0x01000000	Timer1 Control MMR. See the Timer1 and Timer1 Control Register sections.
0x032C	T1CLRI	1	W	N/A	Timer1 Interrupt Clear Register. See the Timer1 and Timer1 Clear Register sections.
0x0330	T1CAP	4	R	0x00000000	Timer1 Capture Register. See the Timer1 and Timer1 Capture Register sections.

Address	Name	Byte	Access Type	Default Value	Description
0x0340	T2LD	4	RW	0x00000000	Timer2 Load Register. See the Timer2 or Wake-Up Timer and Timer2 Load Register sections.
0x0344	T2VAL	4	R	0xFFFFFFFF	Timer2 Value Register. See the Timer2 or Wake-Up Timer and Timer2 Value Register sections.
0x0348	T2CON	2	RW	0x0000	Timer2 Control MMR. See the Timer2 or Wake-Up Timer and Timer2 Control Register sections and Table 54.
0x034C	T2CLRI	1	W	N/A	Timer2 Interrupt Clear Register. See the Timer2 or Wake-Up Timer and Timer2 Clear Register sections.
0x0360	T3LD	2	RW	0x0040	Timer3 Load Register. See the Timer3 or Watchdog Timer and Timer3 Load Register sections.
0x0364	T3VAL	2	R	0x0040	Timer3 Value Register. See the Timer3 or Watchdog Timer and Timer3 Value Register sections.
0x0368	T3CON	2	RW	0x0000	Timer3 Control MMR. See the Timer3 or Watchdog Timer, Timer3 Value Register, and Timer3 Control Register sections and Table 55.
0x036C	T3CLRI ¹	1	W	N/A	Timer3 Interrupt Clear Register. See the Timer3 or Watchdog Timer and Timer3 Clear Register sections.
0x0380	T4LD	2	RW	0x0000	Timer4 Load Register. See the Timer4 or STI Timer and Timer4 Load Register sections.
0x0384	T4VAL	2	R	0xFFFF	Timer4 Value Register. See the Timer4 or STI Timer and Timer4 Value Register sections.
0x0388	T4CON	4	RW	0x00000000	Timer4 Control MMR. See the Timer4 or STI Timer and Timer4 Control Register sections and Table 56.
0x038C	T4CLRI	1	W	N/A	Timer4 Interrupt Clear Register. See the Timer4 or STI Timer and Timer4 Clear Register sections.
0x0390	T4CAP	2	R	0x0000	Timer4 Capture Register. See the Timer4 or STI Timer section and Table 56.

¹ Updated by kernel.

Table 21. PLL Base Address = 0xFFFF0400

Address	Name	Byte	Access Type	Default Value	Description
0x0400	PLLSTA	4	R	N/A	PLL Status MMR. See the PLLSTA Register section.
0x0404	POWKEY0	4	W	N/A	POWCON Prewrite Key. See the POWCON Prewrite Key POWKEY0 section.
0x0408	POWCON	1	RW	0x79	Power Control and Core Speed Control Register. See the POWCON Register section.
0x040C	POWKEY1	4	W	N/A	POWCON Postwrite Key. See the POWCON Postwrite Key POWKEY1 section.
0x0410	PLLKEY0	4	W	N/A	PLLCON Prewrite Key. See the PLLCON Prewrite Key PLLKEY0 section.
0x0414	PLLCON	1	RW	0x00	PLL Clock Source Selection MMR. See the PLLCON Register section.
0x0418	PLLKEY1	4	W	N/A	PLLCON Postwrite Key. See the PLLCON Postwrite Key PLLKEY1 section.
0x042C	OSCOTRM	1	RW	0xX8	Low Power Oscillator Trim Bits MMR. See the OSCOTRM Register section.
0x0440	OSCOCON	1	RW	0x00	Low Power Oscillator Calibration Control MMR. See the OSCOCON Register section.
0x0444	OSCOSTA	1	R	0x00	Low Power Oscillator Calibration Status MMR. See the OSCOSTA Register section.
0x0448	OSCOVAL0	2	R	0x0000	Low Power Oscillator Calibration Counter 0 MMR. See the OSCOVAL0 Register section.
0x044C	OSCOVAL1	2	R	0x0000	Low Power Oscillator Calibration Counter 1 MMR. See the OSCOVAL1 Register section.

Table 22. ADC Address Base = 0xFFFF0500

Address	Name	Byte	Access Type	Default Value	Description
0x0500	ADCSTA	2	R	0x0000	ADC Status MMR. See the ADC Status Register section and Table 34.
0x0504	ADCMSKI	1	RW	0x00	ADC Interrupt Source Enable MMR. See the ADC Interrupt Mask Register section.
0x0508	ADCMDE	1	RW	0x00	ADC Mode Register. See the ADC Mode Register section and Table 35.
0x050C	ADC0CON	2	RW	0x0000	Current ADC Control MMR. See the Current Channel ADC Control Register section and Table 36.
0x0510	ADC1CON	2	RW	0x0000	V/T ADC Control MMR. See the Voltage/Temperature Channel ADC Control Register section and Table 37.
0x0518	ADCFLT	2	RW	0x0007	ADC Filter Control MMR. See the ADC Filter Register section and Table 38.
0x051C	ADCCFG	1	RW	0x00	ADC Configuration MMR. See the ADC Configuration Register section and Table 41.
0x0520	ADC0DAT	2	R	0x0000	Current ADC Result MMR. See the Current Channel ADC Data Register section.
0x0524	ADC1DAT	2	R	0x0000	V ADC Result MMR. See the Voltage Channel ADC Data Register section.
0x0528	ADC2DAT	2	R	0x0000	T ADC Result MMR. See the Temperature Channel ADC Data Register section.
0x0530	ADC0OF ¹	2	RW	N/A	Current ADC Offset MMR. See the Current Channel ADC Offset Calibration Register section.
0x0534	ADC1OF ¹	2	RW	N/A	Voltage ADC Offset MMR. See the Voltage Channel ADC Offset Calibration Register section.
0x0538	ADC2OF ¹	2	RW	N/A	Temperature ADC Offset MMR. See the Temperature Channel ADC Offset Calibration Register section.
0x053C	ADC0GN ¹	2	RW	N/A	Current ADC Gain MMR. See the Current Channel ADC Gain Calibration Register section.
0x0540	ADC1GN ¹	2	RW	N/A	Voltage ADC Gain MMR. See the Voltage Channel Gain Calibration Register section.
0x0544	ADC2GN ¹	2	RW	N/A	Temperature ADC Gain MMR. See the Temperature Channel Gain Calibration Register section.
0x0548	ADC0RCL	2	RW	0x0001	Current ADC Result Count Limit. See the Current Channel ADC Result Counter Limit Register section.
0x054C	ADC0RCV	2	R	0x0000	Current ADC Result Count Value. See the Current Channel ADC Result Count Register section.
0x0550	ADC0TH	2	RW	0x0000	Current ADC Result Threshold. See the Current Channel ADC Threshold Register section.
0x0554	ADC0TCL	1	RW	0x01	Current ADC Result Threshold Count Limit. See the Current Channel ADC Threshold Count Limit Register section.
0x0558	ADC0THV	1	R	0x00	Current ADC Result Threshold Count Limit Value. See the Current Channel ADC Threshold Count Register section.
0x055C	ADC0ACC	4	R	0x00000000	Current ADC Result Accumulator. See the Current Channel ADC Accumulator Register section.
0x057C	ADCREF ¹	2	RW	N/A	Low Power Mode Voltage Reference Scaling Factor. See the Low Power Voltage Reference Scaling Factor section.

¹ Updated by kernel.

Table 23. UART Base Address = 0XFFFF0700

Address	Name	Byte	Access Type	Default Value	Description
0x0700	COMTX	1	W	N/A	UART Transmit Register. See the UART TX Register section.
	COMRX	1	R	0x00	UART Receive Register. See the UART RX Register section.
	COMDIV0	1	RW	0x00	UART Standard Baud Rate Generator Divisor Value 0. See the UART Divisor Latch Register 0 section.
0x0704	COMIEN0	1	RW	0x00	UART Interrupt Enable MMR 0. See the UART Interrupt Enable Register 0 section and Table 83.
	COMDIV1	1	R/W	0x00	UART Standard Baud Rate Generator Divisor Value 1. See the UART Divisor Latch Register 1 section.
0x0708	COMIID0	1	R	0x01	UART Interrupt Identification 0. See the UART Interrupt Identification Register 0 section and Table 84.
0x070C	COMCON0	1	RW	0x00	UART Control Register 0. See the UART Control Register 0 section and Table 80.
0x0710	COMCON1	1	RW	0x00	UART Control Register 1. See the UART Control Register 1 section and Table 81.
0x0714	COMSTA0	1	R	0x60	UART Status Register 0. See the UART Status Register 0 section and Table 82.
0X072C	COMDIV2	2	RW	0x0000	UART Fractional Divider MMR. See the UART Fractional Divider Register section and Table 85.

Table 24. LIN Hardware Sync Base Address = 0XFFFF0780

Address	Name	Byte	Access Type	Default Value	Description
0x0780	LHSSTA	1	R	0x00	LHS Status MMR. See the LIN Hardware Synchronization Status Register section and Table 91.
0x0784	LHSCON0	2	R/W	0x0000	LHS Control MMR 0. See the LIN Hardware Synchronization Control Register 0 section and Table 92.
0x0788	LHSVAL0	2	R/W	0x0000	LHS Timer0 MMR. See the LIN Hardware Synchronization Timer0 Register section.
0x078C	LHSCON1	1	R/W	0x32	LHS Control MMR 1. See the LIN Hardware Synchronization Control Register 1 section and Table 93.
0x0790	LHSVAL1	2	R/W	0x0000	LHS Timer1 MMR. See the LIN Hardware Break Timer1 Register section.
0x0794	LHSCAP	1	R	0x0000	LHS Capture MMR. See the LIN Hardware Synchronization Capture Register section.
0x0798	LHSCMP	2	R/W	0x0000	LHS Compare MMR. See the LIN Hardware Synchronization Compare Register section.

Table 25. High Voltage Interface Base Address = 0xFFFF0800

Address	Name	Byte	Access Type	Default Value	Description
0x0804	HVCON	1	RW	N/A	High Voltage Interface Control MMR. See the High Voltage Interface Control Register section and Table 70 and Table 71.
0x080C	HVDAT	1	RW	N/A	High Voltage Interface Data MMR. See the High Voltage Data Register section and Table 72.

Table 26. STI Base Address = 0xFFFF0880

Address	Name	Byte	Access Type	Default Value	Description
0x0880	STIKEY0	4	W	N/A	STICON Prewrite Key. See the Serial Test Interface Key0 Register section.
0x0884	STICON	2	RW	0x0000	Serial Test Interface Control MMR. See the Serial Test Interface Control Register section.
0x0888	STIKEY1	4	W	N/A	STICON Postwrite Key. See the Serial Test Interface Key1 Register section and Table 90.
0x088C	STIDAT0	2	RW	0x0000	STI Data MMR 0. See the Serial Test Interface Data0 Register section.
0x0890	STIDAT1	2	RW	0x0000	STI Data MMR 1. See the Serial Test Interface Data1 Register section.
0x0894	STIDAT2	2	RW	0x0000	STI Data MMR 2. See the Serial Test Interface Data2 Register section.

Table 27. SPI Base Address = 0xFFFF0A00

Address	Name	Byte	Access Type	Default Value	Description
0x0A00	SPISTA	1	R	0x00	SPI Status MMR. See the SPI Status Register section and Table 89.
0x0A04	SPIRX	1	R	0x00	SPI Receive MMR. See the SPI Receive Register section.
0x0A08	SPI TX	1	W		SPI Transmit MMR. See the SPI Transmit Register section.
0x0A0C	SPIDIV	1	RW	0x1B	SPI Baud Rate Select MMR. See the SPI Divider Register section.
0x0A10	SPICON	2	RW	0x00	SPI Control MMR. See the SPI Control Register section and Table 88.

Table 28. GPIO Base Address = 0xFFFF0D00

Address	Name	Byte	Access Type	Default Value	Description
0x0D00	GP0CON	4	RW	0x11100000	GPIO Port0 Control MMR. See the GPIO Port0 Control Register section and Table 58.
0x0D04	GP1CON	4	RW	0x10000000	GPIO Port1 Control MMR. See the GPIO Port1 Control Register section and Table 59.
0x0D08	GP2CON	4	RW	0x01000000	GPIO Port2 Control MMR. See the GPIO Port2 Control Register section and Table 60.
0x0D20	GP0DAT ¹	4	RW	0x000000XX	GPIO Port0 Data Control MMR. See the GPIO Port0 Data Register section and Table 61.
0x0D24	GP0SET	4	W		GPIO Port0 Data Set MMR. See the GPIO Port0 Set Register section and Table 64.
0x0D28	GP0CLR	4	W		GPIO Port0 Data Clear MMR. See the GPIO Port0 Clear Register section and Table 67.
0x0D30	GP1DAT ¹	4	RW	0x000000XX	GPIO Port1 Data Control MMR. See the GPIO Port1 Data Register section and Table 62.
0x0D34	GP1SET	4	W		GPIO Port1 Data Set MMR. See the GPIO Port1 Set Register section and Table 65.
0x0D38	GP1CLR	4	W		GPIO Port1 Data Clear MMR. See the GPIO Port1 Clear Register section and Table 68.
0x0D40	GP2DAT ¹	4	RW	0x000000XX	GPIO Port2 Data Control MMR. See the GPIO Port2 Data Register section and Table 63.
0x0D44	GP2SET	4	W		GPIO Port2 Data Set MMR. See the GPIO Port2 Set Register section and Table 66.
0x0D48	GP2CLR	4	W		GPIO Port2 Data Clear MMR. See the GPIO Port2 Clear Register section and Table 69.

¹ Depends on the level on the external GPIO pins.

Table 29. Flash/EE Base Address = 0xFFFF0E00

Address	Name	Byte	Access Type	Default Value	Description
0x0E00	FEE0STA	1	R	0x20	Flash/EE Status MMR.
0x0E04	FEE0MOD	1	RW	0x00	Flash/EE Control MMR.
0x0E08	FEE0CON	1	RW	0x07	Flash/EE Control MMR. See Table 13.
0x0E0C	FEE0DAT	2	RW	0x0000	Flash/EE Data MMR.
0x0E10	FEE0ADR	2	RW		Flash/EE Address MMR.
0x0E18	FEE0SIG	3	R	0xFFFFFFFF	Flash/EE LFSR MMR.
0x0E1C	FEE0PRO	4	RW	0x00000000	Flash/EE Protection MMR. See the Flash/EE Memory Protection Registers section and Table 16.
0x0E20	FEE0HID	4	RW	0xFFFFFFFF	Flash/EE Protection MMR. See the Flash/EE Memory Protection Registers and Table 16.

16-BIT, Σ - Δ ANALOG-TO-DIGITAL CONVERTERS

The ADuC7034 incorporates two independent sigma-delta (Σ - Δ) analog-to-digital converters (ADCs) namely, the current channel ADC (I-ADC) and the voltage/temperature channel ADC (V/T-ADC). These precision measurement channels integrate on-chip buffering, a programmable gain amplifier, 16-bit, Σ - Δ modulators, and digital filtering for precise measurement of current, voltage, and temperature variables in 12 V automotive battery systems.

Current Channel ADC (I-ADC)

The I-ADC converts battery current sensed through an external 100 $\mu\Omega$ shunt resistor. On-chip programmable gain means that the I-ADC can be configured to accommodate battery current levels from ± 1 A to ± 1500 A.

As shown in Figure 17, the I-ADC employs a Σ - Δ conversion technique to realize 16 bits of no missing codes performance.

The Σ - Δ modulator converts the sampled input signal into a digital pulse train whose duty cycle contains the digital information. A modified Sinc3, programmable, low-pass filter is then employed to decimate the modulator output data stream to give a valid 16-bit data conversion result at programmable output rates from 4 Hz to 8 kHz in normal mode, and 1 Hz to 2 kHz in low power mode.

The I-ADC also incorporates counter, comparator, and accumulator logic. This allows the I-ADC result to generate an interrupt after a predefined number of conversions have elapsed or if the I-ADC result exceeds a programmable threshold value. A fast ADC overrange feature is also supported. Once enabled, a 32-bit accumulator automatically sums the 16-bit I-ADC results.

The time to a first valid (fully settled) result on the current channel is three ADC conversion cycles with chop mode turned off and two ADC conversion cycles with chop mode turned on.

91019659

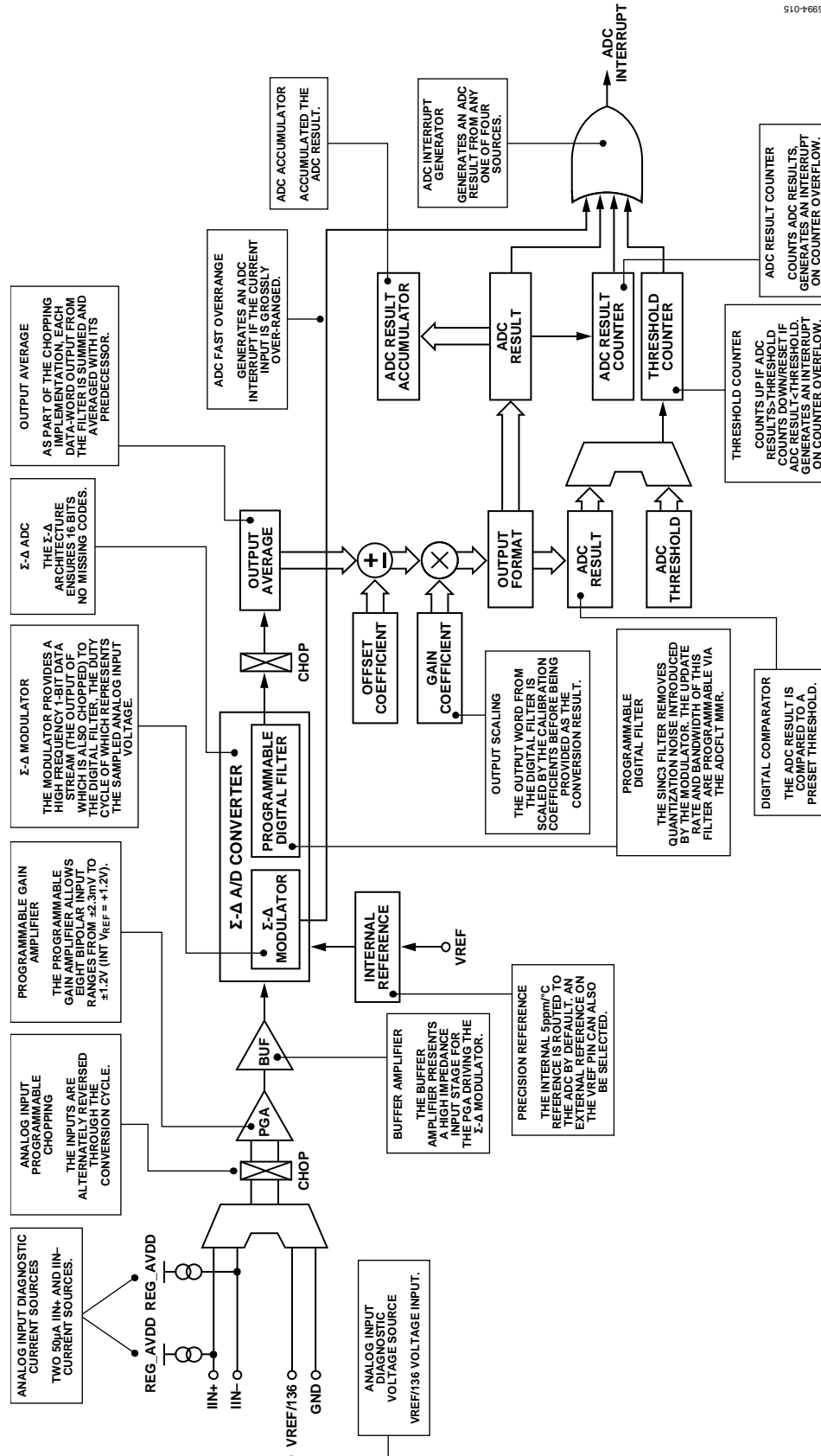

Figure 17. Current ADC, Top Level Overview

Voltage/Temperature Channel ADC (V/T-ADC)

The voltage/temperature channel ADC (V/T-ADC) converts additional battery parameters such as voltage and temperature. The input to this channel can be multiplexed from one of three input sources, namely: an external voltage, an external temperature sensor circuit, and an on-chip temperature sensor.

As with the current channel ADC described previously, the V/T-ADC employs an identical Σ - Δ conversion technique, including a modified Sinc3 low-pass filter to give a valid 16-bit data conversion result at programmable output rates from 4 Hz to 8 kHz. An external RC filter network is not required because this is internally implemented in the voltage channel.

The external battery voltage (VBAT) is routed to the ADC input via an on-chip, high voltage (divide-by-24), resistive attenuator. The voltage attenuator buffers are automatically enabled when the voltage attenuator input is selected.

The battery temperature can be derived through the on-chip temperature sensor or an external temperature sensor input. The time to a first valid (fully settled) result after an input channel switch on the voltage/temperature channel is three ADC conversion cycles with chop mode turned off.

This ADC is again buffered, but unlike the current channel, has a fixed input range of 0 V to V_{REF} on VTEMP and 0 V to 28.8 V on VBAT (assuming an internal 1.2 V reference). A top level overview of this ADC signal chain is shown in Figure 18.

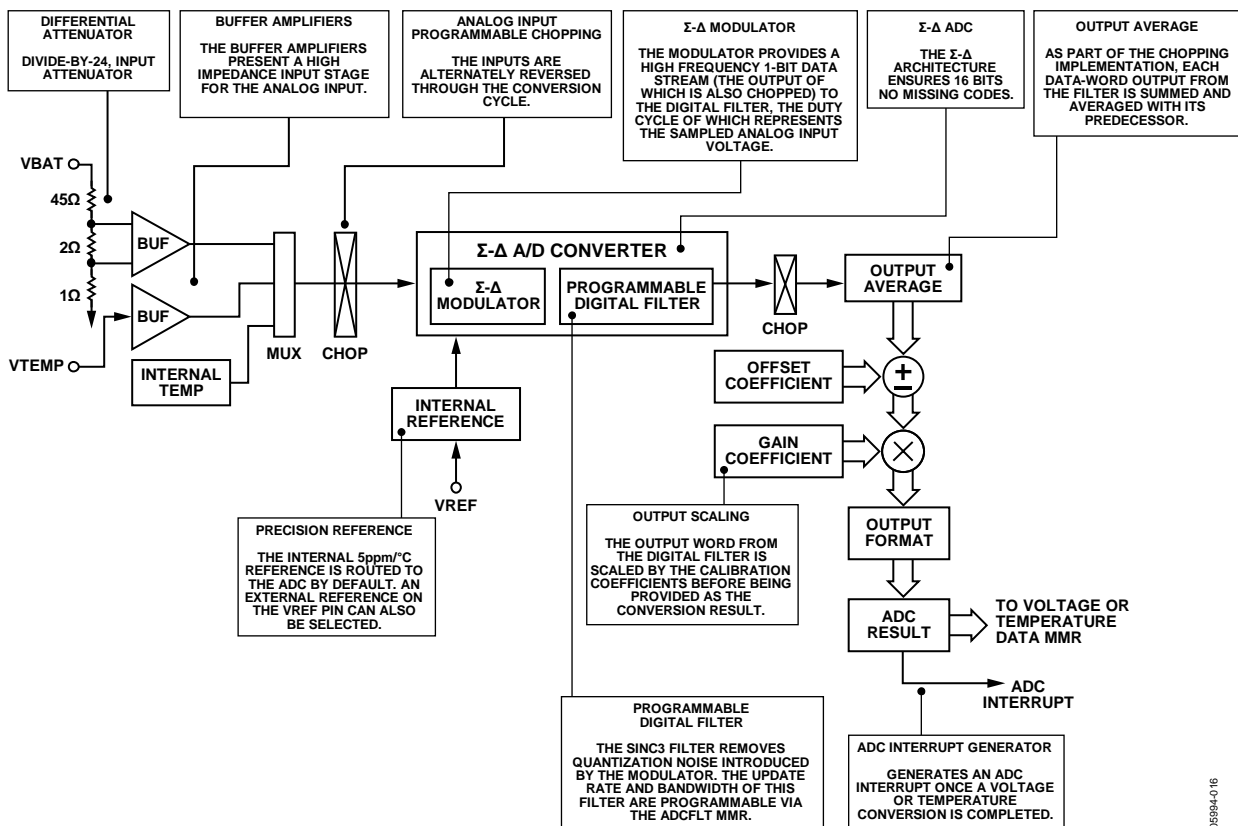

Figure 18. Voltage/Temperature ADC, Top Level Overview

05594-016

ADC GROUND SWITCH

The ADuC7034 features an integrated ground switch pin, GND_SW, Pin15. This switch allows the user to dynamically disconnect ground from external devices. It allows either a direct connection to ground, or a connection to ground using a 20 kΩ resistor. This additional resistor can be used to reduce the number of external components required for an NTC circuit. The ground switch feature can be used for reducing power consumption on application specific boards.

An example application is shown in Figure 19.

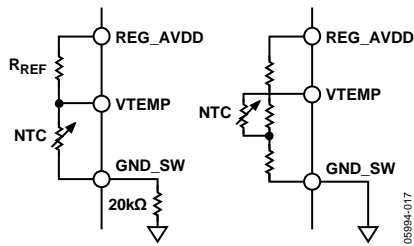

Figure 19. Example External Temperature Sensor Circuits

This diagram shows an external NTC used in two modes, one using the internal 20 kΩ resistor, and the second showing a direct connection to ground, via the GND_SW.

ADCCFG[7] controls the connection of the ground switch to ground and ADCMDE[6] controls the GND_SW resistance as shown in Figure 20.

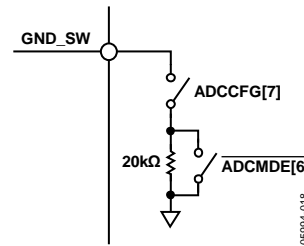

Figure 20. Internal Ground Switch Configuration

The possible combinations are shown in Table 30.

Table 30. GND_SW Configuration

ADCCFG[7]	ADCMDE[6]	GND_SW
0	0	Floating
0	1	Floating
1	0	Direct connection to ground
1	1	Connected to ground via 20 kΩ resistor

ADC NOISE PERFORMANCE TABLES

Table 31, Table 32, and Table 33 list the output rms noise in μV for some typical output update rates on the I- and V/T-ADCs. The numbers are typical and are generated at a differential input voltage of 0 V. The output rms noise is specified as the standard deviation (or 1 Sigma) of the distribution of ADC output codes collected when the ADC input voltage is at a dc voltage. It is expressed as $V \mu\text{rms}$.

Table 31. Current Channel ADC, Normal Power Mode, Typical Output RMS Noise

ADCFLT	Data Update Rate	ADC Input Range									
		$\pm 2.3 \text{ mV}$ (512)	$\pm 4.6 \text{ mV}$ (256)	$\pm 4.68 \text{ mV}$ (128)	$\pm 18.75 \text{ mV}$ (64)	$\pm 37.5 \text{ mV}$ (32)	$\pm 75 \text{ mV}$ (16)	$\pm 150 \text{ mV}$ (8)	$\pm 300 \text{ mV}$ (4 ¹)	$\pm 600 \text{ mV}$ (2 ¹)	$\pm 1.2 \text{ V}$ (1 ¹)
0xBF1D	4 Hz	0.040 μV	0.040 μV	0.043 μV	0.045 μV	0.087 μV	0.175 μV	0.35 μV	0.7 μV	1.4 μV	2.8 μV
0x961F	10 Hz	0.060 μV	0.060 μV	0.060 μV	0.065 μV	0.087 μV	0.175 μV	0.35 μV	0.7 μV	1.4 μV	2.8 μV
0x007F	50 Hz	0.142 μV	0.142 μV	0.144 μV	0.145 μV	0.170 μV	0.305 μV	0.380 μV	0.7 μV	2.3 μV	2.8 μV
0x0007	1 kHz	0.620 μV	0.620 μV	0.625 μV	0.625 μV	0.770 μV	1.310 μV	1.650 μV	2.520 μV	7.600 μV	7.600 μV
0x0000	8 kHz	2.000 μV	2.000 μV	2.000 μV	2.000 μV	2.650 μV	4.960 μV	8.020 μV	15.0 μV	55.0 μV	55.0 μV

¹ The maximum absolute input voltage allowed is -200 mV to $+300 \text{ mV}$ relative to ground.

Table 32. Voltage Channel ADC, Typical Output RMS Noise (Referred to ADC Voltage Attenuator Input)

ADCFLT	Data Update Rate	28.8 V ADC Input Range
0xBF1D	4 Hz	65 μV
0x961F	10 Hz	65 μV
0x0007	1 kHz	180 μV
0x0000	8 kHz	1600 μV

Table 33. Temperature Channel ADC, Typical Output RMS Noise

ADCFLT	Data Update Rate	0 V to 1.2 V ADC Input Range
0xBF1D	4 Hz	2.8 μV
0x961F	10 Hz	2.8 μV
0x0007	1 kHz	7.5 μV
0x0000	8 kHz	55 μV

ADC MMR INTERFACE

The ADC is controlled and configured through a number of MMRs that are described in detail in the following sections.

All bits defined in the top eight MSBs (Bits[8:15]) of the MMR are used as flags only and do not generate interrupts. All bits defined in the lower eight LSBs (Bits[0:7]) of this MMR are logic OR'ed to produce a single ADC interrupt to the MCU core. In response to an ADC interrupt, user code should interrogate the ADCSTA MMR to determine the source of the interrupt. Each ADC interrupt source can be individually masked via the ADCMSKI MMR described in ADC Interrupt Mask Register section.

ADC Status Register

Name: ADCSTA

Address: 0xFFFF0500

Default Value: 0x0000

Access: Read only

Function: This read only register holds general status information related to the mode of operation or current status of the ADuC7034 ADCs.

Table 34. ADCSTA MMR Bit Designations

Bit	Description
15	ADC Calibration Status. This bit is set automatically in hardware to indicate an ADC calibration cycle has been completed. This bit is cleared after ADCMDE is written to.
14	ADC Temperature Conversion Error. This bit is set automatically in hardware to indicate that a temperature conversion overrange or underrange has occurred. The conversion result is clamped to negative full scale (underrange error) or positive full scale (overrange error) in this case. This bit is cleared when a valid (in-range) temperature conversion result is written to the ADC2DAT register.
13	ADC Voltage Conversion Error. This bit is set automatically in hardware to indicate that a voltage conversion overrange or underrange has occurred. The conversion result is clamped to negative full scale (underrange error) or positive full scale (overrange error) in this case. This bit is cleared when a valid (in-range) voltage conversion result is written to the ADC1DAT register.
12	ADC Current Conversion Error. This bit is set automatically in hardware to indicate that a current conversion overrange or underrange has occurred. The conversion result is clamped to negative full scale (underrange error) or positive full scale (overrange error) in this case. This bit is cleared when a valid (in-range) current conversion result is written to the ADC0DAT register.
11 to 5	Not Used. These bits are reserved for future functionality and should not be monitored by user code.
4	Current Channel ADC Comparator Threshold. This bit is only valid if the current channel ADC comparator is enabled via the ADCCFG MMR. This bit is set by hardware if the absolute value of the I-ADC conversion result exceeds the value written in the ADC0TH MMR. If the ADC threshold counter is used (ADC0TCL), this bit is only set when the specified number of I-ADC conversions equals the value in the ADC0THV MMR.
3	Current Channel ADC Overage Bit. If the overrange detect function is enabled via the ADCCFG MMR, this bit is set by hardware if the I-ADC input is grossly (>30% approximate) overrange. This bit is updated every 125 μ s. After it is set, this bit can only be cleared by software when ADCCFG[2] is cleared to disable the function, or the ADC gain is changed via the ADC0CON MMR.

All ADC result ready bits are cleared by a read of the ADC0DAT MMR. If the Current Channel ADC is not enabled, all ADC result ready bits are cleared by a read of the ADC1DAT or ADC2DAT MMRs. To ensure that I-ADC and V/T-ADC conversion data are synchronous, user code should first read the ADC1DAT MMR and then ADC0DAT MMR. New ADC conversion results are not written to the ADCxDAT MMRs unless the respective ADC result ready bits are first cleared. The only exception to this rule is the data conversion result updates when the ARM core is powered down. In this mode, ADCxDAT registers always contain the most recent ADC conversion result even though the ready bits have not been cleared.

Bit	Description
2	Temperature Conversion Result Ready Bit. If the Temperature Channel ADC is enabled, this bit is set by hardware as soon as a valid temperature conversion result is written in the temperature data register (ADC2DAT MMR). It is also set at the end of a calibration. This bit is cleared by reading either ADC2DAT or ADC0DAT.
1	Voltage Conversion Result Ready Bit. If the voltage channel ADC is enabled, this bit is set by hardware as soon as a valid voltage conversion result is written in the voltage data register (ADC1DAT MMR). It is also set at the end of a calibration. This bit is cleared by reading either ADC1DAT or ADC0DAT.
0	Current Conversion Result Ready Bit. If the current channel ADC is enabled, this bit is set by hardware as soon as a valid current conversion result is written in the current data register (ADC0DAT MMR). It is also set at the end of a calibration. This bit is cleared by reading ADC0DAT.

ADC Interrupt Mask Register

Name: ADCMSKI

Address: 0xFFFF0504

Default Value: 0x00

Access: Read/write

Function: This register allows the ADC interrupt sources to be individually enabled. The bit positions in this register are the same as the lower eight bits in the ADCSTA MMR. If a bit is set by user code to a 1, the respective interrupt is enabled. By default, all bits are 0, meaning all ADC interrupt sources are disabled.

ADC Mode Register

Name: ADCMDE

Address: 0xFFFF0508

Default Value: 0x00

Access: Read/write

Function: The ADC Mode MMR is an 8-bit register that configures the mode of operation of the ADC subsystem.

Table 35. ADCMDE MMR Bit Designations

Bit	Description
7	Not Used. This bit is reserved for future functionality and should be written as 0 by user code.
6	20 k Ω Resistor Select. This bit is set to 1 to select the 20 k Ω resistor as shown in Figure 20. This bit is set to 0 to select the direct path to ground as shown in Figure 20 (default).
5	Low Power Mode Reference Select. This bit is set to 1 to enable the precision voltage reference in either low power mode or low power plus mode. This increases current consumption. This bit is set to 0 to enable the low power voltage reference in either low power mode or low power plus mode (default).
4 to 3	ADC Power Mode Configuration. 0, 0 = ADC normal mode. If enabled, the ADC operates with normal current consumption yielding optimum electrical performance. 0, 1 = ADC low power mode. If enabled, the I-ADC operates with reduced current consumption. This limitation in current consumption is achieved (at the expense of ADC noise performance) by fixing the gain to 128 and using the on-chip low power (131 kHz) oscillator to directly drive the ADC circuits.

Bit	Description
	<p>1, 0 = ADC low power plus mode. If enabled, the ADC operates with reduced current consumption. In this mode, the gain is fixed to 512 and the current consumed is approximately 200 μA more than the ADC low power mode. The additional current consumed also ensures that the ADC noise performance is better than that achieved in ADC low power mode.</p> <p>1, 1 = not defined.</p>
2 to 0	<p>ADC Operation Mode Configuration.</p> <p>0, 0, 0 = ADC power-down mode. All ADC circuits (including internal reference) are powered-down.</p> <p>0, 0, 1 = ADC continuous conversion mode. In this mode, any enabled ADC continuously converts.</p> <p>0, 1, 0 = ADC single conversion mode. In this mode, any enabled ADC performs a single conversion. The ADC enters idle mode when the single shot conversion is complete. A single conversion takes two to three ADC clock cycles depending on the chop mode.</p> <p>0, 1, 1 = ADC idle mode. In this mode, the ADC is fully powered on but is held in reset.</p> <p>1, 0, 0 = ADC self-offset calibration. In this mode, an offset calibration is performed on any enabled ADC using an internally generated 0 V. The calibration is carried out at the user programmed ADC settings; therefore, as with a normal single ADC conversion, it takes two to three ADC conversion cycles before a fully settled calibration result is ready. The calibration result is automatically written to the ADCxOF MMR of the respective ADC. The ADC returns to idle mode and the calibration and conversion ready status bits are set at the end of an offset calibration cycle.</p> <p>1, 0, 1 = ADC self-gain calibration. In this mode, a gain calibration against an internal reference voltage is performed on all enabled ADCs. A gain calibration is a two-stage process and takes twice the time of an offset calibration. The calibration result is automatically written to the ADCxGN MMR of the respective ADC. The ADC returns to idle mode and the calibration and conversion ready status bits are set at the end of a gain calibration cycle. An ADC self-gain calibration should only be carried out on the current channel ADC. Preprogrammed, factory calibration coefficients (downloaded automatically from internal Flash/EE) should be used for voltage temperature measurements. If an external NTC is used, an ADC self-calibration should be performed on the temperature channel.</p> <p>1, 1, 0 = ADC system zero-scale calibration. In this mode, a zero-scale calibration is performed on enabled ADC channels against an external zero-scale voltage driven at the ADC input pins. The calibration is carried out at the user programmed ADC settings; therefore, as with a normal, single ADC conversion, it takes three ADC conversion cycles before a fully settled calibration result is ready.</p> <p>1, 1, 1 = ADC system full-scale calibration. In this mode, a full-scale calibration is performed on enabled ADC channels against an external full-scale voltage driven at the ADC input pins.</p>

Current Channel ADC Control Register

Name: ADC0CON

Address: 0xFFFF050C

Default Value: 0x0000

Access: Read/write

Function: The current channel ADC control MMR is a 16-bit register that is used to configure the I-ADC.

Note: If the current ADC is reconfigured via ADC0CON, the voltage ADC and temperature ADC are also reset.

Table 36. ADC0CON MMR Bit Designations

Bit	Description
15	<p>Current Channel ADC Enable.</p> <p>This bit is set to 1 by user code to enable the I-ADC.</p> <p>Clearing this bit to 0 powers down the I-ADC and resets the respective ADC ready bit in the ADCSTA MMR to 0.</p>
14, 13	<p>IIN Current Source Enable.</p> <p>0, 0 = current sources off.</p> <p>0, 1 = enables 50 μA current source on IIN+.</p> <p>1, 0 = enables 50 μA current source on IIN-.</p> <p>1, 1 = enables 50 μA current source on both IIN- and IIN+.</p>
12 to 10	Not Used. These bits are reserved for future functionality and should be written as zero.
9	<p>Current Channel ADC Output Coding.</p> <p>This bit is set to 1 by user code to configure I-ADC output coding as unipolar.</p> <p>This bit is cleared to 0 by user code to configure I-ADC output coding as twos complement.</p>

Bit	Description
8	Not Used. This bit is reserved for future functionality and should be written as zero.
7, 6	Current Channel ADC Input Select. 0, 0 = IIN+, IIN-. 0, 1 = IIN-, IIN- = diagnostic, internal short configuration. 1, 0 = $V_{REF}/136, 0V$, diagnostic, test voltage for gain settings ≤ 128 . Note: If (REG_AVDD, AGND) divided-by-two reference is selected, REG_AVDD is used for V_{REF} in this mode. This leads to ADC0DAT scaled by two.
	1, 1 = not defined.
5, 4	Current Channel ADC Reference Select. 0, 0 = internal, 1.2V precision reference selected. In ADC low power mode, the voltage reference selection is controlled by ADCMDE[5]. 0, 1 = external reference inputs (VREF, GND_SW) selected. 1, 0 = external reference inputs divided-by-two (VREF, GND_SW)/2 selected, this allows an external reference up to REG_AVDD. 1, 1 = (REG_AVDD, AGND) divided-by-two selected.
3 to 0	Current Channel ADC Gain Select. Note, nominal I-ADC full-scale input voltage = $(V_{REF}/gain)$. 0, 0, 0, 0 = I-ADC gain of 1. 0, 0, 0, 1 = I-ADC gain of 2. 0, 0, 1, 0 = I-ADC gain of 4. 0, 0, 1, 1 = I-ADC gain of 8. 0, 1, 0, 0 = I-ADC gain of 16. 0, 1, 0, 1 = I-ADC gain of 32. 0, 1, 1, 0 = I-ADC gain of 64. 0, 1, 1, 1 = I-ADC gain of 128. 1, 0, 0, 0 = I-ADC gain of 256. 1, 0, 0, 1 = I-ADC gain of 512. 1, x, x, x = I-ADC gain is undefined.

Voltage/Temperature Channel ADC Control Register**Name:** ADC1CON**Address:** 0xFFFF0510**Default Value:** 0x0000**Access:** Read/write**Function:** The voltage/temperature channel ADC control MMR is a 16-bit register that is used to configure the V/T-ADC.**Note:** When selecting the VBAT attenuator input, the voltage attenuator buffers are automatically enabled.**Table 37. ADC1CON MMR Bit Designations**

Bit	Description
15	Voltage/Temperature Channel ADC Enable. This bit is set to 1 by user code to enable the V/T-ADC. Clearing this bit to 0, powers down the V/T-ADC.
14, 13	VTEMP Current Source Enable. 0, 0 = current sources off. 0, 1 = enables 50 μ A current source on VTEMP. 1, 0 = enables 50 μ A current source on GND_SW. 1, 1 = enables 50 μ A current source on both VTEMP and GND_SW.
12 to 10	Not Used. These bits are reserved for future functionality and should not be modified by user code.
9	Voltage/Temperature Channel ADC Output Coding. This bit is set to 1 by user code to configure V/T-ADC output coding as unipolar. This bit is cleared to 0 by user code to configure V/T-ADC output coding as twos complement.
8	Not Used. This bit is reserved for future functionality and should be written as 0 by user code.
7, 6	Voltage/Temperature Channel ADC Input Select. 0, 0 = VBAT/24, AGND. VBAT attenuator selected. The high voltage buffers are enabled automatically in this configuration. 0, 1 = VTEMP, GND_SW. External temperature input selected, conversion result written to ADC2DAT. 1, 0 = internal sensor. Internal temperature sensor input selected, conversion result written to ADC2DAT. The temperature gradient is 0.33 mV/ $^{\circ}$ C; this is only applicable to the internal temperature sensor. 1, 1 = internal short. Shorted input.
5, 4	Voltage/Temperature Channel ADC Reference Select. 0, 0 = internal, 1.2 V precision reference selected. 0, 1 = external reference inputs (VREF, GND_SW) selected. 1, 0 = external reference inputs divided-by-two (VREF, GND_SW)/2 selected. This allows an external reference up to REG_AVDD. 1, 1 = (REG_AVDD, AGND)/2 selected for the voltage channel. (REG_AVDD, GND_SW)/2 selected for the temperature channel.
3 to 0	Not Used. These bits are reserved for future functionality and should not be written as 0 by user code.

ADC Filter Register

Name: ADCFLT

Address: 0xFFFF0518

Default Value: 0x0007

Access: Read/write

Function: The ADC Filter MMR is a 16-bit register that controls the speed and resolution of the on-chip ADCs.

Note: If ADCFLT is modified, the current and voltage/temperature ADCs are reset.

Table 38. ADCFLT MMR Bit Designations

Bit	Description
15	Chop Enable. Set by the user to enable system chopping of all active ADCs. When this bit is set, the ADC has very low offset errors and drift, but the ADC output rate is reduced by a factor of three if AF = 0 (see Sinc3 decimation factor, Bits[6:0] in this table). If AF > 0, then the ADC output update rate is the same with chop on or off. When chop is enabled, the settling time is two output periods.
14	Running Average. Set by the user to enable a running-average-by-two function reducing ADC noise. This function is automatically enabled when chopping is active. It is an optional feature when chopping is inactive, and if enabled (when chopping is inactive) does not reduce the ADC output rate but does increase the settling time by one conversion period. Cleared by the user to disable the running average function.
13 to 8	Averaging Factor (AF). The values written to these bits are used to implement a programmable first-order Sinc3 postfilter. The averaging factor can further reduce ADC noise at the expense of output rate as described in Bits[6:0] Sinc3 decimation factor in this table.
7	Sinc3 Modify. Set by the user to modify the standard Sinc3 frequency response to increase the filter stop band rejection by approximately 5 dB. This is achieved by inserting a second notch (NOTCH2) at $f_{NOTCH2} = 1.333 \times f_{NOTCH}$ where f_{NOTCH} is the location of the first notch in the response.
6 to 0	Sinc3 Decimation Factor (SF) ¹ . The value (SF) written in these bits controls the oversampling (decimation factor) of the Sinc3 filter. The output rate from the Sinc3 filter is given by $f_{ADC} = (512,000 / ((SF + 1) \times 64)) \text{ Hz}^2$ when the chop bit (Bit 15, chop enable) = 0 and the averaging factor (AF) = 0. This is valid for all SF values ≤ 125. For SF = 126, f_{ADC} is forced to 60 Hz. For SF = 127, f_{ADC} is forced to 50 Hz. For information on calculating the f_{ADC} for SF (other than 126 and 127) and AF values, refer to Table 39.

¹ Due to limitations on the digital filter internal data path, there are some limitations on the combinations of the Sinc3 decimation factor (SF) and averaging factor (AF) that can be used to generate a required ADC output rate. This restriction limits the minimum ADC update in normal power mode to 4 Hz or 1 Hz in lower power mode.

² In low power mode and low power plus mode, the ADC is driven directly by the low power oscillator (131 kHz) and not 512 kHz. All f_{ADC} calculations should be divided by 4 (approx).

Table 39. ADC Conversion Rates and Settling Times

Chop Enabled	Averaging Factor	Running Average	f_{ADC}	$t_{SETTLING}^1$
No	No	No	$\frac{512,000}{[SF + 1] \times 64}$	$\frac{3}{f_{ADC}}$
No	No	Yes	$\frac{512,000}{[SF + 1] \times 64}$	$\frac{4}{f_{ADC}}$
No	Yes	No	$\frac{512,000}{[SF + 1] \times 64 \times [3 + AF]}$	$\frac{1}{f_{ADC}}$
No	Yes	Yes	$\frac{512,000}{[SF + 1] \times 64 \times [3 + AF]}$	$\frac{2}{f_{ADC}}$
Yes	N/A	N/A	$\frac{512,000}{[SF + 1] \times 64 \times [3 + AF] + 3}$	$\frac{2}{f_{ADC}}$

¹ An additional time of approximately 60 μ s per ADC is required before the first ADC is available.

Table 40. Allowable Combinations of SF and AF

SF	AF Range		
	0	1 to 7	8 to 63
0 to 31	Yes	Yes	Yes
32 to 63	Yes	Yes	No
64 to 127	Yes	No	No

ADC Configuration Register

Name: ADCCFG

Address: 0xFFFF051C

Default Value: 0x00

Access: Read/write

Function: The 8-bit ADC Configuration MMR controls extended functionality related to the on-chip ADCs.

Table 41. ADCCFG MMR Bit Designations

Bit	Description
7	Analog Ground Switch Enable. This bit is set to 1 by user software to connect the external GND_SW pin (Pin 15) to an internal analog ground reference point. This bit can be used to connect and disconnect external circuits and components to ground under program control and thereby minimize dc current consumption when the external circuit or component is not being used. This bit is used in conjunction with ADCMDE[6] to select a 20 kΩ resistor to ground.
6, 5	Current Channel (32-Bit) Accumulator Enable. 0, 0 = accumulator disabled and reset to 0. The accumulator must be disabled for a full ADC conversion, (ADCSTA[0] set twice) before the accumulator can be re-enabled to ensure the accumulator is reset. 0, 1 = accumulator active. Positive current values are added to the accumulator total; the accumulator can overflow if allowed to run for >65,535 conversions. Negative current values are subtracted from the accumulator total; the accumulator is clamped to a minimum value of 0. 1, 0 = accumulator active. Positive current values are added to the accumulator total; the accumulator can overflow if allowed to run for >65,535 conversions. The absolute values of negative current are subtracted from the accumulator total; the accumulator in this mode continues to accumulate negatively, below 0. 1, 1 = not defined.
4, 3	Current Channel ADC Comparator Enable. 0, 0 = comparator disabled. 0, 1 = comparator active, interrupt asserted if absolute value of I-ADC conversion result $ \geq A+DC0TH$. 1, 0 = comparator count mode active, interrupt asserted if absolute value of an I-ADC conversion result $ \geq ADC0TH$ for the number of ADC0TCL conversions. A conversion value $ < ADC0TH$ resets the threshold counter value (ADC0THV) to 0. 1, 1 = comparator count mode active, interrupt asserted if absolute value of an I-ADC conversion result $ \geq ADC0TH$ for the number of ADC0TCL conversions. A conversion value $ < ADC0TH$ decrements the threshold counter value (ADC0THV) towards 0.
2	Current Channel ADC Overrange Enable. Set by user to enable a coarse comparator on the Current Channel ADC. If the current reading is grossly (>30% approx.) overrange for the active gain setting, then the overrange bit in the ADCSTA MMR is set. The current must be outside this range for greater than 125 μs for the flag to be set. This feature should not be used in ADC low power mode.
1	Not Used. This bit is reserved for future functionality and should be written as 0 by user code.
0	Current Channel ADC, Result Counter Enable. Set by user to enable the result count mode. In this mode an I-ADC interrupt is generated only when ADC0RCV = ADC0RCL. This allows the I-ADC to continuously monitor current but only interrupt the MCU core after a defined number of conversions. The voltage/temperature ADC also continues to convert if enabled, but again, only the last conversion result is available (intermediate V/T-ADC conversion results are not stored) when the ADC counter interrupt occurs.

Current Channel ADC Data Register

Name: ADC0DAT

Address: 0xFFFF0520

Default Value: 0x0000

Access: Read only

Function: This ADC Data MMR holds the 16-bit conversion result from the I-ADC. The ADC does not update this MMR if the ADC0 conversion result ready bit (ADCSTA[0]) is set. A read of this MMR by the MCU clears all asserted ready flags (ADCSTA[2:0]).

Voltage Channel ADC Data Register

Name: ADC1DAT

Address: 0xFFFF0524

Default Value: 0x0000

Access: Read only

Function: This ADC Data MMR holds the 16-bit voltage conversion result from the V/T-ADC. The ADC does not update this MMR if the voltage conversion result ready bit (ADCSTA[1]) is set. If I-ADC is not active, a read of this MMR by the MCU clears all asserted ready flags (ADCSTA[2:1]).

Temperature Channel ADC Data Register

Name: ADC2DAT

Address: 0xFFFF0528

Default Value: 0x0000

Access: Read only

Function: This ADC Data MMR holds the 16-bit temperature conversion result from the V/T-ADC. The ADC does not update this MMR if the temperature conversion result ready bit (ADCSTA[2]) is set. If I-ADC and V-ADC is not active, a read of this MMR by the MCU clears all asserted ready flags (ADCSTA[2]). A read of this MMR clears ADCSTA[2].

Current Channel ADC Offset Calibration Register

Name: ADC0OF

Address: 0xFFFF0530

Default Value: Part specific, factory programmed

Access: Read/write access

Function: This ADC Offset MMR holds a 16-bit offset calibration coefficient for the I-ADC. The register is configured at power-on with a factory default value. However, this register automatically overwrites if an offset calibration of the I-ADC is initiated by the user via bits in the ADCMDE MMR. User code can only write to this calibration register if the ADC is in idle mode. An ADC must be enabled and in idle mode before being written to any offset or gain register. The ADC must be in idle mode for at least 23 μ s.

Voltage Channel ADC Offset Calibration Register**Name:** ADC1OF**Address:** 0xFFFF0534**Default Value:** Part specific, factory programmed**Access:** Read/write access

Function: This offset MMR holds a 16-bit offset calibration coefficient for the voltage channel. The register is configured at power-on with a factory default value. However, this register is automatically overwritten if an offset calibration of the voltage channel is initiated by the user via bits in the ADCMDE MMR. User code can only write to this calibration register if the ADC is in idle mode. An ADC must be enabled and in idle mode before being written to any offset or gain register. The ADC must be in idle mode for at least 23 μ s.

Temperature Channel ADC Offset Calibration Register**Name:** ADC2OF**Address:** 0xFFFF0538**Default Value:** Part specific, factory programmed**Access:** Read/write

Function: This ADC Offset MMR holds a 16-bit offset calibration coefficient for the temperature channel. The register is configured at power-on with a factory default value. However, this register is automatically overwritten if an offset calibration of the temperature channel is initiated by the user via bits in the ADCMDE MMR. User code can only write to this calibration register if the ADC is in idle mode. An ADC must be enabled and in idle mode before being written to any offset or gain register. The ADC must be in idle mode for at least 23 μ s.

Current Channel ADC Gain Calibration Register**Name:** ADC0GN**Address:** 0xFFFF053C**Default Value:** Part specific, factory programmed**Access:** Read/write

Function: This gain MMR holds a 16-bit gain calibration coefficient for scaling the I-ADC conversion result. The register is configured at power-on with a factory default value. However, this register is automatically overwritten if a gain calibration of the I-ADC is initiated by the user via bits in the ADCMDE MMR. User code can only write to this calibration register if the ADC is in idle mode. An ADC must be enabled and in idle mode before being written to any offset or gain register. The ADC must be in idle mode for at least 23 μ s.

Voltage Channel Gain Calibration Register**Name:** ADC1GN**Address:** 0xFFFF0540**Default Value:** Part specific, factory programmed**Access:** Read/write

Function: This gain MMR holds a 16-bit gain calibration coefficient for scaling a voltage channel conversion result. The register is configured at power-on with a factory default value. However, this register is automatically overwritten if a gain calibration of the voltage channel is initiated by the user via bits in the ADCMDE MMR. User code can only write to this calibration register if the ADC is in idle mode. An ADC must be enabled and in idle mode before being written to any offset or gain register. The ADC must be in idle mode for at least 23 μ s.

Temperature Channel Gain Calibration Register**Name:** ADC2GN**Address:** 0xFFFF0544**Default Value:** Part specific, factory programmed**Access:** Read/write

Function: This gain MMR holds a 16-bit gain calibration coefficient for scaling a temperature channel conversion result. The register is configured at power-on with a factory default value. However, this register is automatically overwritten if a gain calibration of the temperature channel is initiated by the user via bits in the ADCMDE MMR. User code can only write to this calibration register if the ADC is in idle mode. An ADC must be enabled and in idle mode before being written to any offset or gain register. The ADC must be in idle mode for at least 23 μ s.

Current Channel ADC Result Counter Limit Register**Name:** ADC0RCL**Address:** 0xFFFF0548**Default Value:** 0x0001**Access:** Read/write

Function: This 16-bit MMR sets the number of conversions required before an ADC interrupt is generated. By default this register is set to 0x01. The ADC counter function must be enabled via the ADC result counter enable bit in the ADCCFG MMR.

Current Channel ADC Result Count Register**Name:** ADC0RCV**Address:** 0xFFFF054C**Default Value:** 0x0000**Access:** Read only

Function: This 16-bit, read only MMR holds the current number of I-ADC conversion results. It is used in conjunction with ADC0RCL to mask I-ADC interrupts, generating a lower interrupt rate. When ADC0RCV = ADC0RCL, the value in ADC0RCV resets to 0 and recommences counting. It can also be used in conjunction with the accumulator (ADC0ACC) to allow an average current calculation to be undertaken. The result counter is enabled via ADCCFG[0]. This MMR is also reset to 0 when the I-ADC is reconfigured, that is, when the ADC0CON or ADCMDE are written.

Current Channel ADC Threshold Register

Name:	ADC0TH
Address:	0xFFFF0550
Default Value:	0x0000
Access:	Read/write
Function:	This 16-bit MMR sets the threshold against which the absolute value of the I-ADC conversion result is compared. In unipolar mode ADC0TH[15:0] are compared, and in twos complement mode, ADC0TH[14:0] are compared.

Current Channel ADC Threshold Count Limit Register

Name:	ADC0TCL
Address:	0xFFFF0554
Default Value:	0x01
Access:	Read/write
Function:	This 8-bit MMR determines how many cumulative (values below the threshold decrement or reset the count to 0) I-ADC conversion result readings above ADC0TH must occur before the I-ADC comparator threshold bit is set in the ADCSTA MMR generating an ADC interrupt. The I-ADC comparator threshold bit is asserted as soon as the ADC0THV = ADC0TCL.

Current Channel ADC Threshold Count Register

Name:	ADC0THV
Address:	0xFFFF0558
Default Value:	0x00
Access:	Read only
Function:	This 8-bit MMR is incremented every time the absolute value of an I-ADC conversion result $ I \geq \text{ADC0TH}$. This register is decremented or reset to 0 every time the absolute value of an I-ADC conversion result $ I < \text{ADC0TH}$. The configuration of this function is enabled via the current channel ADC comparator bits in the ADCCFG MMR.

Current Channel ADC Accumulator Register

Name:	ADC0ACC
Address:	0xFFFF055C
Default Value:	0x00000000
Access:	Read only
Function:	This 32-bit MMR holds the current accumulator value. The I-ADC ready bit in the ADCSTA MMR should be used to determine when it is safe to read this MMR. The MMR value is reset to 0 by disabling the accumulator in the ADCCFG MMR or reconfiguring the current channel ADC.

Low Power Voltage Reference Scaling Factor**Name:** ADCREF¹**Address:** 0xFFFF057C**Default Value:** Part specific, factory programmed**Access:** Read/write. Care should be taken not to write to this register.**Function:** This allows user code to correct for the initial error of the LPM reference^{2,3}. 0x8000 corresponds to no error when compared to the normal mode reference. The magnitude of the ADC result should be multiplied by the value in ADCREF and divided by 0x8000 to compensate for the actual value of the low power reference.¹ This register should not be used if the precision reference is being used in low power mode (if ADCMDE[5] is set).² If the LPM voltage reference is 1% below 1.200 V, then the value of ADCREF is approximately 0x7EB9. If the LPM voltage reference is 1% above 1.200 V, then the value of ADCREF is approximately 0x8147.³ This register corrects the effective value of the LPM reference at the temperature the reference is measured at during Analog Devices, Inc. production flow, which is 25°C. There is no change to the temperature coefficient of the LPM reference when using the ADCREF MMR.**ADC POWER MODES OF OPERATION**

The ADCs can be configured into various reduced or full power modes of operation by configuring ADCMDE[4:3] as appropriate. The ARM7 MCU can also be configured in low power modes of operation (POWCON[5:3]). The core power modes are independently controlled and are not related to the ADC power modes described in this section. Descriptions of the ADC power modes of operation follow.

ADC Startup Procedure

Prior to beginning a conversion, implement the following procedure:

1. Configure the current ADC (ADC0) into low power mode (ADC0CON = 0x8007; ADCMDE = 0x09).
2. Delay for 200 μ s.
3. Switch the current ADC (ADC0), into idle mode (ADCMDE = 0x03), keeping ADC0CON unchanged. If the voltage or temperature channels are to be used, enable them at this time.
4. Delay for 1 ms.
5. Switch ADCMDE to desired mode, for example, ADCMDE = 0x1.

ADC Normal Power Mode

In normal mode, the current and voltage/temperature channels are fully enabled. The ADC modulator clock is 512 kHz and enables the ADCs to provide regular conversion results at a rate of between 4 Hz and 8 kHz (see the ADC Filter Register section). Both channels are under full control of the MCU and can be reconfigured at any time. The default ADC update rate for all channels in this mode is 1.0 kHz.

It is worth emphasizing that I-ADC and V/T-ADC channels can be configured to initiate periodic, normal power mode, high accuracy, single conversion cycles before returning to ADC full power-down mode. This flexibility is facilitated under full MCU control via the ADCMDE MMR; it ensures that continuous periodic monitoring of battery current, voltage, and temperature settings is feasible while ensuring the average dc current consumption is minimized.

In ADC normal mode, the PLL must not be powered down.

ADC Low Power Mode

In ADC low power mode, the I-ADC is enabled in a reduced power and reduced accuracy configuration. The ADC modulator clock is now driven directly from the on-chip 131 kHz low power oscillator, which allows the ADC to be configured at update rates as low as 1 Hz (ADCFLT). The gain of the ADC in this mode is fixed at 128.

All of the ADC peripheral functions (result counter, digital comparator and accumulator) described earlier in normal power mode can still be enabled in low power mode.

Typically, in low power mode, the I-ADC only, is configured to run at a low update rate, continuously monitoring battery current. The MCU is in power-down mode and wakes up when the I-ADC interrupts the MCU. This happens after the I-ADC detects a current conversion beyond a preprogrammed threshold, setpoint, or a set number of conversions.

It is also possible to select either the ADC Precision Voltage Reference or the ADC Low Power Mode Voltage Reference via ADCMDE[5].

ADC Low Power Plus Mode

In low power plus mode, the I-ADC channel is enabled in a mode almost identical to low power mode (ADCMDE[4:3]). However, in this mode, the I-ADC gain is fixed at 512 and the ADC consumes an additional 200 μ A (approximately) to yield improved noise performance relative to the low power mode setting.

Again, all of the ADC peripheral functions (result counter, digital comparator, and accumulator) described in the ADC Startup Procedure

Prior to beginning a conversion, implement the following procedure:

- Configure the current ADC (ADC0) into low power mode (ADC0CON = 0x8007; ADCMDE = 0x09).
- Delay for 200 μ s.
- Switch the current ADC (ADC0), into idle mode (ADCMDE = 0x03), keeping ADC0CON unchanged. If the voltage or temperature channels are to be used, enable them at this time.
- Delay for 1 ms.
- Switch ADCMDE to desired mode, for example, ADCMDE = 0x1.

ADC Normal Power Mode section can still be enabled in low power plus mode.

As in low power mode, the I-ADC only is configured to run at a low update rate, continuously monitoring battery current. The MCU is in power-down mode and only wakes up when the I-ADC interrupts the MCU. This happens after the I-ADC detects a current conversion result beyond a preprogrammed threshold or setpoint.

It is also possible to select either the ADC Precision Voltage Reference or the ADC Low Power Mode Voltage Reference via ADCMDE[5].

ADC Comparator and Accumulator

Every I-ADC result can also be compared to a preset threshold level (ADC0TH) as configured via ADCCFG[4:3]. An MCU interrupt is generated if the absolute (sign independent) value of the ADC result is greater than the preprogrammed comparator threshold level. An extended function of this comparator function allows user code to configure a threshold counter (ADC0THV) to monitor the number of I-ADC results that have occurred above or below the preset threshold level. Again, an ADC interrupt is generated when the threshold counter reaches a preset value (ADC0TCL).

Finally, a 32-bit accumulator (ADC0ACC) function can be configured (ADCCFG[6:5]) allowing the I-ADC to add (or subtract) multiple I-ADC sample results. User code can read the

accumulated value directly (ADC0ACC) without any further software processing.

ADC Sinc3 Digital Filter Response

The overall frequency response on all ADuC7034 ADCs is dominated by the low-pass filter response of the on-chip Sinc3 digital filters. The Sinc3 filters are used to decimate the ADC Σ - Δ modulator output data bit stream to generate a valid 16-bit data result. The digital filter response is identical for all ADCs and is configured via the 16-bit ADC filter (ADCFLT) register. This register determines the overall throughput rate of the ADCs. The noise resolution of the ADCs is determined by the programmed ADC throughput rate. In the case of the current channel ADC, the noise resolution is determined by throughput rate and selected gain.

The overall frequency response and the ADC throughput is dominated by the configuration of the Sinc3 filter decimation factor (SF) bits (ADCFLT[6:0]) and the averaging factor (AF) bits (ADCFLT[13:8]). Due to limitations on the digital filter internal data path, there are some limitations on the allowable combinations of SF and AF that can be used to generate a required ADC output rate. This restriction limits the minimum ADC update in normal power mode to 4 Hz or 1 Hz in low power mode. The calculation of the ADC throughput rate is detailed in the ADCFLT bit designations table and the restrictions on allowable combinations of AF and SF values are outlined in Table 40.

By default, the ADCFLT = 0x07 configures the ADCs for a throughput of 1.0 kHz with all other filtering options (chop, running average, averaging factor, and Sinc3 modify) disabled. A typical filter response based on this default configuration is shown in Figure 21.

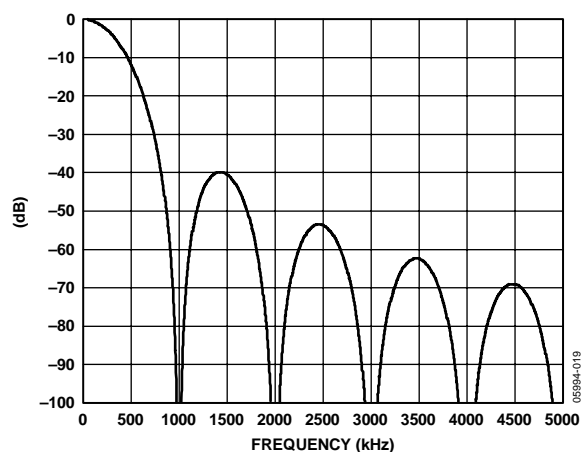

Figure 21. Typical Digital Filter Response at $f_{ADC} = 1.0$ kHz (ADCFLT = 0x0007)

An additional Sinc3 modify bit (ADCFLT[7]) is also available in the ADCFLT register. This bit is set by user code to modify the standard Sinc3 frequency response increasing the filter stop-

band rejection by approximately 5 dB. This is achieved by inserting a second notch (NOTCH2) at

$$f_{NOTCH2} = 1.333 \times f_{NOTCH}$$

where f_{NOTCH} is the location of the first notch in the response.

There is a slight increase in ADC noise if this bit is active. Figure 22 shows the modified 1 kHz filter response when the Sinc3 modify bit is active. The new notch is clearly visible at 1.33 kHz, as is the improvement in stop band rejection when compared to the standard 1 kHz response.

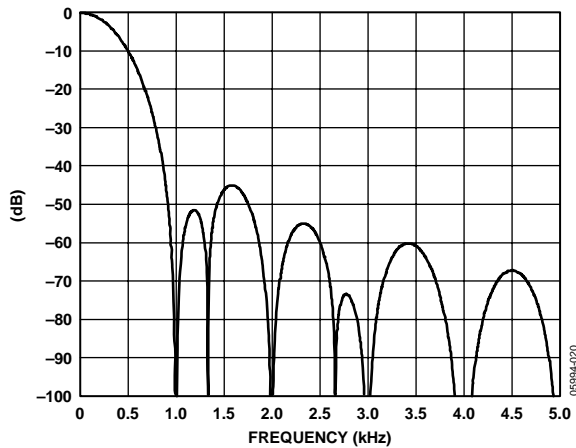

Figure 22. Modified Sinc3 Digital Filter Response at $f_{ADC} = 1.0$ kHz (ADCFLT = 0x0087)

In ADC normal power mode, the maximum ADC throughput rate is 8 kHz. This is configured by setting the SF and AF bits in the ADCFLT MMR to 0, with all other filtering options disabled. This results in 0x0000 written to ADCFLT. A typical 8 kHz filter response based on these settings is shown in Figure 23.

Figure 23. Typical Digital Filter Response at $f_{ADC} = 8$ kHz, (ADCFLT = 0x0000)

A modified version of the 8 kHz filter response can be configured by setting the running average bit (ADCFLT[14]). This has the effect of introducing an additional running-average-by-two filter on all ADC output samples. This further reduces

the ADC output noise and by maintaining an 8 kHz ADC throughput rate, the ADC settling time is increased by one full conversion period. The modified frequency response for this configuration is shown in Figure 24.

Figure 24. Typical Digital Filter Response at $f_{ADC} = 8$ kHz, (ADCFLT = 0x4000)

At very low throughput rates, the chop bit in the ADCFLT register can be enabled to minimize offset errors and, more importantly, temperature drift in the ADC offset error. With chop enabled, there are two primary variables (Sinc3 decimation factor and averaging factor) available to allow the user to select an optimum filter response, trading off filter bandwidth against ADC noise.

For example, with the Chop Bit ADCFLT[15] set to 1, increasing the SF value (ADCFLT[6:0]) to 0x1F (31 decimal) and selecting an AF value (ADCFLT[13:8]) of 0x16 (22 decimal) results in an ADC throughput of 10 Hz. The frequency response in this case is shown in Figure 25.

Figure 25. Typical Digital Filter Response at $f_{ADC} = 10$ Hz, (ADCFLT = 0x961F)

Changing SF to 0x1D and setting AF to 0x3F with the chop bit enabled, configures the ADC into its minimum throughput rate in normal mode of 4 Hz. The digital filter frequency response with this configuration is shown in Figure 26.

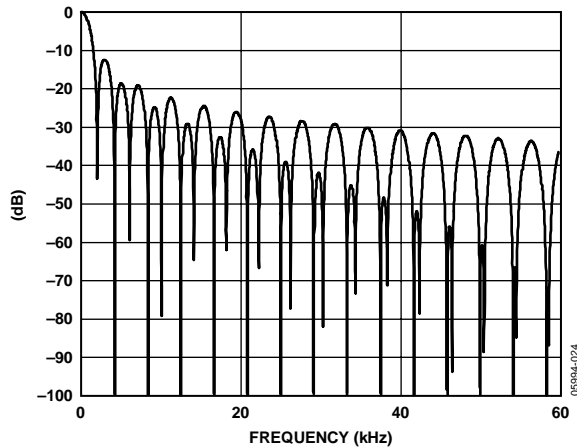

Figure 26. Typical Digital Filter Response at $f_{ADC} = 4$ Hz, (ADCFLT = 0xBF1D)

In ADC low power mode, the ADC, Σ - Δ modulator clock is no longer driven at 512 kHz, but is driven directly from the on-chip low power (131 kHz) oscillator. Subsequently, for the same ADCFLT configurations in normal mode, all filter values should be scaled by a factor of approximately four. This means that it is possible to configure the ADC for 1 Hz throughput in low power mode. The filter frequency response for this configuration is shown in Figure 27.

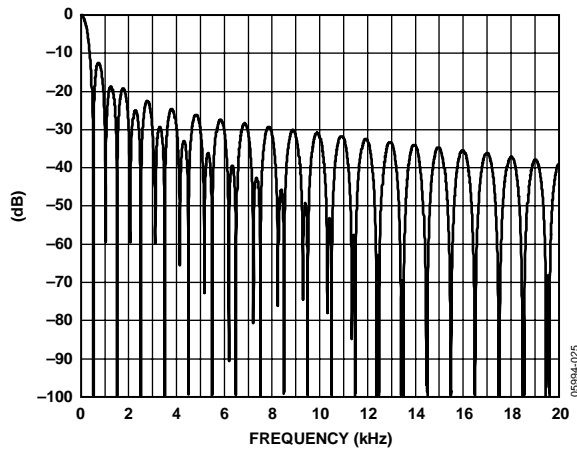

Figure 27. Typical Digital Filter Response at $f_{ADC} = 1$ Hz, (ADCFLT = 0xBD1F)

In general, it is possible to program different values of SF and AF in the ADCFLT register and achieve the same ADC update

Table 42. Common ADCFLT Configurations

ADC Mode	SF	AF	Other Config	ADCFLT	f_{ADC}	t_{SETTLE}
Normal	0x1D	0x3F	Chop On	0xBF1D	4 Hz	0.5 sec
Normal	0x1F	0x16	Chop On	0x961F	10 Hz	0.2 sec
Normal	0x07	0x00	None	0x0007	1 kHz	3 ms
Normal	0x07	0x00	Sinc3 Modify	0x0087	1 kHz	3 ms
Normal	0x03	0x00	Running Average	0x4003	2 kHz	2 ms
Normal	0x00	0x00	Running Average	0x4000	8 kHz	0.5 ms
Low Power	0x10	0x03	Chop On	0x8310	20 Hz	100 ms
Low Power	0x10	0x09	Chop On	0x8910	10 Hz	200 ms
Low Power	0x1F	0x3D	Chop On	0xBD1F	1 Hz	2 sec

rate. In practical terms, the trade off with any value of ADCFLT is frequency response vs. ADC noise. For optimum filter response and ADC noise when using combinations of SF and AF, best practice suggests choosing an SF in the range of 16 decimal to 40 decimal, or 0x10 to 0x28, and then increasing the AF value to achieve the required ADC throughput. Table 42 shows some common ADCFLT configurations.

ADC Calibration

As shown in detail in the top level diagrams (Figure 17 and Figure 18), the signal flow through all ADC channels can be described in simple steps.

1. An input voltage is applied through an input buffer (and PGA in the case of the I-ADC) to the Σ - Δ modulator.
2. The modulator output is applied to a programmable digital decimation filter.
3. The filter output result is then averaged if chopping is used.
4. An offset value (ADCxOF) is subtracted from the result.
5. This result is scaled by a gain value (ADCxGN).
6. Finally, the result is formatted as twos complement/offset binary, rounded to 16 bits, or clamped to \pm full scale.

Each ADC has a specific offset and gain correction or calibration coefficient associated with it that are stored in MMR-based offset and gain registers (ADCxOF and ADCxGN). The offset and gain registers can be used to remove offsets and gain errors arising within the part as well as system level offset and gain errors external to the part.

These registers are configured at power-on with a factory programmed calibration value. These factory calibration values vary from part to part reflecting the manufacturing variability of internal ADC circuits. However, these registers can also be overwritten by user code (only if the ADC is in idle mode) and are automatically overwritten if an offset or gain calibration cycle is initiated by the user through the mode bits in the ADCMDE[2:0] MMR. Two types of automatic calibration are available to the user, namely, self-calibration or system calibration.

Self-Calibration

In self (offset or gain) calibration, the ADC generates its calibration coefficient based on an internally generated 0 V in the case of self-offset calibration, and full-scale voltage in the case of self-gain calibration. It should be emphasized that ADC self-calibrations correct for offset and gain errors within the ADC. Self-calibrations cannot compensate for other external errors in the system, for example, shunt resistor tolerance/drift, external offset voltages, and so on.

Note that in self-calibration mode, ADC0GN must first contain the values for $PGA = 1$, before a calibration scheme is started.

System Calibration

In system (offset or gain) calibration, the ADC generates its calibration coefficient based on an externally generated zero-scale voltage (in the case of system offset calibration) and full-scale voltage (in the case of system gain calibration), which are applied to the external ADC input for the duration of the calibration cycle.

The duration of an offset calibration is a single conversion cycle ($3/f_{ADC}$ chop off, $2/f_{ADC}$ chop on) before returning the ADC to idle mode. A gain calibration is a two-stage process and, therefore, takes twice as long as an offset calibration cycle. When a calibration cycle is initiated, any ongoing ADC conversion is immediately halted, the calibration is automatically carried out at an ADC update rate programmed into ADCFLT, and the ADC is always returned to idle after any calibration cycle. It is strongly recommended that ADC calibration is initiated at as low an ADC update rate as possible (high SF value in ADCFLT) to minimize the impact of ADC noise during calibration.

Using the Offset and Gain Calibration

If the Chop Bit ADCFLT[15] is enabled, then internal ADC offset errors are minimized and an offset calibration may not be required. If chopping is disabled however, an initial offset calibration is required and may need to be repeated, particularly after a large change in temperature.

A gain calibration, particularly in the context of the I-ADC (with internal PGA), may need to be carried out at all relevant system gain ranges depending on system accuracy requirements. If it is not possible to apply an external full-scale current on all gain ranges, then it is possible to apply a lower current and scale the result produced by the calibration. For example, apply a 50% current and then divide the ADC0GN value produced-by-two and write this value back into ADC0GN. Note that there is a lower limit to the input signal that can be applied for a system calibration because ADC0GN is only a 16-bit register. The input span (difference between the system zero-scale value and system full-scale value) should be greater than 40% of the nominal full-scale-input range, that is, $>40\%$ of $V_{REF}/gain$.

The on-chip Flash/EE memory can be used to store multiple calibration coefficients. These can be copied by user code

directly into the relevant calibration registers, as appropriate, based on the system configuration. In general, the simplest way to use the calibration registers is to let the ADC calculate the values required as part of the ADC automatic calibration modes.

A factory, or end-of-line calibration, for the I-ADC is a two-step procedure.

1. Apply 0A current. Configure the ADC in the required PGA setting, and so on, and write to ADCMDE[2:0] to perform a system zero-scale calibration. This writes a new offset calibration value into ADC0OF.
2. Apply a full-scale current for the selected PGA setting. Write to ADCMDE to perform a system full-scale calibration. This writes a new gain calibration value into ADC0GN.

Understanding the Offset and Gain Calibration Registers

The output of the average block in the ADC signal flow (described previously in the sections between the ADC Sinc3 Digital Filter Response section and the Using the Offset and Gain Calibration section) can be considered a fractional number with a span for a \pm full-scale input of approximately ± 0.75 . The span is less than ± 1.0 because there is attenuation in the modulator to accommodate some overrange capacity on the input signal. The exact value of the attenuation varies slightly from part-to-part, because of manufacturing tolerances.

The offset coefficient is read from the ADC0OF calibration register. This value is a 16-bit, twos complement number. The range of this number, in terms of the signal chain, is effectively ± 1.0 . Therefore, 1 LSB of the ADC0OF register is not the same as 1 LSB of ADC0DAT.

A positive value of ADC0OF indicates that when offset is subtracted from the output of the filter, a negative value is added. The nominal value of this register is 0x0000, indicating zero offset is to be removed. The actual offset of the ADC can vary slightly from part-to-part and at different PGA gains. The offset within the ADC is minimized if the chopping mode is active (ADCFLT[15] = 1).

The gain coefficient is a unitless scaling factor. The 16-bit value in this register is divided by 16,384 and then multiplied by the offset corrected value. The nominal value of this register equals 0x5555, corresponding to a multiplication factor of 1.3333. This scales the nominal ± 0.75 signal to produce a full-scale output signal of ± 1.0 which is checked for overflow/underflow and converted to twos complement or unipolar mode, as appropriate, before being output to the data register.

The actual gain, and the required scaling coefficient for zero gain error, varies slightly from part to part, at different PGA settings, and in normal/low power mode. The value downloaded into ADC0GN at power-on-reset represents the scaling factor for a PGA gain = 1. There is some level of gain error if this value is used at different PGA settings. User code

can overwrite the calibration coefficients or run ADC calibrations to correct the gain error at the current PGA setting.

In summary, the simplified ADC transfer function can be described as

$$ADC_{OUT} = \left[\frac{V_{IN} \times PGA}{V_{REF}} - ADCOF \right] \times \frac{ADCGN}{ADCGN_{NOM}}$$

This equation is valid for the voltage/temperature channel ADC.

For the current channel ADC

$$ADC_{OUT} = \left[\frac{V_{IN} \times PGA}{V_{REF}} - K \times ADCOF \right] \times \frac{ADCGN}{ADCGN_{NOM}}$$

where K is dependent on the PGA gain setting and ADC mode.

Normal Mode

For PGA gains of 1, 4, 8, 16, 32, and 64, the K factor is 1. For PGA gains of 2 and 128, the K factor is 2. For a PGA gain of 256, the K factor is 4. For a PGA gain of 512, the K factor is 8.

Low Power Mode

The PGA gain is set to 128 and the K factor is 32.

Low Power Plus Mode

The PGA gain is set to 512 and the K factor is 8.

In low power and low power plus modes, the K factor doubles if $(REG_AVDD)/2$ is used as the reference.

ADC DIAGNOSTICS

The ADuC7034 features diagnostic capability on both ADCs.

Current ADC Diagnostics

The ADuC7034 features the capability to detect open-circuit conditions on the application board. This is accomplished using the two current sources on IIN+ and IIN-; these are controlled via ADC0CON[14,13].

Note that these current sources have a tolerance of $\pm 30\%$. A PGA gain ≥ 2 ($ADC0CON[3:0] \geq 0001$) must be used when current sources are enabled.

Voltage/Temperature ADC Diagnostics

The ADuC7034 features the capability to detect open-circuit conditions on the voltage/temperature channel inputs. This is accomplished using the two current sources on VTEMP and GND_SW, controlled via ADC1CON[14, 13].

POWER SUPPLY SUPPORT CIRCUITS

The ADuC7034 incorporates two on-chip, low dropout (LDO) regulators that are driven directly from the battery voltage to generate a 2.6 V internal supply. This 2.6 V supply is then used as the supply voltage for the ARM7 MCU and peripherals including the precision analog circuits on-chip.

The digital LDO functions with two output capacitors, 2.2 μF and 0.1 μF in parallel, on REG_DVDD. Whereas, the analog LDO functions with an output capacitor (0.47 μF) on REG_AVDD.

The ESR of the output capacitor affects stability of the LDO control loop. An ESR of 5 Ω or less for frequencies above 32kHz is recommended to ensure the stability of the regulators.

Power-on-reset (POR), power supply monitor (PSM), and low voltage flag (LVF) functions are also integrated to ensure safe operation of the MCU as well as continuously monitoring the battery power supply.

The POR circuit is designed to handle all battery ramp rates and guarantee full functional operation of the Flash/EE memory-based MCU during power-on and power-down cycles.

As shown in Figure 28, once the supply voltage (on VDD), reaches a minimum operating voltage of 3 V, a POR signal keeps the ARM core in reset for 20 ms. This ensures that the regulated power supply voltage (REG_DVDD), supplied to the ARM core and associated peripherals, is above the minimum operational voltage to guarantee full functionality. A POR flag is set in the RSTSTA MMR to indicate a POR reset event has occurred.

The ADuC7034 also features a power supply monitor (PSM) function. When enabled through HVCFG0[3], the PSM continuously monitors the voltage at the VDD pin. If this voltage drops below 6.0 V typical, the PSM flag is automatically asserted and can, if the high voltage IRQ is enabled via IRQ/FIQEN[16], generate a system interrupt. An example of this operation is shown in Figure 28.

At voltages below the POR level, an additional low voltage flag can be enabled (HVCFG0[2]). It can be used to indicate that the contents of the SRAM remain valid after a reset event. The operation of the low voltage flag is shown in Figure 28. When enabled, the status of this bit can be monitored via HVMON[3]. If this bit is set, then the SRAM contents are valid. If this bit is cleared, then the SRAM contents can be corrupted.

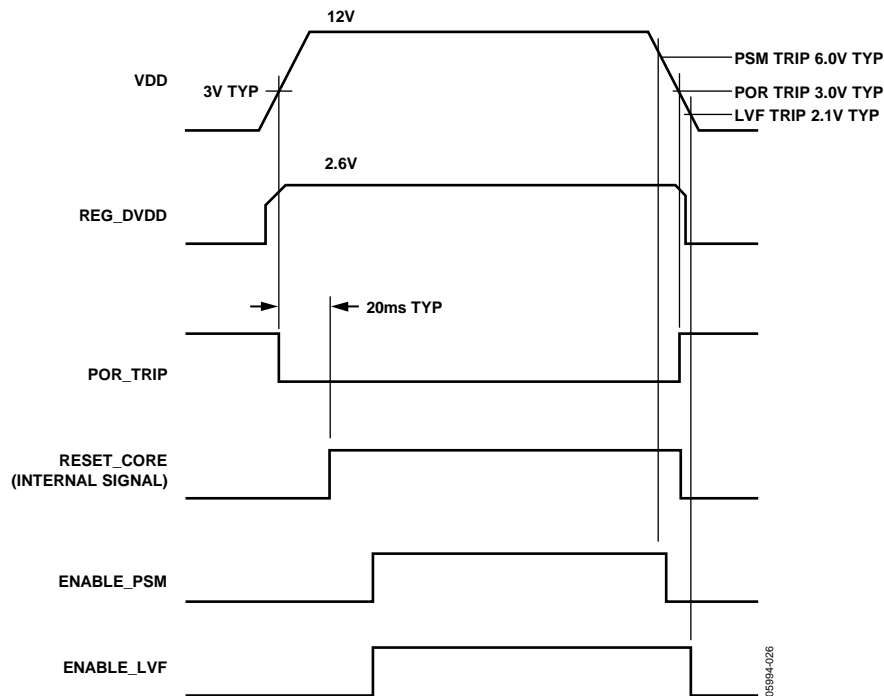

Figure 28. Typical Power-On Cycle

ADUC7034 SYSTEM CLOCKS

The ADuC7034 integrates a very flexible clocking system that can be clocked from one of three sources: an integrated on-chip precision oscillator, an integrated on-chip low power oscillator, or an external watch crystal. These three options are shown in Figure 29.

Each of the internal oscillators are divided by four to generate a clock frequency of 32.768 kHz. The PLL locks onto a multiple (625) of 32.768 kHz, supplied by either of the internal oscillators or the external crystal, to provide a stable 20.48 MHz clock for the system. The core can operate at this frequency, or at binary submultiples of it, thereby allowing power saving when peak performance is not required.

By default, the PLL is driven by the low power oscillator that generates a 20.48 MHz clock source. The ARM7TDMI core is driven by a CD divided clock derived from the output of the PLL.

By default, the CD divider is configured to divide the PLL output by two, thereby generating a core clock of 10.24 MHz. The divide factor can be modified to generate a binary weighted divider factor from 1 to 128 that can be altered dynamically by user code.

The ADC is driven by the output of the PLL, divided to give an ADC clock source of 512 kHz. In low power mode, the ADC clock source is switched from the standard 512 kHz to the low power 131 kHz oscillator.

Note that the low power oscillator drives both the watchdog and core wake-up timers through a divide-by-four circuit. A detailed block diagram of the ADuC7034 clocking system is shown in Figure 29.

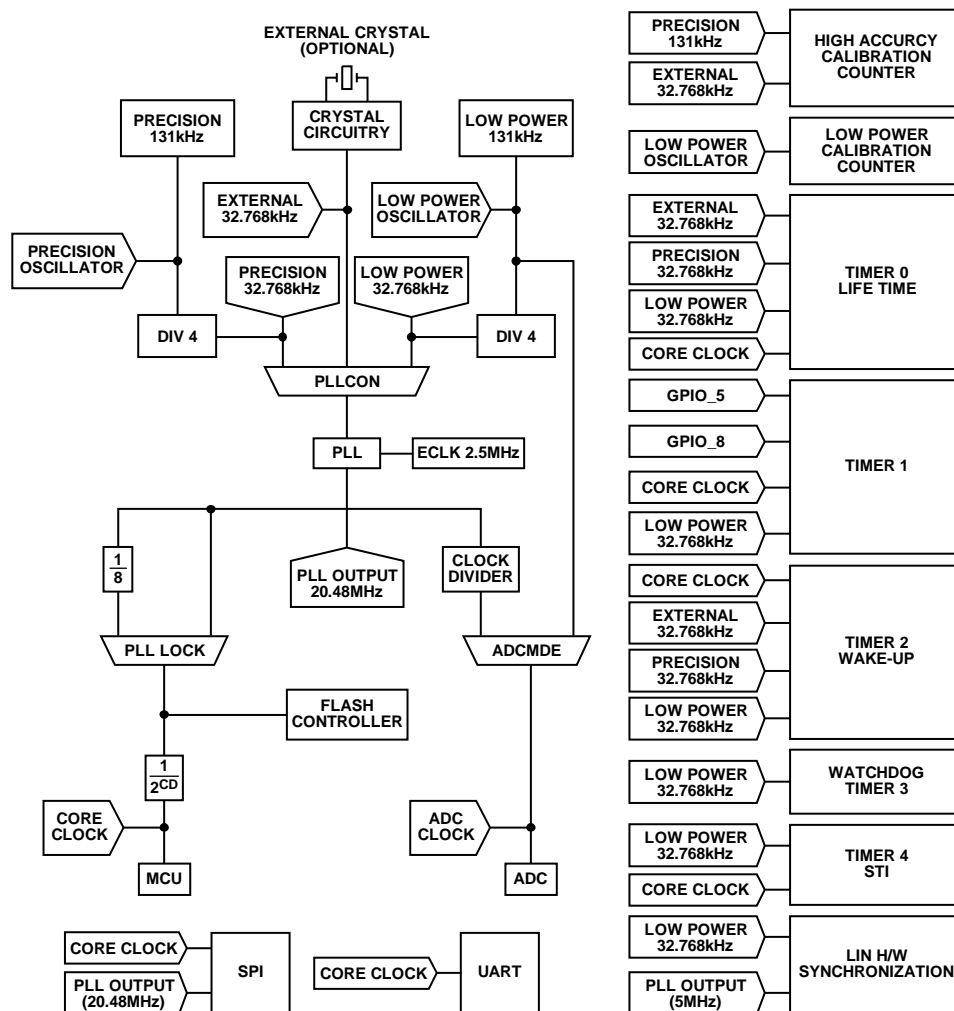

Figure 29. ADuC7034 System Clock Generation

The operating mode, clocking mode, and programmable clock divider are controlled using two MMRs, PLLCON and POWCON, and the status of the PLL is indicated by PLLSTA. PLLCON controls the operating mode of the clock system and POWCON controls both the core clock frequency and the power-down mode. PLLSTA indicates the presence of an oscillator on the XTAL1 pin, the PLL lock status, and the PLL interrupt.

It is recommended that before powering down the ADuC7034, switch the clock source for the PLL to the low power 131 kHz oscillator to reduce wake-up time. The low power oscillator is always active.

When the ADuC7034 wakes up from power down, the MCU core begins executing code as soon as the PLL begins oscillating. This occurs before the PLL has locked to a frequency of 20.48 MHz. To ensure the Flash/EE memory controller is executing with a valid clock, the controller is driven with a PLL output divide-by-eight clock source while the PLL is locking. When the PLL locks, the PLL output is switched from the PLL output divide-by-eight to the locked PLL output.

If user code requires an accurate PLL output, user code must poll the Lock Bit PLLSTA1 after wake-up before resuming normal code execution.

The PLL is locked within 2 ms if the PLL is clocked from an active clock source, such as a low power 131 kHz oscillator, after waking up.

PLLCON is a protected MMR with two 32-bit keys: PLLKEY0 (prewrite key) and PLLKEY1 (postwrite key).

PLLKEY0 = 0x000000AA

PLLKEY1 = 0x00000055

POWCON is a protected MMR with two 32-bit keys: POWKEY0 (pre write key) and POWKEY1 (post write key).

POWKEY0 = 0x00000001

POWKEY1 = 0x000000F4

An example of writing to both MMRs is as follows:

```
POWKEY0      =      0x01    //POWCON KEY
POWCON       =      0x00    //Full Power-down
POWKEY1      =      0xF4    //POWCON KEY
iA1*iA2      //dummy cycle to
clear the pipe line, where iA1 and iA2 are
defined as longs and are not 0

PLLKEY0      =      0xAA    //PLLCON KEY
PLLCON       =      0x0     //Switch to Low
Power Osc.
PLLKEY1      =      0x55    //PLLCON KEY
iA1*iA2      //dummy cycle to
prevent Flash/EE access during clock change
```

PLLSTA Register

Name: PLLSTA

Address: 0xFFFF0400

Default Value: 0xXX

Access: Read only

Function: This 8-bit register allows user code to monitor the lock state of the PLL and the status of the external crystal.

Table 43. PLLSTA MMR Bit Designations

Bit	Description
31 to 3	Reserved.
2	XTAL Clock, Read Only. This is a live representation of the current logic level on XTAL1. It allows the user to check to see if an external clock source is present. If present, this bit alternates high and low at a frequency of 32.768 kHz.
1	PLL Lock Status Bit, Read Only. Set when the PLL is locked and outputting 20.48 MHz. Clear when the PLL is not locked and outputting an f_{CORE} divide-by-8 clock source.
0	PLL Interrupt. Set if the PLL lock status bit signal goes low. Cleared by writing 1 to this bit.

PLLCON Prewrite Key PLLKEY0

Name: PLLKEY0
Address: 0xFFFF0410
Access: Write only
Key: 0x000000AA
Function: PLLCON is a keyed register that requires a 32-bit key value to be written before and after PLLCON. PLLKEY0 is the prewrite key.

PLLCON Postwrite Key PLLKEY1

Name: PLLKEY1
Address: 0xFFFF0418
Access: Write only
Key: 0x00000055
Function: PLLCON is a keyed register that requires a 32-bit key value to be written before and after PLLCON. PLLKEY1 is the postwrite key.

PLLCON Register

Name: PLLCON
Address: 0xFFFF0414
Default Value: 0x00
Access: Read/write
Function: This 8-bit register allows user code dynamically select the PLL source clock from three different oscillator sources.

Table 44. PLLCON MMR Bit Designations

Bit	Description
31 to 2	Reserved, these bits should be written as 0 by user code.
1 to 0	PLL Clock Source. ¹ 00 = lower power, 131 kHz oscillator. 01 = precision 131 kHz oscillator. 10 = external 32.768 kHz crystal. 11 = reserved.

¹ If the user code switches MCU clock sources, a dummy MCU cycle should be included after the clock switch is written to PLLCON.

POWCON Prewrite Key POWKEY0

Name: POWKEY0
Address: 0xFFFF0404
Access: Write only
Key: 0x00000001
Function: POWCON is a keyed register that requires a 32-bit key value to be written before and after POWCON. POWKEY0 is the prewrite key.

POWCON Postwrite Key POWKEY1

Name:	POWKEY1
Address:	0xFFFF040C
Access:	Write only
Key:	0x000000F4
Function:	POWCON is a keyed register that requires a 32-bit key value to be written before and after POWCON. POWKEY1 is the postwrite key.

POWCON Register

Name:	POWCON
Address:	0xFFFF0408
Default Value:	0x079
Access:	Read/write
Function:	This 8-bit register allows user code dynamically enter various low power modes and modify the CD divider that controls the speed of the ARM7TDMI core.

Table 45. POWCON MMR Bit Designations

Bit	Description
31 to 8	Reserved.
7	Precision 131 kHz Input Enable. Cleared by the user to power-down the precision 131 kHz input enable. Set by the user to enable the precision 131 kHz input enable. The precision 131 kHz oscillator must also be enabled using HVCFG0[6]. Setting this bit increases current consumption by approximately 50 μ A and should be disabled when not in use.
6	XTAL Power Down. Cleared by the user to power-down the external crystal circuitry. Set by the user to enable the external crystal circuitry.
5	PLL Power Down. Timer peripherals power down if driven from the PLL output clock. Timers driven from an active clock source remain in normal power mode. This bit is cleared to 0 to power-down the PLL. The PLL cannot be powered down if either the core or peripherals are enabled: Bit 3, Bit 4, and Bit 5 must be cleared simultaneously. Set by default, and set by hardware on a wake-up event.
4	Peripherals Power Down. The peripherals that are powered down by this bit are as follows: SRAM, Flash/EE memory and GPIO interfaces, and SPI and UART serial ports. Cleared to power-down the peripherals. The peripherals cannot be powered down if the core is enabled: Bit 3 and Bit 4 must be cleared simultaneously. LIN can still respond to wake-up events even if this bit is cleared. Set by default, and/or by hardware, on a wake-up event. Wake-Up Timer (Timer2) can still be active if driven from low power oscillator even if this bit is set.
3	Core Power Down. If user code powers down the MCU, include a dummy MCU cycle after the power-down command is written to POWCON. Cleared to power-down the ARM core. Set by default, and set by hardware on a wake-up event.
2 to 0	CD Core Clock Divider Bits. 000 = 20.48 MHz, 48.83 ns. 001 = 10.24 MHz, 97.66 ns. 010 = 5.12 MHz, 195.31 ns. 011 = 2.56 MHz, 390.63 ns. 100 = 1.28 MHz, 781.25 ns. 101 = 640 kHz, 1.56 μ s. 110 = 320 kHz, 3.125 μ s. 111 = 160 kHz, 6.25 μ s.

LOW POWER CLOCK CALIBRATION

The low power 131 kHz oscillator can be calibrated using either the precision 131 kHz oscillator or an external 32.768 kHz watch crystal. Two dedicated calibration counters and an oscillator trim register are used to implement this feature.

One counter, 9-bits wide, is clocked by an accurate clock oscillator, either the precision oscillator or external watch crystal. The second counter, 10-bits wide, is clocked by the low power oscillator, either directly at 131 kHz or through a divide-by-four block generating 32.768 kHz. The source for each calibration counter should be of the same frequency. The trim register (OSC0TRM) is an 8-bit wide register, of which, the lower four bits are user accessible trim bits. Increasing the value in OSC0TRM decreases the frequency of the low power oscillator; decreasing the value increases the frequency. Based on a nominal frequency of 131 kHz, the typical trim range is between 127 kHz to 135 kHz.

The clock calibration mode is configured and controlled by the following MMRs:

OSC0CON—control bits for calibration.

OSC0STA—calibration status register.

OSC0VAL0—9-bit counter, Counter 0.

OSC0VAL1—10-bit counter, Counter 1.

OSC0TRM—oscillator trim register.

An example calibration routine is shown in Figure 30. User code configures and enables the calibration sequence using OSC0CON. When the Precision Oscillator Calibration Counter OSC0VAL0 reaches 0x1FF, both counters are disabled.

User code then reads back the value of the low power oscillator calibration counter. There are three possible scenarios:

OSC0VAL0 = OSC0VAL1. No further action is required.

OSC0VAL0 > OSC0VAL1. The low power oscillator is running slow. OSC0TRM must be decreased.

OSC0VAL0 < OSC0VAL1. The low power oscillator is running fast. OSC0TRM must be increased.

When the OSC0TRM has been changed, the routine should be run again and the new frequency checked.

Using the internal, precision, 131 kHz oscillator, it takes approximately 4 ms to execute the calibration routine. If the external 32.768 kHz crystal is used, the time increases to 16 ms.

Prior to the clock calibration routine being started, it is required that the user switch to either the precision 131 kHz oscillator or the external 32.768 kHz watch crystal to serve as the PLL clock source. If this is not done, the PLL can lose lock each time OSC0TRM is modified. This increases the length of time it takes to calibrate the low power oscillator.

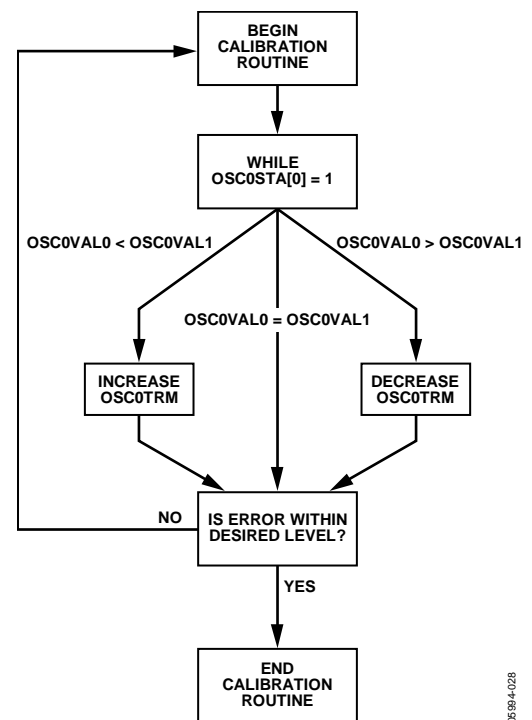

Figure 30. OSC0TRM Calibration Routine

05094-1028

OSC0TRM Register

Name: OSC0TRM
Address: 0xFFFF042C
Default Value: 0xX8
Access: Read/write
Function: This 8-bit register controls the low power oscillator trim.

Table 46. OSC0TRM MMR Bit Designations

Bit	Description
7 to 4	Reserved. Should be written as zeros.
3 to 0	User Trim Bits.

OSC0CON Register

Name: OSC0CON
Address: 0xFFFF0440
Default Value: 0x00
Access: Read/write
Function: This 8-bit register controls the low power oscillator calibration routine.

Table 47. OSC0CON MMR Bit Designations

Bit	Description
7 to 5	Reserved. Should be written as 0.
4	Calibration Source. Set to select external 32.768 kHz crystal. Cleared to select internal precision 131 kHz oscillator.
3	Calibration Reset. Set to reset the calibration counters and disable the calibration logic.
2	Set to Clear OSC0VAL1.
1	Set to Clear OSC0VAL0.
0	Calibration Enable. Set to begin calibration. Cleared to abort calibration.

OSCOSTA Register

Name: OSCOSTA

Address: 0xFFFF0444

Default Value: 0x00

Access: Read access only

Function: This 8-bit register gives the status of the low power oscillator calibration routine.

Table 48. OSCOSTA MMR Bit Designations

Bit	Description
7 to 2	Reserved.
1	Calibration Complete. Set by hardware on full completion of a calibration cycle. Cleared by a read of OSC0VAL1.
0	Set if calibration is in progress. Cleared if calibration is completed.

OSC0VAL0 Register

Name: OSC0VAL0

Address: 0xFFFF0448

Default Value: 0x00

Access: Read access only

Function: This 9-bit counter is clocked from either the 131 kHz precision oscillator or the 32.768 kHz external crystal.

OSC0VAL1 Register

Name: OSC0VAL1

Address: 0xFFFF044C

Default Value: 0x00

Access: Read access only

Function: This 10-bit counter is clocked from the low power, 131 kHz oscillator.

PROCESSOR REFERENCE PERIPHERALS

INTERRUPT SYSTEM

There are 16 interrupt sources on the ADuC7034 that are controlled by the interrupt controller. Most interrupts are generated from the on-chip peripherals such as the ADC, UART, and so on. The ARM7TDMI CPU core only recognizes interrupts as one of two types: a normal interrupt request (IRQ) and a fast interrupt request (FIQ). All the interrupts can be masked separately.

The control and configuration of the interrupt system is managed through nine interrupt-related registers, four dedicated to IRQ, four dedicated to FIQ. An additional MMR is used to select the programmed interrupt source. The bits in each IRQ and FIQ register represent the same interrupt source as described in Table 49.

IRQSTA/FIQSTA should be saved immediately upon entering the interrupt service routine (ISR) to ensure that all valid interrupt sources are serviced.

The interrupt generation route through the ARM7TDMI core is shown in Figure 31.

Consider the example of Timer0, which is configured to generate a timeout every 1 ms. After the first 1 ms timeout, FIQSIG/IRQSIG[2] is set and can only be cleared by writing to T0CLR. If Timer0 is not enabled in either IRQEN or FIQEN, then FIQSTA/IRQSTA[2] is not set and an interrupt does not occur. However, if Timer0 is enabled in either IRQEN or FIQEN, then either FIQSTA/IRQSTA[2] is set or an interrupt (either an FIQ or IRQ) occurs.

Note that the IRQ and FIQ interrupt bit definitions in the CPSR only control interrupt recognition by the ARM core, not by the peripherals. For example, if Timer2 is configured to generate an IRQ via IRQEN, the IRQ interrupt bit is set (disabled) in the CPSR and the ADuC7034 is powered down. When an interrupt occurs, the peripherals are woken, but the ARM core remains powered down. This is equivalent to POWCON = 0x71. The ARM core can only be powered up by a reset event if this occurs.

Table 49. IRQ/FIQ MMRs Bit Designations

Bit	Description	Comments
0	All interrupts OR'ed (FIQ only)	
1	SWI: not used in IRQEN/CLR and FIQEN/CLR	
2	Timer0	See the Timer0—Lifetime Timer section.
3	Timer1	See the Timer1 section.
4	Timer2 or wake-up timer	See the Timer2 or Wake-Up Timer section.
5	Timer3 or watchdog timer	See the Timer3 or Watchdog Timer section.
6	Timer4 or STI timer	See the Timer4 or STI Timer section.
7	LIN Hardware	See the LIN (Local Interconnect Network) Interface section.
8	Flash/EE interrupt	See the Flash/EE Control Interface section.
9	PLL lock	See the ADuC7034 System Clocks section.
10	ADC	See the 16-Bit, Σ - Δ Analog-to-Digital Converters section.
11	UART	See the UART Serial Interface section.
12	SPI master	See the Serial Peripheral Interface section.
13	XIRQ0 (GPIO IRQ0)	See the General-Purpose I/O section.
14	XIRQ1 (GPIO IRQ1)	See the General-Purpose I/O section.
15	Reserved	
16	IRQ3 high voltage IRQ	High Voltage Interrupt, see the High Voltage Peripheral Control Interface section.
17	SPI slave	See the Serial Peripheral Interface section.
18	XIRQ4 (GPIO IRQ4)	See the General-Purpose I/O section.
19	XIRQ5 (GPIO IRQ5)	See the General-Purpose I/O section.

IRQ

The IRQ is the exception signal to enter the IRQ mode of the processor. It is used to service general-purpose interrupt handling of internal and external events.

All 32 bits are logically OR'ed to create a single IRQ signal to the ARM7TDMI core. The four 32-bit registers dedicated to IRQ follow.

IRQSIG

IRQSIG reflects the status of the different IRQ sources. If a peripheral generates an IRQ signal, the corresponding bit in the IRQSIG is set, otherwise it is cleared. The IRQSIG bits are cleared when the interrupt in the particular peripheral is cleared. All IRQ sources can be masked in the IRQEN MMR. IRQSIG is read only.

IRQEN

IRQEN provides the value of the current enable mask. When a bit is set to 1, the corresponding source request is enabled to create an IRQ exception. When a bit is set to 0, the corresponding source request is disabled or masked which does not create an IRQ exception. The IRQEN register cannot be used to disable an interrupt.

IRQCLR

IRQCLR is a write only register that allows the IRQEN register to clear in order to mask an interrupt source. Each bit set to 1 clears the corresponding bit in the IRQEN register without affecting the remaining bits. The pair of registers, IRQEN and IRQCLR, allow independent manipulation of the enable mask without requiring an atomic read-modify-write.

IRQSTA

IRQSTA is a read only register that provides the current enabled IRQ source status (effectively a logic AND of the IRQSIG and IRQEN bits). When set to 1, that source generates an active IRQ request to the ARM7TDMI core. There is no priority encoder or interrupt vector generation. This function is implemented in software in a common interrupt handler routine.

Fast Interrupt Request (FIQ)

The fast interrupt request (FIQ) is the exception signal to enter the FIQ mode of the processor. It is provided to service data transfer or communication channel tasks with low latency. The FIQ interface is identical to the IRQ interface and provides the second level interrupt (highest priority). Four 32-bit registers are dedicated to FIQ: FIQSIG, FIQEN, FIQCLR, and FIQSTA.

Bit 31 to Bit 1 of FIQSTA are logically OR'ed to create the FIQ signal to the core and to Bit 0 of both the FIQ and IRQ registers (FIQ source).

The logic for FIQEN and FIQCLR does not allow an interrupt source to be enabled in both IRQ and FIQ masks. A bit set to 1 in FIQEN clears, as a side effect, the same bit in IRQEN. Likewise, a bit set to 1 in IRQEN clears, as a side effect, the same bit in FIQEN. An interrupt source can be disabled in both IRQEN and FIQEN masks.

Programmed Interrupts

Because the programmed interrupts are not maskable, they are controlled by another register, SWICFG, that writes into both IRQSTA and IRQSIG registers and/or the FIQSTA and FIQSIG registers at the same time.

The 32-bit register dedicated to software interrupt is SWICFG described in Table 50. This MMR allows the control of a programmed source interrupt.

Table 50. SWICFG MMR Bit Designations

Bit	Description
31 to 3	Reserved.
2	Programmed Interrupt FIQ. Setting/clearing this bit corresponds to setting/clearing Bit 1 of FIQSTA and FIQSIG.
1	Programmed Interrupt IRQ. Setting/clearing this bit corresponds to setting/clearing Bit 1 of IRQSTA and IRQSIG.
0	Reserved.

Note that any interrupt signal must be active for at least the minimum interrupt latency time, to be detected by the interrupt controller and to be detected by the user in the IRQSTA/FIQSTA register.

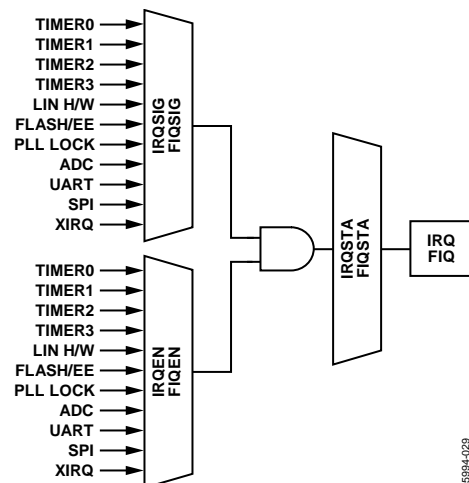

Figure 31. Interrupt Structure

05934-029

TIMERS

The ADuC7034 features five general-purpose timer/counters.

- Timer0, or lifetime timer
- Timer1
- Timer2 or wake-up timer
- Timer3 or watchdog timer
- Timer4 or STI timer

The five timers in their normal mode of operation can either be free running or periodic.

In free running mode, the counter decrements/increments from the maximum/minimum value until zero/full scale and starts again at the maximum/minimum value.

In periodic mode, the counter decrements/increments from the value in the load register (TxLD MMR,) until zero/full scale and starts again at the value stored in the load register. Note that the TxLD MMR should be configured before the TxCON MMR.

The value of a counter can be read at any time by accessing its value register (TxVAL). Timers are started by writing in the control register of the corresponding timer (TxCON).

In normal mode, an IRQ is generated each time the value of the counter reaches zero (if counting down) or full scale (if counting up). An IRQ can be cleared by writing any value to the clear register of the particular timer (TxCLRI).

Table 51. Timer Event Capture

Bit	Description
0	Timer0 or lifetime timer
1	Timer1
2	Timer2 or wake-up timer
3	Timer3 or watchdog timer
4	Timer4 or STI timer
5	LIN hardware
6	Flash/EE interrupt
7	PLL lock
8	ADC
9	UART
10	SPI Master
11	XIRQ0 (GPIO_0)
12	XIRQ1 (GPIO_5)
13	Reserved
14	IRQ3 high voltage interrupt
15	SPI Slave
16	XIRQ4 (GPIO_7), see the General-Purpose I/O section
17	XIRQ5 (GPIO_8), see the General-Purpose I/O section

TIMER0—LIFETIME TIMER

Timer0 is a general-purpose, 48-bit count up, or a 16-bit count up/down timer with a programmable prescaler. Timer0 can be clocked from either the core clock or the low power 32.768 kHz oscillator with a prescaler of 1, 16, 256, or 32,768. This gives a minimum resolution of 48.83 ns when the core is operating at 20.48 MHz with a prescaler of 1.

In 48-bit mode, Timer0 counts up from zero. The current counter value can be read from T0VAL0 and T0VAL1.

In 16-bit mode, Timer0 can count up or count down. A 16-bit value can be written to TOLD to load into the counter. The current counter value is read from T0VAL0. Timer0 has a capture register (T0CAP) triggered by a selected IRQ source initial assertion. When triggered, the current timer value is copied to T0CAP and the timer continues running. This feature can be used to determine the assertion of an event with more accuracy than by servicing an interrupt alone.

Timer0 reloads the value from TOLD when Timer0 overflows.

The Timer0 interface consists of six MMRS.

- TOLD is a 16-bit register holding the 16-bit value that is loaded into the counter. TOLD is only available in 16-bit mode.
- T0CAP is a 16-bit register that holds the 16-bit value captured by an enabled IRQ event. T0CAP is only available in 16-bit mode.
- T0VAL0/T0VAL1 are 16-bit and 32-bit registers that hold the 16 least significant bits (LSBs) and 32 most significant bits (MSBs), respectively. T0VAL0 and T0VAL1 are read only. In 16-bit mode, 16-bit T0VAL0 is used. In 48-bit mode, both 16-bit T0VAL0 and 32-bit T0VAL1 are used.

- T0CLRI is an 8-bit register. Writing any value to this register clears the interrupt. T0CLRI is only available in 16-bit mode.
- T0CON is the configuration MMR described in Table 52.

Timer0 Value Registers (T0VAL0/T0VAL1)

Name:	T0VAL0/T0VAL1
Address:	0xFFFFF0304, 0xFFFFF0308
Default Value:	0x0000, 0x00000000
Access:	Read access only
Function:	T0VAL0 and T0VAL1 are 16-bit and 32-bit registers that hold the 16 LSBs and 32 MSBs, respectively. T0VAL0 and T0VAL1 are read only. In 16-bit mode, 16-bit T0VAL0 is used. In 48-bit mode, both 16-bit T0VAL0 and 32-bit T0VAL1 are used.

Timer0 Capture Register

Name:	T0CAP
Address:	0xFFFFF0314
Default Value:	0x0000
Access:	Read access only
Function:	This is a 16-bit register that holds the 16-bit value captured by an enabled IRQ event. Available only in 16-bit mode.

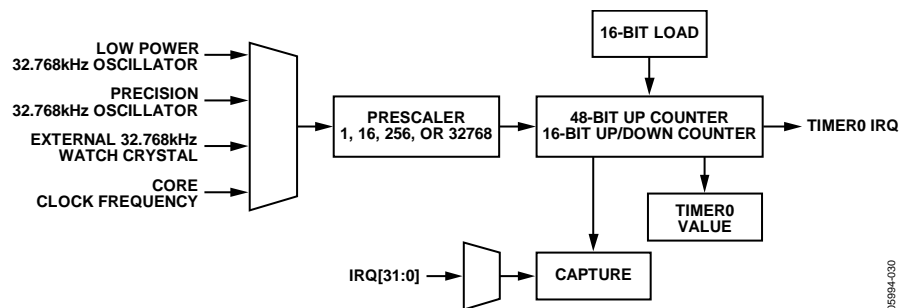

Figure 32. Timer0 Block Diagram

05684-030

Timer0 Control Register

Name:	T0CON
Address:	0xFFFF030C
Default Value:	0x00000000
Access:	Read/write
Function:	The 32-bit MMR configures the mode of operation for Timer0.

Table 52. T0CON MMR Bit Designations

Bit	Description
31 to 18	Reserved.
17	Event Select Bit. Set by user to enable time capture of an event. Cleared by user to disable time capture of an event.
16 to 12	Event Select Range (0 to 31). The events are as described in Table 51.
11	Reserved.
10 to 9	Clock Select. 00 = core clock (default). 01 = low power (32.768 kHz) oscillator. 10 = external 32.768 kHz watch crystal. 11 = precision 32.768 kHz oscillator.
8	Count Up. Available in 16-bit mode only. Set by user for Timer0 to count up. Cleared by user for Timer0 to count down (default).
7	Timer0 Enable Bit. Set by user to enable Timer0. Cleared by user to disable Timer0 (default).
6	Timer0 Mode. Set by user to operate in periodic mode. Cleared by user to operate in free running mode (default).
5	Reserved.
4	Timer0 Mode of Operation. 0 = 16-bit operation (default). 1 = 48-bit operation.
3 to 0	Prescaler. 0000 = source clock/1 (default). 0100 = source clock/16. 1000 = source clock/256. 1111 = source clock/32,768.

Timer0 Load Registers

Name: T0LD

Address: 0xFFFF0300

Default Value: 0x0000

Access: Read/write

Function: T0LD0 is the 16-bit register holding the 16-bit value that is loaded into the counter. Available in 16-bit mode only.

Timer0 Clear Register

Name: T0CLRI

Address: 0xFFFF0310

Access: Write only

Function: This 16-bit, write only MMR is written (with any value) by user code to clear the interrupt.

TIMER1

Timer1 is a 32-bit general-purpose timer, count down or count up, with a programmable prescaler. The prescaler source can be the low power 32.768 kHz oscillator, the core clock, or from one of two external GPIOs. This source can be scaled by a factor of 1, 16, 256, or 32,768. This gives a minimum resolution of 48.83 ns when operating at CD zero, the core is operating at 20.48 MHz, and with a prescaler of 1 (ignoring the external GPIOs).

The counter can be formatted as a standard 32-bit value or as hours:minutes:seconds:hundredths.

Timer1 has a capture register (T1CAP) that is triggered by a selected IRQ source initial assertion. When triggered, the current timer value is copied to T1CAP, and the timer continues to run. This feature can be used to determine the assertion of an event with increased accuracy.

The Timer1 interface consists of five MMRS.

- T1LD, T1VAL, and T1CAP are 32-bit registers and hold 32-bit unsigned integers. T1VAL and T1CAP are read only.
- T1CLRI is an 8-bit register. Writing any value to this register clears the Timer1 interrupt.
- T1CON is the configuration MMR described in Table 53.

Timer1 features a postscaler allowing the user to count between 1 and 256 the number of Timer1 timeouts. To activate the postscaler, the user sets Bit 18 and writes the desired number to count into Bits[24:31] of T1CON. When that number of timeouts has been reached, Timer1 can generate an interrupt if T1CON[18] is set.

Note that if the part is in a low power mode, and Timer1 is clocked from the GPIO or low power oscillator source, then Timer1 continues to operate.

Timer1 reloads the value from T1LD when Timer1 overflows.

Timer1 Load Registers

Name: T1LD
Address: 0xFFFF0320
Default Value: After a reset this register contains the upper half of the assembly lot ID
Access: Read/write
Function: T1LD is a 32-bit register that holds the 32-bit value that is loaded into the counter.

Timer1 Clear Register

Name: T1CLRI
Address: 0xFFFF032C
Access: Write only
Function: This 32-bit, write only MMR is written (with any value) by user code to clear the interrupt.

Timer1 Value Register

Name: T1VAL
Address: 0xFFFF0324
Default Value: 0xFFFFFFFF
Access: Read only
Function: T1VAL is a 32-bit register that holds the current value of Timer1.

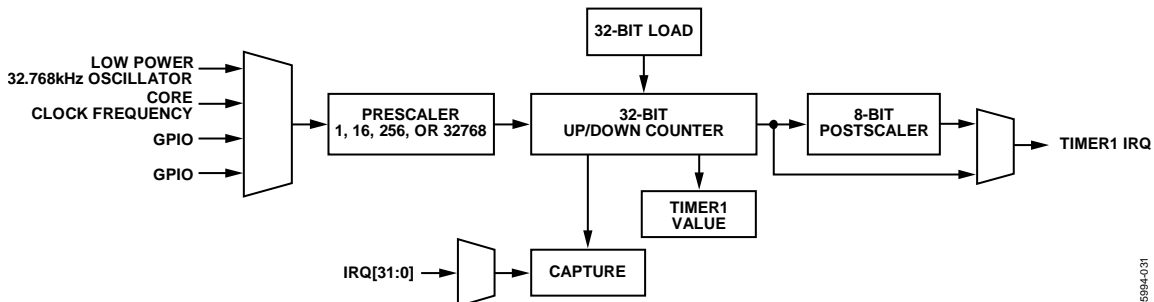

Figure 33. Timer1 Block Diagram

05894-031

Timer1 Capture Register

Name: T1CAP
Address: 0xFFFF0330
Default Value: 0x00000000
Access: Read only
Function: This 32-bit register holds the 32-bit value captured by an enabled IRQ event.

Timer1 Control Register

Name: T1CON
Address: 0xFFFF0328
Default Value: 0x01000000
Access: Read/write
Function: This 32-bit MMR configures the mode of operation of Timer1.

Table 53. T1CON MMR Bit Designations

Bit	Description
31 to 24	8-Bit Postscaler. By writing to these eight bits, a value is written to the postscaler. Writing 0 is interpreted as a 1. By reading these eight bits, the current value of the counter is read.
23	Timer1 Enable Postscaler. Set to enable the Timer1 postscaler. If enabled, interrupts are generated after T1CON[31:24] periods as defined by T1LD. Cleared to disable the Timer1 postscaler.
22 to 20	Reserved. These bits are reserved and should be written as 0 by user code.
19	Postscaler Compare Flag. Read only. Set if the number of Timer1 overflows is equal to the number written to the postscaler.
18	Timer1 Interrupt Source. Set to select interrupt generation from the postscaler counter. Cleared to select interrupt generation directly from Timer1.
17	Event Select Bit. Set by user to enable time capture of an event. Cleared by user to disable time capture of an event.
16 to 12	Event select range, 0 to 31. The events are described in Table 51.
11 to 9	Clock Select. 000 = core clock (default). 001 = low power 32.768 kHz oscillator. 010 = GPIO_8. 011 = GPIO_5.
8	Count Up. Set by user for Timer1 to count up. Cleared by user for Timer1 to count down (default).
7	Timer1 Enable Bit. Set by user to enable Timer1. Cleared by user to disable Timer1 (default).
6	Timer1 Mode. Set by user to operate in periodic mode. Cleared by user to operate in free running mode (default).

Bit	Description
5 to 4	Format. 00 = binary (default). 01 = reserved. 10 = hours:minutes:seconds:hundredths (23 hours to 0 hours). 11 = hours:minutes:seconds:hundredths (255 hours to 0 hours).
3 to 0	Prescaler. 0000 = source clock/1 (default). 0100 = source clock/16. 1000 = source clock/256. 1111 = source clock/32,768.

TIMER2 OR WAKE-UP TIMER

Timer2 is a 32-bit wake-up timer, count-down or count-up, with a programmable prescaler. The prescaler is clocked directly from one of four clock sources, namely, the core clock (which is the default selection), the low power 32.768 kHz oscillator, external 32.768 kHz watch crystal, or the precision 32.768 kHz oscillator. The selected clock source can be scaled by a factor of 1, 16, 256 or 32,768. The wake-up timer continues to run when the core clock is disabled. This gives a minimum resolution of 48.83 ns when operating at CD zero, the core is operating at 20.48 MHz with a prescaler of 1.

The counter can be formatted as a plain 32-bit value or as hours:minutes:seconds:hundredths.

Timer2 reloads the value from T2LD when Timer2 overflows.

The Timer2 interface consists of four MMRS.

- T2LD and T2VAL are 32-bit registers and hold 32-bit unsigned integers. T2VAL is read only.
- T2CLRI is an 8-bit register. Writing any value to this register clears the Timer2 interrupt.
- T2CON is the configuration MMR described in Table 54.

Timer2 Load Registers

Name: T2LD

Address: 0xFFFF0340

Default Value: 0x00000000

Access: Read/write

Function: T2LD is a 32-bit register that holds the 32-bit value that is loaded into the counter.

Timer2 Clear Register

Name: T2CLRI

Address: 0xFFFF034C

Access: Write only

Function: This 32-bit, write only MMR is written (with any value) by user code to clear the interrupt.

Timer2 Value Register

Name: T2VAL

Address: 0xFFFF0344

Default Value: 0xFFFFFFFF

Access: Read only

Function: T2VAL is a 32-bit register that holds the current value of Timer2.

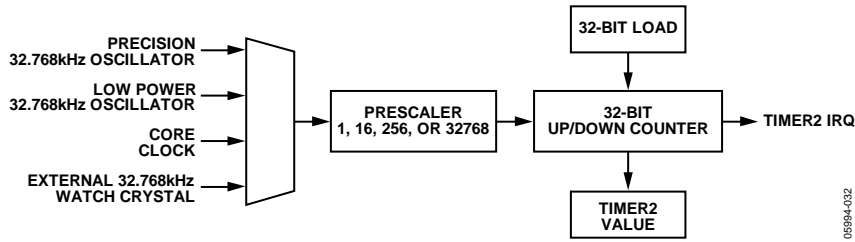

Figure 34. Timer2 Block Diagram

05994-032

Timer2 Control Register

- Name:** T2CON
- Address:** 0xFFFF0348
- Default Value:** 0x0000
- Access:** Read/write
- Function:** This 16-bit MMR configures the mode of operation of Timer2.

Table 54. T2CON MMR Bit Designations

Bit	Description
15 to 11	Reserved.
10 to 9	Clock Source Select. 00 = core clock (default). 01 = low power (32.768 kHz) oscillator. 10 = external 32.768 kHz watch crystal. 11 = precision 32.768 kHz oscillator.
8	Count Up. Set by user for Timer2 to count up. Cleared by user for Timer2 to count down (default).
7	Timer2 Enable Bit. Set by user to enable Timer2. Cleared by user to disable Timer2 (default).
6	Timer2 Mode. Set by user to operate in periodic mode. Cleared by user to operate in free running mode (default).
5 to 4	Format. 00 = binary (default). 01 = reserved. 10 = hours:minutes:seconds:hundredths (23 hours to 0 hours). This is only valid with a 32 kHz clock. 11 = hours:minutes:seconds:hundredths (255 hours to 0 hours). This is only valid with a 32 kHz clock.
3 to 0	Prescaler. 0000 = source clock/1 (default). 0100 = source clock/16. 1000 = source clock/256. This setting should be used in conjunction with Timer2 in the format hours:minutes:seconds:hundredths. See Format 10 and Format 11 listed with Bits[5:4] in this table. 1111 = source clock/32,768.

TIMER3 OR WATCHDOG TIMER

Timer3 has two modes of operation, normal mode and watchdog mode. The watchdog timer is used to recover from an illegal software state. When enabled, it requires periodic servicing to prevent it from forcing a reset of the processor.

Timer3 reloads the value from T3LD when Timer3 overflows.

Normal Mode

The Timer3 in normal mode is identical to Timer0 in 16-bit mode of operation, except for the clock source. The clock source is the low power, 32.768 kHz oscillator scalable by a factor of 1, 16, or 256.

Watchdog Mode

Watchdog mode is entered by setting T3CON[5]. Timer3 decrements from the timeout value present in the T3LD register until zero. The maximum timeout is 512 seconds, using a maximum prescaler/256 and full-scale in T3LD.

User software should not configure a timeout period of less than 30 ms. This is to avoid any conflict with Flash/EE memory page erase cycles that require 20 ms to complete a single page erase cycle and kernel execution.

If T3VAL reaches 0, a reset or an interrupt occurs, depending on T3CON[1]. To avoid a reset or an interrupt event, any value must be written to T3CLRI before T3VAL reaches zero. This reloads the counter with T3LD and begins a new timeout period.

When watchdog mode is entered, T3LD and T3CON are write protected. These two registers cannot be modified until a power-on reset event resets the watchdog timer. After any other reset event, the watchdog timer continues to count. The watchdog timer should be configured in the initial lines of user code to avoid an infinite loop of watchdog resets. User software should only configure a minimum timeout period of 30 ms.

Timer3 is automatically halted during JTAG debug access and only recommences counting after JTAG has relinquished control of the ARM7 core. By default, Timer3 continues to count during power-down. This can be disabled by setting Bit 0 in T3CON. It is recommended to use the default value, that is, that the watchdog timer continues to count during power-down.

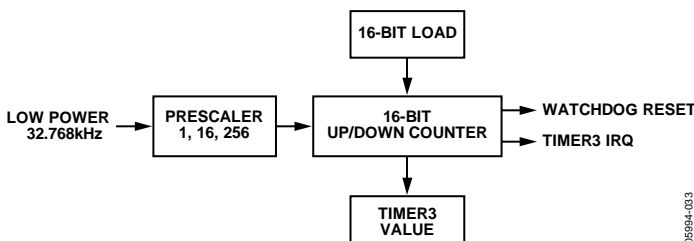

Figure 35. Timer3 Block Diagram

05984-033

Timer3 Interface

Timer3 interface consists of four MMRs.

T3CON is the configuration MMR described in Table 55.

T3LD and T3VAL are 16-bit registers (Bit 0 to Bit 15) and hold 16-bit unsigned integers. T3VAL is read only.

T3CLRI is an 8-bit register. Writing any value to this register clears the Timer3 interrupt in normal mode or resets a new timeout period in watchdog mode.

Timer3 Load Register

Name:	T3LD
Address:	0xFFFF0360
Default Value:	0x0040
Access:	Read/write
Function:	This 16-bit MMR holds the Timer3 reload value.

Timer3 Value Register

Name:	T3VAL
Address:	0xFFFF0364
Default Value:	0x0040
Access:	Read only
Function:	This 16-bit, read only MMR holds the current Timer3 count value.

Timer3 Clear Register

Name:	T3CLRI
Address:	0xFFFF036C
Access:	Write only
Function:	This 16-bit, write only MMR is written (with any value) by user code to refresh (reload) Timer3 in watchdog mode to prevent a watchdog timer reset event.

Timer3 Control Register**Name:** T3CON**Address:** 0xFFFF0368**Default Value:** 0x0000**Access:** Read/write**Function:** The 16-bit MMR configures the mode of operation of Timer3 as is described in detail in Table 55.**Table 55. T3CON MMR Bit Designations**

Bit	Description
15 to 9	Reserved. These bits are reserved and should be written as 0 by user code.
8	Count Up/Count Down Enable. Set by user code to configure Timer3 to count up. Cleared by user code to configure Timer3 to count down.
7	Timer3 Enable. Set by user code to enable Timer3. Cleared by user code to disable Timer3.
6	Timer3 Operating Mode. Set by user code to configure Timer3 to operate in periodic mode. Cleared by user to configure Timer3 to operate in free running mode.
5	Watchdog Timer Mode Enable. Set by user code to enable watchdog mode. Cleared by user code to disable watchdog mode.
4	Reserved. This bit is reserved and should be written as 0 by user code.
3 to 2	Timer3 Clock (32.768 kHz) Prescaler. 00 = source clock/1 (default). 01 = source clock/16. 10 = source clock/256. 11 = reserved.
1	Watchdog Timer IRQ Enable. Set by user code to produce an IRQ instead of a reset when the watchdog reaches 0. Cleared by user code to disable the IRQ option.
0	PD_OFF. Set by the user code to stop Timer3 when the peripherals are powered down using Bit 4 in the POWCON MMR. Cleared by the user code to enable Timer3 when the peripherals are powered down using Bit 4 in the POWCON MMR.

TIMER4 OR STI TIMER

Timer4 is a general-purpose, 16-bit, count up/count down timer with a programmable prescaler. Timer4 can be clocked from the core clock or the low power 32.768 kHz oscillator with a prescaler of 1, 16, 256, or 32,768.

Timer4 has a capture register (T4CAP) that can be triggered by a selected IRQ source initial assertion. Once triggered, the current timer value is copied to T4CAP, and the timer continues running. This feature can be used to determine the assertion of an event with increased accuracy.

Timer4 can also be used to drive the serial test interface (STI) peripheral.

Timer4 interface consists of five MMRs.

- T4LD, T4VAL, and T4CAP are 16-bit registers and hold 16-bit unsigned integers. T4VAL and T4CAP are read only.
- T4CLRI is an 8-bit register. Writing any value to this register clears the interrupt.
- T4CON is the configuration MMR described in Table 56.

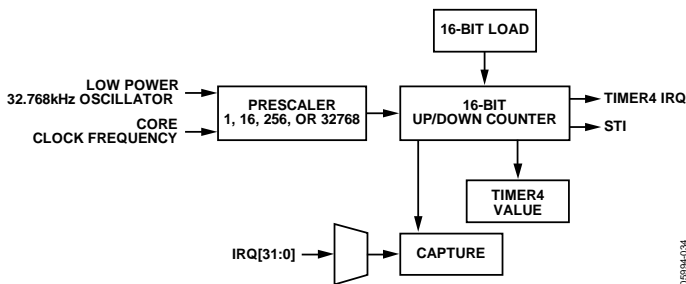

Figure 36. Timer4 Block Diagram

0594434

Timer4 Load Registers

Name: T4LD

Address: 0xFFFFF0380

Default Value: 0x000000

Access: Read/write

Function: T4LD 16-bit register holds the 16-bit value that is loaded into the counter.

Timer4 Clear Register

Name: T4CLRI

Address: 0xFFFFF038C

Access: Write only

Function: This 8-bit, write only MMR is written (with any value) by user code to clear the interrupt.

Timer4 Value Register

Name: T4VAL

Address: 0xFFFFF0384

Default Value: 0xFFFF

Access: Read only

Function: T4VAL is a 16-bit register that holds the current value of Timer4.

Time4 Capture Register

Name: T4CAP

Address: 0xFFFFF0390

Default Value: 0x0000

Access: Read only

Function: This is a 16-bit register that holds the 32-bit value captured by an enabled IRQ event.

Timer4 Control Register

Name: T4CON

Address: 0xFFFFF0388

Default Value: 0x00000000

Access: Read/write

Function: This 32-bit MMR configures the mode of operation of Timer4.

Table 56. T4CON MMR Bit Designations

Bit	Description
31 to 18	Reserved.
17	Event Select Bit. Set by user to enable time capture of an event. Cleared by user to disable time capture of an event.
16 to 12	Event Select Range, 0 to 31. The events are described in Table 51.
11 to 10	Reserved.
9	Clock Select. 0 = core clock (default). 1 = low power 32.768 kHz oscillator.
8	Count Up. Set by user for Timer4 to count up. Cleared by user for Timer4 to count down (default).
7	Timer4 Enable Bit. Set by user to enable Timer0. Cleared by user to disable Timer0 (default).
6	Timer4 Mode. Set by user to operate in periodic mode. Cleared by user to operate in free running mode. Default mode.
5 to 4	Reserved.
3 to 0	Prescaler. 0000 = source clock/1 (default). 0100 = source clock/16. 1000 = source clock/256. 1111 = source clock/32,768.

GENERAL-PURPOSE I/O

The ADuC7034 features nine general-purpose bidirectional input/output (GPIO) pins. In general, many of the GPIO pins have multiple functions that can be configured by user code. By default, the GPIO pins are configured in GPIO mode. All GPIO pins have an internal pull-up resistor with a sink capability of 0.8 mA and a source capability of 0.1 mA.

The nine GPIOs are grouped into three ports: Port0, Port1, and Port2. Port0 is five bits wide. Port1 and Port2 are both two bits wide. The GPIO assignment within each port is detailed in Table 57. A typical GPIO structure is shown Figure 37.

External interrupts are present on GPIO_0, GPIO_5, GPIO_7, and GPIO_8. These interrupts are level triggered and are active high. These interrupts are not latched; therefore, the interrupt source must be present until either IRQSTA or FIQSTA are interrogated. The interrupt source must be active for at least one CD divided core clock to guarantee recognition.

All port pins are configured and controlled by four sets (one set for each port) of four port-specific MMRs as follows:

GPxCON: Portx control register

GPxDAT: Portx configuration and data register

GPxSET: Data Set Portx

GPxCLR: Data Clear Portx

where x corresponds to the port number (0, 1, or 2).

During normal operation, user code can control the function and state of the external GPIO pins by these general-purpose registers. All GPIO pins retain their external level (high or low) during power-down (POWCON) mode.

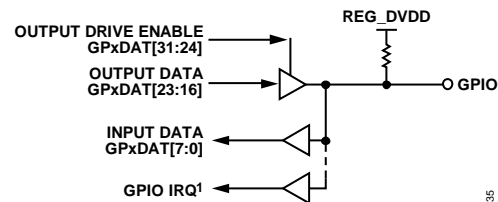

¹ONLY AVAILABLE ON GP0, GP5, GP7, AND GP8.

05984-035

Figure 37. ADuC7034 GPIO

Table 57. External GPIO Pin to Internal Port Signal Assignments

Port	GPIO PIN	PORT SIGNAL	Functionality (Defined by GPxCON)
Port0	GPIO_0	P0.0	General-Purpose I/O.
		IRQ0	\overline{SS} , Slave Select I/O for SPI.
	GPIO_1	P0.1	General-Purpose I/O; SCLK, Serial Clock I/O for SPI.
	GPIO_2	P0.2	General-Purpose I/O; MISO, Master Input, Slave Output for SPI.
	GPIO_3	P0.3	General-Purpose I/O; MOSI, Master Output, Slave Input for SPI.
	GPIO_4	P0.4	General-Purpose I/O; ECLK, a 2.56 MHz Clock Output.
	P0.5 ¹	High Voltage Serial Interface.	
	P0.6 ¹	High Voltage Serial Interface.	
Port1	GPIO_5	P1.0	General Purpose I/O.
		IRQ1	RxD Pin for UART.
	GPIO_6	P1.1	General-Purpose I/O. TxD Pin for UART.
Port2	GPIO_7	Port 2.0	General-Purpose I/O.
		IRQ4	LIN/BSD Output Pin. Used to read directly from LIN pin for conformance testing.
	GPIO_8	P2.1	General-Purpose I/O.
		IRQ5	LIN/BSD HV Input Pin. Used to directly drive LIN pin for conformance testing.
	GPIO_11 ²	P2.4 ²	General-Purpose I/O; LIN/BSD Input Pin.
	GPIO_12 ²	P2.5 ²	General-Purpose I/O; LIN/BSD Output Pin.
GPIO_13 ¹	P2.6 ¹	General-Purpose I/O; STI Data Output.	

¹ These signals are internal signals only and do not appear on an external pin. These pins are used along with HVCON as the 2-wire interface to the high voltage interface circuits.

² These pins/signals are internal signals only and do not appear on an external pin. Both signals are used to provide external pin diagnostic write (GPIO_12) and readback (GPIO_11) capability.

GPIO Port0 Control Register

Name:	GP0CON
Address:	0xFFFF0D00
Default Value:	0x11100000
Access:	Read/write
Function:	The 32-bit MMR selects the pin function for each Port0 pin.

Table 58. GP0CON MMR Bit Designations

Bit	Description
31 to 29	Reserved. These bits are reserved and should be written as 0 by user code.
28	Reserved. This bit is reserved and should be written as 1 by user code.
27 to 25	Reserved. These bits are reserved and should be written as 0 by user code.
24	Internal P0.6 Enable Bit. This bit must be set to 1 by user software to enable the high voltage serial interface before using the HVCON and HVDAT registered high voltage interface.
23 to 21	Reserved. These bits are reserved and should be written as 0 by user code.
20	Internal P0.5 Enable Bit. This bit must be set to 1 by user software to enable the high voltage serial interface before using the HVCON and HVDAT registered high voltage interface.
19 to 17	Reserved. These bits are reserved and should be written as 0 by user code.
16	GPIO_4 Function Select Bit. Cleared by user code to 0 to configure the GPIO_4 pin as a general-purpose I/O (GPIO) pin. Set to 1 by user code to configure the GPIO_4 pin as ECLK enabling a 2.56 MHz clock output on this pin.
15 to 13	Reserved. These bits are reserved and should be written as 0 by user code.
12	GPIO_3 Function Select Bit. Cleared by user code to 0 to configure the GPIO_3 pin as a general-purpose I/O (GPIO) pin. Set to 1 by user code to configure the GPIO_3 pin as MOSI, master output, and slave input data for the SPI port.
11 to 9	Reserved. These bits are reserved and should be written as 0 by user code.
8	GPIO_2 Function Select Bit. Cleared to 0 by user code to configure the GPIO_2 pin as a general-purpose I/O (GPIO) pin. Set to 1 by user code to configure the GPIO_2 pin as MISO, master input, and slave output data for the SPI port.
7 to 5	Reserved. These bits are reserved and should be written as 0 by user code.
4	GPIO_1 Function Select Bit. Cleared to 0 by user code to configure the GPIO_1 pin as a general-purpose I/O (GPIO) pin. Set to 1 by user code to configure the GPIO_1 pin as SCLK, serial clock I/O for the SPI port.
3 to 1	Reserved. These bits are reserved and should be written as 0 by user code.
0	GPIO_0 Function Select Bit. Cleared to 0 by user code to configure the GPIO_0 pin as a general-purpose I/O (GPIO) pin. Set to 1 by user code to configure the GPIO_0 pin as \overline{SS} , serial clock I/O for the SPI port.

GPIO Port1 Control Register

Name: GP1CON
Address: 0xFFFF0D04
Default Value: 0x10000000
Access: Read/write
Function: The 32-bit MMR selects the pin function for each Port1 pin.

Table 59. GP1CON MMR Bit Designations

Bit	Description
31 to 5	Reserved. These bits are reserved and should be written as 0 by user code.
4	GPIO_6 Function Select Bit. Cleared by user code to 0 to configure the GPIO_6 pin as a general-purpose I/O (GPIO) pin. Set to 1 by user code to configure the GPIO_6 pin as TxD, transmit data for UART serial port.
3 to 1	Reserved. These bits are reserved and should be written as 0 by user code.
0	GPIO_5 Function Select Bit. Cleared by user code to 0 to configure the GPIO_5 pin as a general-purpose I/O (GPIO) pin. Set by user code to 1 to configure the GPIO_5 RxD. Receive data for UART serial port.

GPIO Port2 Control Register

Name: GP2CON
Address: 0xFFFF0D08
Default Value: 0x01000000
Access: Read/write
Function: The 32-bit MMR selects the pin function for each Port2 pin.

Table 60. GP2CON MMR Bit Designations

Bit	Description
31 to 25	Reserved. These bits are reserved and should be written as 0 by user code.
24	GPIO_13 Function Select Bit. This bit is set to 1 by user code to route the STI data output to the STI pin. If this bit is cleared to 0 by user code, then the STI data is not be routed to the external STI pin even if the STI interface is enabled correctly.
23 to 21	Reserved. These bits are reserved and should be written as 0 by user code.
20	GPIO_12 Function Select Bit. This bit is cleared to 0 by user code to route the LIN/BSD transmit data to an internal general-purpose I/O (GPIO_12) pad which can then be written via the GP2DAT MMR. This configuration is used in BSD mode to allow user code to write output data to the BSD interface, and it can also be used to support diagnostic write capability to the high voltage I/O pins (see HVCFG1[2:0]). This bit is set to 1 by user code to route the UART TxD (transmit data) to the LIN/BSD data pin. This configuration is used in LIN mode.
19 to 17	Reserved. These bits are reserved and should be written as 0 by user code.
16	GPIO_11 Function Select Bit. This bit is cleared to 0 by user code to internally disable the LIN/BSD input data path. In this configuration GPIO_11 is used to support diagnostic readback on all external high voltage I/O pins (see HVCFG1[2:0]). This bit is set to 1 by user code to route input data from the LIN/BSD interface to both the LIN/BSD hardware timing/synchronization logic and to the UART RxD (receive data). This mode must be configured by user code when using LIN or BSD modes.
15 to 5	Reserved. These bits are reserved and should be written as 0 by user code.

Bit	Description
4	<p>GPIO_8 Function Select Bit.</p> <p>This bit is cleared by user code to 0 to configure the GPIO_8 pin as a general-purpose I/O (GPIO) pin.</p> <p>This bit is set by user code to 1 to route the LIN/BSD input data to the GPIO_8 pin. This mode can be used to drive the LIN transceiver interface as a standalone component without any interaction from MCU or UART.</p>
3 to 1	Reserved. These bits are reserved and should be written as 0 by user code.
0	<p>GPIO_7 Function Select Bit.</p> <p>This bit is cleared by user code to 0 to configure the GPIO_7 pin as a general-purpose I/O (GPIO) pin.</p> <p>This bit is set by user code to 1 to route data driven into the GPIO_7 pin through the on-chip LIN transceiver to be output at the LIN/BSD pin. This mode can be used to drive the LIN transceiver interface as a standalone component without any interaction from MCU or UART.</p>

GPIO Port0 Data Register

Name: GP0DAT

Address: 0xFFFF0D20

Default Value: 0x000000XX

Access: Read/write

Function: This 32-bit MMR configures the direction of the GPIO pins assigned to Port0 (see Table 57). This register also sets the output value for GPIO pins configured as outputs and reads the status of GPIO pins configured as inputs.

Table 61. GP0DAT MMR Bit Designations

Bit	Description
31 to 29	Reserved. These bits are reserved and should be written as 0 by user code.
28	Port 0.4 Direction Select Bit. This bit is cleared to 0 by user code to configure the GPIO pin assigned to Port 0.4 as an input. This bit is set to 1 by user code to configure the GPIO pin assigned to Port 0.4 as an output.
27	Port 0.3 Direction Select Bit. This bit is cleared to 0 by user code to configure the GPIO pin assigned to Port 0.3 as an input. This bit is set to 1 by user code to configure the GPIO pin assigned to Port 0.3 as an output.
26	Port 0.2 Direction Select Bit. This bit is cleared to 0 by user code to configure the GPIO pin assigned to Port 0.2 as an input. This bit is set to 1 by user code to configure the GPIO pin assigned to Port 0.2 as an output.
25	Port 0.1 Direction Select Bit. This bit is cleared to 0 by user code to configure the GPIO pin assigned to Port 0.1 as an input. This bit is set to 1 by user code to configure the GPIO pin assigned to Port 0.1 as an output.
24	Port 0.0 Direction Select Bit. This bit is cleared to 0 by user code to configure the GPIO pin assigned to Port 0.0 as an input. This bit is set to 1 by user code to configure the GPIO pin assigned to Port 0.0 as an output.
23 to 21	Reserved. These bits are reserved and should be written as 0 by user code.
20	Port 0.4 Data Output. The value written to this bit appears directly on the GPIO pin assigned to Port 0.4.
19	Port 0.3 Data Output. The value written to this bit appears directly on the GPIO pin assigned to Port 0.3.
18	Port 0.2 Data Output. The value written to this bit appears directly on the GPIO pin assigned to Port 0.2.
17	Port 0.1 Data Output. The value written to this bit appears directly on the GPIO pin assigned to Port 0.1.
16	Port 0.0 Data Output. The value written to this bit appears directly on the GPIO pin assigned to Port 0.0.
15 to 5	Reserved. These bits are reserved and should be written as 0 by user code.
4	Port 0.4 Data Input. This bit is a read only bit that reflects the current status of the GPIO pin assigned to Port 0.4. User code should write 0 to this bit.
3	Port 0.3 Data Input. This bit is a read only bit that reflects the current status of the GPIO pin assigned to Port 0.3. User code should write 0 to this bit.
2	Port 0.2 Data Input. This bit is a read only bit that reflects the current status of the GPIO pin assigned to Port 0.2. User code should write 0 to this bit.
1	Port 0.1 Data Input. This bit is a read only bit that reflects the current status of the GPIO pin assigned to Port 0.1. User code should write 0 to this bit.
0	Port 0.0 Data Input. This bit is a read only bit that reflects the current status of the GPIO pin assigned to Port 0.0. User code should write 0 to this bit.

GPIO Port1 Data Register**Name:** GP1DAT**Address:** 0xFFFF0D30**Default Value:** 0x000000XX**Access:** Read/write**Function:** This 32-bit MMR configures the direction of the GPIO pins assigned to Port1 (see Table 57). This register also sets the output value for GPIO pins configured as outputs and reads the status of GPIO pins configured as inputs.**Table 62. GP1DAT MMR Bit Designations**

Bit	Description
31 to 26	Reserved. These bits are reserved and should be written as 0 by user code.
25	Port 1.1 Direction Select Bit. This bit is cleared to 0 by user code to configure the GPIO pin assigned to Port 1.1 as an input. This bit is set to 1 by user code to configure the GPIO pin assigned to Port 1.1 as an output.
24	Port 1.0 Direction Select Bit. This bit is cleared to 0 by user code to configure the GPIO pin assigned to Port 1.0 as an input. This bit is set to 1 by user code to configure the GPIO pin assigned to Port 1.0 as an output.
23 to 18	Reserved. These bits are reserved and should be written as 0 by user code.
17	Port 1.1 Data Output. The value written to this bit appears directly on the GPIO pin assigned to Port 1.1.
16	Port 1.0 Data Output. The value written to this bit appears directly on the GPIO pin assigned to Port 1.0.
15 to 2	Reserved. These bits are reserved and should be written as 0 by user code.
1	Port 1.1 Data Input. This bit is a read only bit that reflects the current status of the GPIO pin assigned to Port 1.1. User code should write 0 to this bit.
0	Port 1.0 Data Input. This bit is a read only bit that reflects the current status of the GPIO pin assigned to Port 1.0. User code should write 0 to this bit.

GPIO Port2 Data Register

Name: GP2DAT

Address: 0xFFFF0D40

Default Value: 0x000000XX

Access: Read/write

Function: This 32-bit MMR configures the direction of the GPIO pins assigned to Port2 (see Table 57). This register also sets the output value for GPIO pins configured as outputs and reads the status of GPIO pins configured as inputs.

Table 63. GP2DAT MMR Bit Designations

Bit	Description
31	Reserved. This bit is reserved and should be written as 0 by user code.
30	Port 2.6 Direction Select Bit. This bit is cleared to 0 by user code to configure the GPIO pin assigned to Port 2.6 as an input. This bit is set to 1 by user code to configure the GPIO pin assigned to Port 2.6 as an output.
29	Port 2.5 Direction Select Bit. This bit is cleared to 0 by user code to configure the GPIO pin assigned to Port 2.5 as an input. This bit is set to 1 by user code to configure the GPIO pin assigned to Port 2.5 as an output. This configuration is used to support diagnostic write capability to the high voltage I/O pins.
28	Port 2.4 Direction Select Bit. This bit is cleared to 0 by user code to configure the GPIO pin assigned to Port 2.4 as an input. This configuration is used to support diagnostic readback capability from the high voltage I/O pins (see HVCFG1[2:0]). This bit is set to 1 by user code to configure the GPIO pin assigned to Port 2.4 as an output.
27 to 26	Reserved. These bits are reserved and should be written as 0 by user code.
25	Port 2.1 Direction Select Bit. This bit is cleared to 0 by user code to configure the GPIO pin assigned to Port 2.1 as an input. This bit is set to 1 by user code to configure the GPIO pin assigned to Port 2.1 as an output.
24	Port 2.0 Direction Select Bit. This bit is cleared to 0 by user code to configure the GPIO pin assigned to Port 2.0 as an input. This bit is set to 1 by user code to configure the GPIO pin assigned to Port 2.0 as an output.
23	Reserved. This bit is reserved and should be written as 0 by user code.
22	Port 2.6 Data Output. The value written to this bit appears directly on the GPIO pin assigned to Port 2.6.
21	Port 2.5 Data Output. The value written to this bit appears directly on the GPIO pin assigned to Port 2.5.
20 to 18	Reserved. These bits are reserved and should be written as 0 by user code.
17	Port 2.1 Data Output. The value written to this bit appears directly on the GPIO pin assigned to Port 2.1.
16	Port 2.0 Data Output. The value written to this bit appears directly on the GPIO pin assigned to Port 2.0.
15 to 7	Reserved. These bits are reserved and should be written as 0 by user code.
6	Port 2.6 Data Input. This bit is a read only bit that reflects the current status of the GPIO pin assigned to Port 2.6. User code should write 0 to this bit.
5	Port 2.5 Data Input. This bit is a read only bit that reflects the current status of the GPIO pin assigned to Port 2.5. User code should write 0 to this bit.
4	Port 2.4 Data Input. This bit is a read only bit that reflects the current status of the GPIO pin assigned to Port 2.4. User code should write 0 to this bit.
3 to 2	Reserved. These bits are reserved and should be written as 0 by user code.
1	Port 2.1 Data Input. This bit is a read only bit that reflects the current status of the GPIO pin assigned to Port 2.1. User code should write 0 to this bit.
0	Port 2.0 Data Input. This bit is a read only bit that reflects the current status of the GPIO pin assigned to Port 2.0. User code should write 0 to this bit.

GPIO Port0 Set Register**Name:** GP0SET**Address:** 0xFFFF0D24**Access:** Write only

Function: This 32-bit MMR allows user code to individually bit-address external GPIO pins to set them high only. User code can accomplish this using the GP0SET MMR without having to modify or maintain the status of any other GPIO pins (as user code requires when using GP0DAT).

Table 64. GP0SET MMR Bit Designations

Bit	Description
31 to 21	Reserved. These bits are reserved and should be written as 0 by user code.
20	Port 0.4 Set Bit. This bit is set to 1 by user code to set the external GPIO_4 pin high. If user software clears this bit to 0, it has no effect on the external GPIO_4 pin.
19	Port 0.3 Set Bit. This bit is set to 1 by user code to set the external GPIO_3 pin high. If user software clears this bit to 0, it has no effect on the external GPIO_3 pin.
18	Port 0.2 Set Bit. This bit is set to 1 by user code to set the external GPIO_2 pin high. If user software clears this bit to 0, it has no effect on the external GPIO_2 pin.
17	Port 0.1 Set Bit. This bit is set to 1 by user code to set the external GPIO_1 pin high. If user software clears this bit to 0, it has no effect on the external GPIO_1 pin.
16	Port 0.0 Set Bit. This bit is set to 1 by user code to set the external GPIO_0 pin high. If user software clears this bit to 0, it has no effect on the external GPIO_0 pin.
15 to 0	Reserved. These bits are reserved and should be written as 0 by user code.

GPIO Port1 Set Register**Name:** GP1SET**Address:** 0xFFFF0D34**Access:** Write only

Function: This 32-bit MMR allows user code to individually bit-address external GPIO pins to set them high only. User code can accomplish this using the GP1SET MMR without having to modify or maintain the status of any other GPIO pins (as user code requires when using GP1DAT).

Table 65. GP1SET MMR Bit Designations

Bit	Description
31 to 18	Reserved. These bits are reserved and should be written as 0 by user code.
17	Port 1.1 Set Bit. This bit is set to 1 by user code to set the external GPIO_6 pin high. If user software clears this bit to 0, it has no effect on the external GPIO_6 pin.
16	Port 1.0 Set Bit. This bit is set to 1 by user code to set the external GPIO_5 pin high. If user software clears this bit to 0, it has no effect on the external GPIO_5 pin.
15 to 0	Reserved. These bits are reserved and should be written as 0 by user code.

GPIO Port2 Set Register**Name:** GP2SET**Address:** 0xFFFF0D44**Access:** Write only

Function: This 32-bit MMR allows user code to individually bit-address external GPIO pins to set them high only. User code can accomplish this using the GP2SET MMR without having to modify or maintain the status of any other GPIO pins (as user code requires when using GP2DAT).

Table 66. GP2SET MMR Bit Designations

Bit	Description
31 to 23	Reserved. These bits are reserved and should be written as 0 by user code.
22	Port 2.6 Set Bit. This bit is set to 1 by user code to set the external GPIO_13 pin high. If user software clears this bit to 0, it has no effect on the external GPIO_13 pin.
21	Port 2.5 Set Bit. This bit is set to 1 by user code to set the external GPIO_12 pin high. If user software clears this bit to 0, it has no effect on the external GPIO_12 pin.
20 to 18	Reserved. These bits are reserved and should be written as 0 by user code.
17	Port 2.1 Set Bit. This bit is set to 1 by user code to set the external GPIO_8 pin high. If user software clears this bit to 0, it has no effect on the external GPIO_8 pin.
16	Port 2.0 Set Bit. This bit is set to 1 by user code to set the external GPIO_7 pin high. If user software clears this bit to 0, it has no effect on the external GPIO_7 pin.
15 to 0	Reserved. These bits are reserved and should be written as 0 by user code.

GPIO Port0 Clear Register**Name:** GP0CLR**Address:** 0xFFFF0D28**Access:** Write only

Function: This 32-bit MMR allows user code to individually bit address external GPIO pins to clear them low only. User code can accomplish this using the GP0CLR MMR without having to modify or maintain the status of any other GPIO pins (as user code requires when using GP0DAT).

Table 67. GP0CLR MMR Bit Designations

Bit	Description
31 to 21	Reserved. These bits are reserved and should be written as 0 by user code.
20	Port 0.4 Clear Bit. This bit is set to 1 by user code to clear the external GPIO_4 pin low. If user software clears this bit to 0, it has no effect on the external GPIO_4 pin.
19	Port 0.3 Clear Bit. This bit is set to 1 by user code to clear the external GPIO_3 pin low. If user software clears this bit to 0, it has no effect on the external GPIO_3 pin.
18	Port 0.2 Clear Bit. This bit is set to 1 by user code to clear the external GPIO_2 pin low. If user software clears this bit to 0, it has no effect on the external GPIO_2 pin.
17	Port 0.1 Clear Bit. This bit is set to 1 by user code to clear the external GPIO_1 pin low. If user software clears this bit to 0, it has no effect on the external GPIO_1 pin.

Bit	Description
16	Port 0.0 Clear Bit. This bit is set to 1 by user code to clear the external GPIO_0 pin low. If user software clears this bit to 0, it has no effect on the external GPIO_0 pin.
15 to 0	Reserved. These bits are reserved and should be written as 0 by user code.

GPIO Port1 Clear Register**Name:** GP1CLR**Address:** 0xFFFF0D38**Access:** Write only

Function: This 32-bit MMR allows user code to individually bit-address external GPIO pins to clear them low only. User code can accomplish this using the GP1CLR MMR without having to modify or maintain the status of any other GPIO pins (as user code requires when using GP1DAT).

Table 68. GP1CLR MMR Bit Designations

Bit	Description
31 to 18	Reserved. These bits are reserved and should be written as 0 by user code.
17	Port 1.1 Clear Bit. This bit is set to 1 by user code to clear the external GPIO_6 pin low. If user software clears this bit to 0, it has no effect on the external GPIO_6 pin.
16	Port 1.0 Clear Bit. This bit is set to 1 by user code to clear the external GPIO_5 pin low. If user software clears this bit to 0, it has no effect on the external GPIO_5 pin.
15 to 0	Reserved. These bits are reserved and should be written as 0 by user code.

GPIO Port2 Clear Register**Name:** GP2CLR**Address:** 0xFFFF0D48**Access:** Write only

Function: This 32-bit MMR allows user code to individually bit-address external GPIO pins to clear them low only. User code can accomplish this using the GP2CLR MMR without having to modify or maintain the status of any other GPIO pins (as user code requires when using GP2DAT).

Table 69. GP2CLR MMR Bit Designations

Bit	Description
31 to 23	Reserved. These bits are reserved and should be written as 0 by user code.
22	Port 2.6 Clear Bit. This bit is set to 1 by user code to clear the external GPIO_13 pin low. If user software clears this bit to 0, it has no effect on the external GPIO_8 pin.
21	Port 2.5 Clear Bit. This bit is set to 1 by user code to clear the external GPIO_12 pin low. If user software clears this bit to 0, it has no effect on the external GPIO_7 pin.
20 to 18	Reserved. These bits are reserved and should be written as 0 by user code.
17	Port 2.1 Clear Bit. This bit is set to 1 by user code to clear the external GPIO_8 pin low. If user software clears this bit to 0, it has no effect on the external GPIO_8 pin.
16	Port 2.0 Clear Bit. This bit is set to 1 by user code to clear the external GPIO_7 pin low. If user software clears this bit to 0, it has no effect on the external GPIO_7 pin.
15 to 0	Reserved. These bits are reserved and should be written as 0 by user code.

HIGH VOLTAGE PERIPHERAL CONTROL INTERFACE

The ADuC7034 integrates a number of high voltage circuit functions that are controlled and monitored through a registered interface consisting of two MMRs, namely, HVCON and HVDAT. The HVCON register acts as a command byte interpreter allowing the microcontroller to indirectly read or write 8-bit data (the value in HVDAT) from or to one of four high voltage status or configuration registers. These high voltage registers are not MMRs but registers commonly referred to as indirect registers, that is, they can only be accessed (as the name suggests) indirectly via the HVCON and HVDAT MMRs.

The physical interface between the HVCON register and the indirect high voltage registers is a 2-wire (data and clock) serial interface based on a 2.56 MHz serial clock. Therefore, there is a finite, 10 μs (maximum) latency between the MCU core writing a command into HVCON and that command or data reaching the indirect high voltage registers. There is also a finite 10 μs latency between the MCU core writing a command into HVCON

and indirect register data being read back into the HVDAT register. A busy bit (Bit 0 of the HVCON when read by MCU) can be polled by the MCU to confirm when a read/write command is complete.

The following high voltage circuit functions are controlled and monitored via this interface and Figure 38 shows the top level architecture of the high voltage interface and related circuits:

- Precision oscillator
- Wake-up (WU) pin functionality
- Power supply monitor (PSM)
- Low voltage flag (LVF)
- LIN operating modes
- STI diagnostics
- High voltage diagnostics
- High voltage attenuator buffers circuit
- High voltage (HV) temperature monitor

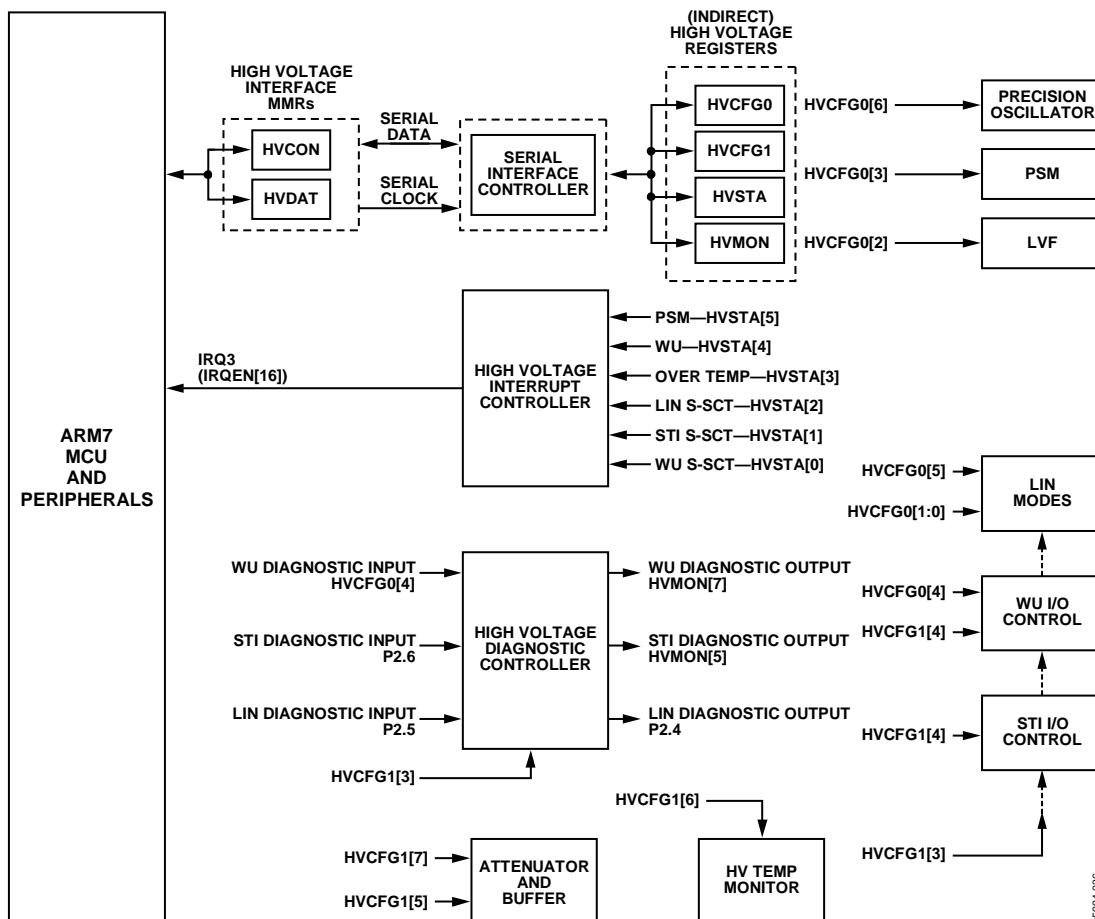

Figure 38. High Voltage Interface, Top Level Block Diagram

High Voltage Interface Control Register**Name:** HVCON**Address:** 0xFFFF0804**Default Value:** Updated by kernel**Access:** Read/write

Function: This 8-bit register acts as a command byte interpreter for the high voltage control interface. Bytes written to this register are interpreted as read or write commands to a set of four indirect registers related to the high voltage circuits. The HVDAT register is used to store data to be written to, or read back from, the indirect registers.

Table 70. HVCON MMR Write Bit Designations

Bit	Description
7 to 0	Command Byte. Interpreted as 0x00 = read back High Voltage Register HVCFG0 into HVDAT. 0x01 = read back High Voltage Register HVCFG1 into HVDAT. 0x02 = read back High Voltage Status Register HVSTA into HVDAT. 0x03 = read back High Voltage Status Register HVMON into HVDAT. 0x08 = write the value in HVDAT to the High Voltage Register HVCFG0. 0x09 = write the value in HVDAT to the High Voltage Register HVCFG1.

Table 71. HVCON MMR Read Bit Designations

Bit	Description
7 to 3	Reserved.
2	Transmit Command to High Voltage Die Status. 1 = command completed successfully. 0 = command failed.
1	Read Command from High Voltage Die Status. 1 = command completed successfully. 0 = command failed.
0	Bit 0 (Read Only) Busy Bit. When user code reads this register, Bit 0 should be interpreted as the busy signal for the high voltage interface. This bit can be used to determine if a read request has completed. High voltage (read/write) commands as described in this table should not be written to HVCON unless busy = 0. Busy = 1, high voltage interface is busy and has not completed the previous command written to HVCON. Bit 1 and Bit 2 are not valid. Busy = 0, high voltage interface is not busy and has completed the command written to HVCON. Bit 1 and Bit 2 are valid.

High Voltage Data Register

Name: HVDAT

Address: 0xFFFF080C

Default Value: Updated by kernel

Access: Read/write

Function: HVDAT is a 12-bit register that is used to hold data to be written indirectly to, and read indirectly from, the following high voltage interface registers.

Table 72. HVDAT MMR Bit Designations

Bit	Description
11 to 8	Command with which High Voltage Data HVDAT[7:0] is associated. These bits are read only and should be written as zeros. 0x00 = read back High Voltage Register HVCFG0 into HVDAT. 0x01 = read back High Voltage Register HVCFG1 into HVDAT. 0x02 = read back High Voltage Status Register HVSTA into HVDAT. 0x03 = read back High Voltage Status Register HVMON into HVDAT. 0x08 = write the value in HVDAT to the High Voltage Register HVCFG0. 0x09 = write the value in HVDAT to the High Voltage Register HVCFG1.
7 to 0	High Voltage Data to Read/Write.

High Voltage Configuration0 Register**Name:** HVCFG0**Address:** Indirectly addressed via the HVCON high voltage interface**Default Value:** 0x00**Access:** Read/write**Function:** This 8-bit register controls the function of high voltage circuits on the ADuC7034. This register is not an MMR and does not appear in the MMR memory map. It is accessed via the HVCON registered interface. Data to be written to this register is loaded via the HVDAT MMR, and data is read back from this register via the HVDAT MMR.**Table 73. HVCFG0 Bit Designations**

Bit	Description
7	Wake/STI Thermal Shutdown Disable. This bit is set to 1 to disable the automatic shutdown of the wake/STI driver when a thermal event occurs. This bit is cleared to 0 to enable the automatic shutdown of the wake/STI driver when a thermal event occurs.
6	Precision Oscillator Enable Bit. This bit is set to 1 to enable the precision, 131 kHz oscillator. The oscillator start-up time is typically 70 μ s (including high voltage interface latency of 10 μ s). This bit is cleared to 0 to power down the precision, 131 kHz oscillator.
5	Bit Serial Device (BSD) Mode Enable Bit. This bit is cleared to 0 to enable an internal (LIN) pull-up resistor on the LIN/BSD pin. This bit is set to 1 to disable the internal (LIN) pull-up and configure the LIN/BSD pin for BSD operation.
4	Wake Up (WU) Assert Bit. This bit is set to 1 to assert the external WU pin high. This bit is cleared to 0 to pull the external WU pin low via an internal 10 k Ω pull-down resistor.
3	Power Supply Monitor (PSM) Enable Bit. This bit is cleared to 0 to disable the power supply (voltage at the VDD pin) monitor. This bit is set to 1 to enable the power supply (voltage at the VDD pin) monitor. If IRQ3 (IRQEN[16] is enabled the PSM generates an interrupt if the voltage at the VDD pin drops below 6.0 V.
2	Low Voltage Flag (LVF) Enable Bit. This bit is cleared to 0 to disable the LVF function. This bit is set to 1 to enable the LVF function. The low voltage flag can be interrogated via HVMON[3] after power up to determine if the REG_DVDD voltage previously dropped below 2.1 V.
1 to 0	LIN Operating Mode. These bits enable/disable the LIN driver. 00 = LIN disabled. 01 = reserved (not LIN V2.0 compliant). 10 = LIN enabled. 11 = reserved, not used.

High Voltage Configuration1 Register**Name:** HVCFG1**Address:** Indirectly addressed via the HVCON high voltage interface**Default Value:** 0x00**Access:** Read/write**Function:** This 8-bit register controls the function of high voltage circuits on the ADuC7034. This register is not an MMR and does not appear in the MMR memory map. It is accessed via the HVCON registered interface; data to be written to this register is loaded through HVDAT and data is read back from this register using HVDAT.**Table 74. HVCFG1 Bit Designations**

Bit	Description
7	Voltage Attenuator Diagnostic Enable Bit. This bit is cleared to 0 to disable the voltage attenuator diagnostic. This bit is set to 1 to turn on a 1.29 μ A current source which adds 170mV differential voltage to the voltage channel measurement.
6	High Voltage Temperature Monitor. The high voltage temperature monitor is an uncalibrated temperature monitor located on-chip close to the high voltage circuits. This monitor is completely separate to the on-chip, precision temperature sensor (controlled via ADC1CON[7:6]) and allows user code to monitor die temperature change close to the hottest part of the ADuC7034 die. The monitor generates a typical output voltage of 600 mV at 25°C and has a negative temperature coefficient of typically -2.1 mV/°C. This bit is set to 1 to enable the on-chip, high voltage temperature monitor. When enabled, this voltage output temperature monitor is routed directly to the voltage channel ADC. This bit is cleared to 0 to disable the on-chip, high voltage temperature monitor.
5	Voltage Channel Short Enable Bit. This bit is set to 1 to enable an internal short (at the attenuator, before the ADC input buffers) on the voltage channel ADC and allows noise be measured as a self-diagnostic test. This bit is cleared to 0 to disable an internal short on the voltage channel.
4	WU and STI Read Back Enable Bit. This bit is cleared to 0 to disable input capability on the external WU/STI pins. This bit is set to 1 to enable input capability on the external WU/STI pins. In this mode, a rising or falling edge transition on the WU/STI pins generates a high voltage interrupt. When this bit is set, the state of the WU/STI pins can be monitored via the HVMON register (HVMON[7] and HVMON[5]).
3	High Voltage I/O Driver Enable Bit. This bit is set to 1 to re-enable any high voltage I/O pins (LIN/BSD, STI, and WU) that have been disabled as a result of a short-circuit current event (the event must last longer than 20 μ s for LIN/BSD and STI pins and 400 μ s for the WU pin). This bit must also be set to 1 to re-enable the WU and STI pins if they were disabled by a thermal event. It should be noted that this bit must be set to clear any pending interrupt generated by the short-circuit event (even if the event has passed) as well as re-enabling the high voltage I/O pins. This bit is cleared to 0 automatically.
2	Enable/Disable Short-Circuit Protection (LIN/BSD and STI). This bit is set to 1 to enable passive short-circuit protection on the LIN pin. In this mode, a short-circuit event on the LIN/BSD pin generates a high voltage interrupt, IRQ3 (if enabled in IRQEN[16]), and asserts the appropriate status bit in HVSTA but does not disable the short-circuiting pin. This bit is cleared to 0 to enable active short-circuit protection on the LIN/BSD pin. In this mode, during a short-circuit event, the LIN/BSD pin generates a high voltage interrupt (IRQ3), asserts HVSTA[16], and automatically disables the short-circuiting pin. When disabled, the I/O pin can only be re-enabled by writing to HVCFG1[3].
1	WU Pin Timeout (Monoflop) Counter Enable/Disable. This bit is set to disable the WU I/O timeout counter. This bit is cleared to enable a timeout counter that automatically deasserts the WU pin 1.3 seconds after user code has asserted the WU pin via HVCFG0[4].
0	WU Open-Circuit Diagnostic Enable. This bit is set to enable an internal WU I/O diagnostic pull-up resistor to the VDD pin thus allowing detection of an open-circuit condition on the WU pin. This bit is cleared to disable an internal WU I/O diagnostic pull-up resistor.

High Voltage Monitor Register**Name:** HVMON**Address:** Indirectly addressed via the HVCON high voltage interface**Default Value:** 0x00**Access:** Read only**Function:** This 8-bit, read only register reflects the current status of enabled high voltage related circuits and functions on the ADuC7034. This register is not an MMR and does not appear in the MMR memory map. It is accessed via the HVCON registered interface, and data is read back from this register via HVDAT.**Table 75. HVMON Bit Designations**

Bit	Description
7	WU Pin Diagnostic Readback. When enabled via HVCFG1[4], this read only bit reflects the state of the external WU pin.
6	Overtemperature. This bit is 0 if a thermal shutdown event has not occurred. This bit is 1 if a thermal shutdown event has occurred.
5	STI Pin Diagnostic Readback. When enabled via HVCFG1[4], this read only bit reflects the state of the external STI pin.
4	Buffer Enabled. This bit is 0 if the Voltage Channel ADC input buffer is disabled. This bit is 1 if the Voltage Channel ADC input buffer is enabled.
3	Low Voltage Flag Status Bit. Valid only if enabled via HVCFG0[2]. This bit is 0 on power-on if REG_DVDD has dropped below 2.1 V. In this state, RAM contents can be deemed corrupt. This bit is 1 on power-on if REG_DVDD has not dropped below 2.1 V. In this state, RAM contents can be deemed valid. It is only cleared by re-enabling the low voltage flag in HVCFG0[2].
2	LIN/BSD Short-Circuit Status Flag. This bit is 0 if the LIN/BSD driver is operating normally. This bit is 1 if the LIN/BSD driver has experienced a short-circuit condition and is cleared automatically by writing to HVCFG1[3].
1	STI Short-Circuit Status Flag. This bit is 0 if the STI driver is operating normally. This bit is 1 if the STI driver has experienced a short-circuit condition and is cleared automatically by writing to HVCFG1[3].
0	Wake Short-Circuit Status Flag. This bit is 0 if the wake driver is operating normally. This bit is 1 if the wake driver has experienced a short-circuit condition.

High Voltage Status Register**Name:** HVSTA**Address:** Indirectly addressed via the HVCON high voltage interface**Default Value:** 0x00**Access:** Read only, this register should only be read on a high voltage interrupt**Function:** This 8-bit, read only register reflects a change of state for all the corresponding bits in the HVMON register. This register is not an MMR and does not appear in the MMR memory map. It is accessed through the HVCON registered interface and data is read back from this register via HVDAT. In response to a high voltage interrupt event, the high voltage interrupt controller simultaneously and automatically loads the current value of the high voltage status register (HVSTA) into the HVDAT register.**Table 76. HVSTA Bit Designations**

Bit	Description
7 to 6	Reserved. These bits should not be used and are reserved for future use.
5	PSM Status Bit (Only Valid If Enabled via HVCFG0[3]). This bit is not latched and the IRQ needs to be enabled to detect it. This bit is 0 if the voltage at the VDD pin stays above 6.0 V. This bit is 1 if the voltage at the VDD pin drops below 6.0 V.
4	WU Request Status Bit. Valid only if enabled via HVCFG1[4]. When enabled via HVCFG1[4], this bit is set to 1 to indicate that a rising or falling edge transition on the WU pin generated a high voltage interrupt.
3	Overtemperature. This bit is always enabled. This bit is 0 if a thermal shutdown event has not occurred. This bit is 1 if a thermal shutdown event has occurred. All high voltage (LIN/BSD, WU, and STI) pin drivers are automatically disabled once a thermal shutdown has occurred.
2	LIN/BSD Short-Circuit Status Flag. This bit is 0 during normal LIN/BSD operation and is cleared automatically by reading the HVSTA register. This bit is 1 if a LIN/BSD short circuit is detected. In this condition, the LIN driver is automatically disabled.
1	STI Short-Circuit Status Flag. This bit is 0 if the STI driver is operating normally and is cleared automatically by reading the HVSTA register. This bit is 1 if the STI driver has experienced a short-circuit condition.
0	Wake Short-Circuit Status Flag. This bit is 0 during normal wake operation. This bit is 1 if a wake short-circuit is detected.

WAKE UP (WU)

The wake-up (WU) pin is a high voltage GPIO controlled through HVCON and HVDAT.

Wake-Up (WU) Pin Circuit Description

The WU pin is configured by default as an output with an internal 10 kΩ pull-down resistor and high-side FET driver. The WU pin, in its default mode of operation, is specified to generate an active high system wake-up request by forcing the external system WU bus high. User code can assert the WU output by writing directly to HVCFG0[4].

Note that the output only responds after the 10 μs latency through the (serial communication based) high voltage interface.

The internal FET is capable of sourcing significant current and, therefore, substantial on-chip self-heating can occur if this driver is asserted for a long time period. For this reason, a

monoflop, a 1.3-second timeout timer, is included. By default, the monoflop is enabled and disables the wake-up driver after 1.3 seconds. It is possible to disable the monoflop through HVCFG1[1]. If the wake-up monoflop is disabled, then the wake-up driver should be disabled after 1.3 seconds.

The WU pin also features a short-circuit detection feature. When the wake-up pin sources more than 100 mA typically for 400 μs, a high voltage interrupt is generated with HVMON[0] set.

A thermal shutdown event disables the WU driver. The WU driver must be re-enabled manually after a thermal event using HVCFG1[3].

The WU pin can be configured in I/O mode by writing a 1 to HVCFG1[4]. In this mode, a rising or falling edge immediately generates a high voltage interrupt. HVMON[7] directly reflects the state of the external WU pin. This comparator has a trip level of 3 V_{TYP}.

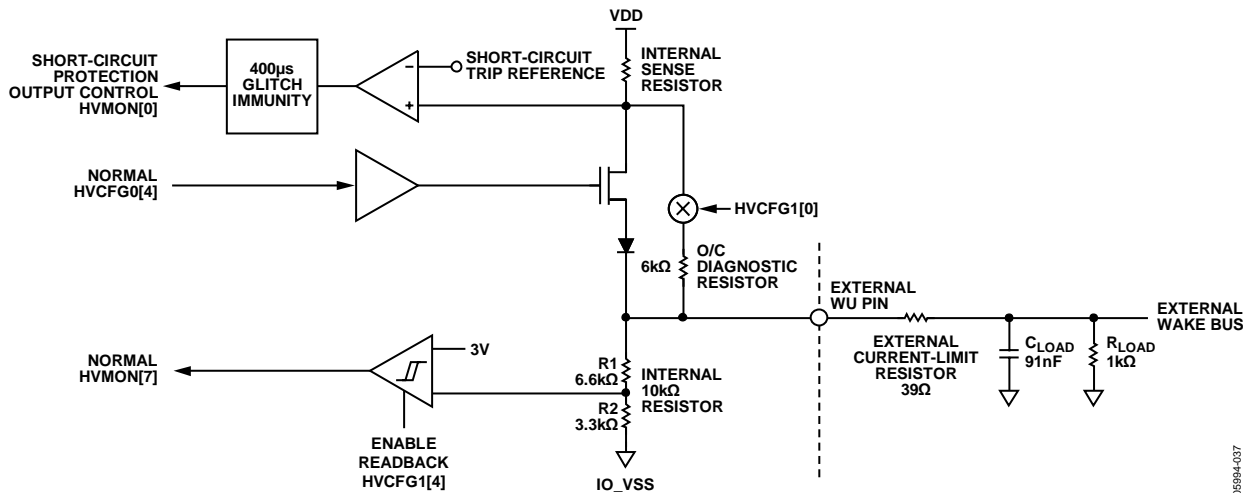

Figure 39. WU Circuit, Block Diagram

05994-037

HANDLING INTERRUPTS FROM THE HIGH VOLTAGE PERIPHERAL CONTROL INTERFACE

An interrupt controller is also integrated with the high voltage circuits. If enabled through IRQEN[16], one of six high voltage sources can assert the high voltage interrupt (IRQ3) signal and interrupt the MCU core.

Although the normal MCU response to this interrupt event is to vector to the IRQ or FIQ interrupt vector address, the high voltage interrupt controller simultaneously and automatically loads the current value of the high voltage status register (HVSTA) into the HVDAT register. During this time, the busy bit in HVCON[0] is set to indicate the transfer is in progress and clears after 10 μs to indicate the HVSTA contents are available in HVDAT.

The interrupt handler can, therefore, poll the busy bit in HVCON until it deasserts. Once the busy bit is cleared, HVCON[1] must be checked to ensure the data was read

correctly. Then the HVDAT register can be read. At this time, HVDAT holds the value of the HVSTA register. The status flags can then be interrogated to determine the exact source of the high voltage interrupt and the appropriate action can be taken.

LOW VOLTAGE FLAG (LVF)

The ADuC7034 features a low voltage flag (LVF), that when enabled, allows the user to monitor REG_DVDD. When enabled via HVCFG0[2], the low voltage flag can be monitored through HVMON[3]. If REG_DVDD drops below 2.1 V, then HVMON[3] is cleared and the RAM contents are corrupted. After the low voltage flag is enabled, it is only reset by REG_DVDD dropping below 2.1 V or by disabling the LVF functionality using HVCFG0[2].

HIGH VOLTAGE DIAGNOSTICS

It is possible to diagnosis fault conditions on the wake, LIN, and STI bus as listed in Table 77.

Table 77. High Voltage Diagnostics

High Voltage Pin	Fault Condition	Method	Result
LIN/STI	Short between LIN/STI and VBAT	Drive LIN low	LIN/STI short-circuit interrupt is generated after 20 μs if more than 100 mA is continuously drawn.
	Short between LIN/STI and GND	Drive LIN high	LIN/STI readback reads back low.
Wake Up	Short between wake up and VBAT	Drive Wake Up low	Readback high in HVMON[7].
	Short between wake up and GND	Drive Wake Up high	Wake short-circuit interrupt is generated after 400 μs if more than 100 mA typically is sourced.
	Open circuit	Enable OC diagnostic resistor with wake up disabled	HVMON[7] is cleared if the load is connected and set if wake is open-circuited.

UART SERIAL INTERFACE

The ADuC7034 features a 16,450-compatible UART. The UART is a full-duplex, universal, asynchronous receiver/transmitter. A UART performs serial-to-parallel conversion on data characters received from a peripheral device, and parallel-to-serial conversion on data characters received from the ARM7TDMI. The UART features a fractional divider that facilitates high accuracy baud rate generation and a network addressable mode. The UART functionality is available on the GPIO_5/RxD and GPIO_6/TxD pins of the ADuC7034.

The serial communication adopts an asynchronous protocol that supports various word length, stop bits, and parity generation options selectable in the configuration register.

BAUD RATE GENERATION

The ADuC7034 features two methods of generating the UART baud rate: normal 450 UART baud rate generation and ADuC7034 fractional divider.

Normal 450 UART Baud Rate Generation

The baud rate is a divided version of the core clock using the value in COMDIV0 and COMDIV1 MMRs (16-bit value, DL). The standard baud rate generator formula is

$$Baud\ rate = \frac{20.48\ MHz}{2^{CD} \times 16 \times 2 \times DL} \tag{1}$$

Table 78 lists common baud rate values.

Table 78. Baud Rate Using the Standard Baud Rate Generator

Baud Rate	CD	DL	Actual Baud Rate	% Error
9600	0	0x43	9552	0.50%
19,200	0	0x21	19,394	1.01%
115,200	0	0x6	106,667	7.41%
9600	3	0x8	10,000	4.17%
19,200	3	0x4	20,000	4.17%
115,200	3	0x1	80,000	30.56%

ADuC7034 Fractional Divider

The fractional divider combined with the normal baud rate generator allows the generation of accurate, high speed baud rates.

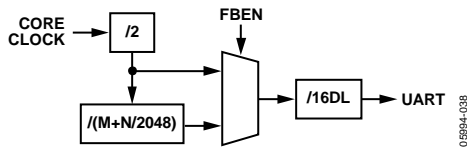

Figure 40. Fractional Divider Baud Rate Generation

Calculation of the baud rate using a fractional divider is as follows:

$$Baud\ rate = \frac{20.48MHz}{2^{CD} \times 16 \times DL \times 2 \times (M + \frac{N}{2048})} \tag{2}$$

$$M + \frac{N}{2048} = \frac{20.48MHz}{Baud\ rate \times 2^{CD} \times 16 \times DL \times 2}$$

Table 79 lists common baud rate values.

Table 79. Baud Rate Using the Fractional Baud Rate Generator

Baud Rate	CD	DL	M	N	Actual Baud Rate	% Error
9600	0	0x42	1	21	9598.55	0.015%
19,200	0	0x21	1	21	19,197.09	0.015%
115,200	0	0x5	1	228	115,177.51	0.0195%

UART REGISTER DEFINITION

The UART interface consists of the following nine registers:

- COMTX: 8-bit transmit register
- COMRX: 8-bit receive register
- COMDIV0: divisor latch (low byte)
- COMDIV1: divisor latch (high byte)
- COMCON0: line control register
- COMSTA0: line status register
- COMIEN0: interrupt enable register
- COMIID0: interrupt identification register
- COMDIV2: 16-bit fractional baud divide register

COMTX, COMRX, and COMDIV0 share the same address location. COMTX and COMRX can be accessed when Bit 7 in the COMCON0 register is cleared. COMDIV0 can be accessed when Bit 7 of COMCON0 is set.

UART TX Register

Name: COMTX
Address: 0xFFFF0700
Access: Write only
Function: Write to this 8-bit register to transmit data using the UART.

UART RX Register

Name: COMRX
Address: 0xFFFF0700
Default Value: 0x00
Access: Read only
Function: This 8-bit register is read from to receive data transmitted using the UART.

UART Divisor Latch Register 0

Name: COMDIV0
Address: 0xFFFF0700
Default Value: 0x00
Access: Read/write
Function: This 8-bit register contains the least significant byte of the divisor latch that controls the baud rate at which the UART operates.

UART Divisor Latch Register 1

Name: COMDIV1
Address: 0xFFFF0704
Default Value: 0x00
Access: Read/write
Function: This 8-bit register contains the most significant byte of the divisor latch that controls the baud rate at which the UART operates.

UART Control Register 0

Name: COMCON0

Address: 0xFFFF070C

Default Value: 0x00

Access: Read/write

Function: This 8-bit register controls the operation of the UART in conjunction with COMCON1.

Table 80. COMCON0 MMR Bit Designations

Bit	Name	Description
7	DLAB	Divisor Latch Access. Set by user to enable access to COMDIV0 and COMDIV1 registers. Cleared by user to disable access to COMDIV0 and COMDIV1 and enable access to COMRX, COMTX, and COMIEN0.
6	BRK	Set Break. Set by user to force TxD to 0. Cleared to operate in normal mode.
5	SP	Stick Parity. Set by user to force parity to defined values. 1 if EPS = 1 and PEN = 1. 0 if EPS = 0 and PEN = 1.
4	EPS	Even Parity Select Bit. Set for even parity. Cleared for odd parity.
3	PEN	Parity Enable Bit. Set by user to transmit and check the parity bit. Cleared by user for no parity transmission or checking.
2	STOP	Stop Bit. Set by the user to transmit 1.5 stop bits if the word length is 5 bits, or 2 stop bits if the word length is 6, 7, or 8 bits. The receiver checks the first stop bit only, regardless of the number of stop bits selected. Cleared by the user to generate one stop bit in the transmitted data.
1 to 0	WLS	Word Length Select. 00 = 5 bits. 01 = 6 bits. 10 = 7 bits. 11 = 8 bits.

UART Control Register 1

Name: COMCON1

Address: 0xFFFF0710

Default Value: 0x00

Access: Read/write

Function: This 8-bit register controls the operation of the UART in conjunction with COMCON0.

Table 81. COMCON1 MMR Bit Designations

Bit	Name	Description
7 to 6		UART Input Mux. 00 = RxD driven by LIN input; required for LIN communications using the LIN pin. 01 = reserved. 10 = RxD driven by GP5; required for serial communications using GPIO_5 pin (RxD). 11 = reserved.
5		Reserved. Not used.
4	LOOPBACK	Loopback. Set by user to enable loopback mode. In loopback mode, the TxD is forced high.
3 to 0		Reserved. Not used.

UART Status Register 0

Name: COMSTA0

Address: 0xFFFF0714

Default Value: 0x60

Access: Read only

Function: This 8-bit read only register reflects the current status on the UART.

Table 82. COMSTA0 MMR Bit Designations

Bit	Name	Description
7		Reserved.
6	TEMT	COMTX and Shift Register Empty Status Bit. Set automatically if COMTX and the shift register are empty. This bit indicates that the data has been transmitted, that is, no more is present in the shift register. Cleared automatically when writing to COMTX.
5	THRE	COMTX Empty Status Bit. Set automatically if COMTX is empty. COMTX can be written as soon as this bit is set, the previous data might not have been transmitted yet and can still be present in the shift register. Cleared automatically when writing to COMTX.
4	BI	Break Indicator. Set when SIN is held low for more than the maximum word length. Cleared automatically.
3	FE	Framing Error. Set when the stop bit is invalid. Cleared automatically.
2	PE	Parity Error. Set when a parity error occurs. Cleared automatically.
1	OE	Overrun Error. Set automatically if data are overwritten before being read. Cleared automatically.
0	DR	Data Ready. Set automatically when COMRX is full. Cleared by reading COMRX.

UART Interrupt Enable Register 0**Name:** COMIEN0**Address:** 0xFFFF0704**Default Value:** 0x00**Access:** Read/write**Function:** The 8-bit register enables and disables the individual UART interrupt sources.**Table 83. COMIEN0 MMR Bit Designations**

Bit	Name	Description
7 to 4		Reserved. Not used.
3	EDSSI	Reserved. This bit should be written as 0.
2	ELSI	RxD Status Interrupt Enable Bit. Set by the user to enable generation of an interrupt if any of the COMSTA0[3:1] register bits are set. Cleared by the user.
1	ETBEI	Enable Transmit Buffer Empty Interrupt. Set by the user to enable an interrupt when the buffer is empty during a transmission, that is, when COMSTA[5] is set. Cleared by the user.
0	ERBFI	Enable Receive Buffer Full Interrupt. Set by the user to enable an interrupt when the buffer is full during a reception. Cleared by the user.

UART Interrupt Identification Register 0**Name:** COMIID0**Address:** 0xFFFF0708**Default Value:** 0x01**Access:** Read only**Function:** This 8-bit register reflects the source of the UART interrupt.**Table 84. COMIID0 MMR Bit Designations**

Bits[2:1] Status Bits	Bit 0 NINT	Priority	Definition	Clearing Operation
00	1		No interrupt	
11	0	1	Receive line status interrupt	Read COMSTA0
10	0	2	Receive buffer full interrupt	Read COMRX
01	0	3	Transmit buffer empty interrupt	Write data to COMTX or read COMIID0
00	0	4	Modem status interrupt	Read COMSTA1 register

UART Fractional Divider Register**Name:** COMDIV2**Address:** 0xFFFF072C**Default Value:** 0x0000**Access:** Read/write**Function:** This 16-bit register controls the operation of the fractional divider for the ADuC7034.**Table 85. COMDIV2 MMR Bit Designations**

Bit	Name	Description
15	FBEN	Fractional Baud Rate Generator Enable Bit. Set by the user to enable the fractional baud rate generator. Cleared by the user to generate the baud rate using the standard 450 UART baud rate generator.
14 to 13		Reserved.
12 to 11	FBM[1:0]	M. If FBM = 0, M = 4. See Equation 2 for the calculation of the baud rate using a fractional divider and Table 79 for common baud rate values.
10 to 0	FBN[10:0]	N. See Equation 2 for the calculation of the baud rate using a fractional divider and Table 79 for common baud rate values.

SERIAL PERIPHERAL INTERFACE

The ADuC7034 features a complete hardware serial peripheral interface (SPI) on-chip. SPI is an industry standard synchronous serial interface that allows eight bits of data to be synchronously transmitted and received simultaneously, that is, full duplex.

The SPI interface is only operational with core clock divider bits (POWCON[2:0] = 0 or 1).

The SPI port can be configured for master or slave operation and consists of four pins that are multiplexed with four GPIOs. The four SPI pins are MISO, MOSI, SCLK, and \overline{SS} . The pins to which these signals are connected are shown in Table 86.

Table 86. SPI Output Pins

Pin	Signal	Description
GP0 (GPIO MODE 1)	\overline{SS}	Chip select
GP1 (GPIO MODE 1)	SCLK	Serial clock
GP2 (GPIO MODE 1)	MISO	Master out, slave in
GP3 (GPIO MODE 1)	MOSI	Master in, slave out

MISO (MASTER IN, SLAVE OUT DATA I/O PIN)

The master in slave out (MISO) pin is configured as an input line in master mode and an output line in slave mode. The MISO line on the master (data in) should be connected to the MISO line in the slave device (data out). The data is transferred as byte wide (8-bit) serial data, MSB first.

MOSI (MASTER OUT, SLAVE IN PIN)

The MOSI (master out slave in) pin is configured as an output line in master mode and an input line in slave mode. The MOSI line on the master (data out) should be connected to the MOSI line in the slave device (data in). The data is transferred as byte wide (8-bit) serial data, MSB first.

SCLK (SERIAL CLOCK I/O PIN)

The master serial clock (SCLK) is used to synchronize the data being transmitted and received through the MOSI SCLK period. Therefore, a byte is transmitted/received after eight SCLK periods. The SCLK pin is configured as an output in master mode and as an input in slave mode.

In master mode, polarity and phase of the clock is controlled by the SPICON register, and the bit rate is defined in the SPIDIV register using the SPI baud rate calculation, as follows:

$$f_{SERIALCLOCK} = \frac{20.48\text{MHz}}{2 \times (1 + SPIDIV)} \quad (3)$$

The maximum speed of the SPI clock is dependent on the clock divider bits and is summarized in Table 87.

Table 87. SPI Speed vs. Clock Divider Bits in Master Mode

CD Bits	0	1
SPIDIV	0x05	0x0B
Maximum SCLK	1.667 MHz	0.833 MHz

In slave mode, the SPICON register must be configured with the phase and polarity of the expected input clock. The slave accepts data from an external master up to 5.12 Mb at CD = 0. The formula to determine the maximum speed is as follows:

$$f_{SERIALCLOCK} = \frac{f_{HCLK}}{4}$$

In both master and slave modes, data is transmitted on one edge of the SCL signal and sampled on the other. Therefore, it is important that the polarity and phase are configured the same for the master and slave devices.

CHIP SELECT (\overline{SS}) INPUT PIN

In SPI slave mode, a transfer is initiated by the assertion of \overline{SS} , an active low input signal. The SPI port then transmits and receives eight bits of data until the transfer is concluded by the deassertion of \overline{SS} . In slave mode, \overline{SS} is always an input.

SPI REGISTER DEFINITIONS

The following MMR registers are used to control the SPI interface:

- SPICON: 16-bit control register
- SPISTA: 8-bit read only status register
- SPIDIV: 8-bit serial clock divider register
- SPITX: 8-bit write only transmit register
- SPIRX: 8-bit read only receive register

SPI Control Register

Name: SPICON
Address: 0xFFFF0A10
Default Value: 0x0000
Access: Read/write
Function: The 16-bit MMR configures the serial peripheral interface.

Table 88. SPICON MMR Bit Designations

Bit	Description
15 to 13	Reserved.
12	Continuous Transfer Enable. Set by the user to enable continuous transfer. In master mode, the transfer continues until no valid data is available in the SPITX register. \overline{SS} is asserted and remains asserted for the duration of each 8-bit serial transfer until SPITX is empty. Cleared by the user to disable continuous transfer. Each transfer consists of a single 8-bit serial transfer. If valid data exists in the SPITX register then a new transfer is initiated after a stall period.
11	Loopback Enable. Set by user to connect MISO to MOSI and test software. Cleared by user to be in normal mode.
10	Slave Output Enable. Set by user to enable the slave output. Cleared by user to disable slave output.
9	Slave Select Input Enable. Set by user in master mode to enable the output.
8	SPIRX Overflow Overwrite Enable. Set by the user, the valid data in the SPIRX register is overwritten by the new serial byte received. Cleared by the user, the new serial byte received is discarded.
7	SPITX Underflow Mode. Set by the user to transmit the previous data. Cleared by the user to transmit 0.
6	Transfer and Interrupt Mode (Master Mode). Set by the user to initiate a transfer with a write to the SPITX register. Interrupt occurs when SPITX is empty. Cleared by the user to initiate a transfer with a read of the SPIRX register. Interrupt occurs when SPIRX is full.
5	LSB First Transfer Enable Bit. Set by the user; the LSB is transmitted first. Cleared by the user; the MSB is transmitted first.
4	Reserved.
3	Serial Clock Polarity Mode Bit. Set by user, the serial clock idles high. Cleared by user the serial clock idles low.
2	Serial Clock Phase Mode Bit. Set by the user, the serial clock pulses at the beginning of each serial bit transfer. Cleared by the user, the serial clock pulses at the end of each serial bit transfer.
1	Master Mode Enable Bit. Set by the user to enable master mode. Cleared by the user to enable slave mode.
0	SPI Enable Bit. Set by the user to enable the SPI. Cleared to disable the SPI.

SPI Status Register**Name:** SPISTA**Address:** 0xFFFF0A00**Default Value:** 0x00**Access:** Read only**Function:** The 8-bit MMR represents the current status of the serial peripheral interface.**Table 89. SPISTA MMR Bit Designations**

Bit	Description
7 to 6	Reserved.
5	SPIRX Data Register Overflow Status Bit. Set if SPIRX is overflowing. Cleared by reading the SPIRX register.
4	SPIRX Data Register IRQ. Set automatically if Bit 3 or Bit 5 is set. Cleared by reading the SPIRX register.
3	SPIRX Data Register Full Status Bit. Set automatically if valid data is present in the SPIRX register. Cleared by reading the SPIRX register.
2	SPITX Data Register Underflow Status Bit. Set automatically if SPITX is underflowing. Cleared by writing in the SPITX register.
1	SPITX Data Register IRQ. Set automatically if Bit 0 is clear or Bit 2 is set. Cleared by either writing in the SPITX register or, if finished the transmission, disabling the SPI.
0	SPITX Data Register Empty Status Bit. Set by writing to SPITX to send data. This bit is set during transmission of data. Cleared when SPITX is empty.

SPI Receive Register**Name:** SPIRX**Address:** 0xFFFF0A04**Default Value:** 0x00**Access:** Read only**Function:** This 8-bit MMR contains the data received using the serial peripheral interface.

SPI Transmit Register**Name:** SPITX**Address:** 0xFFFF0A08**Access:** Write only**Function:** Write to this 8-bit MMR to transmit data using the serial peripheral interface.***SPI Divider Register*****Name:** SPIDIV**Address:** 0xFFFF0A0C**Default Value:** 0x1B**Access:** Read/write**Function:** The 8-bit MMR represents the frequency at which the serial peripheral interface is operating. For more information on the calculation of the baud rate, refer to Equation 3.

SERIAL TEST INTERFACE

The ADuC7034 incorporates single pin, serial test interface (STI) ports that can be used for end-customer evaluation or diagnostics on finished production units.

The STI port transmits from 1 to 6 bytes of data in 12-bit packets. As shown in Figure 41, each transmission packet includes a start bit, the transmitted byte (eight bits), an even parity bit, and two stop bits. The STI data is transmitted on the STI pin and the baud rate is determined by the overflow rate of Timer4.

The STI port is configured and controlled via six MMRs.

- STIKEY0: Serial Test Interface Key 0
- STIKEY1: Serial Test Interface Key 1
- STIDAT0: Data0 (16-bit) holds 2 bytes
- STIDAT1: Data1 (16-bit) holds 2 bytes
- STIDAT2: Data2 (16-bit) holds 2 bytes
- STICON: Controls the serial test interface

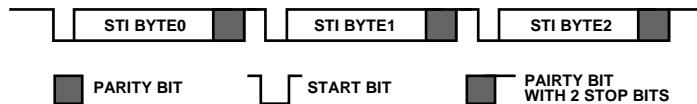

Figure 41. Serial ADC Test Interface Example, Three-Byte Transmission

Serial Test Interface Key0 Register

Name: STIKEY0

Address: 0xFFFF0880

Access: Write only

Function: The STIKEY0 MMR is used in conjunction with the STIKEY1 MMR to protect the STICON MMR. STIKEY0 must be written with 0x0007 immediately before any attempt is made to write to STICON. STIKEY1 must be written with 0x00B9 immediately after STICON is written to ensure the STICON write sequence is completed successfully. If STIKEY0 is not written, is written out of sequence, or is written incorrectly, any subsequent write to the STICON MMR is ignored.

Serial Test Interface Key1 Register

Name: STIKEY1

Address: 0xFFFF0888

Access: Write only

Function: The STIKEY1 MMR is used in conjunction with the STIKEY0 MMR to protect the STICON MMR. STIKEY1 must be written with 0x00B9 immediately after any attempt is made to write to STICON. STIKEY0 must be written with 0x0007 immediately before STICON is written to ensure the STICON write sequence is completed successfully. If STIKEY1 is not written, is written out of sequence, or is written incorrectly, any previous write to the STICON MMR is ignored.

Serial Test Interface Data0 Register

Name: STIDAT0

Address: 0xFFFF088C

Default Value: 0x0000

Access: Read/write

Function: The STIDAT0 MMR is a 16-bit register that holds the first and second data bytes that are to be transmitted on the STI pin as soon as the STI port is enabled. The first byte to be transmitted occupies Bits[0:7] and the second byte occupies Bits[8:15].

Serial Test Interface Data1 Register

Name: STIDAT1
Address: 0xFFFF0890
Default Value: 0x0000
Access: Read/write
Function: The STIDAT1 MMR is a 16-bit register that holds the third and fourth data bytes that are to be transmitted on the STI pin when the STI port is enabled. The third byte to be transmitted occupies Bits[0:7] and the fourth byte occupies Bits[8:15].

Serial Test Interface Data2 Register

Name: STIDAT1
Address: 0xFFFF0894
Default Value: 0x0000
Access: Read/write
Function: The STIDAT2 MMR is a 16-bit register which is used to hold the fifth and sixth data bytes that are to be transmitted on the STI pin when the STI port is enabled. The fifth byte to be transmitted occupies Bits[0:7] and the sixth byte occupies Bits[8:15].

Serial Test Interface Control Register

Name: STICON
Address: 0xFFFF0884
Default Value: 0x0000
Access: Read/write access, write protected by two key registers (STIKEY0 and STIKEY1). A write access to STICON is only completed correctly if the following triple write sequence is followed:
 1. STIKEY0 MMR is written with 0x7.
 2. STICON is written.
 3. The sequence is completed by writing 0xB9 to STIKEY1.
Function: The STI Control MMR is an 16-bit register that configures the mode of operation of the serial test interface.
Note: GPIO_13 must be configured for STI operation in GP2CON for STI communications.

Table 90. STICON MMR Bit Designations

Bit	Description
16 to 9	Reserved. These bits are reserved for future use and should be written as 0 by user code.
8 to 5	State Bits, Read Only. If the interface is in the middle of a transmission, these bits are not 0.
4 to 2	Number of Bytes to Transmit. These bits select the number of bytes to be transmitted. User code must subsequently write the bytes to be transmitted into the STIDAT0, STIDAT1, and STIDAT2 MMRs. 0, 0, 0 = 1-byte transmission. 0, 0, 1 = 2-byte transmission. 0, 1, 0 = 3-byte transmission. 0, 1, 1 = 4-byte transmission. 1, 0, 0 = 5-byte transmission. 1, 0, 1 = 6-byte transmission.
1	Reset Serial Test Interface. This bit is set to a 1 to reset the serial test interface, a subsequent read of STICON returns all 0s. This bit is 0 by default to operate in normal mode.
0	Serial Test Interface Enable. This bit is set to a 1 by user code to enable the serial test interface. This bit is set to 0 by user code to disable the serial test interface.

Serial Test Interface Output Structure

The serial test interface is a high voltage output that incorporates a low-side driver, short-circuit protection, and diagnostic pin readback capability. The output driver circuit configuration is shown in Figure 42.

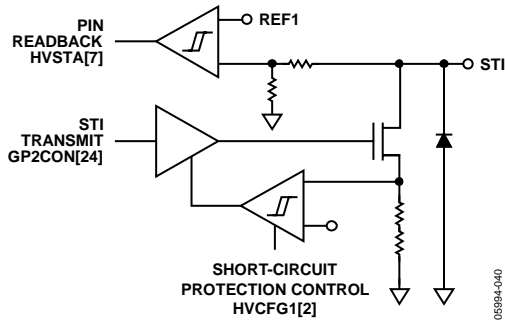

Figure 42. STI Output Structure

Using the Serial Test Interface

Data only begins transmission when configuration of the STI port has been completed in the following sequence:

1. Configure Timer4 for baud rate generation.
2. Correctly enable STICON using STIKEY0 and STIKEY1 for secure access.
3. Required bytes to be transmitted are written into STIDAT0, STIDAT1, and STIDAT2.

Timer4 is configured with the correct load value to generate an overflow at the required baud rate. If the STI port is being used to transmit ADC conversion results, then the baud rate must be

sufficient to output each ADC result (16-bits) prior to the next ADC conversion result being available.

For example, if the ADC is sampling at 1 kHz, then the baud rate has to be sufficient to output 36 bits as follows:

$$(3 \times 8 \text{ bits (16-bit ADC result and a checksum byte, for example)}) + (3 \times 1 \text{ start bit}) + (3 \times 1 \text{ parity bit}) + (3 \times 2 \text{ stop bits}) = 36 \text{ bits}$$

Therefore, the serial test interface must transmit data at greater than 36 kbps. The closest standard baud rate is 38.4 kbps; as such, the reload value written to the Timer4 load MMR (T4LD) is 0x0106 (267 decimal). This value is calculated as follows, and is based on a prescaler of 1, using a core clock of 10.24 MHz:

$$T4LD = \frac{\text{Core Clock Frequency}}{\text{Desired Baud Rate}} = \frac{10.24 \text{ MHz}}{38.4 \text{ kbps}} = 267$$

When the Timer4 load value is written and the timer itself is configured and enabled using the T4CON MMR, the STI port must be configured. This is accomplished by writing to the STICON MMR in a specific sequence using the STIKEY0 and STIKEY1 MMRs as described in the previous sections.

Finally, the STI port does not begin transmission until the required number of transmit bytes are written into the STIDATx MMRs. As soon as STI starts transmitting, the value in the STICON MMR changes from the value initially written to this register. User code can ensure that all data is transmitted by continuously polling the STICON MMR until it reverts back to the value originally written to it. To disable the serial interface, user code must write a 0 to STICON[0].

An example code segment configuring the STI port to transmit five bytes and then to transmit two bytes follows:

```
T4LD = 267;           // Timer4 Reload Value
T4CON = 0xC0;        // Enable T4, selecting core clock in periodic mode

STIKEY0 = 07;       // STICON start write sequence
STICON = 0x11;     // Enable and transmit 5 bytes
STIKEY1 = 0xb9;    // STICON complete write

STIDAT0 = 0xAABB;  // 5 bytes for
STIDAT1 = 0xCCDD; // transmission
STIDAT2 = 0xFF;

while(STICON != 0x09) // wait for transmission to complete
{
}

STIKEY0 = 07;       // STICON start write sequence
STICON = 0x05;     // Enable and transmit 2 bytes
STIKEY1 = 0xb9;    // STICON complete write

STIDAT0 = 0xEEFF;  // 2 bytes for transmission

while(STICON != 0x09) // wait for transmission to complete
{
}
```

LIN (LOCAL INTERCONNECT NETWORK) INTERFACE

The ADuC7034 features high voltage physical interfaces between the ARM7 MCU core and an external LIN bus. The LIN interface operates as a slave only interface, operating from 1 kBaud to 20 kBaud, and it is compatible with the LIN 2.0 standard. The pull-up resistor required for a slave node is on-chip, reducing the need for external circuitry. The LIN protocol is emulated using the on-chip UART, an IRQ, a dedicated LIN timer, and the high voltage transceiver (also incorporated on-chip) as shown in Figure 43. The LIN is clocked from the low power oscillator for the break timer, and a 5 MHz output from the PLL is used for the synchronous byte timing.

LIN MMR DESCRIPTION

The LIN hardware synchronization (LHS) functionality is controlled through five MMRs. The function of each MMR is as follows:

- LHSSTA: LHS Status Register. This MMR contains information flags that describe the current status on the interface.
- LHSCON0: LHS Control Register 0. This MMR controls the configuration of the LHS timer.
- LHSCON1: LHS Start and Stop Edge Control Register. Dictates which edge of the LIN synchronization byte the LHS starts/stops counting.
- LHSVAL0: LHS Synchronization 16-Bit Timer. Controlled by LHSCON0.
- LHSVAL1: LHS Break Timer Register.

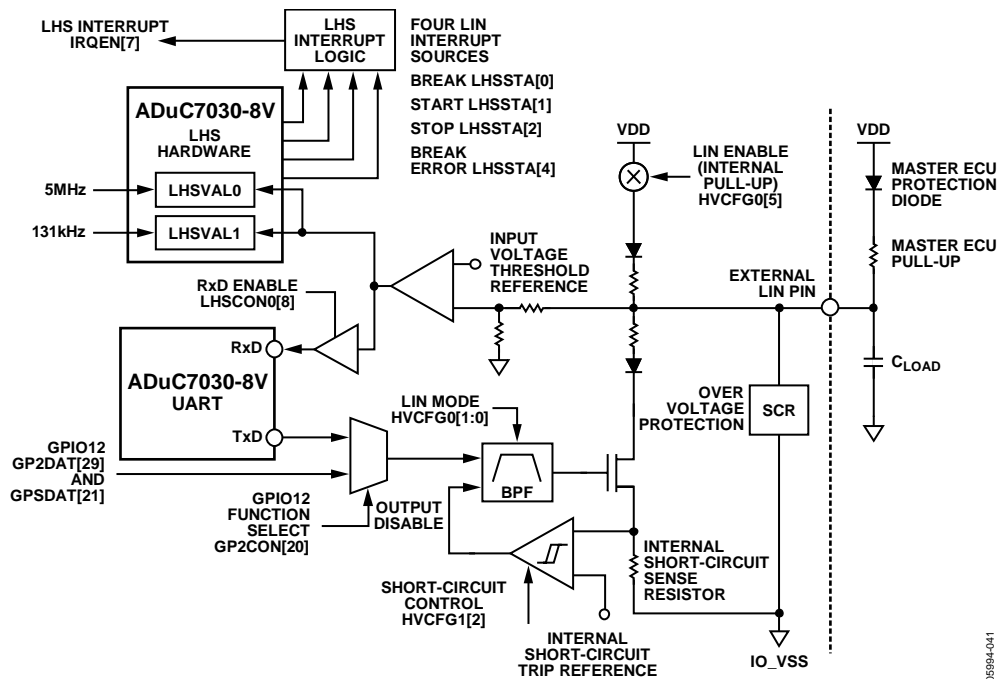

Figure 43. LIN I/O, Block Diagram

05994-041

LIN Hardware Synchronization Status Register**Name:** LHSSTA**Address:** 0xFFFF0780**Default Value:** 0x00000000**Access:** Read only**Function:** The LHS status register is a 32-bit register whose bits reflect the current operating status of the ADuC7034 LIN interface.**Table 91. LHSSTA MMR Bit Designations**

Bit	Description
31 to 7	Reserved. These read only bits are reserved for future use.
6	Rising Edge Detected (BSD Mode Only). This bit is set to 1 by hardware to indicate a rising edge has been detected on the BSD bus. This bit is cleared to 0, after user code reads the LHSSTA MMR.
5	LHS Reset Complete Flag. This bit is set to 1 by hardware to indicate a LHS reset command has completed successfully. This bit is cleared to 0, after user code reads the LHSSTA MMR.
4	Break Field Error. This bit is set to 1 by hardware and generates an LHS interrupt (IRQEN[7]) when the 12-bit, break timer (LHSVAL1) register overflows to indicate the LIN bus has stayed low too long, thus indicating a possible LIN bus error. This bit is cleared to 0, after user code reads the LHSSTA MMR.
3	LHS Compare Interrupt. This bit is set to 1 by hardware when the value in LHSVAL0 (LIN synchronization bit timer) = the value in the LHSCMP register. This bit is cleared to 0, after user code reads the LHSSTA MMR.
2	Stop Condition Interrupt. This bit is set to 1 by hardware when a stop condition is detected. This bit is cleared to 0, after user code reads LHSSTA MMR.
1	Start Condition Interrupt. This bit is set to 1 by hardware when a start condition is detected. This bit is cleared to 0, after user code reads LHSSTA MMR.
0	Break Timer Compare Interrupt. This bit is set to 1 by hardware when a valid LIN break condition is detected. A LIN break condition is generated when the LIN break timer value reaches the break timer compare value (see LHSVAL1 in the LIN Hardware Break Timer1 Register section for more information). This bit is cleared to 0 after user code reads the LHSSTA MMR.

LIN Hardware Synchronization Control Register 0

Name:	LHSCON0
Address:	0xFFFF0784
Default Value:	0x00000000
Access:	Read/write
Function:	The LHS control register is a 32-bit register that, in conjunction with the LHSCON1 register, is used to configure the LIN mode of operation.

Table 92. LHSCON0 MMR Bit Designations

Bit	Description
31 to 13	Reserved. These bits are reserved for future use and should be written as 0 by user software.
12	<p>Rising Edge Detected Interrupt Disable.</p> <p>BSD Mode. This bit is set to 1 to disable the rising edge detected interrupt. This bit is cleared to 0 to enable the break rising edge detected interrupt.</p> <p>LIN Mode. This bit is set to 1 to enable the rising edge detected interrupt. This bit is cleared to 0 to disable the break rising edge detected interrupt.</p>
11	<p>Break Timer Compare Interrupt Disable.</p> <p>This bit is set to 1 to disable the break timer compare interrupt. This bit is cleared to 0 to enable the break timer compare interrupt.</p>
10	<p>Break Timer Error Interrupt Disable.</p> <p>This bit is set to 1 to disable the break timer error interrupt. This bit is cleared to 0 to enable the break timer error interrupt.</p>
9	<p>LIN Transceiver, Standalone Test Mode.</p> <p>This bit is cleared to 0 by user code to operate the LIN in normal mode, it is driven directly from the on-chip UART. This bit is set to 1 by user code to enable external GPIO_7 and GPIO_8 pins to drive the LIN Transceiver TxD and LIN Transceiver RxD, respectively, independent of the UART. The functions of GPIO_7 and GPIO_8 should first be configured by user code via the GPIO function select Bit 0 and Bit 4 in the GP2CON register.</p>
8	<p>Gate UART/BSD R/W Bit.</p> <p>This bit is set to 1 by user code to disable the internal UART RxD (receive data) by gating it high until both the break field and subsequent LIN sync byte have been detected. This ensures the UART does not receive any spurious serial data during break or sync field periods that have to be flushed out of the UART before valid data fields can start to be received.</p> <p>This bit is set to 0 by user code to enable the internal UART RxD (receive data) after the break field and subsequent LIN sync byte have been detected so that the UART can receive the subsequent LIN data fields.</p> <p>In BSD mode (LHSCON0<6>) is set to 1. Because of the finite propagation delay in the BSD transmit (from the MCU to the external pin) and receive (from the external pin to the MCU) paths, user code must not switch between BSD write and read modes until the MCU confirms the external BSD pin is deasserted. Failure to adhere to this recommendation can result in the generation of an inadvertent break condition interrupt after user code switches from BSD write mode to BSD read mode. A stop condition interrupt can be used to ensure that this scenario is avoided.</p> <p>In BSD read mode, this bit is set to 1 by user code to enable the generation of a break condition interrupt (LHSSTA[0]) on a rising edge of the BSD bus. In BSD read mode, the break timer (LHSVAL1) starts counting on the falling edge and stops counting on the rising edge. The generation of an interrupt on this rising edge allows user code to determine if a 0, 1, or sync pulse width has been received. It should also be noted that the break timer still generates an interrupt if the value in the LIN break timer (LHSVAL1 read value) equals the break timer compare value (LHSVAL1 write value), and if the break timer overflows. This configuration can be used in BSD read mode to detect fault conditions on the BSD bus.</p> <p>In BSD write mode, this bit is cleared to 0 by user code to disable the generation of break condition interrupts on a rising edge of the BSD bus (as is required in BSD read mode). In BSD write mode, the LHS compare interrupt (LHSSTA[3]) is used to determine when the MCU should release the BSD bus when transmitting data. If the break condition interrupt was still enabled it would generate an unwanted interrupt as soon as the BSD bus is deasserted. As in BSD read mode, the break timer stops counting on a rising edge so the break timer can also be used in this mode to allow user code to confirm the pulse width in transmitted data bits.</p>

Bit	Description
7	<p>Sync Timer Stop Edge Type Bit.</p> <p>This bit is cleared to 0 by user code to stop the sync timer on the falling edge count configured through the LHSCON1[7:4] register.</p> <p>This bit is set to 1 by user code to stop the sync timer on the rising edge count configured through the LHSCON1[7:4] register.</p>
6	<p>Mode of Operation Bit.</p> <p>This bit is cleared to 0 by user code to select LIN mode of operation.</p> <p>This bit is set to 1 by user code to select BSD mode of operation.</p>
5	<p>Enable Compare Interrupt Bit.</p> <p>This bit is cleared to 0 by user code to disable compare interrupts.</p> <p>This bit is set to 1 by user code to generate an LHS interrupt (IRQEN[7]) when the value in LHSVAL0 (LIN synchronization bit timer) = the value in the LHSCMP register. The LHS Compare Interrupt Bit LHSSTA[3] is set when this interrupt occurs. This configuration is used in BSD write mode to allow user code correctly time the output pulse widths of BSD bits to be transmitted.</p>
4	<p>Enable Stop Interrupt.</p> <p>This bit is cleared to 0 by user code to disable interrupts when a stop condition occurs.</p> <p>This bit is set to 1 by user code to generate an interrupt when a stop condition occurs.</p>
3	<p>Enable Start Interrupt.</p> <p>This bit is cleared to 0 by user code to disable interrupts when a start condition occurs.</p> <p>This bit is set to 1 by user code to generate an interrupt when a start condition occurs.</p>
2	<p>LIN Sync Enable Bit.</p> <p>This bit is cleared to 0 by user code to disable LHS functionality.</p> <p>This bit is set to 1 by user code to enable LHS functionality.</p>
1	<p>Edge Counter Clear Bit.</p> <p>This bit is set to 1 by user code to clear the internal edge counters in the LHS peripheral.</p> <p>This bit is automatically cleared to 0 after a 15 μs delay.</p>
0	<p>LHS Reset Bit.</p> <p>This bit is set to 1 by user code to reset all LHS logic to default conditions.</p> <p>This bit is automatically cleared to 0 after a 15 μs delay.</p>

LIN Hardware Synchronization Control Register 1

Name:	LHSCON1
Address:	0xFFFF078C
Default Value:	0x00000032
Access:	Read/write
Function:	The LHS control register is a 32-bit register that, in conjunction with the LHSCON0 register, is used to configure the LIN mode of operation.

Table 93. LHSCON1 MMR Bit Designations

Bit	Description
31 to 8	Reserved. These bits are reserved for future use and should be written as 0 by user software.
7 to 4	LIN Stop Edge Count. These bits are set by user code to the number of falling or rising edges on which to stop the internal LIN synchronization counter. The stop value of this counter can be read by user code using LHSVAL0. The type of edge, either rising or falling, is configured by LHSCON0[7]. The default value of these bits is 0x3 which configures the hardware to stop counting on the third falling edge. It should be noted that the first falling edge is taken as the falling edge at the start of the LIN break pulse.
3 to 0	LIN Start Edge Count. These four bits are set by user code to the number of falling edges after which the internal LIN synchronization timer starts counting. The stop value of this counter can be read by user code using LHSVAL0. The default value of these bits is 0x2 which configures the hardware to start counting on the second falling edge. Note that the first falling edge is taken as the falling edge at the start of the LIN break pulse.

LIN Hardware Synchronization Timer0 Register

Name:	LHSVAL0
Address:	0xFFFF0788
Default Value:	0x0000
Access:	Read only
Function:	The 16-bit, read only LHSVAL0 register holds the value of the internal LIN synchronization timer. The LIN synchronization timer is clocked from an internal 5 MHz clock and is independent of core clock and baud rate frequency. In LIN mode, the value read by user code from the LHSVAL0 register can be used calculate the master LIN baud rate. This calculation is then used to configure the internal UART baud rate to ensure correct LIN communication via the UART from the ADuC7034 slave to the LIN master node.

LIN Hardware Break Timer1 Register

Name:	LHSVAL1
Address:	0xFFFF0790
Default Value:	0x000(read) or 0x047(write)
Access:	Read/write
Function:	<p>When user code reads this location, the 12-bit value returned is the value of the internal LIN break timer. This is clocked directly from the on-chip low power (131 kHz) oscillator and it times the LIN break pulse. A negative edge on the LIN bus or user code reading the LHSVAL1 results in the timer and the register contents being reset to 0.</p> <p>When user code writes to this location, the 12-bit value is written not to the LIN break timer, but to a LIN break compare register. In LIN mode of operation, the value in the compare register is continuously compared to the break timer value. A LIN break interrupt (IRQEN[7] and LHSSTA[0]) is generated when the timer value reaches the compare value. After the break condition interrupt, the LIN break timer continues to count until the rising edge of the break signal. If a rising edge is not detected and the 12-bit timer overflows ($4096 \times 1/131 \text{ kHz} = 31 \text{ ms}$), a break field error interrupt (IRQEN[7] and LHSSTA[4]) is generated. By default, the value in the compare register is 0x47 corresponding to 11 bit periods, that is, the minimum pulse width for a LIN break pulse at 20 kbps. For different baud rates, this value can be changed by writing to LHSVAL1. Note that if a valid break interrupt is not received, then subsequent sync pulse timing through the LHSVAL0 register does not occur.</p>

LIN HARDWARE INTERFACE

LIN Frame Protocol

The LIN frame protocol is broken into four main categories: break symbol, sync byte, protected identifier, and data bytes.

The format of the frame header, break, synchronization byte, and protected identifier are shown in Figure 44. Essentially, the embedded UART, LIN hardware synchronization logic, and the high voltage transceiver interface all combine on-chip to support and manage LIN-based transmissions and receptions.

LIN Frame Break Symbol

As shown in Figure 45, the LIN break symbol is used to signal the start of a new frame. It lasts at least 13 bit periods and a slave must be able to detect a break symbol, even if it expects data or is in the process of receiving data. The ADuC7034 accomplishes this by using the LHSVAL1 break condition and break error detect functionality as described earlier. The break period does not have to be accurately measured, but if a bus fault condition (bus held low) occurs, it must be flagged.

LIN Frame Synchronization Byte

The baud rate of the communication using LIN is calculated from the sync byte, as shown in Figure 46. The time between the first falling edge of the sync field and the fifth falling edge of the sync field is measured. This result is divided by eight to give the baud rate of the data that is going to be transmitted. The ADuC7034 implement the timing of this sync byte in hardware. For more information on this feature, please refer to the LIN Hardware Synchronization Status Register section.

LIN Frame Protected Identifier

After receiving the LIN sync field, the required baud rate for the UART is calculated. The UART is then configured, allowing the ADuC7034 to receive the protected identifier, as shown in Figure 47. The protected identifier consists of two subfields: the identifier and the identifier parity. The six-bit identifier contains the identifier of the target for the frame. The identifier signifies the number of data bytes to be either received or transmitted. The number of bytes is user-configurable at the system level design. The parity is calculated on the identifier, and is dependent on the revision of LIN for which the system is designed.

LIN Frame Data Byte

The data byte frame carries between one and eight bytes of data. The number of bytes contained in the frame is dependent on the LIN master. The data byte frame is split into data bytes as shown in Figure 48.

LIN Frame Data Transmission and Reception

When the break symbol and synchronization byte have been correctly received, data is transmitted and received via the COMTX and COMRX MMRs, after configuration of the UART to the required baud rate. To configure the UART for use with LIN requires the use of the following UART MMRs:

COMDIV0: divisor latch (low byte).

COMDIV1: divisor latch (high byte).

COMDIV2: 16-bit fractional baud divide register. The required values for COMDIV0, COMDIV1, and COMDIV2 are derived from the LHSVAL0, to generate the required baud rate.

COMCON0: line control register. As soon as the UART is correctly configured, the LIN protocol for receiving and transmitting data is identical to the UART specification.

To manage data on the LIN bus requires use of the following UART MMRs:

COMTX: 8-bit transmit register.

COMRX: 8-bit receive register.

COMCON0: line control register.

COMSTA0: line status register.

To transmit data on the LIN bus requires that the relevant data be placed into COMTX. To read data received on the LIN bus requires the monitoring of COMRX. To ensure that data is received or transmitted correctly, COMSTA0 is monitored. For more information refer to the UART Serial Interface and UART Register Definition sections of this data sheet.

Under software control, it is possible to multiplex the UART data lines (TxD and RxD) to external GPIO pins (GPIO_7 and GPIO_8). For more information, refer to the description of the GPIO Port1 Control Register (GP1CON) section.

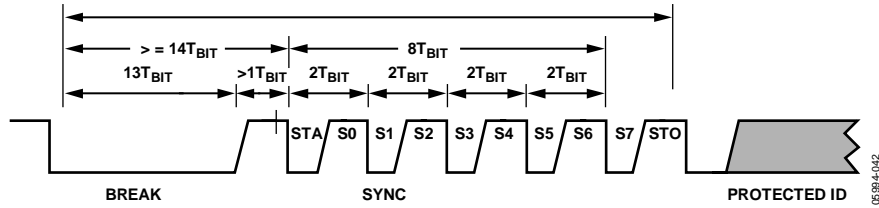

Figure 44. LIN Interface Timing

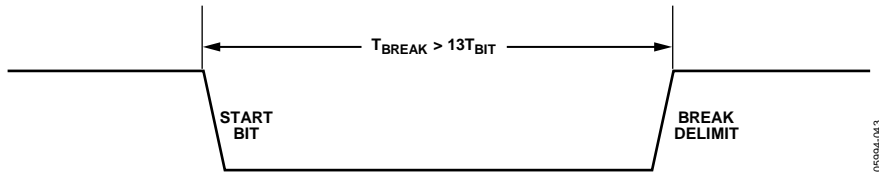

Figure 45. LIN Break Field

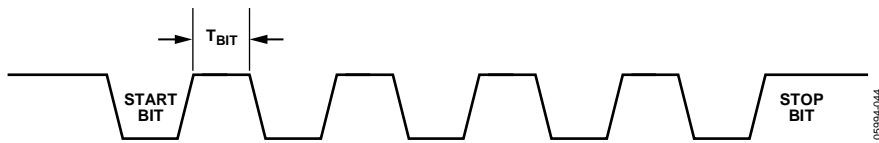

Figure 46. LIN Sync Byte Field

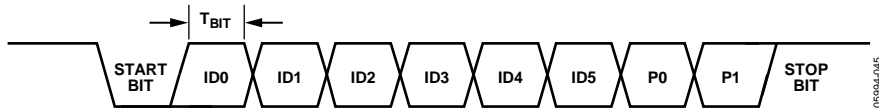

Figure 47. LIN Identifier Byte Field



Figure 48. LIN Data Byte Field

Example LIN Hardware Synchronization Routine

Consider the following C-Source Code LIN initialization routine.

```
void LIN_INIT(void )
{
    char HVstatus;
    GP2CON = 0x110000; // Enable LHS on GPIO pins

    LHSCON0 = 0x1;      // Reset LHS interface

    do{
        HVDAT = 0x02; // Enable normal LIN TX mode
        HVCON = 0x08; // Write to Config0
        do{
            HVstatus = HVCON;
        }
        while(HVstatus & 0x1); // Wait until command is finished
    }
    while (!(HVstatus & 0x4)); // Transmit command is correct

    while((LHSSTA & 0x20) == 0 )
    {
        // Wait until the LHS hardware is reset
    }

    LHSCON1 = 0x062; // Sets Stop Edge as the fifth falling edge
                    // and the Start Edge as the first falling
                    // edge in the sync byte
    LHSCON0 = 0x0114; // Gates UART RX line, ensure no interference
                    // from the LIN into the UART
                    // Selects the Stop Condition as a falling edge
                    // Enables generation of an Interrupt on the
                    // Stop Condition
                    // Enables the interface
    LHSVAL1 = 0x03F; // Set number of 131 kHz periods to generate a Break Interrupt
                    // 0x3F / 131 kHz ~ 480 us which is just over 9.5 TBits

```

Using this configuration, LHSVAL1 begins to count on the first falling edge received on the LIN bus. If LHSVAL1 exceeds the value written to LHSVAL1, in this case 0x3F, a break compare interrupt is generated.

On the next falling edge, LHSVAL0 begins counting. LHSVAL0 monitors the number of falling edges and compares this to the value written to LHSCON1[7:4]. In this example, the number of edges to monitor is the sixth falling edge of the LIN frame, or

the fifth falling edge of the sync byte. When this number of falling edges is received, a stop condition interrupt is generated. It is at this point that the UART is configured to receive the protected identifier.

The UART must not be ungated (through LHSCON0[8]) before the LIN bus returns high. If this occurs, UART communication errors can occur. This process is shown in detail in Figure 49. Example code to ensure this is as follows:

```

while((GP2DAT & 0x10 ) == 0 )
{
    // Wait until LIN Bus returns high
}
LHSCON0 = 0x4;      // Enable LHS to detect Break Condition Ungate RX Line
                    // Disable all Interrupts except Break Compare Interrupt
IRQEN = 0x800;     // Enable UART Interrupt
                    // The UART is now configured and ready to be used for LIN
    
```

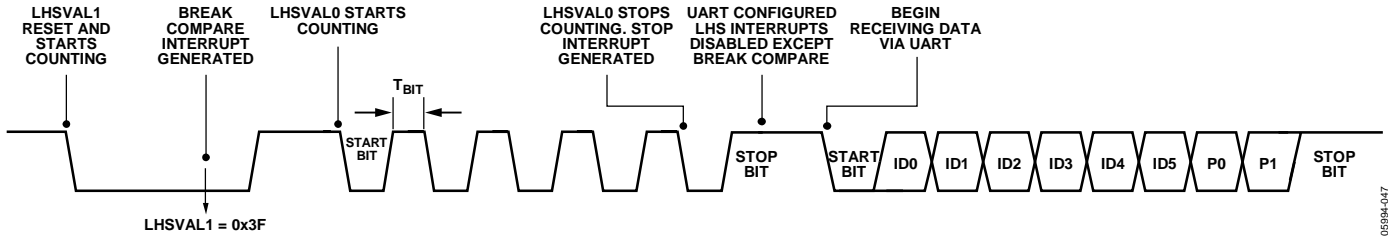

Figure 49. Example LIN Configuration

LIN Diagnostics

The ADuC7034 features the capability to unintrusively monitor the current state of the LIN pin. This readback functionality is implemented using GPIO_11. The current state of the LIN pin is contained in GP2DAT[4].

It is also possible to drive the LIN pin high and low through user software, allowing the user to detect open-circuit conditions. This functionality is implemented via GPIO_12. To enable this functionality, GPIO_12 must be configured as a GPIO through GP2CON[20]. After it is configured, the LIN pin can be pulled high or low using GP2DAT.

The ADuC7034 also features short-circuit protection on the LIN pin. If a short-circuit condition is detected on the LIN pin, HVSTA[2] is set. This bit is cleared by re-enabling the LIN driver using HVCFG1[3]. It is possible to disable this feature through HVCFG1[2].

LIN Operation During Thermal Shutdown

When a thermal event occurs, that is, HVSTA[3] is set, LIN communications continue uninterrupted.

BIT SERIAL DEVICE (BSD) INTERFACE

BSD is a pulse-width modulated signal with three possible states: sync, zero, and one. These are detailed, along with their associated tolerances, in Table 94. The frame length is 19 bits and communication occurs at 1200 bps $\pm 3\%$.

BSD COMMUNICATION HARDWARE INTERFACE

The ADuC7034 emulates the BSD communication protocol using a GPIO, an IRQ, and the LIN synchronization hardware, all of which are under software control.

Table 94. BSD Bit Level Description

Parameter	Min	Typ	Max	Unit
TxD Rate	1164	1200	1236	bps
Bit Encoding				
t_{SYNC}	1/16	2/16	3/16	t_{PERIOD}
t_0	5/16	6/16	8/16	t_{PERIOD}
t_1	10/16	12/16	14/16	t_{PERIOD}

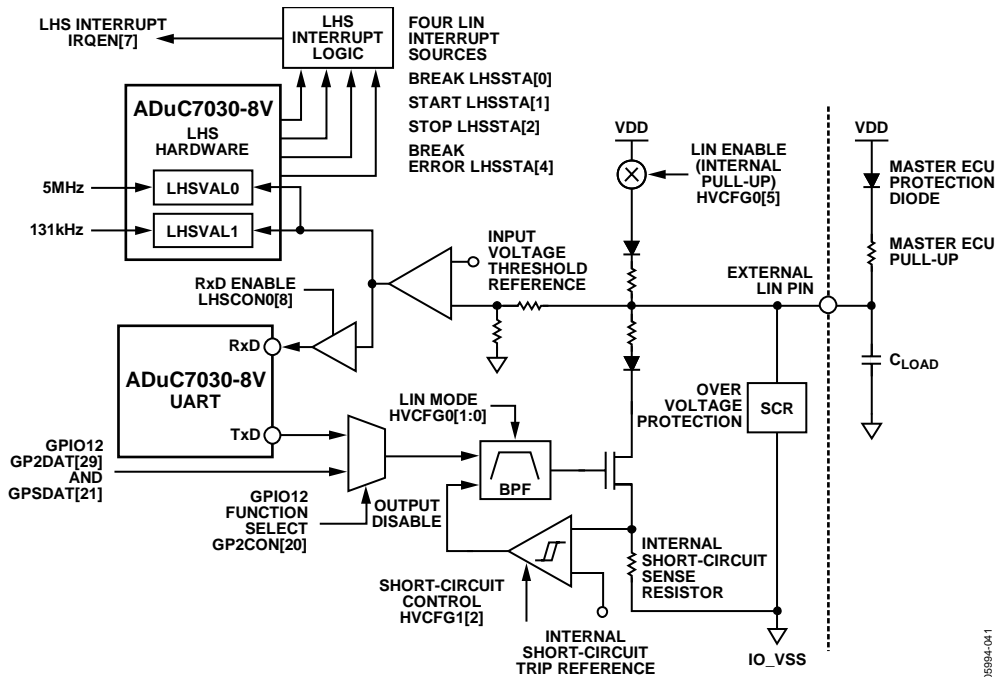

Figure 50. BSD I/O Hardware Interface

06994-041

BSD RELATED MMRS

The ADuC7034 emulates the BSD communication protocol using a software (bit bang) interface with some hardware assistance form LIN hardware synchronization logic. In effect, the ADuC7034 BSD interface uses the following protocols:

- An internal GPIO signal (GPIO_12) that is routed to the external LIN/BSD pin and is controlled directly by software to generate 0s and 1s.
- When reading bits, the LIN synchronization hardware uses LHSVAL1 to count the width of the incoming pulses so that user code can interpret the bits as sync, 0, or 1.
- When writing bits, user code toggles a GPIO pin and uses the LHSCAP and LHSCMP registers to time pulse widths and generate an interrupt when the BSD output pulse width has reached its required width.

The ADuC7034 MMRs required for BSD communication are as follows:

LHSSTA:	LIN Hardware Sync Status Register.
LHSCON0:	LIN Hardware Sync Control Register.
LHSVAL0:	LIN Hardware Sync Timer0 (16-Bit Timer).
LHSCON1:	LIN Hardware Sync Edge Setup Register.
LHSVAL1:	LIN Sync Break Timer.
LHSCAP:	LIN Sync Capture Register.
LHSCMP:	LIN Sync Compare Register.
IRQEN/CLR:	Enable Interrupt Register.
FIQEN/CLR:	Enable Fast Interrupt Register.
GP2DAT:	GPIO Data Register.
GP2SET:	GPIO Set Register.
GP2CLR:	GPIO Clear Register.

Detailed bit definitions for most of these MMRs have been listed previously. In addition to the registers described in the LIN MMR Description section, LHSCAP and LHSCMP are

new registers that are required for the operation of the BSD interface. Details of these registers follow.

LIN Hardware Synchronization Capture Register

Name:	LHSCAP
Address:	0xFFFF0794
Default Value:	0x0000
Access:	Read only
Function:	The 16-bit, read only LHSCAP register holds the last captured value of the internal LIN synchronization timer (LHSVAL0). In BSD mode, the LHSVAL0 is clocked directly from an internal 5 MHz clock, its value is loaded into the capture register on every falling edge of the BSD bus.

LIN Hardware Synchronization Compare Register

Name:	LHSCMP
Address:	0xFFFF0798
Default Value:	0x0000
Access:	Read/write
Function:	The LHSCMP register is used to time BSD output pulse widths. When enabled through LHSCON0[5], a LIN interrupt is generated when the value in LHSCAP equals the value written in LHSCMP. This functionality allows user code to determine how long a BSD transmission bit (SYNC, 0, or 1) should be asserted on the bus.

BSD COMMUNICATIONS FRAME

To transfer data between a master and slave, or vice versa, the construction of a BSD frame is required. A BSD frame contains seven key components: pause/sync, direction bit, the slave address, the register address, data, Parity Bit 1 (P1) and Parity Bit 2 (P2), and the acknowledge from the slave.

If the master is transmitting data, then all bits except the acknowledge bit, are transmitted by the master.

If the master is requesting data from the slave, the master transmits the pause/sync, the direction bit, slave address, register address, and P1 bits. The slave then transmits the data bytes, P 2, and the acknowledge in the following sequence:

1. PAUSE: \geq three synchronization pulses.
2. DIR: signifies the direction of data transfer.
 - a. Zero (0) if master sends request.
 - b. One (1) if slave sends request.
3. Slave Address.
4. Register Address: defines register to be read or written.
5. Bit 3 is set to write, cleared to read.
6. Data: 8-bit read only receive register.
7. P1 and P2.
 - a. P1 = 0 if even number of 1s in 8 previous bits.
 - b. P1 = 1 if odd number of 1s in 8 previous bits.
 - c. P2 = 0 if even number of 1s in data-word.
 - d. P2 = 1 if odd number of 1s in data-word.
8. Acknowledge: zero (0) if transmission is successful.

The acknowledge is always transmitted by the slave to indicate if the information was received or transmitted.

Table 95. BSD Protocol Description

Pause	DIR	Slave Address	Register Address	P1	Data	P2	ACK
3 bits	1 bit	3 bits	4 bits	1 bit	8 bits	1 bit	1 bit

BSD Example Pulse Widths

An example of the different pulse widths is shown in Figure 51. For each bit, the period for which the bus is held low defines what type of bit it is. If the bit is a sync bit, the pulse is held low for one bit. If the bit is a zero bit, the pulse is held low for three bits. If the bit is a one bit, the pulse is held low for six bits.

If the master is transmitting data, the signal is held low for the duration of the signal by the master. An example of a master transmitting zero is shown in Figure 52. If the slave is transmitting data, the master pulls the bus low to begin communications. The slave must then pull the bus low before t_{SYNC} elapses and hold the bus low until either t_0 or t_1 has elapsed, after which time the bus is released by the slave. An example of a slave transmitting a zero is shown in Figure 53.

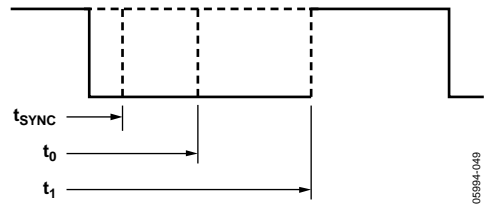

Figure 51. BSD Bit Transmission

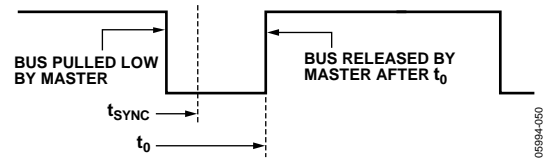

Figure 52. BSD Master Transmitting Zero

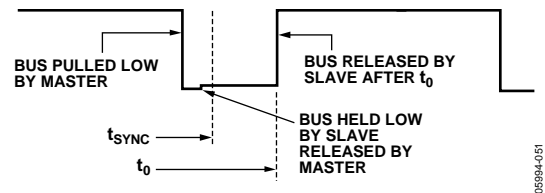

Figure 53. BSD Slave Transmitting Zero

Typical BSD Program Flow

Because BSD is a PWM communications protocol controlled by software; it is necessary for the user to construct the required data from each bit. For example, in constructing the slave address, the slave node receives the three bits and the user constructs the relevant address.

When BSD communication is initiated by the master, data is transmitted and received by the slave node. A flow diagram showing this process is shown in Figure 54.

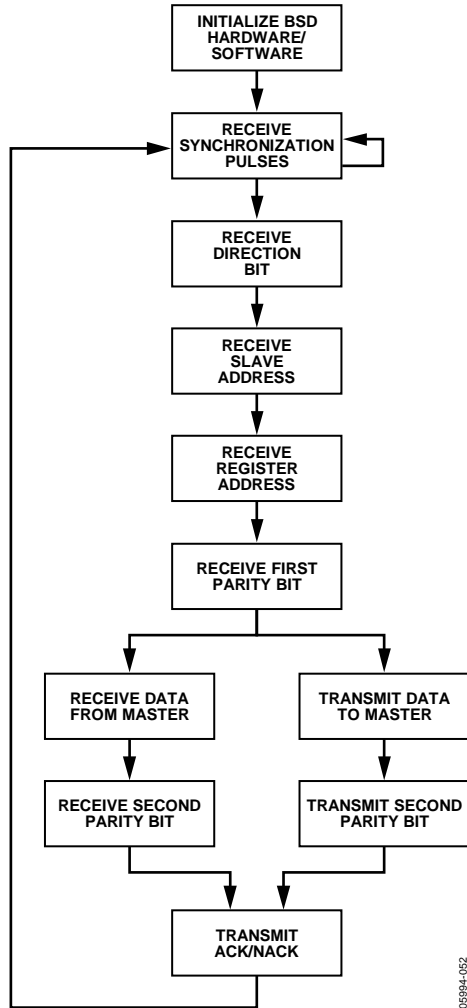

Figure 54. BSD Slave Node State Machine

BSD DATA RECEPTION

To receive data, the LIN/BSL peripheral must first be configured in BSD mode where LHS CON[6] = 1. In this mode, LHS CON0[8] should be set to ensure the LHS break timer (see LHS VAL1 in the LIN Hardware Break Timer1 Register section) generates an interrupt on the rising edge of the BSD bus.

The LHS break timer is cleared and starts counting on the falling edge of the BSD bus and is subsequently stopped and generates an interrupt on the rising edge of the BSD bus. Given that the LHS break timer is clocked by the low power (131 kHz) oscillator, the value in LHS VAL1 can be interpreted by user code to determine if the received data bit is a BSD sync pulse, 0, or 1.

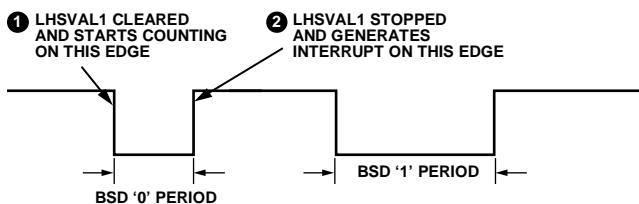

Figure 55. Master Transmit, Slave Read

BSD DATA TRANSMISSION

User code forces a GPIO signal (GPIO_12) low for a specified time to transmit data in BSD mode. In addition, user code also uses the sync timer (LHS VAL0), LHS sync capture register (LHSCAP), and the LHS sync compare register (LHSCMP) to time how long the BSD bus should be held low for 0 or 1 bit transmissions.

As described earlier, even when the slave is transmitting, the master always starts the bit transmission period by pulling the BSD bus low. If BSD mode is selected (LHS CON0[6] = 1), then the LIN sync timer value is captured in LHSCAP on every falling edge of the BSD bus. The LIN sync timer runs continuously in BSD mode.

User code can then immediately force GPIO_12 low and reads the captured timer value from LHSCAP. A calculation of how many (5 MHz) clock periods should elapse before the GPIO_12 should be driven high for a 0 or 1 pulse width can be made. This number can be added to the LHSCAP value and written into the LHSCMP register. If LHS CON0[5] is set, the sync timer, which continues to count (being clocked by a 5 MHz clock), eventually equals the LHSCMP value and generates an LHS compare interrupt (LHS STA[3]).

The response to this interrupt should be to force the GPIO_12 signal (and, therefore, the BSD bus) high. The software control of the GPIO_12 signal along with the correct use of the LIN synchronization timers ensures that valid 0 and 1 pulse widths can be transmitted from the ADuC7034 as shown in Figure 56. Again, care needs to be taken if switching from BSD write mode to BSD read mode as described in LHS CON0[8].

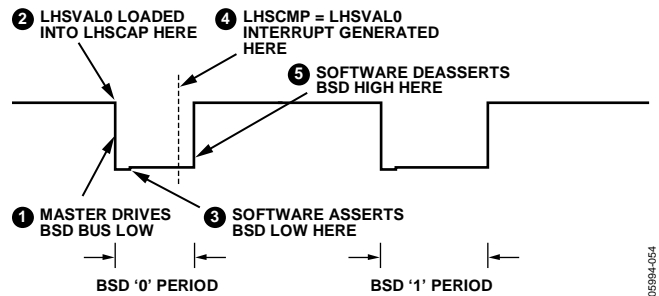

Figure 56. Master Read, Slave Transmit

WAKE-UP FROM BSD INTERFACE

The MCU core can be woken up from power-down via the BSD physical interface. Before entering power-down mode, user code should enable the start condition interrupt (LHS CON0[3]). When this interrupt is enabled, a high to low transition on the LIN/BSL pin generates an interrupt event and wakes up the MCU core.

PART IDENTIFICATION

Two registers mapped into the MMR space are intended to allow user code to identify and trace manufacturing lot ID information, part ID number, silicon mask revision, and kernel revision. This information is contained in the SYSSER0 and SYSSER1 MMR. See Table 97 for details.

Part number is contained in the MMR FEE0ADR at power up.

For direct traceability, the assembly lot ID is also available. The assembly lot ID can be 64-bit long. The SYSALI MMR contains the 32-bit lower half of the assembly lot ID. The upper half is contained in the T1LD MMR at power up.

The information contained in SYSSER0, SYSSER1 and assembly lot ID allows full traceability of each part.

The lot number is part of the branding on the package as shown Table 96.

Table 96. Branding Example

Line	LFCSF
Line 1	ADuC7034
Line 2	BCPZ S1
Line 3	A4Y #Date Code
Line 4	Assembly Lot Number

System Serial ID Register 0

Name: SYSSER0

Address: 0xFFFF0238

Default Value: 0x00000000 (updated by kernel at power-on)

Access: Read/write

Function: At power-on, this 32-bit register holds the value of the original manufacturing lot number from which this specific ADuC7034 unit was manufactured (bottom die only). Used in conjunction with SYSSER1, this lot number allows the full manufacturing history of this part to be traced (bottom die only).

Table 97. SYSSER0 MMR Bit Designations

Bit	Description
31 to 27	Wafer Number. The five bits read from this location give the wafer number (1 to 24) from the wafer fabrication lot ID (from which this device originated). When used in conjunction with SYSSER0[26:0], it provides individual wafer traceability.
26 to 22	Wafer Lot Fabrication Plant. The five bits read from this location reflect the manufacturing plant associated with this wafer lot. When it is used in conjunction with SYSSER0[21:0], it provides wafer lot traceability.
21 to 16	Wafer Lot Fabrication ID. The six bits read from this location form part of the wafer lot fabrication ID, and used in conjunction with SYSSER0[26:22] and SYSSER0[15:0], provides wafer lot traceability.
15 to 0	Wafer Lot Fabrication ID. These 16 LSBs hold a 16-bit number to be interpreted as the wafer fabrication lot ID number. When used in conjunction with the value in SYSSER1, that is, the manufacturing lot ID, this number is a unique identifier for the part.

System Serial ID Register 1

Name: SYSSER1

Address: 0xFFFF023C

Default Value: 0x00000000 (updated by kernel at power-on)

Access: Read/write

Function: At power-on, this 32-bit register holds the values of the part ID number, silicon mask revision number, and kernel revision number (bottom die only) as detailed in Table 98.

Table 98. SYSSER1 MMR Bit Designations

Bit	Description
31 to 28	Silicon Mask Revision ID. The 4 bits read from this nibble reflect the silicon mask ID number. Specifically, the hex value in this nibble should be decoded as the lower hex nibble in the hex numbers reflecting the ASCII characters in the range of A to O. Examples follow:

Bit	Description
	<p>Bits[19:16] = 0001 = 0x1, therefore, this value should be interpreted as 41 which is ASCII Character A corresponding to Silicon Mask Revision A.</p> <p>Bits[19:16] = 1011 = 0xB, therefore the number is interpreted as 4B which is ASCII Character K corresponding to Silicon Mask Revision K.</p> <p>The allowable range for this value is 1 to 15 which is interpreted as 41 to 4F or ASCII Character A to Character O.</p>
27 to 20	Kernel Revision ID. This byte contains the hex number, which should be interpreted as an ASCII character indicating the revision of the kernel firmware embedded in the on-chip Flash/EE memory. Example: reading 0x41 from this byte should be interpreted as A indicating a Revision A kernel is on-chip.
19 to 16	Reserved. For prerelease samples, these bits refer to the kernel minor revision number of the device.
15 to 0	Part ID. These 16 LSBs hold a 16-bit number that are interpreted as the part ID number. When used in conjunction with the value in SYSSER0, that is, the manufacturing lot ID, this number is a unique identifier for the part.

System Assembly Lot ID

Name:	SYSALI
Address:	0xFFFF0560
Default Value:	0x00000000 (updated by kernel at power-on)
Access:	Read/write
Function:	At power-on, this 32-bit register holds the lower half of the assembly lot ID.

System Kernel Checksum

Name:	SYSCHK
Address:	0xFFFF0240
Default Value:	0x00000000 (updated by kernel at power-on)
Access:	Read/write
Function:	At power-on, this 32-bit register holds the kernel checksum

System Identification FEE0ADR

- Name:** FEE0ADR
- Address:** 0xFFFF0E10
- Default Value:** Non zero
- Access:** Read/write
- Function:** This 16-bit register dictates the address upon which any Flash/EE command executed via FEE0CON acts.
- Note:** This MMR is also used to identify ADuC7034 family member and prerelease silicon revision.

Table 99. FEE0ADR System Identification MMR Bit Designations

Bit	Description
15 to 4	Reserved
3 to 0	ADuC703x Family ID 0x0 = ADuC7030 0x2 = ADuC7032 0x3 = ADuC7033 0x4 = ADuC7034 0x6 = ADuC7036 Others = reserved for future use

SCHEMATIC

This example schematic represents a basic functional circuit implementation. Additional components need to be added to ensure the system meets any EMC and other overvoltage/overcurrent compliance requirements.

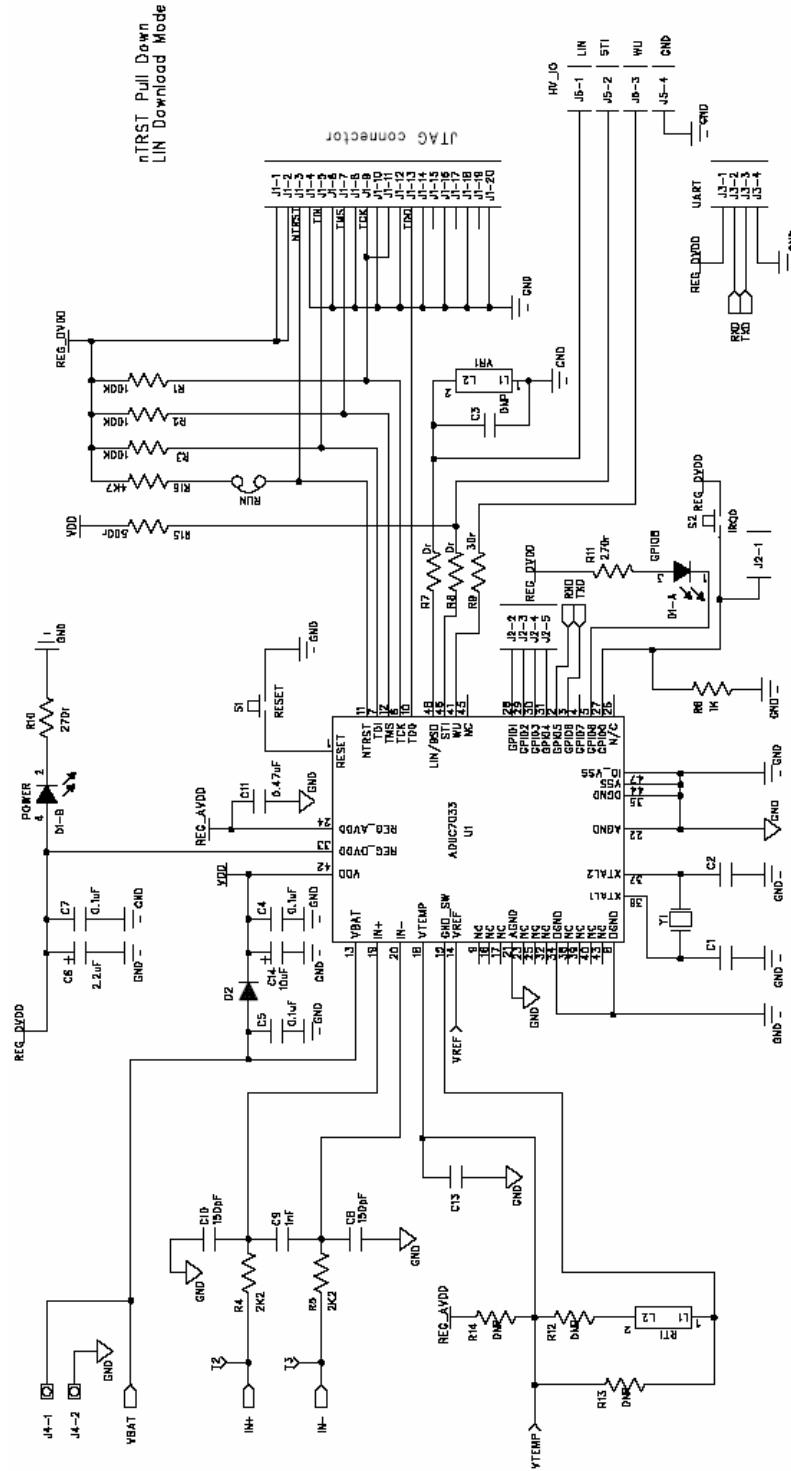
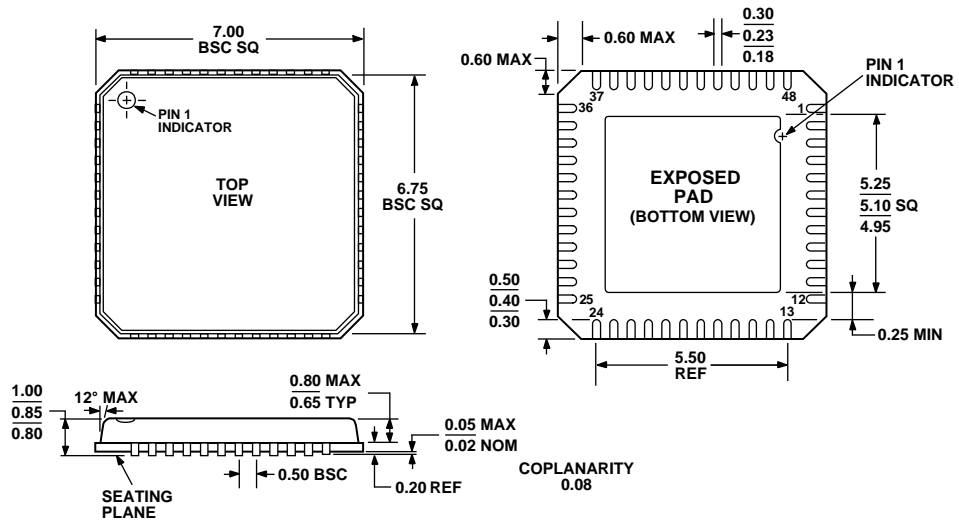

Figure 57. Schematic

OUTLINE DIMENSIONS



COMPLIANT TO JEDEC STANDARDS MO-220-VKGD-2
 Figure 58. 48-Lead Lead Frame Chip Scale Package [LFCSQ_VQ]
 7 mm × 7 mm Body, Very Thin Quad
 (CP-48-1)
 Dimensions shown in millimeters

ORDERING GUIDE

Model	Temperature Range	Package Description	Package Option

NOTES

NOTES

NOTES