

ADSP-2141L

APPLICATIONS

Security Coprocessor for High Speed Networking Products (Routers, Switches, Hubs)
 Cryptographic Core for Firewalls, Hardware Encryptors, and More
 Crypto Peripheral for Implementing Secure NIC Adapters (10/100 Ethernet, Token Ring, ISDN)
 Secure Modem-on-a-Chip (V.34, ADSL)

FEATURES

DES CRYPTO BLOCK

640 Mbps Sustained Performance—Single DES
 214 Mbps Sustained Performance—Triple DES
 Supports All Modes: ECB; CBC; 64-Bit OFB; and 1-, 8-, 64-Bit CFB. Includes Automatic Padding
 Implements IPsec ESP Transforms Autonomously at OC-3 (155 Mbps) Rates (3-DES, SHA-1)

HASH BLOCK

Hardware-Based SHA-1 and MD-5 Hashing
 253 Mbps Sustained Performance—SHA-1
 315 Mbps Sustained Performance—MD-5
 Implements IPsec AH and HMAC Transforms

SECURE KERNEL CONTROL

Tamper-Resistant Isolation of Cryptographic Functions Enforces Security Perimeter Around Crypto Functions and Crypto Storage Locations
 Anticlone Protection
 Secure Algorithm Download

SafeNet CGX LIBRARY

On-Chip SafeNet CGX Crypto Library with Flexible CGX API
 Includes *Chained* and *Parallel Execution* Commands Such as Hash-and-Encrypt
 Embodied as 32K Words (32K × 24) Kernel Program Mask-Programmed into On-Chip ROM
 On-Chip Protected 4K × 16 Security Scratchpad RAM

RANDOM NUMBER GENERATOR

Hardware-Based Nondeterministic Random Number Generator
 Generates Internal Session Keys That Are Never Exposed Outside of the SafeNet DSP
 Redundant Fail-Safe Design
 Up to 1.3 Mbits of Random Data Available per Second

FUNCTIONAL BLOCK DIAGRAM

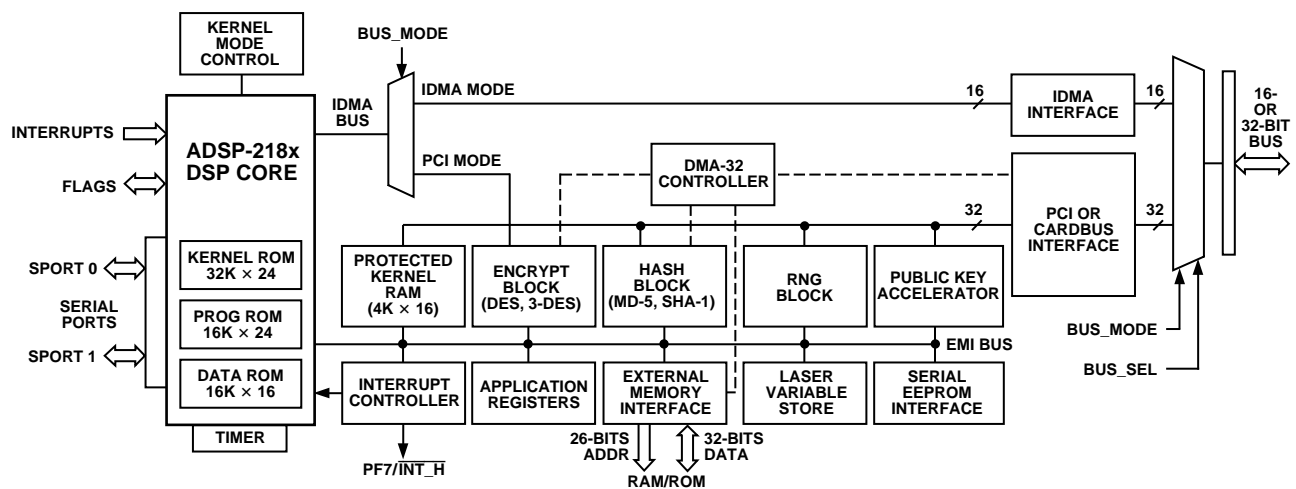

SafeNet is a registered trademark of Information Resource Engineering (IRE).

REV. 0

Information furnished by Analog Devices is believed to be accurate and reliable. However, no responsibility is assumed by Analog Devices for its use, nor for any infringements of patents or other rights of third parties which may result from its use. No license is granted by implication or otherwise under any patent or patent rights of Analog Devices.

One Technology Way, P.O. Box 9106, Norwood, MA 02062-9106, U.S.A.
 Tel: 781/329-4700 World Wide Web Site: <http://www.analog.com>
 Fax: 781/326-8703 © Analog Devices, Inc., 2000

ADSP-2141L

PUBLIC KEY ACCELERATOR

Accelerator for Math-Intensive Public Key Operations
Diffie-Hellman Negotiate: <29 ms (1024-Bit Modulus, 180-Bit Exponent)

RSA 1024-Bit Sign: <29 ms; RSA 1024-Bit Verify: 6 ms
DSA Sign: <39 ms; DSA Verify: <66 ms

KEY MANAGEMENT BLOCK

Laser-Programmed Unique Triple-DES Cryptovariable
Protects Off-Chip Storage

Support for Secure Storage of Both Secret Keys and
Public/Private Key Pairs

Trust-Model Rules Enforcement

Only Encrypted Keys May Be Exported Off the Chip
Internal Key Cache for 15 Keys—Can Be Expanded to
700 Keys On-Chip

Keys May Also Be Securely Stored Off-Chip, Allowing
Unlimited Storage

DSP CORE

40 MIPS Sustained Performance

Single-Cycle Instruction Execution

Single-Cycle Context Switch

Zero-Overhead Looping

Low Power Dissipation

16K Words (16K × 24) On-Chip Program RAM

16K Words (16K × 16) On-Chip Data RAM

64M Words Off-Chip Program and Data Memory

Programmable 16-Bit Interval Timer with Prescale

PCI BUS/CARDBUS INTERFACE

32-Bit 3.3 V Bus Interface

33 MHz or 40 MHz* Bus Speed

Bus Master and Target Modes

Can Directly DMA Between Crypto Functions and Other
PCI Bus Agents

*66 MHz speed pending chip characterization.

GENERAL DESCRIPTION

The ADSP-2141L SafeNet DSP is a highly integrated embedded security processor that incorporates a sophisticated, general purpose DSP, along with a number of high performance Cryptographic function blocks, as well as PCI, DMA and Serial EEPROM interfaces. It is fabricated in 0.35 μ CMOS triple-layer metal technology and uses a 3.3 V power supply. It is available in a 208-lead MQFP package with a commercial (0°C to 70°C) temperature range.

DSP Core

The DSP is a standard Analog Devices ADSP-218x core with full ADSP-2100 family compatibility. The ADSP-218x Core combines the base DSP components from the ADSP-2100 family with the addition of two serial ports, a 16-bit internal DMA port, a byte DMA port, a programmable timer, Flag I/O, extensive interrupt capabilities, and on-chip program and data memory. The external memory interface of the 218x core has been extended to support up to 64M-words addressing for both program and data memory. Some core enhancements have been added in the ADSP-2141L, including on-chip security ROM and interrupt functions. Refer to the Analog Devices ADSP-2183 data sheet for further information.

SafeNet CGX Library—Secure Kernel

The SafeNet CGX Library is a crypto library embodied as firmware (a secure kernel) that is mask-programmed into ROM within the DSP. This solution protects the library from tampering. The CGX Library provides the Application Programming Interface (API) to applications that require security services from the ADSP-2141L. Those applications may be software executing in user mode on the DSP, or they may be external host software accessing the ADSP-2141L via a PCI bus. Approximately 40 Crypto commands—called CGX (CryptoGraphic eXtensions)—are provided at the API and a simple control block structure is used to pass arguments into the secure kernel and return status. The CGX library includes integrated drivers for the various hardware crypto blocks on the chip. This allows the programmer to ignore those details and concentrate on other product design issues.

The CGX library firmware runs under a protected mode state of the DSP as described in the Kernel Mode Control section following. This guarantees the security integrity of the system during the execution of CGX processes and, for example, prevents disclosure of cryptographic key data or tampering with a security operation.

Kernel Mode Control

The Kernel Mode Control subsystem is responsible for enforcing the security perimeter around the cryptographic functions of the ADSP-2141L. The device may operate in either user mode (kernel space is not accessible) or kernel mode (kernel space is accessible) at a given time. When in kernel mode, the kernel RAM and certain protected crypto registers and functions (kernel space) are accessible only to the CGX library firmware. The CGX Library executes host-requested macro-level functions and then returns control to the calling application. The kernel mode control subsystem resets the DSP should any security violation occur, such as attempting to access a protected memory location while in user mode.

Protected Kernel RAM

The $4K \times 16$ kernel RAM provides a secure storage area on the ADSP-2141L for sensitive data such as keys or intermediate calculations during public key operations. The Kernel Mode Control subsystem (above) enforces the protection by allowing only internal secure kernel mode access to this RAM. A public keyset and a cache of up to 15 secret keys may be stored in kernel RAM. Secure key storage may be expanded to 700 secret keys by assigning segments of the DSP's internal data RAM to be protected. Furthermore, a virtually unlimited number of data encryption keys may be stored in an encrypted form in off-chip memory.

Encrypt Block

The encrypt block performs high speed DES and Triple-DES encrypt/decrypt operations. All four standard modes of DES are supported: Electronic Code Book (ECB), Cipher Block Chaining (CBC), 64-bit Output Feedback (OFB) and 1-bit, 8-bit and 64-bit Cipher Feedback (CFB). The DES encrypt/decrypt operations are highly pipelined and execute full 16-round DES in only four clock cycles. Hardware support for padding insertion, verification and removal further accelerates the encryption operation. Context switching is provided to minimize the overhead of changing crypto keys and Initialization Vectors (IVs) to nearly zero.

Hash Block

The secure hash block is tightly coupled with the encrypt block and provides hardware accelerated one-way hash functions. Both the MD-5 and SHA-1 algorithms are supported. Combined operations that chain both hashing and encrypt/decrypt functions are provided in order to significantly reduce the processing time for data that needs both operations applied. For *hash-then-encrypt* and *hash-then-decrypt* operations, the ADSP-2141L can perform parallel execution of both functions from the same source and destination buffers. For *encrypt-then-hash* and *decrypt-then-hash* operations, the processing must be sequential, but minimum latency is still provided through the pipeline chaining design. An offset may be specified between the start of hashing and the start of encryption to support certain protocols such as IPsec. A 'mutable bit handler' is also provided on the hash engine to facilitate IPsec AH processing.

Random Number Generator (RNG) Block

The hardware random number generator provides a true, non-deterministic noise source for the purpose of generating keys, Initialization Vectors (IVs), and other random number requirements. Random numbers are provided as 16-bit words to the kernel. The CGX kernel requests random numbers as needed to perform requested CGX commands such as CGX_Gen_Key, and can also directly supply from 1 to 65,535 random bytes to a host application via the CGX_Random command.

Public Key Accelerator

The public key accelerator module works in concert with the CGX kernel firmware to provide full public key services to the host application. The kernel provides macro-level functions to perform Diffie-Hellman key agreement, RSA encrypt or decrypt, DSA compute and verify digital signatures. The hardware accelerator block speeds computation-intensive operations such as large vector multiply, add, subtract, square.

PCI/Cardbus Interface

A full 40 MHz/33 MHz PCI bus interface has been added to the core DSP functions. The 32-bit PCI interface supports both bus master and target modes. The ADSP-2141L is capable of using DMA to directly access data on other PCI entities and pass that data through its encryption/hash engines.

32-Bit DMA Controller

The ADSP-2141L incorporates a high performance 32-bit DMA controller which can be set up to move data efficiently between Host PCI memory, the hash/encrypt blocks, and/or external memory. The DMA controller can be used with the PCI bus in master mode, thus autonomously moving 32-bit data with minimal DSP intervention. Up to 255 long words (1020 bytes) can be moved in a burst at up to 160 Mbytes per second.

Application Registers

The application registers are a set of memory-mapped registers that facilitate communications between the ADSP-2141L and a host processor via the PCI bus. One of the registers is a mailbox that is 44 bytes long and set up to hold the CGX command structure passed between the host and DSP processors. The application registers also provide the mechanism that allows the DSP and the external host to negotiate ownership of the hash/encrypt block.

Serial EEPROM Interface

The serial EEPROM interface allows an external nonvolatile memory to be connected to the ADSP-2141L for storing PCI configuration information (Plug and Play), as well as general-purpose nonvolatile storage. For example, encrypted (black) keys could be stored into EEPROM for fast recovery after a power outage.

Interrupt Controller

The DSP core provides support for 14 interrupt sources, including six external and eight internal. All interrupts are prioritized into 12 levels and interrupt nesting may be enabled or disabled under software control. The security block interrupt controller provides enhancements to the DSP interrupt functions.

Primarily, the interrupt controller provides a new interrupt generation capability to the DSP or to an external host processor. Under programmable configuration control, a crypto interrupt may be generated due to completion of certain operations such as encrypt complete, hash complete. The interrupt may either be directed at the DSP core (on $\overline{\text{IRQ2}}$), or provided on an output line (PF7/ $\overline{\text{INT_H}}$) to a host subsystem.

Laser Variable Storage

The laser variable storage consists of 256 bits of tamper-proof factory-programmed data that is only accessible to the internal function blocks and the security kernel. Included in these laser variable bits are:

- Local Storage Variable (master key-encryption key)
- Randomizer Seed (to supplement the true entropy fed into the RNG)
- Program Control Data (enables/disables various features and configures the ADSP-2141L)
- CRC of the Laser Data (to verify laser data integrity).

ADSP-2141L

The Program Control Data Bits (PCDBs) include configuration for permitted key lengths, algorithm enables, Red KEK loading. Most of the PCDB settings may be overridden with a digitally signed token which may be loaded into the ADSP-2141L when it boots. These tokens are created by IRE and each is targeted to a specific ADSP-2141L using a hash of its unique identity.

Downloadable Secure Code

The ADSP-2141L allows additional security functions to be added to the device through a secure download feature. Up to 16K words of code may be downloaded into internal memory within the DSP and this code can be given the security privileges of the CGX kernel firmware. All downloaded firmware is authenticated with a digital signature and verified with an on-chip public key. Additional functions could include new encryption, hash or public key algorithms such as IDEA, RC-4, RIPEMD, elliptic curve, or any other application that needs direct control over the protected cryptographic hardware.

ARCHITECTURE OVERVIEW

This section provides an architecture-level description of the unique function blocks within the ADSP-2141L.

Memory Map

The ADSP-2141L memory map is very similar to that of the ADSP-2183 DSP, except that it includes significantly more off-chip memory addressing, and has additional crypto registers which are accessible to the user.

DSP Core

The DSP core is architecturally identical to the ADSP-218x with a few exceptions.

- The memory map includes additional external memory addressing through the PMOVLAY and DMOVLAY mechanisms. For more information, see the Memory Map section.
- Additional memory-mapped crypto registers are available in the kernel data RAM space.
- The PF7/INT_H flag pin may be reassigned to be the host interrupt output.

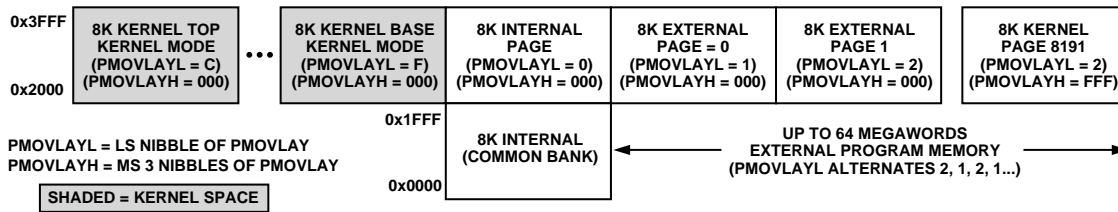

Figure 1. Program Memory (MMAP = 0)

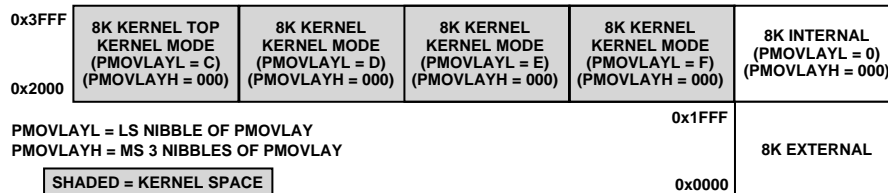

Figure 2. Program Memory (MMAP = 1)

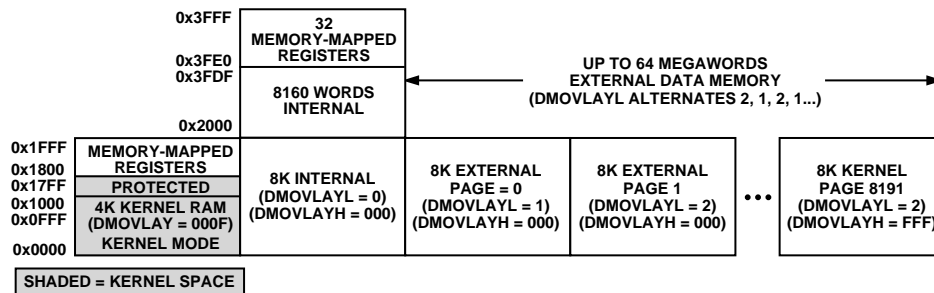

Figure 3. Data Memory

ADSP-2141L

Context switching is optimized to minimize the overhead of changing cryptographic keys to near zero.

The software interface to the module consists of a set of memory-mapped registers, all of which are visible to the DSP and most of which can be enabled for host access via the PCI bus. A set of five, 16-bit registers define the operation to be performed, the length of the data buffer to be processed, in bytes, the offset between the start of hashing and encryption (or vice versa), and the padding operation. If the data length is unknown at the time the encrypt/decrypt operation is started, the data length register may be set to zero, which specifies special handling. In this case, data may be passed to the hash/encrypt block indefinitely until the end of data is encountered. At that time, the operation is terminated by writing a new control word to the hash/encrypt control register (either to process the next packet or to invoke the idle state if there is no further work to do). This will close out the processing for the packet, including the addition of the selected crypto padding.

A set of seven status registers provides information on when a new operation can be started, when there is space available to accept new data, when there is data available to be read out, and the results from the padding operation.

Crypto Contexts

There are two sets of *crypto-context* registers. Each context contains a DES or triple DES key, initialization vector, and precomputed hashes (inner and outer) of the authentication key for HMAC operations. The contexts also contain registers to reload the byte count from a previous operation (which is part of the hashing context), as well as an IV (also called *salt*) for decrypting a black key, if necessary.

Once a crypto-context has been loaded and the operation defined, data is processed by writing it to a data input FIFO. At the I/O interface, data is always written to, or read from, the same address. Internally, the hash and encryption functions have separate 512-bit FIFOs, each with their own FIFO management pointers. Incoming data is automatically routed to one or both of these FIFOs, depending on the operation in progress. Output from the encryption block is read from the data output FIFO. In encrypt-hash or decrypt-hash operations, the data is also automatically passed to the hashing data input FIFO. Output from the hash function is always read from the digest register of the appropriate crypto-context.

The initialization vector to be used for a crypto operation can be loaded as part of a crypto-context. When an operation is complete, the same context will contain the resulting IV produced at the end, which can be saved away and restored later to continue the operation with more data.

In certain packet-based applications such as IPsec, a feature is available that avoids the need for the control software to generate and load random IVs for outgoing (encrypted) packets. Effectively, the IV register can be configured to be automatically updated with new random numbers for each encrypted packet, with almost no software intervention.

Padding

When the input data is not a multiple of eight bytes (a 64-bit DES block), the encrypt module can be configured to automatically append pad bytes. There are several options for how the padding is constructed, which are specified using the pad control word of the operation description. Options include zero padding, pad-length character padding (PKCS#7), incrementing count,

with trailing pad length and next header byte (for IPsec), or fixed character padding. Note that for the IPsec and PKCS#7 pad protocols, there are cases where the padding not only fills out the last 8-byte block, but also causes an additional 8-byte block of padding to be added.

For the hash operations, padding is automatically added as specified in the MD-5 and SHA-1 standards. When the hash final command is issued indicating the last of the input data, the algorithm-specified padding and data count bits are added to the end of the hash input buffer prior to computing the hash.

Data Offsets

Certain security protocols, including IPsec, require portions of a data packet to be hashed while the remainder of the data is both hashed and encrypted. The ADSP-2141L supports this requirement through the OFFSET register, which allows specifying the number of 32-bit dwords of offset between the hash and encrypt/decrypt operations.

Black Key Loads

The cryptographic keys loaded as part of a crypto-context can be stored off-chip in a *black*, or encrypted, form. If the appropriate control bit is set (HECNTL Bit 15), the DES or 3-DES key will be decrypted immediately after it is written into the context register. The hardware handles this decryption automatically. The Key Encryption Key (KEK) that covers the black keys is loaded in a dedicated write-only KEK register within the ADSP-2141L. The IV for decrypting the black secret key is called 'salt' and must be stored along with the black key (as part of the context). Note that 3-DES CBC mode is used for protecting 3-DES black keys and single DES CBC is used for single DES black keys.

When black keys are used, the key-decrypt operation adds a 6-cycle overhead (0.15 μ s @ 40 MHz) for DES keys or 36-cycle overhead (0.9 μ s @ 40 MHz) for triple DES keys each time a new crypto-context is loaded. (Note that if the same context is used for more than one packet operation, the key decryption does not need to be performed again.) Depending on the sequencing of operations, this key decryption may in fact be hidden (from a performance impact perspective) if other operations are underway. This is because the black key decryption process only requires that the DES hardware be available. For example, if the DSP is reading the previous hash result from the output FIFO, the black key decryption can be going on in parallel. Also note that the data driver firmware does NOT have to wait for the key to be decrypted before writing data to the input FIFO. The hardware automatically waits for the key to be decrypted before beginning to process data for a given packet. So, with efficient pipeline programming, it is possible to make the impact of black key essentially zero.

The KEK for key decryption is loaded via the secure kernel firmware using one of the CGX key manipulation commands. (For more information, see the Command Summary section.) This KEK is typically the same for all black keys, since it is usually protecting local storage only. It is designated the DKEK in the CGX API.

One of the laser-programmed configuration bits specifies whether red (plaintext) keys are allowed to be loaded into the ADSP-2141L from a host. If the *AllowRedKeyLoad* laser bit is not set, keys may only be loaded in their *black* form. This is useful in systems where export restrictions limit the key length that may be used or where the external storage environment is untrusted.

If the AllowRedKeyLoad bit is set, keys may be loaded either in their black form, or in the *red* or unencrypted form. Note that the laser configuration bit may be overridden with a signed enabler token. (For more information, see the Laser Variable Storage section.)

Depending on the definition of the security module boundary in a given application, FIPS 140-1 may require the use of black keys to protect key material. In other words, if the security boundary does not enclose the database where keys are stored, those keys must be protected from compromise. Black key is a satisfactory way to meet this FIPS requirement.

Random Number Generator (RNG) Block

The random number generator is designed to provide highly random, nondeterministic binary numbers at a high delivery rate with little software intervention. The random numbers are accessible to the kernel firmware in a 16-bit register that may be read by the DSP in kernel mode. Once the register is read, the RNG immediately generates a new 16-bit value that is available within 12 microseconds.

All application-level access to random numbers should occur through the Kernels CGX_RANDOM command (see the Command Summary section).

The random number generator is designed using a “shot noise” true entropy source which is sampled by the master 40 MHz clock of the ADSP-2141L. The entropy source then feeds a complex nonlinear combinatorial circuit that produces the final RNG output based on the interaction of the entropy source and the 40 MHz system clock. Over 200 stages of Linear Feedback Shift Register (LFSR) are incorporated into the RNG design.

In order to facilitate FIPS 140-1 compliance, an option may be selected during CGX kernel initialization to enable an ANSI X9.17 Annex C post-randomizer to be applied to the output of the RNG. This randomizer applies the DES ECB algorithm multiple times to further disperse and whiten the random source. Although this is not necessary to ensure the quality of the random numbers, it meets the criteria for a NIST-approved random number generation algorithm.

Public Key Accelerator (PKAC)

The public key arithmetic coprocessor (otherwise known as a *BigNum* processor) is designed to support long vector calculations of the kind needed to perform RSA, Diffie-Hellman and Elliptic Curve operations.

The PKAC can perform multiplication, squaring, addition and subtraction on arbitrary length bit vectors. The CGX software is responsible for setting the address register for the operands and

result, as well as specifying the length and operation type. Once the operation type field is written, the processor polls the operation complete status while the calculation is carried out.

The PKAC utilizes the protected kernel RAM for input, output and intermediate variable storage. It may only be accessed from the secure kernel mode. Since public key computations typically take many milliseconds to complete, they may be preempted using a DSP interrupt.

Most application interaction with the public key accelerator will occur via the CGX software interface (see the Command Interface section). Both high level public key operations such as RSA Sign or Create Diffie-Hellman Key, as well as primitive operations such as Multiply Vector, Add Long Vector, etc., are presented via the CGX interface.

PCI/Cardbus Interface

The ADSP-2141L appears as a target on the PCI Bus as a single contiguous memory space of 128k bytes. In this memory space, the host can access the following:

- The unprotected internal crypto registers of the ADSP-2141L
- IDMA access to the DSP’s internal program memory (PM) and data memory (DM)
- Paged access to external memory connected to the ADSP-2141L
- The Kernel RAM (KRAM) if it has been unprotected by an extended mode program

As a PCI Master, the ADSP-2141L can transfer data between:

- The unprotected internal crypto registers and FIFOs of the ADSP-2141L and PCI Host memory
- External memory and PCI Host memory

A 32-bit DMA engine within the ADSP-2141L facilitates these transfers and permits full PCI bandwidth use.

Serial EEPROM Interface

The serial EEPROM interface allows the ADSP-2141L to automatically read the PCI configuration parameters at chip power-up. IRE can provide the data content for the EEPROM to properly set the chip device vendor ID, type and properties for full compliance with the PCI Plug and Play standards.

In addition to being used for storage of host bus parameters, any extra space in the EEPROM may be accessed by the DSP, either in user mode or kernel mode. Support for this function is not included in the standard CGX command set. Refer to the *ADSP-2141 User’s Manual* for the information on the data contents of the EEPROM. Refer to <http://www.analog.com/industry/dsp/ire.html>.

Table I. Interrupt Sources

Internal Interrupt Sources		External Interrupt Sources	
Interrupt	Notes	Interrupt	Notes
Reset	or Power-Up (PUCR = 1)	$\overline{\text{IRQ2}}$	Edge- or Level-Sensitive
Power-Down		$\overline{\text{IRQL1}}$	Level-Sensitive
SPORT0 Transmit		$\overline{\text{IRQLO}}$	Level-Sensitive
SPORT0 Receive		$\overline{\text{IRQE}}$	Edge-Sensitive
BDMA Interrupt		IRQ1	Edge- or Level-Sensitive
SPORT1 Transmit	Mixed with IRQ0	IRQ0	Edge- or Level-Sensitive
SPORT1 Receive			
Timer			

ADSP-2141L

Interrupt Controller

The DSP core of the ADSP-2141L provides a powerful set of interrupt sources. A total of 14 interrupt sources are available, although two pairs are multiplexed, yielding 12 simultaneous sources. Refer to Table I.

The ADSP-2141L enhances the existing interrupt controller within the ADSP-218x DSP Core with some additional functions related to the crypto functional blocks and the external host bus interfaces. Two additional interrupt controller subsystems have been added to the basic interrupt controller as shown in Figure 5.

The DSP interrupt controller allows programming between one and nine sources for the IRQ2 interrupt to the DSP. The DIMASK register provides the mask to select which interrupt source is enabled. A pair of status registers, DUMSTAT and DMSTAT, allow the DSP firmware to read the status of any interrupt source either before or after the mask is applied.

The host interrupt controller allows programming between one and five sources for the PF7/INT_H interrupt output signal (which may be connected to the interrupt input of the host system). The HMASK register provides the mask to select which interrupt source is enabled. A pair of status registers, HUMSTAT and HMSTAT, allow the host firmware to read the status of any interrupt source either before or after the mask is applied.

Laser Variable Storage

The laser variables are configured through 256 Fuses in the ADSP-2141L, which are programmed during IC manufacture. Each ADSP-2141L produced is programmed with a unique set of Laser Variables.

- Local Storage Variable (LSV—the Master Key-Encryption-Key)
- Internal Seed Variable

- 48-Bit Program Control Data (enables/disables various features and configures the ADSP-2141L)
- CRC of the Laser Data (to verify integrity of the laser bits)

The LSV is a unique triple DES master key-encrypting key that allows the ADSP-2141L to securely store data (primarily other keys) off-chip for later reloading. This is necessary if more storage space is needed than is available with on-chip RAM, or if keys need to be saved and restored after a power outage. Each ADSP-2141L produced is programmed with a unique, randomly generated local storage variable.

The internal seed variable is used to randomly initialize the RNG circuits before the entropy is mixed in. Each ADSP-2141L produced is programmed with a unique, randomly generated internal seed variable which is loaded into the RNG at chip boot time and cannot ever be read by software.

The 48 Program Control Data Bits (PCDBs) include configuration for permitted key lengths, algorithm enables, red KEK loading, internal IC pulse timing characteristics. The PCDBs provide configuration data that falls into three categories:

- Internal IC pulse-timing characteristics
- ADSP-2141L hardware version number field
- ADSP-2141L feature enables

The first two categories consist of data that cannot be altered once the ADSP-2141L has been fabricated.

The feature enables can be overridden using a factory token enabler which may be passed to the CGX kernel as part of the CGX_INIT command. This token is digitally signed with an IRE private key and verified internal to the ADSP-2141L with its public key. The CGX_INIT command is documented in the *ADSP-2141 CGX Interface Programmer's Guide* (available from <http://www.ire-ma.com/proddoc.htm>).

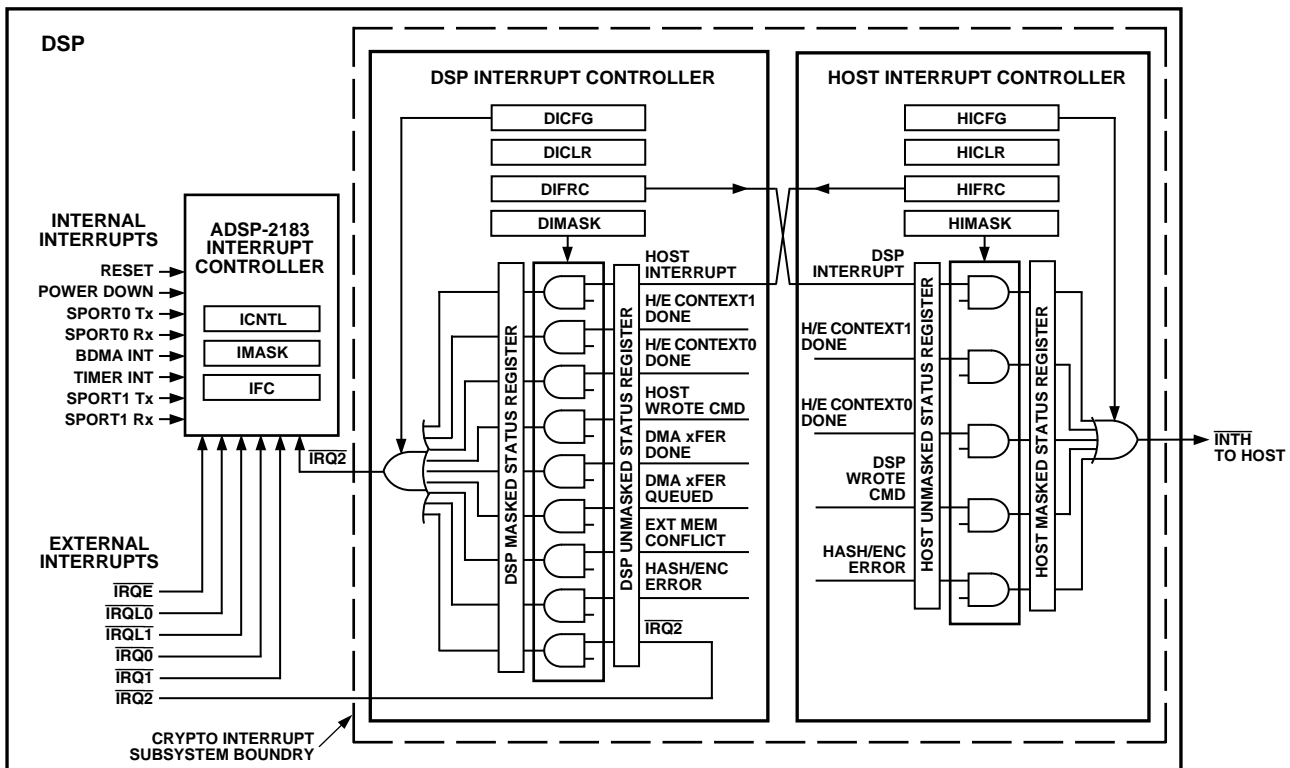

Figure 5. Interrupt Controller Block Diagram

PIN FUNCTIONS

I/O Descriptions

This section describes the physical I/O hardware on the ADSP-2141L.

PIN FUNCTION DESCRIPTIONS—I/O Hardware

Pin Name	# of Pins	Input/Output	Function
External Memory Bus Address [25:0]	26	O	Address Output Pins for Program, Data, Byte and I/O Spaces (13 Bits 2183, 13 Bits from Overlay Register) Note: A0 not used for 32-bit memory.
Data [31:0]	32	I/O	Data I/O Pins for Program and Data Memory Spaces D31:0 are used for wide-bus data memory. D23:0 are used for DSP Program RAM. D23:8 are used for I/O Space. D23:8 are used for DSP Data RAM. D15:8 are used for byte memory. <i>D23:16 are also used as Byte Space Addresses</i>
Interrupts			
<u>IRQ2</u>	1	I	Edge- or Level-Sensitive Interrupt Request
<u>IRQL0</u>	1	I	Level-Sensitive Interrupt Requests
<u>IRQL1</u>	1	I	Level-Sensitive Interrupt Requests
<u>IRQE</u>	1	I	Edge-Sensitive Interrupt Request
Bus Signals			
<u>BR</u>	1	I	Bus Request Input
<u>BG</u>	1	O	Bus Grant Output
<u>BGH</u>	1	O	Bus Grant Hung Output
<u>PMS</u>	1	O	Program Memory Select Output
<u>DMSL</u>	1	O	Data Memory Select Output (Lower 16 Bits for 32-Bit DM)
<u>DMSH</u>	1	O	Upper Memory Select Output (Upper 16 Bits for 32-Bit DM, Not Used for 16-Bit DM)
<u>BMS</u>	1	O	Byte Memory Select Output
<u>IOMS</u>	1	O	I/O Space Memory Select Output
<u>CMS</u>	1	O	Combined Memory Select Output (<u>PMS</u> , <u>DMS*</u> , <u>IOMS</u> , <u>BMS</u>)
<u>RD</u>	1	O	Memory Read Enable Output
<u>WR</u>	1	O	Memory Write Enable Output
Miscellaneous			
MMAP	1	I	Memory Map Select Input (1 = Overlay External at 0x0000)
BMODE	1	I	Boot Option Control Input (0 = BDMA, 1 = IDMA)
CLKIN, XTAL	2	I	Clock or Quartz Crystal Input (1/2 of the ADSP-2141 Clock)
CLKOUT	1	O	Processor Clock Output
Serial Ports			
SPORT0			
SCLK0	1	I/O	Serial Port 0 Clock
DR0	1	I	Serial Port 0 Receive Data Input
RFS0	1	I/O	Serial Port 0 Receive Frame Sync
DT0	1	O	Serial Port 0 Transmit Data Output
TFS0	1	I/O	Serial Port 0 Transmit Frame Sync
SPORT1			
<i>Port Configuration</i> <i>(System Control Reg) -></i>			
SCLK1	1	I/O	Serial Port 1 Clock
DR1	1	I	Serial Port 1 Receive Data Input
RFS1	1	I/O	Serial Port 1 Receive Frame Sync
DT1	1	O	Serial Port 1 Transmit Data Output
TFS1	1	I/O	Serial Port 1 Transmit Frame Sync
Power-Down			
<u>PWD</u>	1	I	Power-Down Initiate Control
<u>PWDACK</u>	1	O	Power-Down Acknowledge

ADSP-2141L

Pin Name	# of Pins	Input/Output	Function
Flags			
PF6:0	7	I/O	Programmable I/O Pins
PF7/INT_H	1	I/O	Programmable I/O Pin-or-Interrupt Output (Host Mode)
Emulator			
\overline{EE}	1		(Emulator Only)
\overline{EBR}	1		(Emulator Only)
\overline{EBG}	1		(Emulator Only)
\overline{ERESET}	1		(Emulator Only)
\overline{EMS}	1		(Emulator Only)
\overline{EINT}	1		(Emulator Only)
ECLK	1		(Emulator Only)
ELIN	1		(Emulator Only)
ELOUT	1		(Emulator Only)
Serial EEPROM Interface			
EE_DI	1	O	Serial EEPROM Data In
EE_DO	1	I	Serial EEPROM Data Out
EE_CS	1	O	Serial EEPROM Chip Select
EE_SK	1	O	Serial EEPROM Clock
Bus Select			
BUS_MODE	1	I	Processor Bus Select
BUS_SEL	1	I	Bus Select
PCI Bus (Dedicated Pins)			
PCI_CLK	1	I	PCI Clock
PCI_PAR	1	I/O	PCI Parity Bit
PCI_IRDY	1	I/O	PCI Initiator Ready
PCI_STOP	1	I/O	PCI Abort Transfer

*When \overline{DMS} is enabled for generation of \overline{CMS} , the \overline{CMS} is activated for DSP access to external memory only, NOT for DMA controller accesses.

Bus Mode Descriptions

The Pin Function Descriptions, Bus Mode table, shows the multiplexed pins in 2183 and PCI mode. For more information on the PCI pins MPLX1–MPLX12, see the Pin Functions Description–PCI Mode Multiplex Bus table on the following page.

PIN FUNCTION DESCRIPTIONS—Bus Mode

Bus Mode	# of Pins	Input/Output	2183 Mode (bus_mode = 0, bus_sel = 0)	PCI Mode (bus_mode = 1, bus_sel = 0)
MPLX_RESET	1	I	RESET_1	Pci_rst
MPLX1	1	I/O		Pci_cbe3
MPLX2	1	I/O		Pci_cbe2
MPLX3	1	I/O		Pci_cbe1
MPLX4	1	I/O		Pci_cbe0
MPLX5	1	I	\overline{IRD}	Pci_idsel
MPLX6	1	I	\overline{IWR}	Pci_gnt
MPLX7	1	I/O	IS	Pci_frame
MPLX8	1	I/O	IAL	Pci_devsel
MPLX9	1	I/O	\overline{IACK}	Pci_trdy
MPLX10	1	I/O	FL0	Pci_perr
MPLX11	1	I/O	FL1	Pci_serr
MPLX12	1	O	FL2	Pci_req
MPLX_BUS[31:0]	32	I/O	IAD15:0 N/C 31:16	Pci_ad15:0 Pci_ad31:16
Power				
GND	24	–	Ground Pins	
VDD	22	–	Power Supply Pins (3.3 V)	
Total:	208		Includes the pins from this table and the I/O Hardware Pin Function Description table.	

IDMA Mode Multiplex Bus Pin Definition**IDMA Port (218x Mode)****PIN FUNCTION DESCRIPTIONS—IDMA Mode Multiplex Bus**

Pin Name	IDMA Name	Pins	I/O	Description
MPLX5	$\overline{\text{IRD}}$	1	I	IDMA Port Read Input
MPLX6	$\overline{\text{IWR}}$	1	I	IDMA Port Write Input
MPLX7	IS	1	I	IDMA Port Select
MPLX8	I $\overline{\text{AL}}$	1	I	IDMA Port Address Latch
MPLX9	$\overline{\text{IACK}}$	1	O	IDMA Port Access Ready Acknowledge
MPLX10	FL0	1	O	Output Flags
MPLX11	FL1	1	O	Output Flags
MPLX12	FL2	1	O	Output Flags
MPLX_BUS	IAD	16	I/O	IDMA Data I/O

PCI Port**PIN FUNCTION DESCRIPTIONS—PCI Mode Multiplex Bus**

Pin Name	PCI Name	Pins	I/O	Description
MPLX1	Pci_cbe3	1	I/O	Bus Command / Byte Enable 3
MPLX2	Pci_cbe2	1	I/O	Bus Command / Byte Enable 2
MPLX3	Pci_cbe1	1	I/O	Bus Command / Byte Enable 1
MPLX4	Pci_cbe0	1	I/O	Bus Command / Byte Enable 0
MPLX5	Pci_idsel	1	I	Initialization Device Select
MPLX6	Pci_gnt	1	I	Bus Grant
MPLX7	Pci_frame	1	I/O	Cycle Frame
MPLX8	Pci_devsel	1	I/O	Device Select
MPLX9	Pci_trdy	1	I/O	Target Ready
MPLX10	Pci_perr	1	I/O	Parity Error
MPLX11	Pci_serr	1	I/O	System Error
MPLX12	Pci_req	1	O	PCI Bus Request
MPLX_BUS	Pci_ad15:0			
	Pci_ad31:16	32	I/O	PCI Address/Data Bus
PF7/ $\overline{\text{INT_H}}$	Pci_intA	1	O	PCI Interrupt A Request

SYSTEM INTERFACE

The ADSP-2141L may be integrated into a wide variety of systems, including those that already have a microprocessor and those that will use the ADSP-2141L as the main processor. The device can be configured into one of two Host Bus modes: IDMA or PCI.

IDMA Bus Mode

The IDMA bus mode operates the same as in a native ADSP-218x device, as described in this section.

The IDMA port provides an efficient means of communication between a host system and the ADSP-2141L. The port is used to access the on-chip program memory and data memory of the DSP with only one DSP cycle per word overhead. The IDMA port cannot, however, be used to write to the DSP's memory-mapped control registers.

The IDMA port has a 16-bit multiplexed address and data bus, and supports reading or writing 16-bit data (DM) or 24-bit program memory (PM). The IDMA port is completely asynchronous and can be written to while the ADSP-2141L is operating at full speed.

The DSP memory address is latched and then automatically incremented after each IDMA transaction. An external device can therefore access a block of sequentially addressed memory by

specifying only the starting address of the block. This increases throughput as the address does not have to be sent for each memory access.

The IDMA port access occurs in two phases. The first is the IDMA address latch cycle. When the acknowledge is asserted, a 14-bit address and 1-bit destination type can be driven onto the bus by an external device. The address specifies an on-chip memory location; the destination type specifies whether it is a DM or PM access. The falling edge of the address latch signal latches this value to the IDMAA register.

Once the address is stored, data can either be read from or written to the ADSP-2141L's on-chip memory. Asserting the select line ($\overline{\text{IS}}$) and the appropriate read or write line ($\overline{\text{IRD}}$ and $\overline{\text{IWR}}$ respectively) signals the ADSP-2141L that a particular transaction is required. In either case, there is a one-processor-cycle delay for synchronization. The memory access consumes an additional processor cycle.

Once an access has occurred, the latched address is automatically incremented and another access can occur.

Through the IDMAA register, the ADSP-2141L can also specify the starting address and data format for DMA operation.

Figure 6 illustrates a typical system configuration for the IDMA mode.

ADSP-2141L

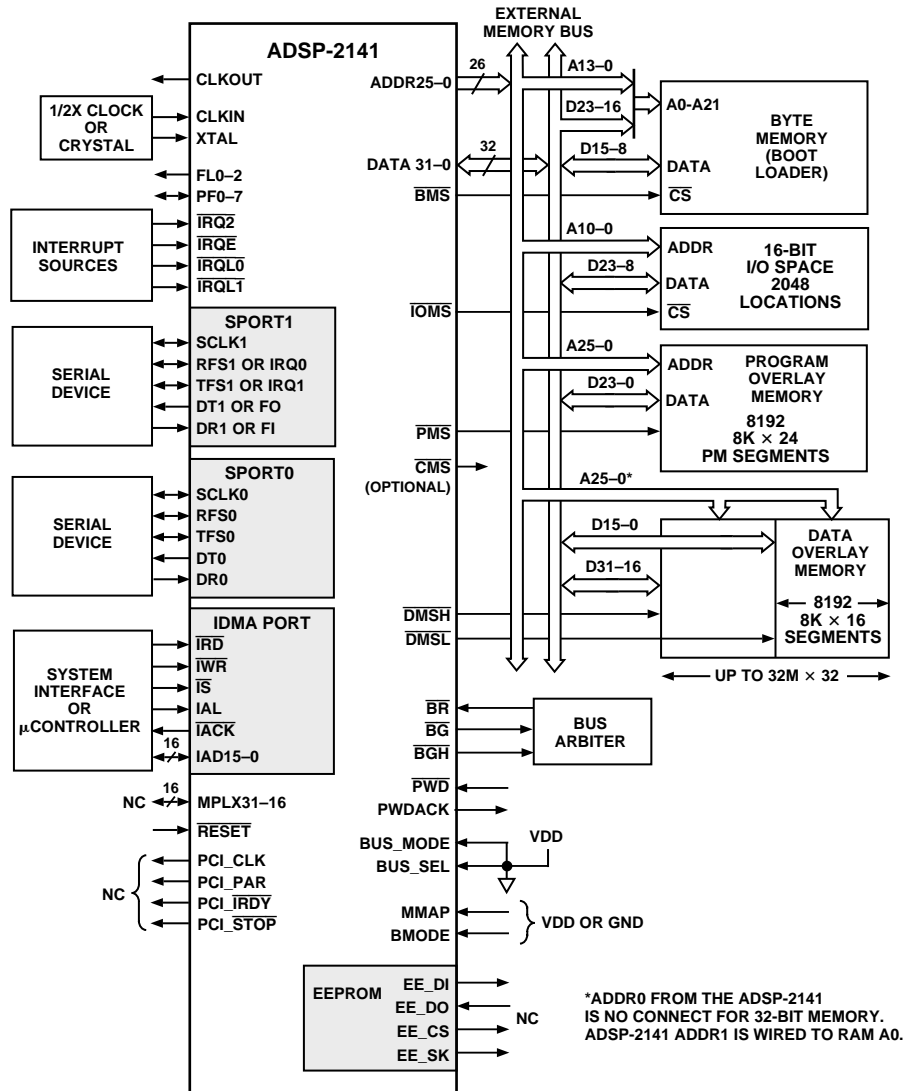

Figure 6. ADSP-2141L IDMA System Configuration

PCI Bus Mode

Figure 7 illustrates a typical system configuration for the PCI mode.

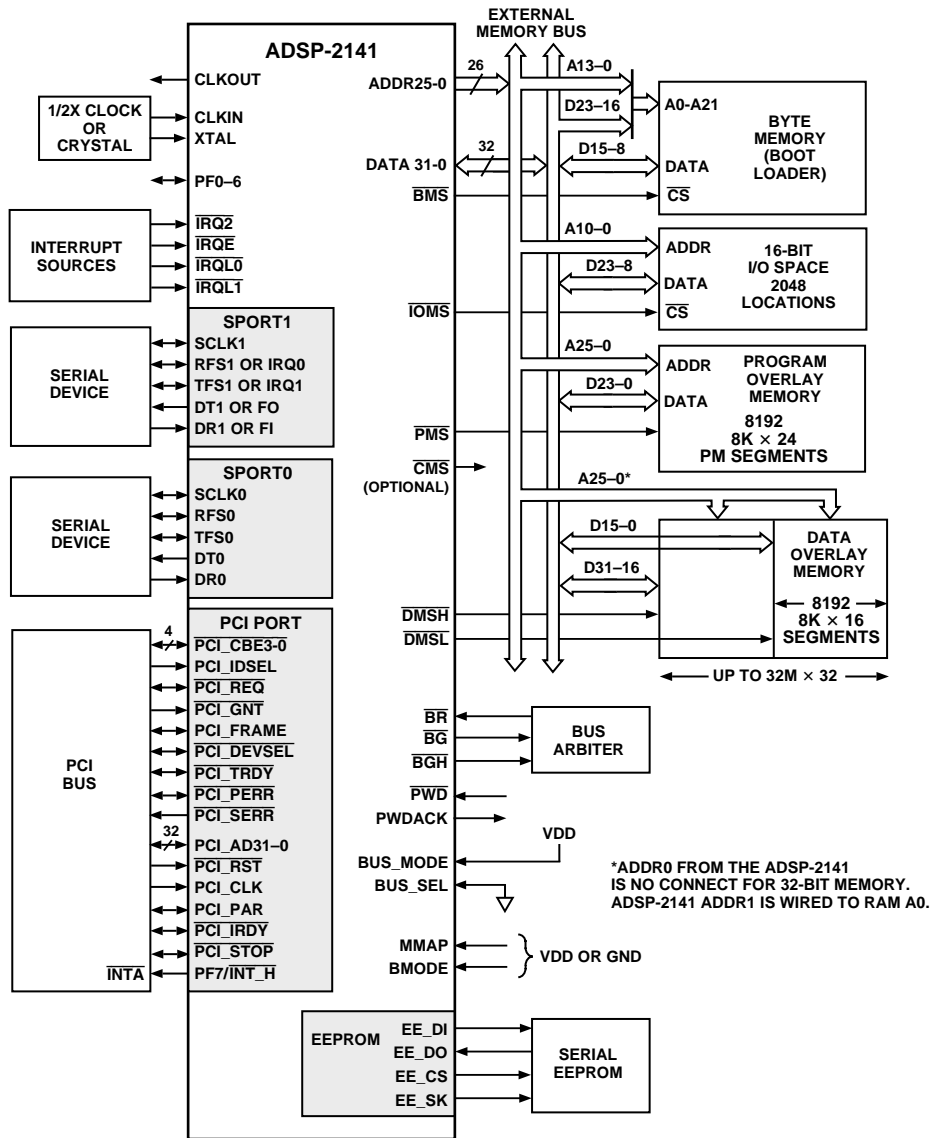

Figure 7. ADSP-2141L PCI System Configuration

ADSP-2141L

DEVICE OPERATION OPERATIONAL MODES

Security Modes

The ADSP-2141L operates in one of two security modes: kernel mode or user mode. The mode switching is performed on the fly as program execution proceeds. Kernel mode is entered via a jump or call to address 0x2000 with PMOVLAY set to 0x000F. Kernel mode will exit on its own once it has completed a requested operation (or terminates due to an error).

Special interrupt handling is performed if the DSP is executing in kernel mode. While executing a CGX command in kernel mode, it is possible to interrupt to a nonprotected vector location and then invoke the kernel again during the interrupt handler. The [IF CONDITION] RTI instruction must be used to return to the kernel from the interrupt handler. The return address and PMOVLAY page must match the interrupted address and PMOVLAY page. If not, the violation reset logic will be triggered. Only one level of kernel mode nesting is permitted. An interrupt to a nonprotected vector location while in nested kernel mode will also trigger the violation reset logic.

While in kernel mode, it is possible to interrupt to a protected vector location. In this case, the processor remains in kernel mode. The [IF CONDITION] RTI instruction must be used to return the processor from the interrupt handler. There is no imposed limit on the number of nested interrupts to a protected vector location.

Bus Modes

The ADSP-2141L Host Bus may be configured for one of two personalities: IDMA Mode or PCI Bus Mode. The selection of mode is made with two hardware control inputs BUS_MODE and BUS_SEL at boot time.

Table II. Bus Mode Selection

Bus Mode Pins	BUS_MODE	BUS_SEL
IDMA Mode	0	0
PCI Bus Mode	1	0

This selection may not be changed after the ADSP-2141L comes out of power-up reset. It is typically expected that the bus mode signals are tied to ground or VDD on the PC Board.

Boot Modes

The ADSP-2141L may be bootstrap-loaded from one of three sources: byte-wide memory, host processor bus, or external program memory. The selection of mode is made with two hardware control inputs BMODE and MMAP. When the host processor boot mode is selected, any one of the two bus modes may be used.

Table III. Boot Mode Selection

Boot Mode Pins	BMODE	MMAP
Byte-Wide (BDMA) Boot Mode	0	0
Host Bus (IDMA) Boot Mode	1	0
External Program Boot Mode	0	1

The hardware pin states are not relevant after the ADSP-2141L comes out of power-up reset. Refer to the *ADSP-2141L User's Manual* (available from IRE) for information on BDMA, IDMA and external program boot modes.

COMMAND INTERFACE

This section provides a general overview of the software command interface to the crypto functions in the ADSP-2141L. Refer to the *ADSP-2141 CGX Interface Programmer's Guide* (available from <http://www.ire-ma.com/proddoc.htm>) for more details.

Overview

The ADSP-2141L provides an embedded crypto library that provides a command interface API (Application Programming Interface) to outside applications. These commands are referred to as CGX (CryptoGraphic eXtensions).

The CGX API simultaneously enforces certain security policies within the ADSP-2141L and insulates applications from the details of many complex cryptographic operations. The security policy built into the ADSP-2141L has some of the following rules:

- Unencrypted (red) keys may never be retrieved from the ADSP-2141L.
- Keys within the ADSP-2141L are marked with an attributes field that specifies key type and trust level.
- A key's type field must match the use in a requested operation (i.e., cannot use a KEK to encrypt traffic).
- Keys generated internal to the ADSP-2141L (i.e., from RNG) are marked as trusted.
- Keys that are negotiated or imported from outside systems are marked untrusted (although they may still be quite secure).
- Separate trusted and untrusted key hierarchies may be maintained and customer applications may choose which trust level is required for a given command.

For most key management operations, the CGX interface must be used. However, for certain high performance encryption/ hashing applications, the CGX interface may be bypassed and either the DSP or a host processor may exercise direct control over the hash/encrypt block.

COMMAND SUMMARY

Approximately 40 CGX Commands are supported in the API to the ADSP-2141L.

General Utilities

INIT	Initializes Secure Kernel and Allow Reconfiguration of the ADSP-2141L
DEFAULT	Restores Factory Default Settings
RANDOM	Generates Random Numbers (between 1K and 64K bytes)
GET CHIPINFO	Returns ADSP-2141L System Information
SELF TEST	Runs a suite of self-tests on the hardware and CGX

Symmetrical Key Management

UNCOVER KEY	Loads and Decrypts a Secret Key
GEN KEY	Generates a Secret Key
GEN KEK	Generates an Internal Key Encryption Key
GEN RKEK	Generates a Key Recovery Key Encryption Key
SAVE KEY	Saves a key protected by the Recovery Key (RKEK)
LOAD KEY	Imports a Red (plaintext) User Secret Key
DERIVE KEY	Derives a Secret Key from a Pass Phrase
TRANSFORM KEY	Transforms a Secret Key using IPsec
DESTROY KEY	Removes Secret Key from the KCR
EXPORT KEY	Exports an IRE-format Secret Key
IMPORT KEY	Imports an IRE-format Secret Key

Symmetrical Encryption

ENCRYPT	Encrypts Data
DECRYPT	Decrypts Data
LOAD KG	Loads Secret Key into HW/SW Key Generator

Hash

HASH INIT	Initializes the Hash Operator
HASH DATA	Hash Customer Data
HASH ENCRYPT	Hash and Encrypt Customer Data
HASH DECRYPT	Hash and Decrypt Customer Data

PRF Functions

MERGE KEY	Combines two secret keys into one key
MERGE LONG KEY	Combines two secret keys into a data string (long key)
EXTRACT LONG KEY	Creates a secret key from a data string (long key)
PRF DATA	Hash multiple data items using HMAC
PRF KEY	Completes the above HMAC and create secret key

Asymmetrical Key Management

GEN PUBKEY	Generates a Public Keyset (Public and Private Parts)
GEN NEWPUBKEY	Generates a part of a Public Keyset
GEN NEGKEY	Generates a Diffie-Hellman Derived Secret Key
EXPORT PUBKEY	Exports an IRE-format Public Key
IMPORT PUBKEY	Imports an IRE-format Public Key

Asymmetrical Encryption

PUBKEY ENCRYPT	Encrypts Data using RSA Public Key
PUBKEY DECRYPT	Decrypts Data using RSA Public Key

Digital Signatures

SIGN	Digitally Signs a Message
VERIFY	Verifies a Digital Signature

Math Utilities

ADD VECTOR	Performs a Vector Add Operation
SUB VECTOR	Performs a Vector Subtract Operation
MULT VECTOR	Performs a Vector Multiply Operation
EXP VECTOR	Performs a Vector Exponentiate Operation
SHIFT VECTOR	Performs a Vector Right or Left Shift Operation

Extended Mode

LOAD EXTENDED	Loads/Enables Extended (Downloaded) Algorithm Block
EXECUTE EXTENDED	Executes Extended (Downloaded) Algorithm Block

ADSP-2141L

ABSOLUTE MAXIMUM RATINGS

Supply Voltage	-0.3 V to +4.6 V
Input Voltage	-0.5 V to $V_{DD} + 0.5$ V
Output Voltage Swing	-0.5 V to $V_{DD} + 0.5$ V
Operating Temperature Range (Ambient)	0°C to 70°C
Storage Temperature Range	-65°C to +150°C
Lead Temperature (5 sec) MQFP	280°C

Frequency Dependency For Timing Specifications

t_{CK} is defined as $0.5t_{CKI}$. The ADSP-2141L uses an input clock with a frequency equal to half the instruction rate: a 20.0 MHz input clock (which is equivalent to 50 ns) yields a 25 ns processor cycle (equivalent to 40 MHz). t_{CK} values within the range of $0.5t_{CKI}$ period should be substituted for all relevant timing parameters to obtain the specification value.

Example: $t_{CKH} = 0.5t_{CK} - 7 \text{ ns} = 0.5 (25 \text{ ns}) - 7 \text{ ns} = 8 \text{ ns}$

CAUTION

ESD (electrostatic discharge) sensitive device. Electrostatic charges as high as 4000 V readily accumulate on the human body and test equipment and can discharge without detection. Although the ADSP-2141L features proprietary ESD protection circuitry, permanent damage may occur on devices subjected to high energy electrostatic discharges. Therefore, proper ESD precautions are recommended to avoid performance degradation or loss of functionality.



SPECIFICATIONS

ADSP-2141L

RECOMMENDED OPERATING CONDITIONS

Parameter		K Grade		Unit
		Min	Max	
V _{DD}	Supply Voltage	3.0	3.6	V
T _{AMB}	Ambient Operating Temperature	0	70	°C

ELECTRICAL CHARACTERISTICS

DC SPECIFICATIONS

Parameter		Test Conditions	K Grade			Unit
			Min	Typ	Max	
V _{IH}	Hi-Level Input Voltage ^{1, 2}	@ V _{DD} = max	2.0			V
V _{IH}	Hi-Level CLKIN/Reset Voltage	@ V _{DD} = max	2.4			V
V _{IL}	Lo-Level Input Voltage ^{1, 3}	@ V _{DD} = min			0.4	V
V _{OH}	Hi-Level Output Voltage ^{1, 4, 5}	@ V _{DD} = min I _{OH} = -0.5 mA	2.4			V
		@ V _{DD} = min I _{OH} = -100 μA ⁶	V _{DD} - 0.3			V
V _{OL}	Lo-Level Output Voltage ^{1, 4, 5}	@ V _{DD} = min I _{OL} = 2 mA			0.4	V
I _{IH}	Hi-Level Input Current ³	@ V _{DD} = max V _{IN} = V _{DD} max			10	μA
I _{IL}	Lo-Level Input Current ³	3 @ V _{DD} = max V _{IN} = 0 V			10	μA
I _{OZH}	Three-State Leakage Current ⁷	@ V _{DD} = max V _{IN} = V _{DD} max ⁸			10	μA
I _{OZL}	Three-State Leakage Current ⁹	@ V _{DD} = max V _{IN} = 0 V ⁹			8	μA
I _{DD}	Supply Current (Idle) ^{10, 11}	@ V _{DD} = 3.3 T _{AMB} = 25°C t _{CK} = 25 ns ¹² t _{CK} = 30 ns ¹²		16 15		mA mA
I _{DD}	Supply Current (Dynamic) ^{11, 13}	@ V _{DD} = 3.3 T _{AMB} = 25°C t _{CK} = 25 ns ¹² t _{CK} = 30 ns ¹²		195 165		mA mA
C _I	Input Pin Capacitance ^{3, 6, 14}	@ V _{IN} = 2.5 V f _{IN} = 1.0 MHz T _{AMB} = 25°C			8	pF
C _O	Output Pin Capacitance ^{6, 7, 14, 15}	@ V _{IN} = 2.5 V f _{IN} = 1.0 MHz T _{AMB} = 25°C			8	pF

NOTES

- ¹ Bidirectional pins: D0–D31, RFS0, RFS1, SCLK0, SCLK1, TFS0, TFS1, IAD0–15, PF0–PF7.
- ² Input only pins: IRQ2, BR, MMAP, BMODE, BUS MODE, BUS SEL, DR0, DR1, PWD, IRQL0, IRQL1, IRQE, IS, IRD, IWR, IAL.
- ³ Input only pins: CLKIN, RESET, IRQ2, BR, MMAP, BMODE, BUS MODE, BUS SEL, DR0, DR1, PWD, IRQL0, IRQL1, IRQE, IS, IRD, IWR, IAL.
- ⁴ Output pins: BG, BGH, PMS, DMSL, DMSH, BMS, IOMS, CMS, RD, WR, IACK, PWDACK, A0–A25, DT0, DT1, CLKOUT, FL2–0.
- ⁵ Although specified for TTL outputs, all ADSP-2141L outputs are CMOS-compatible and will drive to V_{DD} and GND, assuming no dc loads.
- ⁶ Guaranteed but not tested.
- ⁷ Output pins: BG, BGH, PMS, DMSL, DMSH, BMS, IOMS, CMS, RD, WR, IACK, PWDACK, A0–A25, DT0, DT1, CLKOUT, FL2–0, EE_DI, EE_CS, EE_SK.
- ⁸ 0 V on BR. CLKIN active (to force three-state condition).
- ⁹ Three-statable pins: A0–A25, D0–D31, PMS, DMSL, DMSH, BMS, IOMS, CMS, RD, WR, DT0, DT1, SCKL0, SCLK1, TFS0, TFS1, RFS0, RFS1, IAD0–IAD15, PF0–PF7.
- ¹⁰ Idle refers to ADSP-2141L state of operation during execution of IDLE instruction. Deasserted pins are driven to either V_{DD} or GND.
- ¹¹ Current reflects device operating with no output loads.
- ¹² V_{IN} = 0.4 V and 2.4 V. For typical supply currents, refer to Power Dissipation section.
- ¹³ I_{DD} measurement taken with 93% of instructions executing from internal memory and 7% from external memory. H/E operations are executing from internal memory concurrently with PCI transactions. Initialization operations are executed from external memory.
- ¹⁴ Applies to MQFP package type.
- ¹⁵ Output pin capacitance is the capacitive load for any three-stated output pin.

Specifications subject to change without notice.

ADSP-2141L

DC SPECIFICATIONS— PCI Bus Pins

Parameter	Test Conditions	K Grade		Unit
		Min	Max	
V_{IH}	Hi-Level Input Voltage ^{1, 2}	$0.5 V_{DD}$	$V_{DD} + 0.5$	V
V_{IL}	Lo-Level Input Voltage ^{1, 2}	-0.5	$0.3 V_{DD}$	V
V_{OH}	Hi-Level Output Voltage ^{1, 3}	$0.9 V_{DD}$		V
V_{OL}	Lo-Level Output Voltage ^{1, 3}		$0.1 V_{DD}$	V
I_{IH}	Hi-Level Input Current ²	$I_{OUT} = -500 \mu A$	10	μA
I_{IL}	Lo-Level Input Current ²	$I_{OUT} = 1500 \mu A$	10	μA
I_{OZH}	Three-State Leakage Current ⁴	$0 < V_{IN} < V_{DD}$	10	μA
I_{OZL}	Three-State Leakage Current ¹	$0 < V_{IN} < V_{DD}$	10	μA
C_I	Input Pin Capacitance	$T_{AMB} = 25^\circ C$	10	pF
C_{CLK}	PCI CLK Pin Capacitance	$T_{AMB} = 25^\circ C$	12	pF
C_{IDSEL}	PCI IDSEL Pin Capacitance ⁵	$T_{AMB} = 25^\circ C$	8	pF
L_{PIN}	Pin Inductance		20	nH

NOTES

¹Bidirectional pins: MPLX_BUS [31:0], MPLX1-4, MPLX7-10, MPLX12

²Input only pins: MPLX_RESET, MPLX5, MPLX6, PCI_CLK, PCI_PAR, PCI_IRDY, PCI_STOP

³Output only pins: MPLX11

⁴Leakage currents include High-Z output leakage for bidirectional buffers with three-state outputs.

⁵Lower capacitance of IDSEL (MPLX_5) input-only pin allows for nonresistive connection to Address/Data bus.

TIMING PARAMETERS

PCI Clock (Guaranteed Over Operating Temperature and Digital Supply Range)

The ADSP-2141L is targeted for use in PCI add-on I/O slave card designs. It provides a glueless interface to the PCI bus. All bus drivers are compliant with PCI interface electrical switching and drive capability specifications.

The ADSP-2141L does not implement the following signals: \overline{LOCK} , \overline{INTB} , \overline{INTC} , \overline{INTD} , \overline{SBO} , \overline{SDONE} , \overline{CLKRUN} , AD[64:32], C/BE[7:4], REQ64, ACK64, PAR64.

Parameter		Min	Max	Unit
<i>Timing Requirements:</i>				
t_{CYC}	CLK Cycle Time	25	100	ns
t_{HIGH}	CLK High Time	11		ns
t_{LOW}	CLK Low Time	11		ns
	CLK Slew Rate ¹	1	4	V/ns
	\overline{RST} Slew Rate ²	50		mV/ns

NOTES

¹Rise and fall times are specified in terms of the edge rate measured in V/ns. This slew rate must be met across the minimum peak-to-peak portion of the waveform as shown in Figure 8.

²The minimum \overline{RST} slew rate applies only to the rising (deassertion) edge of the reset signal, and ensures that system noise cannot render an otherwise monotonic signal to appear to bounce in the switching range.

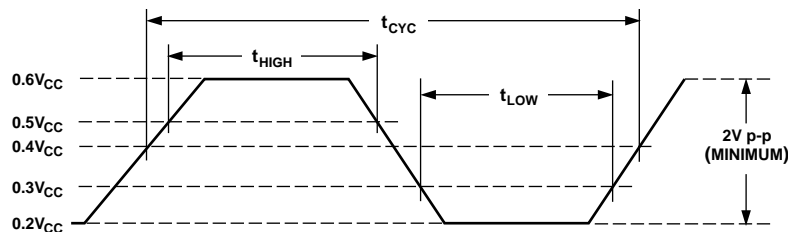

Figure 8. Clock Waveform

Parameter	Min	Max	Unit
PCI Bus Interface			
<i>Timing Requirements:</i>			
t_{VAL} CLK to Signal Valid	2	11	ns
t_{ON} CLK to Low-Z Delay	2		ns
t_{OFF} CLK to High-Z Delay		28	ns
t_{SU} Input Setup to CLK	7		ns
t_H Input Hold After CLK	1		ns
$t_{RST-OFF}$ \overline{RST} Active to Outputs High-Z		40	ns

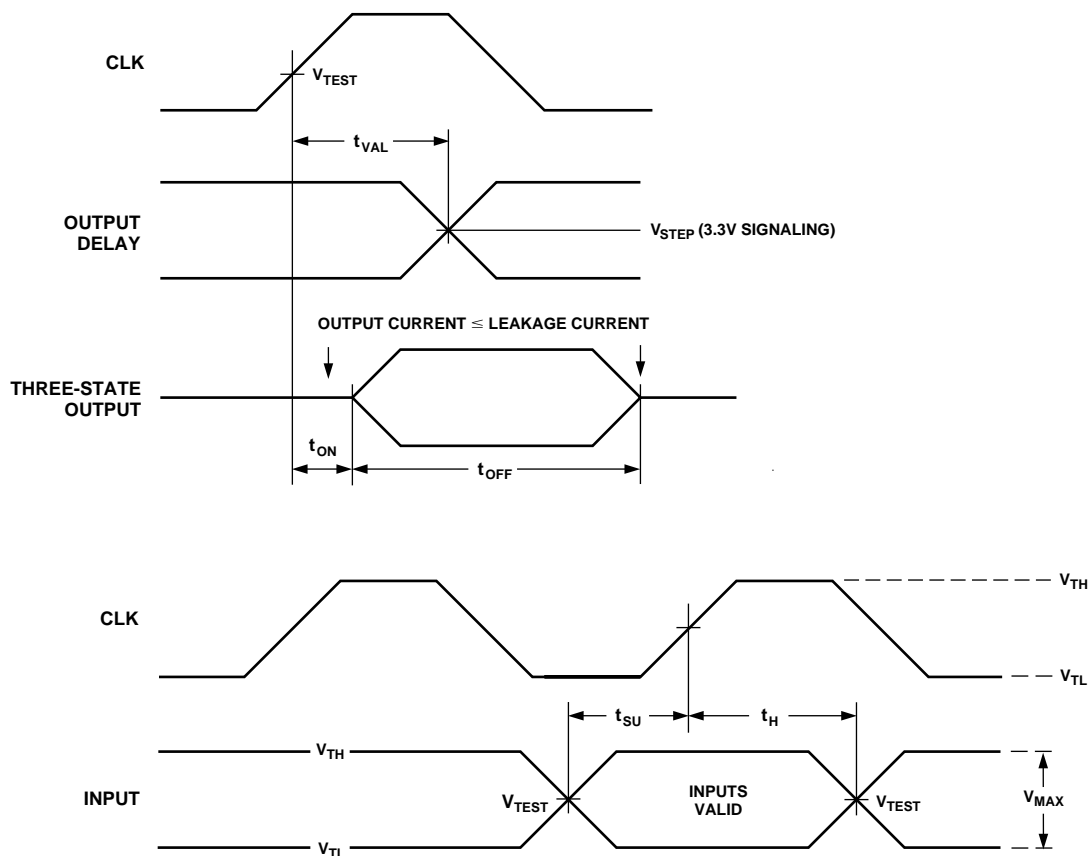

Figure 9. Output (Top) and Input Timing Measurement Conditions

ADSP-2141L

Parameter	Min	Max	Unit
Clock Signals and Reset			
<i>Timing Requirements:</i>			
t_{CKI} CLKIN Period	50	100	ns
t_{CKIL} CLKIN Width Low	15		ns
t_{CKIH} CLKIN Width High	15		ns
<i>Switching Characteristics:</i>			
t_{CKL} CLKOUT Width Low	$0.5t_{CK} - 7$		ns
t_{CKH} CLKOUT Width High	$0.5t_{CK} - 7$		ns
t_{CKOH} CLKIN High to CLKOUT High	0	20	ns
Control Signals			
<i>Timing Requirement:</i>			
t_{RSP} RESET Width Low ¹	$5t_{CK}$		ns

NOTE

¹Applies after power-up sequence is complete. Internal phase lock loop requires no more than 2000 CLKIN cycles assuming stable CLKIN (not including crystal oscillator start-up time).

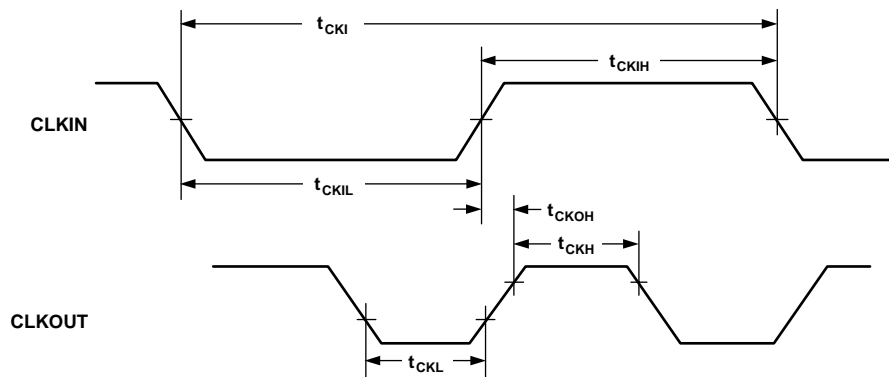

Figure 10. Clock Signals and Reset

Parameter	Min	Max	Unit
Interrupts and Flags			
<i>Timing Requirements:</i>			
t_{IFS}	\overline{IRQx} , FI, or PFx Setup Before CLKOUT Low ^{1, 2, 3, 4}		ns
t_{IFH}	\overline{IRQx} , FI, or PFx Hold After CLKOUT High ^{1, 2, 3, 4}		ns
<i>Switching Characteristics:</i>			
t_{FOH}	Flag Output Hold After CLKOUT Low ⁵		ns
t_{FOD}	Flag Output Delay from CLKOUT Low ⁵		ns

NOTES

¹If \overline{IRQx} and FI inputs meet t_{IFS} and t_{IFH} setup/hold requirements, they will be recognized during the current clock cycle; otherwise the signals will be recognized on the following cycle. (Refer to the Interrupt Controller Operation section in the Program Control chapter of the *ADSP-2100 Family User's Manual* for further information on interrupt servicing.)

²Edge-sensitive interrupts require pulsewidths greater than 10 ns; level-sensitive interrupts must be held low until serviced.

³ \overline{IRQx} = $\overline{IRQ0}$, $\overline{IRQ1}$, $\overline{IRQ2}$, $\overline{IRQL0}$, $\overline{IRQL1}$, \overline{IRQE} .

⁴PFx = PF0, PF1, PF2, PF3, PF4, PF5, PF6, PF7.

⁵Flag Outputs = PFx, FL0, FL1, FL2, Flag_out.

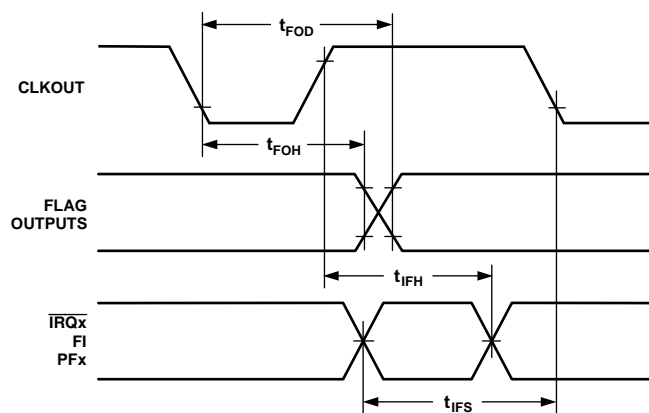

Figure 11. Interrupts and Flags

ADSP-2141L

Parameter	Min	Max	Unit
Bus Request/Bus Grant			
<i>Timing Requirements:</i>			
t_{BH}	$0.25t_{CK} + 2$		ns
t_{BS}	$0.25t_{CK} + 17$		ns
<i>Switching Characteristics:</i>			
t_{SD}		$0.25t_{CK} + 10$	ns
t_{SDB}	0		ns
t_{SE}	0		ns
t_{SEC}	$0.25t_{CK} - 6$		ns
t_{SDBH}	0		ns
t_{SEH}	0		ns

NOTES

$\overline{xMS} = \overline{PMS}, \overline{DMSL}, \overline{DMSH}, \overline{CMS}, \overline{IOMS}, \overline{BMS}$.

¹ \overline{BR} is an asynchronous signal. If \overline{BR} meets the setup/hold requirements, it will be recognized during the current clock cycle; otherwise, the signal will be recognized on the following cycle. Refer to the *ADSP-2100 Family User's Manual* for $\overline{BR}/\overline{BG}$ cycle relationships.

² \overline{BGH} is asserted when the bus is granted and the processor requires control of the bus to continue.

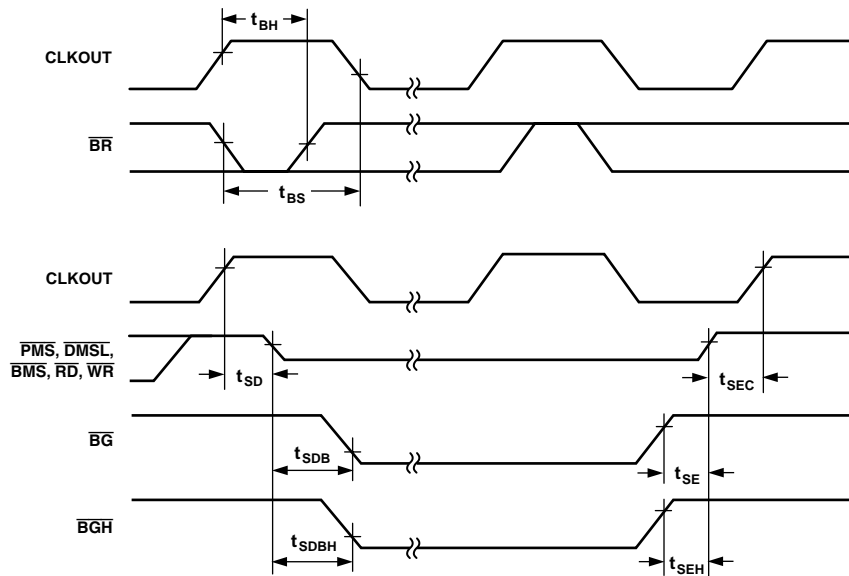

Figure 12. Bus Request/Bus Grant

Parameter	Min	Max	Unit
External Memory Write: ADSP-2141L DMA Initiated			
<i>Switching Characteristics:</i>			
t_A Clock to Address and \overline{DMSx}	5	9	ns
t_{DW} Data Setup Before Write Deasserted	$0.5t_{CK} - 2 + w$		ns
t_{DH} Data Hold After Write Deasserted	$0.5t_{CK} - 8$		ns
t_{WP} Write Pulsewidth	$0.5t_{CK} - 5 + w$		ns
t_{WDE} Write Low to Data Enabled	-5		ns
t_{ASW} Address, \overline{DMSx} Setup Before Write Low	1		ns
t_{DDR} Data Disable Before Write/Read Low	0		ns
t_{CWR} Clock High to Write Low	6	12	ns
t_{AW} Address, \overline{DMSx} Setup Before Write High	$0.5t_{CK} - 2 + w$		ns
t_{AH} Address and \overline{DMSx} Hold After Clock	2		ns
t_{WRA} Address, \overline{DMSx} Hold After Write High	$0.5t_{CK} - 7$		ns
t_{WWR} Write High to Read/Write Low	$0.5t_{CK} - 3$		ns

1. If wait-state(s) added, then referenced to last wait-state clock interval.
2. $w = \text{DMA wait states} \times t_{CK}$.

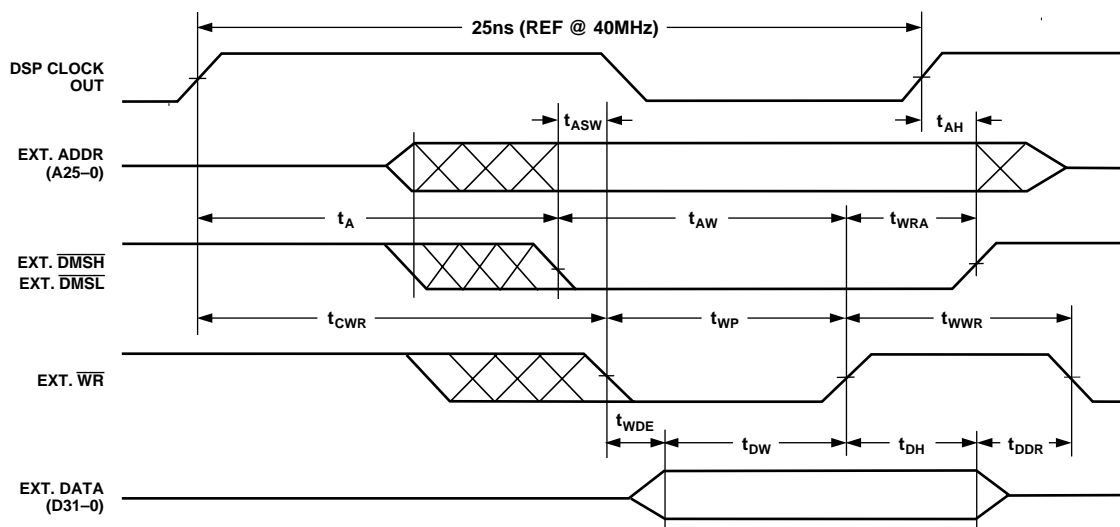

Figure 13. External Memory Write: ADSP-2141L DMA Initiated

ADSP-2141L

Parameter		Min	Max	Unit
External Memory Read—ADSP-2141L DMA Initiated				
<i>Timing Requirements:</i>				
t_{RDD}	Read Low to Data Valid		$0.5t_{CK} - 8 + w$	ns
t_{AA}	Address, \overline{DMSx} Valid to Data Valid		$0.5t_{CK} - 3 + w$	ns
t_{SUR}	Data Valid Before Read Deasserted	4		ns
t_{RDH}	Data Hold After Read Deasserted	1		ns
<i>Switching Characteristics:</i>				
t_A	Clock to Address and \overline{DMSx} Active	5	9	ns
t_{ASR}	Address, \overline{DMSx} Setup Before Read Low	2		ns
t_{AH}	Address and \overline{DMSx} Hold After Clock	2		ns
t_{RDA}	Address, \overline{DMSx} Hold After Read High	$0.5t_{CK} - 7$		ns
t_{CRD}	Clock High to \overline{RD} Low	8	12	ns
t_{RP}	Read Pulsewidth	$0.5t_{CK} - 5 + w$		ns
t_{RWR}	\overline{RD} High to Read or Write Low	$0.5t_{CK} - 3$		ns

1. If wait-state(s) added, then referenced to last wait-state clock interval.
2. $w = \text{DMA wait states} \times t_{CK}$.

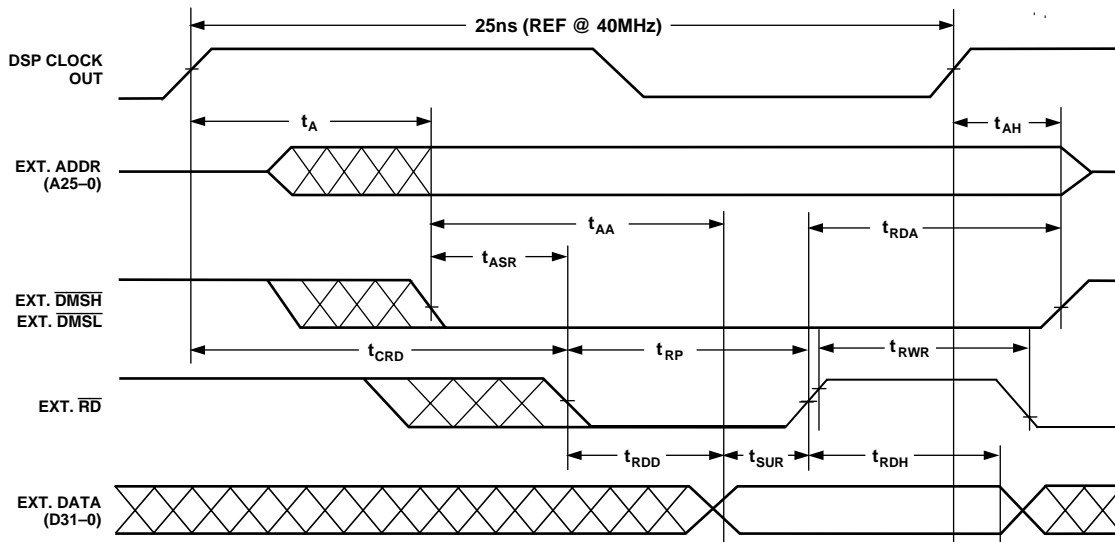

Figure 14. External Memory Read – ADSP-2141L DMA Initiated

Parameter	Min	Max	Unit
External Memory Write: ADSP-2141L DSP Initiated			
<i>Switching Characteristics:</i>			
t_A		6	ns
t_{DW}	$0.5t_{CK} - 7 + w$		ns
t_{DH}	$0.25t_{CK} - 3.5$		ns
t_{WP}	$0.5t_{CK} - 5 + w$		ns
t_{WDE}	0		ns
t_{ASW}	$0.25t_{CK} - 4$		ns
t_{DDR}	$0.25t_{CK} - 4$		ns
t_{CWR}	$0.25t_{CK}$	$0.5t_{CK} + 9$	ns
t_{AW}	$0.75t_{CK} - 6 + w$		ns
t_{AH}	1		ns
t_{WRA}	$0.25t_{CK} - 4$		ns
t_{WWR}	$0.5t_{CK} - 5$		ns

1. If wait-state(s) added, then referenced to last wait-state clock interval.
2. $w = \text{DSP wait states} \times t_{CK}$.

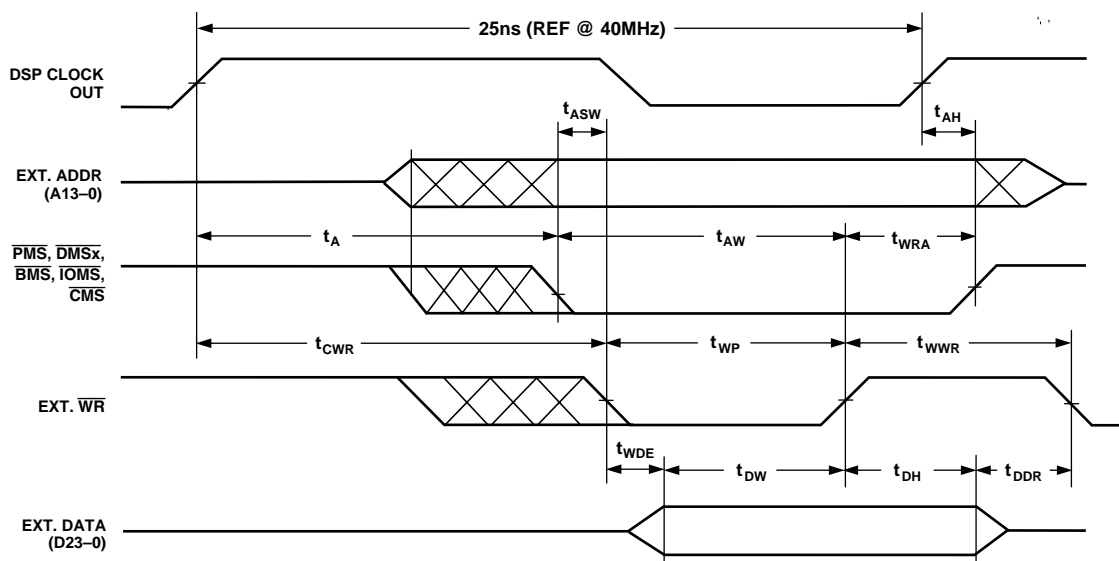

Figure 15. External Memory Write: ADSP-2141L DSP Initiated

ADSP-2141L

Parameter		Min	Max	Unit
External Memory Read—ADSP-2141L DSP Initiated				
<i>Timing Requirements:</i>				
t_{RDD}	Read Low to Data Valid		$0.5t_{CK} - 10 + w$	ns
t_{AA}	Address, \overline{xMS} Valid to Data Valid		$0.75t_{CK} - 11.5 + w$	ns
t_{SUR}	Data Valid Before Read Deasserted	9		ns
t_{RDH}	Data Hold After Read Deasserted	0		ns
<i>Switching Characteristics:</i>				
t_A	Clock to Address, \overline{xMS} Active	1	6	ns
t_{ASR}	Address, \overline{xMS} Setup Before Read Low	$0.25t_{CK} - 4$		ns
t_{AH}	Address, \overline{xMS} Hold After Clock	1		ns
t_{RDA}	Address, \overline{xMS} Hold After Read High	$0.25t_{CK} - 3$		ns
t_{CRD}	Clock High to \overline{RD} Low	$0.25t_{CK} - 2$	$0.25t_{CK} + 7$	ns
t_{RP}	Read Pulsewidth	$0.5t_{CK} - 5 + w$		ns
t_{RWR}	\overline{RD} High to \overline{RD} or \overline{WR} Low	$0.5t_{CK} - 5$		ns

1. If wait-state(s) added, then referenced to last wait-state clock interval.
2. $w = \text{DSP wait state} \times t_{CK}$.

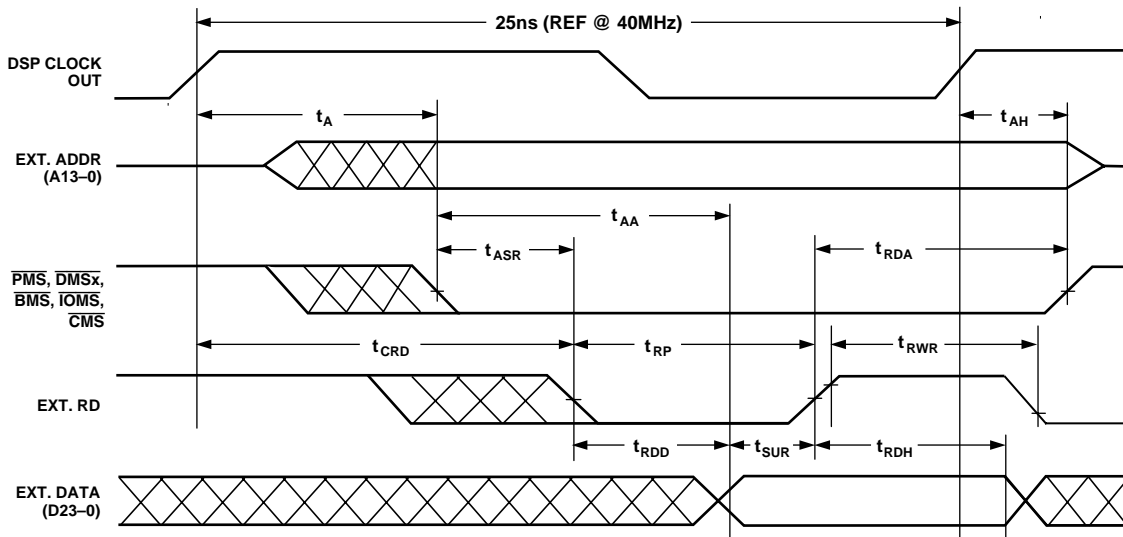

Figure 16. External Memory Read – ADSP-2141L DSP Initiated

Parameter	Min	Max	Unit
Serial Ports			
<i>Timing Requirements:</i>			
t_{SCK} SCLK Period	50		ns
t_{SCS} DR/TFS/RFS Setup Before SCLK Low	4		ns
t_{SCH} DR/TFS/RFS Hold After SCLK Low	7		ns
t_{SCP} SCLK _{IN} Width	15		ns
<i>Switching Characteristics:</i>			
t_{CC} CLKOUT High to SCLKOUT	$0.25t_{CK}$	$0.25t_{CK} + 10$	ns
t_{SCDE} SCLK High to DT Enable	0		ns
t_{SCDV} SCLK High to DT Valid		15	ns
t_{RH} TFS/RFS _{OUT} Hold After SCLK High	0		ns
t_{RD} TFS/RFS _{OUT} Delay from SCLK High		15	ns
t_{SCDH} DT Hold After SCLK High	0		ns
t_{TDE} TFS (Alt) to DT Enable	0		ns
t_{TDV} TFS (Alt) to DT Valid		14	ns
t_{SCDD} SCLK High to DT Disable		15	ns
t_{RDV} RFS (Multichannel, Frame Delay Zero) to DT Valid		15	ns

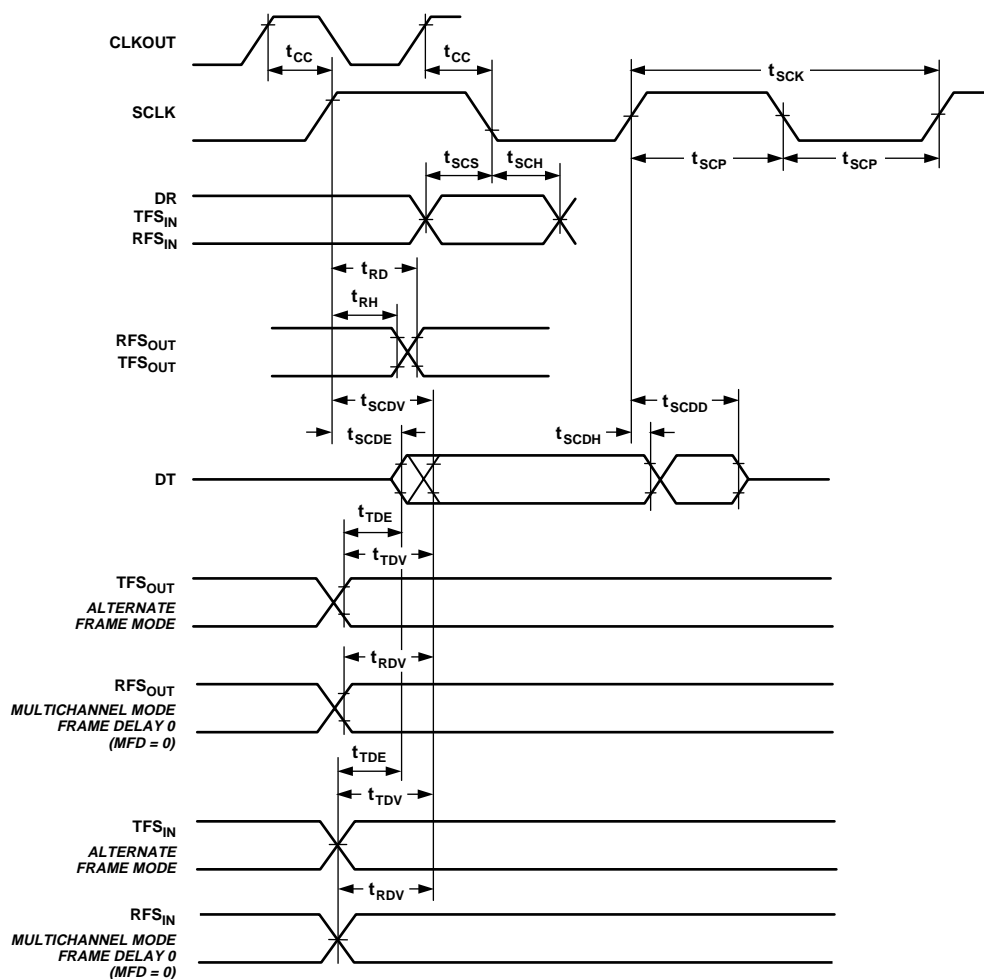

Figure 17. Serial Ports

ADSP-2141L

Parameter	Min	Max	Unit
IDMA Address Latch (IDMA Mode Multiplex Bus)			
<i>Timing Requirements:</i>			
t_{IALP}			ns
Duration of Address Latch ^{1, 2}	10		ns
t_{IASU}	5		ns
MPLX_BUS Address Setup Before Address Latch End ²	3		ns
t_{IAH}	3		ns
MPLX_BUS Address Hold After Address Latch End ²	0		ns
t_{IKA}	0		ns
MPLX9 Low Before Start of Address Latch ^{2, 3}	4		ns
t_{IALS}	4		ns
Start of Write or Read After Address Latch End ^{2, 3}			ns

NOTES

¹Start of Address Latch = MPLX7 Low and MPLX8 High.

²Start of Write or Read = MPLX7 Low and MPLX6 Low or MPLX5 Low.

³End of Address Latch = MPLX7 High or MPLX8 Low.

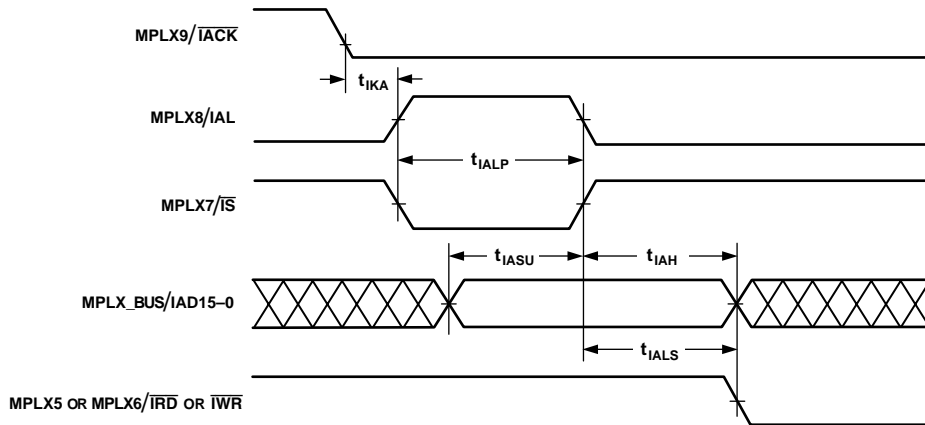

Figure 18. IDMA Address Latch (IDMA Mode Multiplex Bus)

Parameter	Min	Max	Unit
IDMA Write, Short Write Cycle (IDMA Mode, Multiplex Bus)			
<i>Timing Requirements:</i>			
t_{IKW}		0	ns
t_{IWP}		15	ns
t_{IDSU}		5	ns
t_{IDH}		3	ns
<i>Switching Characteristic:</i>			
t_{IKHW}		15	ns

NOTES

¹Start of Write = MPLX7 Low and MPLX6 Low.

²End of Write = MPLX7 High or MPLX6 High.

³If Write Pulse ends before MPLX9 Low, use specifications t_{IDSU} , t_{IDH} .

⁴If Write Pulse ends after MPLX9 Low, use specifications t_{IKSU} , t_{IKH} .

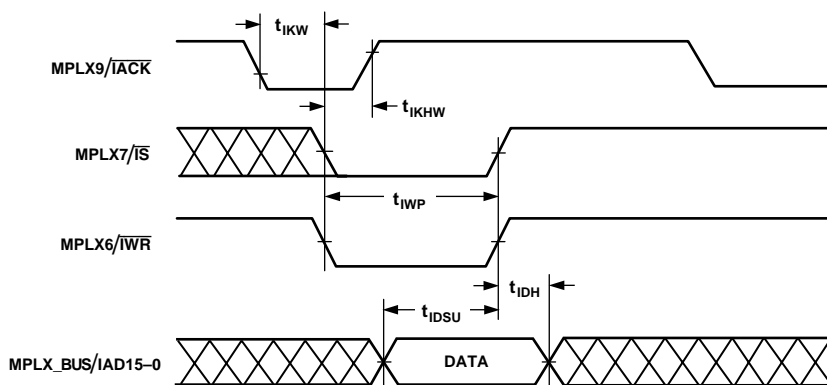

Figure 19. IDMA Write, Short Write Cycle (IDMA Mode, Multiplex Bus)

ADSP-2141L

Parameter	Min	Max	Unit
IDMA Write, Long Write Cycle (IDMA Mode, Multiplex Bus)			
<i>Timing Requirements:</i>			
t_{IKW}	MPLX9 Low Before Start of Write ¹	0	ns
t_{IKSU}	MPLX_BUS Data Setup Before MPLX9 Low ^{2, 3, 4}	$0.5t_{CK} + 10$	ns
t_{IKH}	MPLX_BUS Data Hold After MPLX9 Low ^{2, 3, 4}	2	ns
<i>Switching Characteristics:</i>			
t_{IKLW}	Start of Write to MPLX9 Low ⁴	$1.5t_{CK}$	ns
t_{IKHW}	Start of Write to MPLX9 High	15	ns

NOTES

¹Start of Write = MPLX7 Low and MPLX6 Low.

²If Write Pulse ends before MPLX9 Low, use specifications t_{IDSU} , t_{IDH} .

³If Write Pulse ends after MPLX9 Low, use specifications t_{IKSU} , t_{IKH} .

⁴This is the earliest time for MPLX9 Low from Start of Write. For IDMA Write cycle relationships, please refer to the *ADSP-2100 Family User's Manual*.

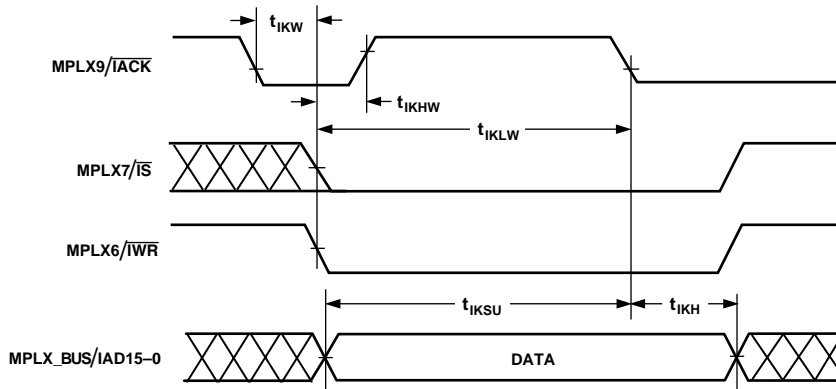

Figure 20. IDMA Write, Long Write Cycle (IDMA Mode, Multiplex Bus)

Parameter	Min	Max	Unit
IDMA Read, Long Read Cycle (IDMA Mode, Multiplex Bus)			
<i>Timing Requirements:</i>			
t_{IKR} MPLX9 Low Before Start of Read ¹	0		ns
t_{IRP} Duration of Read ¹	15		ns
<i>Switching Characteristics:</i>			
t_{IKHR} MPLX9 High After Start of Read ¹		15	ns
t_{IKDS} MPLX_BUS Data Setup Before MPLX9 Low	$0.5t_{CK} - 7$		ns
t_{IKDH} MPLX_BUS Data Hold After End of Read ²	0		ns
t_{IKDD} MPLX_BUS Data Disabled After End of Read ²		14	ns
t_{IRDE} MPLX_BUS Previous Data Enabled After Start of Read	0		ns
t_{IRDV} MPLX_BUS Previous Data Valid After Start of Read		15	ns
t_{IRDH1} MPLX_BUS Previous Data Hold After Start of Read (DM/PM1) ³	$2t_{CK} - 5$		ns
t_{IRDH2} MPLX_BUS Previous Data Hold After Start of Read (PM2) ⁴	$t_{CK} - 5$		ns

NOTES

¹Start of Read = MPLX7 Low and MPLX5 Low.

²End of Read = MPLX7 High or MPLX5 High.

³DM read or first half of PM read.

⁴Second half of PM read.

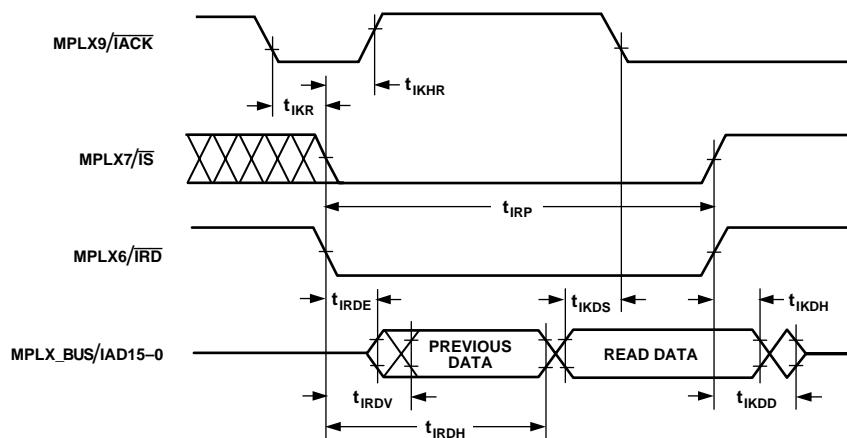

Figure 21. IDMA Read, Long Read Cycle (IDMA Mode, Multiplex Bus)

ADSP-2141L

Parameter	Min	Max	Unit
IDMA Read, Short Read Cycle (IDMA Mode, Multiplex Bus)			
<i>Timing Requirements:</i>			
t_{IKR}	MPLX9 Low Before Start of Read ¹	0	ns
t_{IRP}	Duration of Read	15	ns
<i>Switching Characteristics:</i>			
t_{IKHR}	MPLX9 High After Start of Read ¹	15	ns
t_{IKDH}	MPLX_BUS Data Hold After End of Read ²	0	ns
t_{IKDD}	MPLX_BUS Data Disabled After End of Read ²	14	ns
t_{IRDE}	MPLX_BUS Previous Data Enabled After Start of Read	0	ns
t_{IRDV}	MPLX_BUS Previous Data Valid After Start of Read	15	ns

NOTES

¹Start of Read = MPLX7 Low and MPLX5 Low.

²End of Read = MPLX7 High or MPLX5 High.

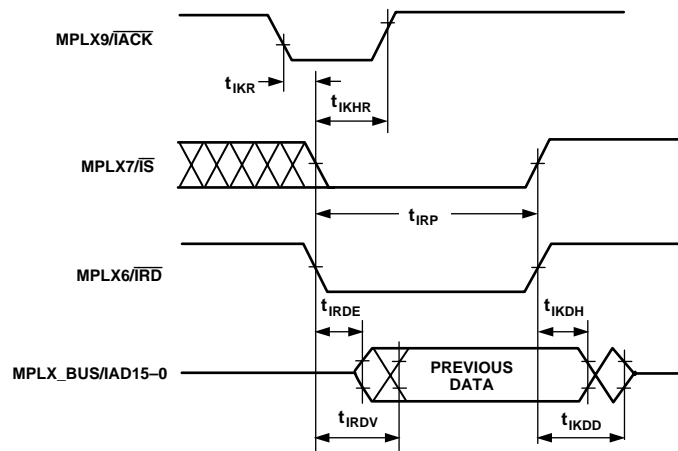

Figure 22. IDMA Read, Short Read Cycle (IDMA Mode, Multiplex Bus)

CAPACITIVE LOADING

Figures 23 and 24 show the capacitive loading characteristics of the ADSP-2141L.

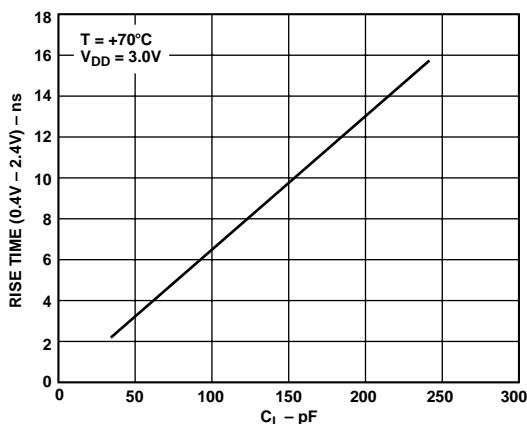

Figure 23. Typical Output Rise Time vs. Load Capacitance, C_L (at Maximum Ambient Operating Temperature)

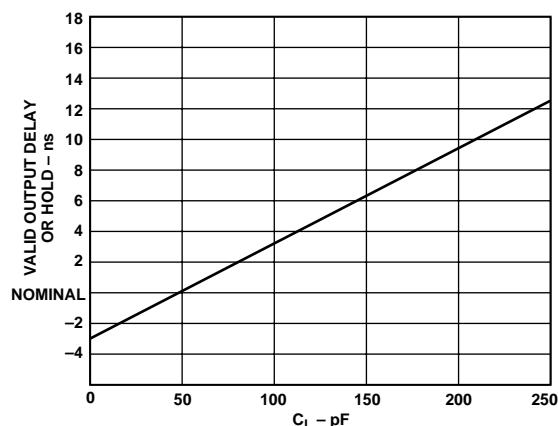

Figure 24. Typical Output Valid Delay or Hold vs. Load Capacitance, C_L (at Maximum Ambient Operating Temperature)

TEST CONDITIONS

Output Disable Time

Output pins are considered to be disabled when they have stopped driving and started a transition from the measured output high or low voltage to a high impedance state. The output disable time (t_{DIS}) is the difference of $t_{MEASURED}$ and t_{DECAY} , as shown in the Output Enable/Disable diagram. The time is the interval from when a reference signal reaches a high or low voltage level to when the output voltages have changed by 0.5 V from the measured output high or low voltage. The decay time, t_{DECAY} , is dependent on the capacitive load, C_L , and the current load, i_L , on the output pin. It can be approximated by the following equation:

$$t_{DECAY} = \frac{C_L \cdot 0.5V}{i_L}$$

from which

$$t_{DIS} = t_{MEASURED} - t_{DECAY}$$

is calculated. If multiple pins (such as the data bus) are disabled, the measurement value is that of the last pin to stop driving.



Figure 25. Voltage Reference Levels for AC Measurements (Except Output Enable/Disable)

Output Enable Time

Output pins are considered to be enabled when they have made a transition from a high-impedance state to when they start driving. The output enable time (t_{ENA}) is the interval from when a reference signal reaches a high or low voltage level to when the output has reached a specified high or low trip point, as shown in the Output Enable/Disable diagram. If multiple pins (such as the data bus) are enabled, the measurement value is that of the first pin to start driving.

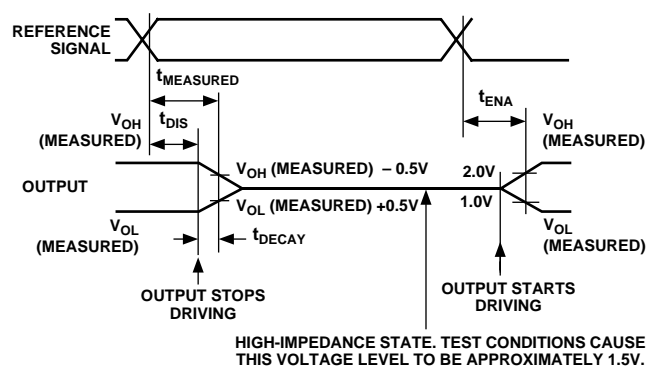

Figure 26. Output Enable/Disable

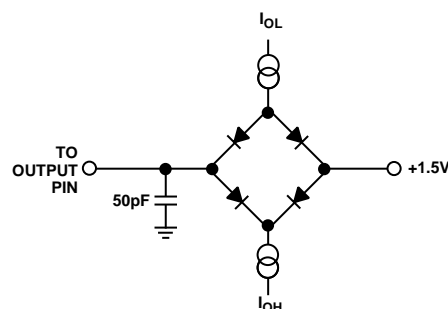

Figure 27. Equivalent Device Loading for AC Measurements (Including All Fixtures)

ADSP-2141L

Table IV. Thermal Ratings: MQFP Package

Rating Description	Symbol	Value (MQFP Still Air)	Value (MQFP 9500 fpm)
Thermal Resistance (Case to Ambient)	θ_{CA}	30.7°C/W	16.7°C/W
Thermal Resistance (Junction to Ambient)	θ_{JA}	35°C/W	21°C/W
Thermal Resistance (Junction to Case)	θ_{JC}	4.3°C/W	4.3°C/W

ENVIRONMENTAL CONDITIONS

The following figures assume a four-layer JEDEC printed circuit board:

$$T_{AMB} = T_{CASE} - (PD \times \theta_{CA})$$

$$T_{CASE} = \text{Case Temperature in } ^\circ\text{C}$$

OUTPUT DRIVE CURRENTS

Figures 28 and 29 show typical I-V characteristics for the output drivers of the ADSP-2141L. The curves represent the current drive capability of the output drivers as a function of output voltage.

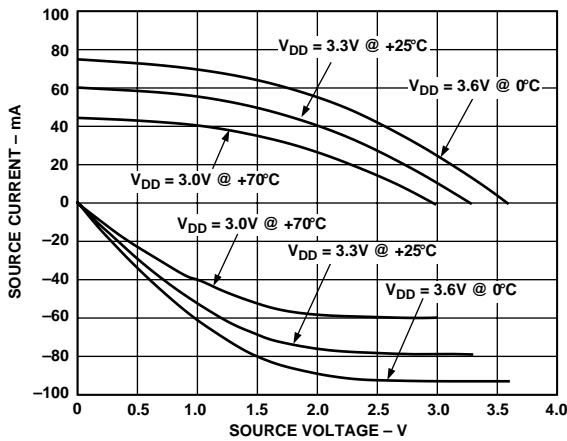

Figure 28. Typical Drive Currents (PCI Pins)

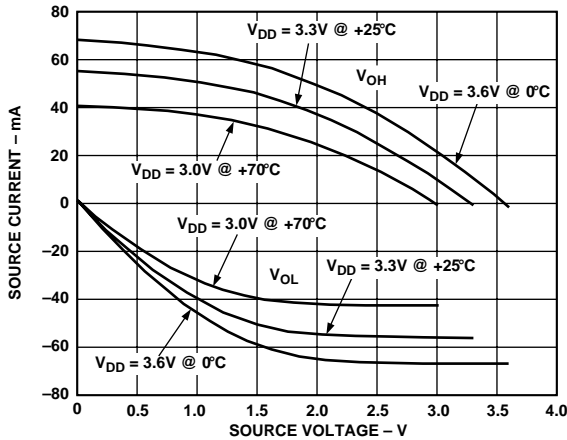

Figure 29. Typical Drive Currents (Addr/Dbus/rd/wr Pins)

POWER DISSIPATION

Total power dissipation has two components: one due to internal circuitry and one due to the switching of external output drivers. Internal power dissipation depends on the sequence in which instructions execute and the data operands involved. See I_{DDIN} calculation in Electrical Characteristics section. Internal power dissipation is calculated this way:

$$P_{INT} = I_{DDIN} \times V_{DD}$$

The external component of total power dissipation is caused by the switching of output pins. Its magnitude depends on:

- the number of output pins that switch during each cycle (O)
- the maximum frequency at which the pins can switch (f)
- the load capacitance of the pins (C)
- the voltage swing of the pins (V_{DD}).

The external component is calculated using:

$$P_{EXT} = O \times C \times V_{DD}^2 \times f$$

The load capacitance should include the processor's package capacitance (C_{IN}). The frequency f includes driving the load high and then back low.

Example:

In an application where external data memory is used and no other outputs are active, power dissipation is calculated as follows:

Assumptions:

- External data memory is accessed every cycle with 50% of the address pins switching.
- External data memory writes occur every other cycle with 50% of the data pins switching.
- Each address and data pin has a 10 pF total load at the pin.
- The application operates at $V_{DD} = 3.3\text{ V}$ and $t_{CK} = 25\text{ ns}$.

$$\text{Total Power Dissipation} = P_{INT} + (C \times V_{DD}^2 \times f)$$

P_{INT} = internal power dissipation from Power vs. Frequency graphs (Figures 30 and 31).

$(C \times V_{DD}^2 \times f)$ is calculated for each output:

	# of Pins	$\times C$	$\times V_{DD}^2$	$\times f$	=
Address, \overline{DMS}	8	$\times 10\text{ pF}$	$\times 3.3^2\text{ V}$	$\times 40\text{ MHz}$	= 34.8 mW
Data Output, \overline{WR}	9	$\times 10\text{ pF}$	$\times 3.3^2\text{ V}$	$\times 20\text{ MHz}$	= 19.6 mW
\overline{RD}	1	$\times 10\text{ pF}$	$\times 3.3^2\text{ V}$	$\times 40\text{ MHz}$	= 2.2 mW
CLKOUT	1	$\times 10\text{ pF}$	$\times 3.3^2\text{ V}$	$\times 20\text{ MHz}$	= 4.4 mW
					<u>61.0 mW</u>

Total power dissipation for this example is $P_{INT} + 61\text{ mW}$.

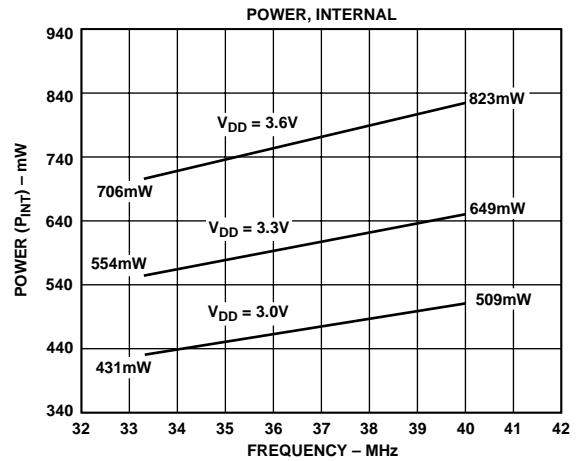

Figure 30. Power vs. Frequency

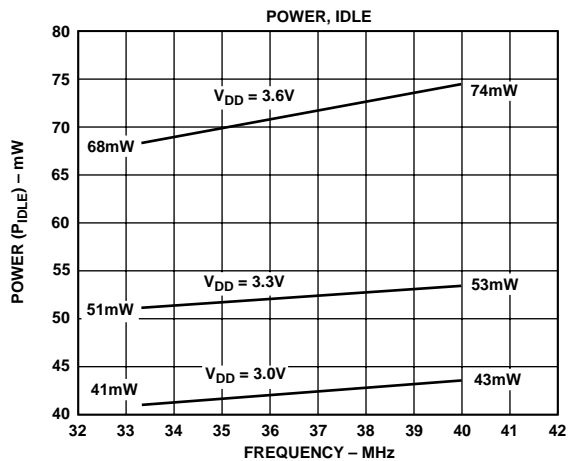

Figure 31. Power vs. Frequency

ADSP-2141L

Pin Configurations

For all multiplexed pins the active sense is determined by the mode selected.

Pin #	Pin Name	Pin #	Pin Name	Pin #	Pin Name	Pin #	Pin Name	Pin #	Pin Name
1	$\overline{\text{EMS}}$	43	PCI_CLK	85	VDD	127	GND	169	GND
2	EE	44	GND	86	GND	128	ADDR[0]	170	DATA[0]
3	GND	45	MPLX_BUS[30]	87	MPLX6	129	ADDR[1]	171	DATA[1]
4	ECLK	46	MPLX_BUS[29]	88	MPLX5	130	ADDR[2]	172	DATA[2]
5	ELOUT	47	MPLX_BUS[28]	89	MPLX_BUS[15]	131	ADDR[3]	173	DATA[3]
6	ELIN	48	MPLX_BUS[27]	90	MPLX_BUS[14]	132	VDD	174	VDD
7	$\overline{\text{EINT}}$	49	VDD	91	MPLX_BUS[13]	133	ADDR[4]	175	GND
8	$\overline{\text{EBR}}$	50	GND	92	MPLX_BUS[12]	134	ADDR[5]	176	DATA[4]
9	$\overline{\text{EBG}}$	51	MPLX_BUS[26]	93	VDD	135	ADDR[6]	177	DATA[5]
10	MMAP	52	MPLX_BUS[25]	94	GND	136	ADDR[7]	178	DATA[6]
11	BMODE	53	MPLX_BUS[24]	95	MPLX_BUS[11]	137	ADDR[8]	179	DATA[7]
12	BUS_MODE	54	MPLX1	96	MPLX_BUS[10]	138	ADDR[9]	180	DATA[8]
13	BUS_SEL	55	MPLX_BUS[23]	97	MPLX_BUS[9]	139	ADDR[10]	181	DATA[9]
14	EE_SK	56	MPLX_BUS[22]	98	MPLX_BUS[8]	140	ADDR[11]	182	DATA[10]
15	EE_CS	57	VDD	99	VDD	141	ADDR[12]	183	DATA[11]
16	EE_DI	58	GND	100	GND	142	ADDR[13]	184	DATA[12]
17	EE_DO	59	MPLX_BUS[21]	101	MPLX4	143	GND	185	DATA[13]
18	VDD	60	MPLX_BUS[20]	102	MPLX_BUS[7]	144	ADDR[14]	186	DATA[14]
19	GND	61	MPLX_BUS[19]	103	MPLX_BUS[6]	145	ADDR[15]	187	DATA[15]
20	PF[7]/ $\overline{\text{INT_H}}$	62	MPLX_BUS[18]	104	MPLX_BUS[5]	146	ADDR[16]	188	VDD
21	PF[6]	63	GND	105	MPLX_BUS[4]	147	ADDR[17]	189	GND
22	PF[5]	64	VDD	106	VDD	148	ADDR[18]	190	DATA[16]
23	PF[4]	65	VDD	107	GND	149	ADDR[19]	191	DATA[17]
24	PF[3]	66	GND	108	MPLX_BUS[3]	150	VDD	192	DATA[18]
25	PF[2]	67	MPLX_BUS[17]	109	MPLX_BUS[2]	151	ADDR[20]	193	DATA[19]
26	PF[1]	68	MPLX_BUS[16]	110	MPLX_BUS[1]	152	ADDR[21]	194	DATA[20]
27	PF[0]	69	MPLX2	111	MPLX_BUS[0]	153	ADDR[22]	195	DATA[21]
28	$\overline{\text{PWD}}$	70	PCI_ $\overline{\text{IRDY}}$	112	GND	154	ADDR[23]	196	VDD
29	$\overline{\text{PVDACK}}$	71	VDD	113	CLKOUT	155	ADDR[24]	197	GND
30	$\overline{\text{BR}}$	72	GND	114	VDD	156	ADDR[25]	198	DATA[22]
31	$\overline{\text{BG}}$	73	PCI_STOP	115	GND	157	DT0	199	DATA[23]
32	$\overline{\text{BGH}}$	74	MPLX10	116	$\overline{\text{WR}}$	158	TFS0	200	DATA[24]
33	$\overline{\text{IRQE}}$	75	MPLX11	117	$\overline{\text{RD}}$	159	RFS0	201	DATA[25]
34	$\overline{\text{IRQL0}}$	76	PCI_PAR	118	$\overline{\text{DMSH}}$	160	DR0	202	DATA[26]
35	$\overline{\text{IRQL1}}$	77	VDD	119	$\overline{\text{DMSL}}$	161	SCLK0	203	DATA[27]
36	$\overline{\text{IRQ2}}$	78	GND	120	$\overline{\text{PMS}}$	162	DT1	204	DATA[28]
37	VDD	79	MPLX3	121	$\overline{\text{BMS}}$	163	TFS1	205	DATA[29]
38	GND	80	MPLX7	122	$\overline{\text{CMS}}$	164	RFS1	206	DATA[30]
39	$\overline{\text{MPLX_RESET}}$	81	MPLX9	123	$\overline{\text{IOMS}}$	164	DR1	207	DATA[31]
40	MPLX12	82	MPLX8	124	VDD	166	SCLK1	208	$\overline{\text{ERESET}}$
41	MPLX_BUS[31]	83	GND	125	CLKIN	167	GND		
42	VDD	84	VDD	126	XTAL	168	VDD		

PINOUT PCI Mode

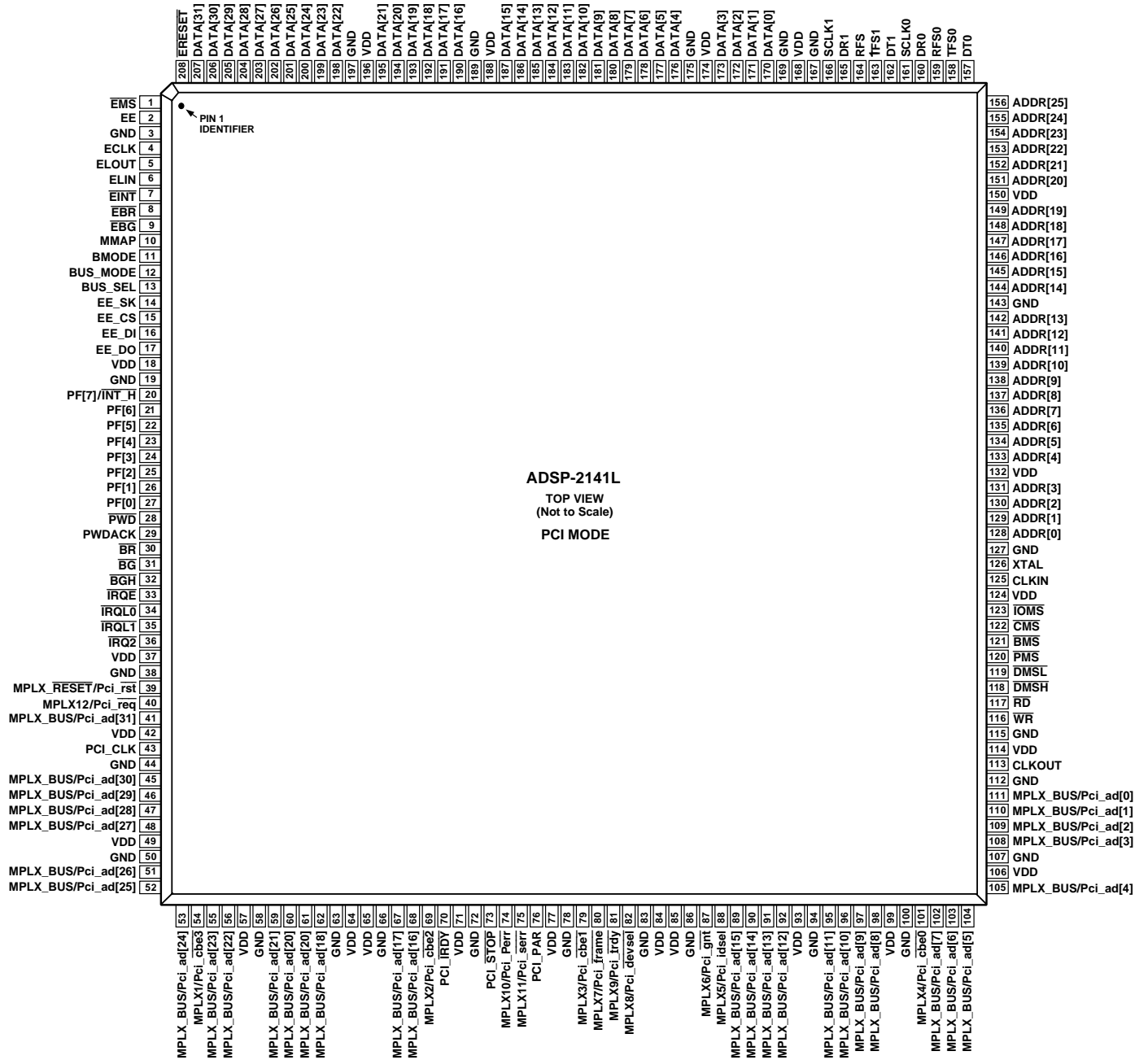

ADSP-2141L

PINOUT 2183-Mode

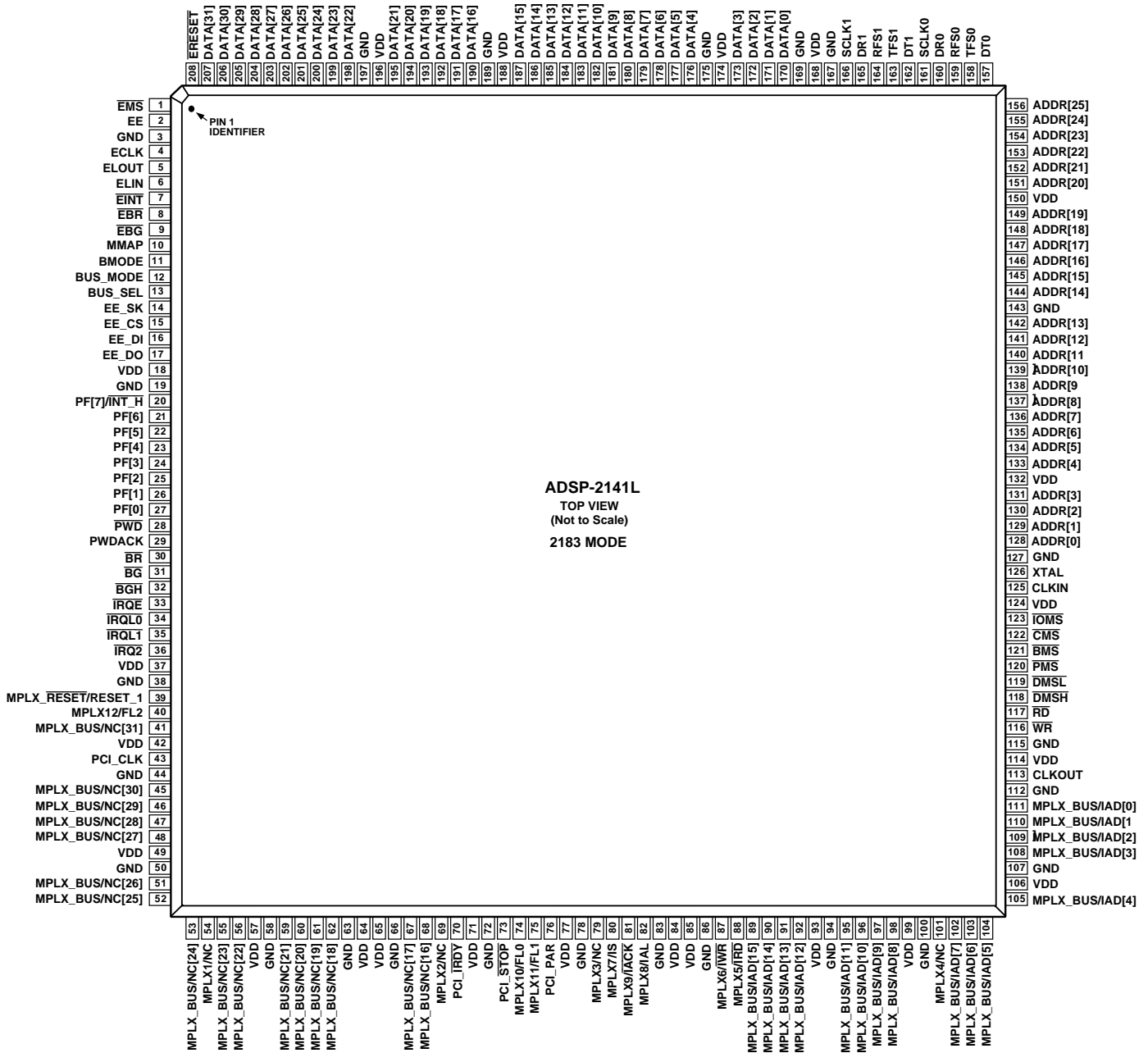

PACKAGE DESCRIPTION

Package Details

The package shown below is a 208-lead metric quad flatpack. Measurements are listed in English and (metric). Because this package is designed as a metric package, Analog Devices recommends that you use these measurements for any PCB layout.

OUTLINE DIMENSIONS

Dimensions shown in inches and (mm).

208-Lead Metric Plastic Quad Flatpack (MQFP) (Nonhermetic)

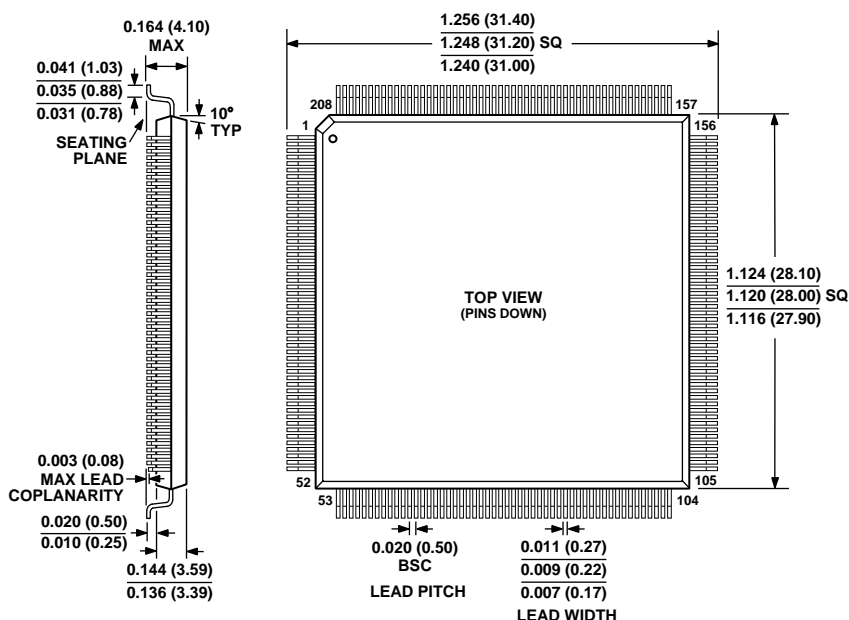

NOTE:
 THE ACTUAL POSITION OF EACH LEAD IS WITHIN 0.003 (0.08) FROM ITS IDEAL POSITION WHEN MEASURED IN THE LATERAL DIRECTION.
 CENTER FIGURES ARE TYPICAL UNLESS OTHERWISE NOTED.
 THE 208 LEAD MQFP IS A METRIC PACKAGE. ENGLISH DIMENSIONS PROVIDED ARE APPROXIMATE AND MUST NOT BE USED FOR BOARD DESIGN PURPOSES

ORDERING GUIDE

Part Number	Ambient Temperature Range	Instruction Rate	Package Description	Package Option
ADSP-2141LKS-N1 ¹	0°C to +70°C	40 MHz	208-Lead MQFP	S-208
ADSP-2141LKS-E1 ²	0°C to +70°C	40 MHz	208-Lead MQFP	S-208

NOTES

¹The ADSP-2141LKS-N1 is an electrically equivalent, full function, production (non x-grade) version of the product described in this data sheet. (Full function = Triple DES enabled, full 168-bit key length, full 2048-bit public key lengths, red keys allowed.)

²The ADSP-2141LKS-E1 is an electrically equivalent, full function, production (non x-grade) version of the product described in this data sheet except for the following:
 Encryption: DES only, with maximum 56-bit key length. Triple DES is disabled.
 Public Key Algorithms: Public Key Algorithms limited to 1024-bit max modulus. Red keys not allowed in hardware crypto context.