

Circuits from the Lab™

Circuits from the Lab™ tested circuit designs address common design challenges and are engineered for quick and easy system integration. For more information and/or support, visit www.analog.com/CN0134.

Devices Connected/Referenced

ADF4350	Fractional-N PLL IC with Integrated VCO
ADL5375	Wideband Transmit Modulator
ADP150	Low Noise 3.3 V LDO
ADP3334	Low Noise Adjustable LDO

Broadband Low Error Vector Magnitude (EVM) Direct Conversion Transmitter

EVALUATION AND DESIGN SUPPORT

Circuit Evaluation Boards

[CN-0134 Evaluation Board \(CFTL-CN0134-EVALZ\)](#)

Design and Integration Files

[Schematics, Layout Files, Bill of Materials](#)

CIRCUIT FUNCTION AND BENEFITS

This circuit is a complete implementation of the analog portion of a broadband direct conversion transmitter (analog baseband in, RF out). RF frequencies from 500 MHz to 4.4 GHz are supported through the use of a PLL with a broadband integrated voltage controlled oscillator (VCO). Harmonic filtering of the LO from the PLL ensures excellent quadrature accuracy.

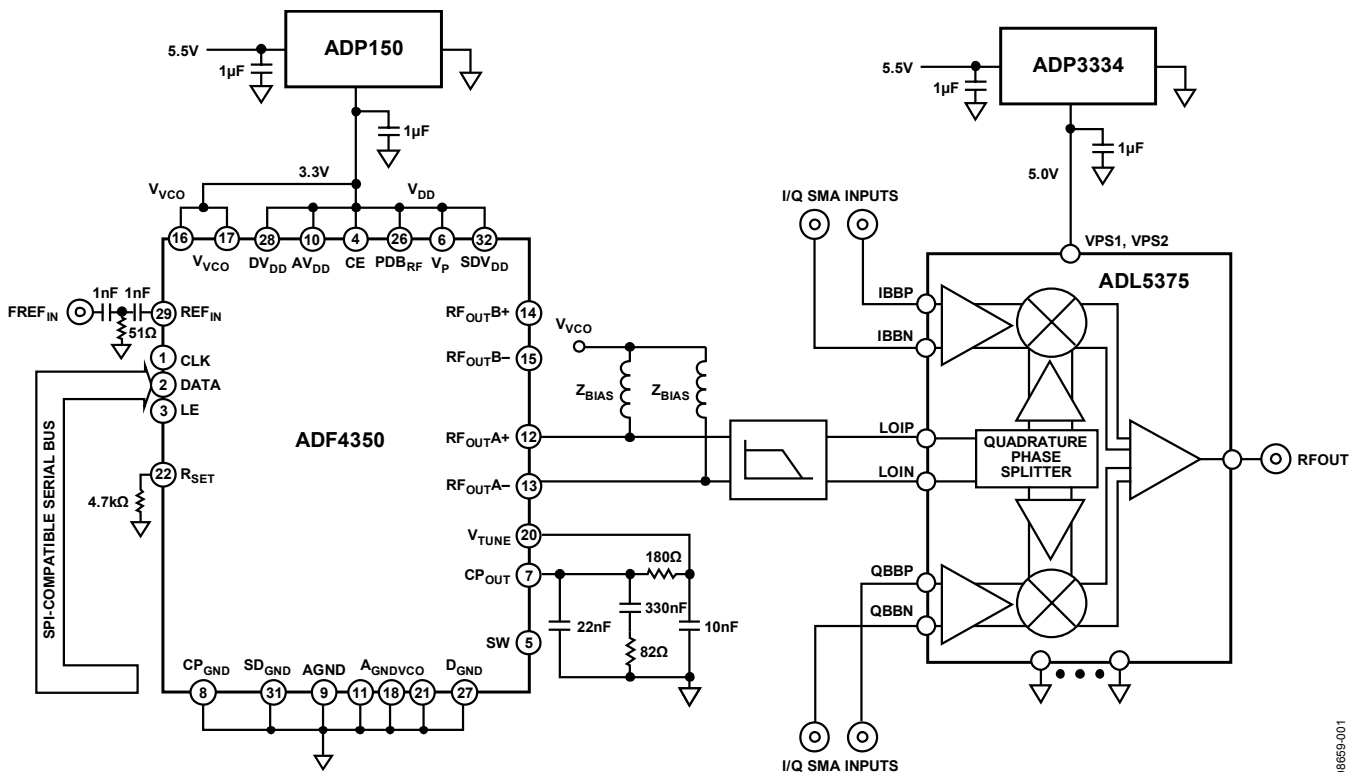

Figure 1. Direct Conversion Transmitter (Simplified Schematic: All Connections and Decoupling Not Shown)

Rev. B

Circuits from the Lab™ circuits from Analog Devices have been designed and built by Analog Devices engineers. Standard engineering practices have been employed in the design and construction of each circuit, and their function and performance have been tested and verified in a lab environment at room temperature. However, you are solely responsible for testing the circuit and determining its suitability and applicability for your use and application. Accordingly, in no event shall Analog Devices be liable for direct, indirect, special, incidental, consequential or punitive damages due to any cause whatsoever connected to the use of any Circuits from the Lab circuits. (Continued on last page)

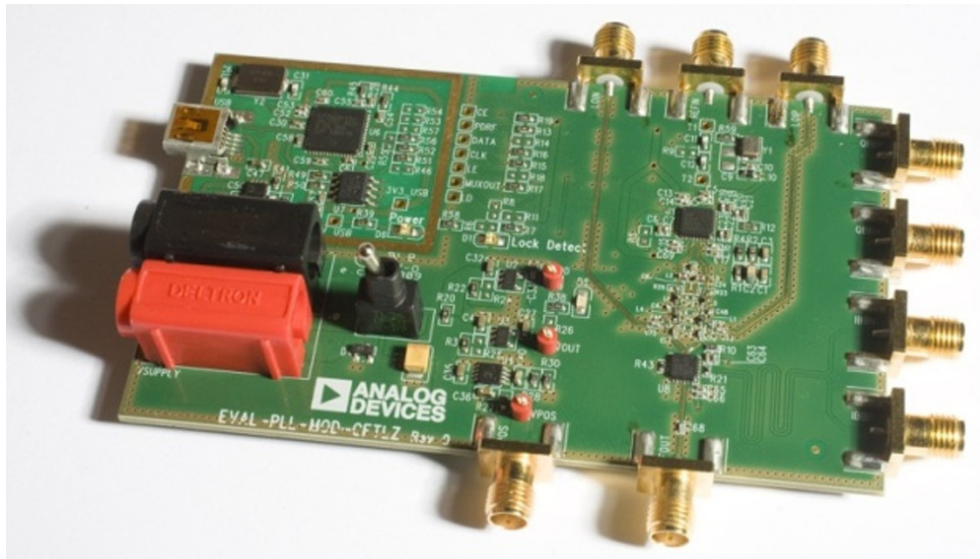

Figure 2. Evaluation Board for CN-0134 Direct Conversion Transmitter

Low noise LDOs ensure that the power management scheme has no adverse impact on phase noise and EVM. This combination of components represents industry-leading direct conversion transmitter performance over a frequency range of 500 MHz to 4.4 GHz

CIRCUIT DESCRIPTION

The circuit shown in Figure 1 utilizes the [ADF4350](#), a fully integrated fractional-N PLL IC, and the [ADL5375](#) wideband transmit modulator. The [ADF4350](#) provides the local oscillator (LO) signal for the [ADL5375](#) transmit quadrature modulator, which upconverts analog I/Q signals to RF. Taken together, the two devices provide a wideband baseband IQ to RF transmit solution. The [ADF4350](#) is powered off the ultralow noise 3.3 V [ADP150](#) regulator for optimal LO phase noise performance. The [ADL5375](#) is powered off a 5 V [ADP3334](#) LDO. The [ADP150](#) LDO has an output voltage noise of only 9 μV rms and helps to optimize VCO phase noise and reduce the impact of VCO pushing (equivalent to power supply rejection).

Filtering is required on the [ADF4350](#) RF outputs to attenuate harmonic levels so as to minimize errors in the quadrature generation block of the [ADL5375](#). From measurement and simulation, the odd order harmonics contribute more than even order harmonics to quadrature error and, if attenuated to below -30 dBc, results in sideband suppression performance of -40 dBc or better. The [ADF4350](#)'s 2nd harmonic (2H) and 3rd harmonic (3H) levels are as given in the data sheet and shown in Table 1. To get the 3rd harmonic below -30 dBc, approximately 20 dB of attenuation is required.

Table 1. ADF4350 RF Output Harmonic Levels Unfiltered

Harmonic Content (Second)	-19 dBc	Fundamental VCO output
Harmonic Content (Third)	-13 dBc	Fundamental VCO output
Harmonic Content (Second)	-20 dBc	Divided VCO output
Harmonic Content (Third)	-10 dBc	Divided VCO output

This circuit gives four different filter options to cover four different bands. The filters were designed for a $100\ \Omega$ differential input ([ADF4350](#) RF outputs with appropriate matching) and $50\ \Omega$ differential output ([ADL5375](#) LOIN differential impedance). A Chebyshev response was used for optimal filter roll-off at the expense of increased pass-band ripple.

The filter schematic is shown in Figure 3. This topology allows the use of either a fully differential filter to minimize component count, a single-ended filter for each output, or a combination of the two. It was determined that for higher frequencies (>2 GHz) two single-ended filters gave the best performance because the series inductor values are twice the value compared to a fully differential filter and, hence, the impact of component parasitics is reduced. For lower frequencies (<2 GHz), a fully differential filter provides adequate results.

Table 2. ADF4350 RF Output Filter Component Values (DNI = Do Not Insert)

Frequency Range (MHz)	Z _{BIAS}	L1 (nH)	L2 (nH)	C1a (pF)	C1c (pF)	C2a (pF)	C2c (pF)	C3a (pF)	C3c (pF)
a. 500–1300	27 nH 50 Ω	3.9	3.9	DNI	4.7	DNI	5.6	DNI	3.3
b. 850–2450	19 nH (100 Ω in position C1c)	2.7	2.7	3.3	100 Ω	4.7	DNI	3.3	DNI
c. 1250–2800	50 Ω	0 Ω	3.6	DNI	DNI	2.2	DNI	1.5	DNI
d. 2800–4400	3.9 nH	0 Ω	0 Ω	DNI	DNI	DNI	DNI	DNI	DNI

The ADF4350 output match consists of the Z_{BIAS} pull-up and, to a lesser extent, the decoupling capacitors on the supply node. To get a broadband match it is recommended to use either a resistive load (Z_{BIAS} = 50 Ω) or a resistive in parallel with a reactive load for Z_{BIAS}. The latter gives slightly higher output power, depending on the inductor chosen. Note that it is possible to place the parallel resistor as a differential component (i.e. 100 Ω) in position C1c to minimize board space. This is done in filter type c, described in Table 2.

The filter should be designed with a cutoff approximately 1.2 to 1.5 times the highest frequency in the band of interest. This allows margin in the design, as typically the cutoff will be lower than designed due to parasitics. The effect of PCB parasitics can be simulated in an EM simulation tool for improved accuracy.

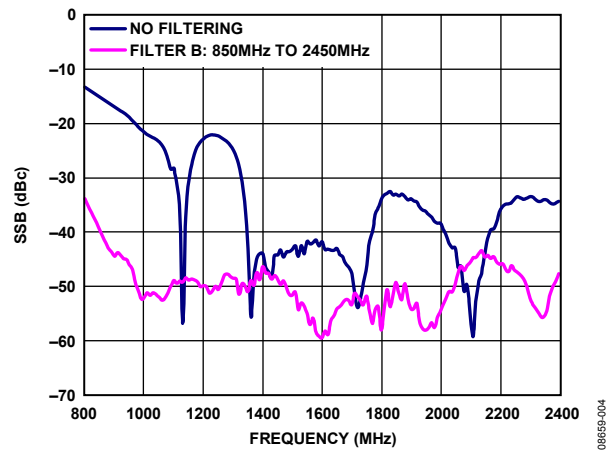

Figure 4. Sideband Suppression for Filter b, 850 MHz to 2450 MHz

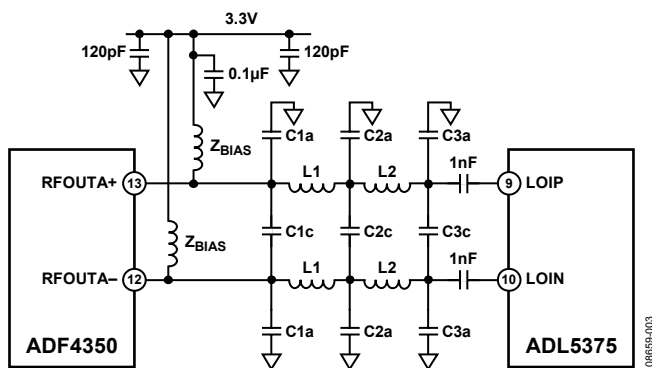

Figure 3. ADF4350 RF Output Filter Schematic

As can be seen from Table 2, at lower frequencies below 1250 MHz, a 5th order filter is required. For 1.25 GHz to 2.8 GHz, 3rd order filtering is sufficient. For frequencies above 2.8 GHz, no filtering is required, as the harmonic levels are sufficiently low to meet sideband suppression specifications.

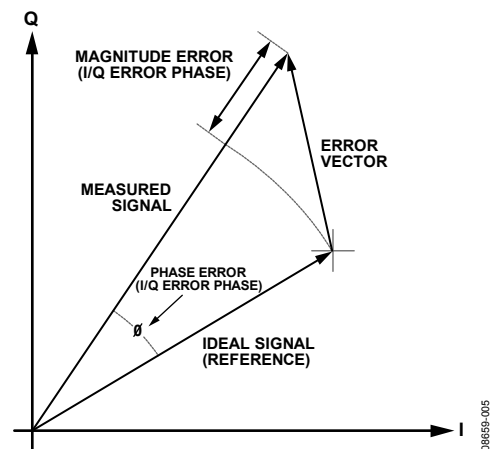

Figure 5. EVM Plot

A sweep of sideband suppression vs. frequency is shown in Figure 4 for the circuit using Filter b (850 MHz to 2450 MHz). In this sweep, the test conditions were the following: baseband I/Q amplitude = 1 V p-p differential sine waves in quadrature with a 500 mV (ADL5375-05) dc bias; baseband I/Q frequency (f_{BB}) = 1 MHz.

Table 3. Single-Carrier W-CDMA Composite EVM Results Comparing Filter vs. No Filter on ADF4350 RF Outputs (Measured As Per 3GPP Specification Test Model 4)

Frequency (MHz)	Composite EVM No LO Filtering	Composite EVM with LO Filtering, Filter C	Modulator Output Power (dBm)
2140	3.50%	1.80%	-7
1800	3.40%	1.50%	-7
900	3.30%	0.90%	-7

Error vector magnitude (EVM) is a measure of the quality of the performance of a digital transmitter or receiver and is a measure of the deviation of the actual constellation points from their ideal locations, due to both magnitude and phase errors. This is shown in Figure 5.

EVM measurements are given in Table 3 comparing results with and without the filter. In this case the baseband I/Q signals were generated using 3GPP test model 4 using a Rhode and Schwarz AMIQ I/Q Modulation Generator with differential I and Q analog outputs. Filter b was also used. A block diagram of the test setup for EVM is given in Figure 6.

Adjacent channel leakage ratio (ACLR) is a measure of the power in adjacent channels relative to the main channel power and is specified in dBc.

The LO phase noise and the linearity of the modulator are the main contributors to ACLR. The ACLR test setup is the same as for EVM with the exception that coaxial filters were placed on the I/Q outputs of the signal generator to reduce aliasing products.

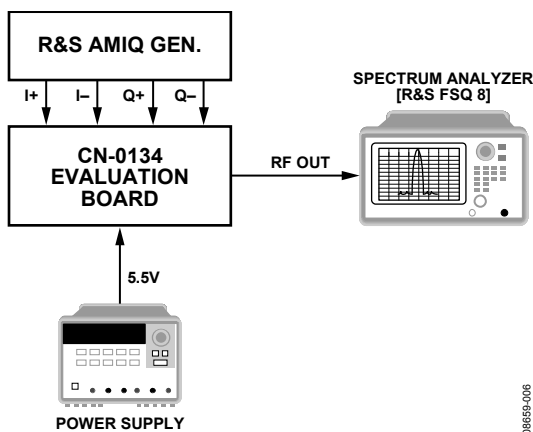

Figure 6. EVM Measurement Setup (Simplified Diagram)

In addition to the improvement in sideband suppression and EVM, there is also a performance benefit to driving the ADL5375 LO inputs differentially. This improves modulator OIP2 performance by 2 dB to 5 dB, compared with single-ended LO drive. Note that most external VCOs only come with a single-ended output, so using the differential outputs on the ADF4350 provides a benefit over an external VCO in this case.

Figure 7 shows sideband suppression results using an 850 MHz to 2450 MHz filter (filter b).

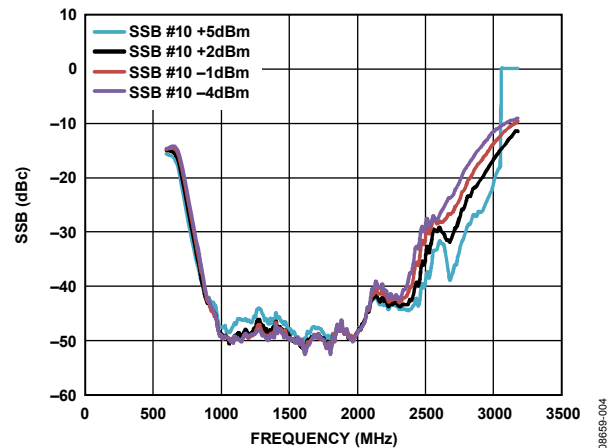

Figure 7. Sideband Suppression Results for 850 MHz to 2450 MHz Filter b

A complete design support package for this circuit note can be found at <http://www.analog.com/CN0134-DesignSupport>.

COMMON VARIATIONS

It is possible to use the auxiliary outputs on the ADF4350 to switch between two filter types where wideband operation beyond that possible with one single filter is required. This is shown in Figure 8. An RF double-pole, 4-throw switch (DP4T) is used to select the differential outputs of either Filter 1 or Filter 2.

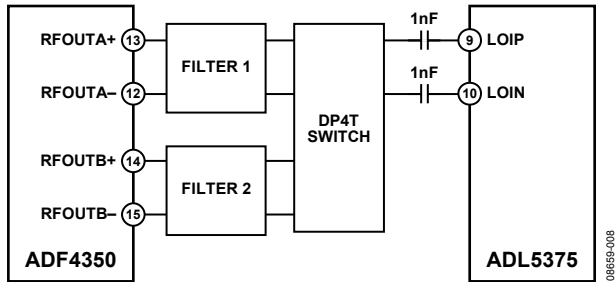

Figure 8. Application Diagram Showing Possibility of Filter Switching Using the ADF4350 Main and Auxiliary Outputs

CIRCUIT EVALUATION AND TEST

The CFTL-0134-EVALZ evaluation board contains the circuit described in circuit note CN-0134, allowing for the quick setup and evaluation of the circuit's performance. The control software for the CFTL-0134-EVALZ board uses the standard ADF4350 programming software, located on the CD that accompanies the evaluation board.

Equipment Needed

A standard PC running Windows® XP, Windows Vista (32-bit), or Windows 7 (32-bit) with USB port, the CFTL-0134-EVALZ circuit evaluation board, and the ADF4350 programming software, power supplies, I-Q signal source, such as a Rhode & Schwarz AMIQ, and a spectrum analyzer such as the Rhode & Schwarz FSQ8. For additional details see the evaluation guide (CN0134-EvalGuide-RevA.pdf), which is contained in the design support package (<http://www.analog.com/CN0134-DesignSupport>), and the ADF4350 and ADL5375 data sheets.

Getting Started

See CN0134-EvalGuide-RevA.pdf for software installation and test setup. The documentation also includes the block diagram, the application schematic, the bill of materials, and the layout and assembly information. Also see the AD4350 and ADL5375 data sheets for additional details.

Functional Block Diagram

See Figure 1 and Figure 6 in circuit note CN-0134 and the CN0134-EvalGuide-RevA.pdf, Wideband TX Modulator Solution user document in the design support package.

Setup and Test

See circuit note CN-0134 and the CN0134-EvalGuide-RevA.pdf, Wideband TX Modulator Solution user document,

for software installation and test setup. Also see the AD4350 and ADL5375 data sheets for additional details.

LEARN MORE

CN0134 Design Support Package:

<http://www.analog.com/CN0134-DesignSupport>

ADIsimPLL Design Tool

ADIsimPower Design Tool

ADIsimRF Design Tool

AN-0996 Application Note. *The Advantages of Using a Quadrature Digital Upconverter (QDUC) in Point-to-Point Microwave Transmit Systems*. Analog Devices.

AN-1039 Application Note. *Correcting Imperfections in IQ Modulators to Improve RF Signal Fidelity*. Analog Devices.

Data Sheets and Evaluation Boards

[ADF4350 Data Sheet](#)

[ADF4350 Evaluation Board](#)

[ADL5375 Data Sheet](#)

[ADL5375 Evaluation Board](#)

[ADP150 Data Sheet](#)

[ADP3334 Data Sheet](#)

REVISION HISTORY

11/10—Rev. A to Rev. B

Changes to Circuit Note Title.....	1
Added Evaluation and Design Support Section.....	1
Changes to Circuit Description Section.....	2
Changes to Figure 6	4
Added Circuit Evaluation and Test Section.....	5

9/10—Rev. 0 to Rev. A

Changes to Circuit Note Title.....	1
Changes to Circuit Function and Benefits Section.....	1
Changes to Circuit Description Section.....	2
Changes to Common Variations Section.....	4

1/10—Revision 0: Initial Version

(Continued from first page) Circuits from the Lab circuits are intended only for use with Analog Devices products and are the intellectual property of Analog Devices or its licensors. While you may use the Circuits from the Lab circuits in the design of your product, no other license is granted by implication or otherwise under any patents or other intellectual property by application or use of the Circuits from the Lab circuits. Information furnished by Analog Devices is believed to be accurate and reliable. However, "Circuits from the Lab" are supplied "as is" and without warranties of any kind, express, implied, or statutory including, but not limited to, any implied warranty of merchantability, noninfringement or fitness for a particular purpose and no responsibility is assumed by Analog Devices for their use, nor for any infringements of patents or other rights of third parties that may result from their use. Analog Devices reserves the right to change any Circuits from the Lab circuits at any time without notice but is under no obligation to do so.