

## FEATURES

**Tiny 3.35 mm × 2.50 mm × 0.88 mm surface-mount package**  
**High SNR of 62 dBA**  
**High sensitivity of –38 dBV**  
**Flat frequency response from 200 Hz to 15 kHz**  
**Low current consumption: <250 μA**  
**Single-ended analog output**  
**High PSRR of 70 dB**  
**Compatible with Sn/Pb and Pb-free solder processes**  
**RoHS/WEEE compliant**

## APPLICATIONS

**Smartphones and feature phones**  
**Digital video cameras**  
**Bluetooth headsets**  
**Video phones**  
**Teleconferencing systems**

## GENERAL DESCRIPTION

The ADMP405 is a high quality, low cost, low power, analog output bottom-ported omnidirectional MEMS microphone. The ADMP405 consists of a MEMS microphone element, an impedance converter, and an output amplifier. The ADMP405 sensitivity specification makes it an excellent choice for both near field and far field applications. The ADMP405 has a high SNR and flat, wideband frequency response, resulting in natural sound with high intelligibility. The specially designed low-frequency cutoff reduces wind noise. Low current consumption enables long battery life for portable applications. A built-in particle filter provides high reliability. The ADMP405 complies with the TIA-920 *Telecommunications Telephone Terminal Equipment Transmission Requirements for Wideband Digital Wireline Telephones* standard.

The ADMP405 is available in an ultraminiature 3.35 mm × 2.50 mm × 0.88 mm surface-mount package. It is reflow solder compatible with no sensitivity degradation. The ADMP405 is halide free.

## FUNCTIONAL BLOCK DIAGRAM

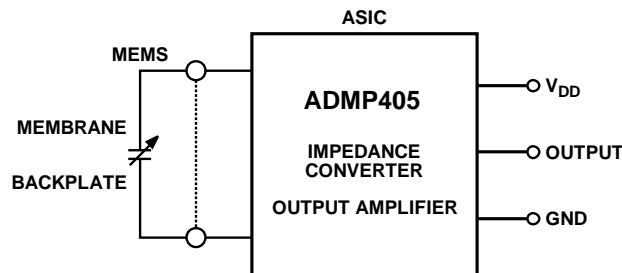

Figure 1.

### Rev. PrH

Information furnished by Analog Devices is believed to be accurate and reliable. However, no responsibility is assumed by Analog Devices for its use, nor for any infringements of patents or other rights of third parties that may result from its use. Specifications subject to change without notice. No license is granted by implication or otherwise under any patent or patent rights of Analog Devices. Trademarks and registered trademarks are the property of their respective owners.

**TABLE OF CONTENTS**

Features .....	1	Connecting the ADMP405 to a Codec .....	7
Applications.....	1	Connecting the ADMP405 to an Op Amp Gain Stage .....	7
General Description .....	1	PCB Land Pattern Layout.....	8
Functional Block Diagram .....	1	Handling Instructions.....	9
Revision History .....	2	Pick and Place Equipment.....	9
Specifications.....	3	Reflow Solder .....	9
Absolute Maximum Ratings.....	4	Board Wash .....	9
ESD Caution.....	4	Reliability Specifications.....	10
Pin Configuration and Function Descriptions.....	5	Outline Dimensions .....	11
Typical Performance Characteristics .....	6	Ordering Guide .....	11
Applications Information .....	7		

**REVISION HISTORY**

## SPECIFICATIONS

$T_A = 25^\circ\text{C}$ ,  $V_{DD} = 1.8\text{ V}$ , unless otherwise noted. All minimum and maximum specifications are guaranteed. Typical specifications are not guaranteed.

**Table 1.**

Parameter	Symbol	Test Conditions/Comments	Min	Typ	Max	Unit
<b>PERFORMANCE</b>						
Directionality				Omni		
Sensitivity		1 kHz, 94 dB SPL	-41	-38	-35	dBV
Signal-to-Noise Ratio	SNR			62		dBA
Equivalent Input Noise	EIN			32		dBA SPL
Frequency Response <sup>1</sup>		Low frequency -3 dB point		200		Hz
		High frequency -3 dB point		15		kHz
		Deviation from flat response within pass band	-3		+2	dB
Total Harmonic Distortion	THD	105 dB SPL			3	%
Power Supply Rejection Ratio	PSRR	217 Hz, 100 mV p-p square wave superimposed on $V_{DD} = 1.8\text{ V}$		70		dB
Maximum Acoustic Input		Peak		120		dB SPL
<b>POWER SUPPLY</b>						
Supply Voltage	$V_{DD}$		1.5		3.6	V
Supply Current	$I_S$				250	$\mu\text{A}$
<b>OUTPUT CHARACTERISTICS</b>						
Output impedance	$Z_{OUT}$			200		$\Omega$
Output DC Offset				0.8		V
Output Current Limit				90		$\mu\text{A}$
Polarity				Noninverting <sup>2</sup>		

<sup>1</sup> See Figure 4 and Figure 6.

<sup>2</sup> Positive going (increasing) pressure on the membrane results in a positive going (increasing) output voltage.

## ABSOLUTE MAXIMUM RATINGS

Table 2.

Parameter	Rating
Supply Voltage	3.6V
Sound Pressure Level (SPL)	160 dB
Mechanical Shock	10,000 g
Vibration	Per MIL-STD-883 Method 2007, Test Condition B
Temperature Range	-40°C to +70°C

Stresses above those listed under Absolute Maximum Ratings may cause permanent damage to the device. This is a stress rating only; functional operation of the device at these or any other conditions above those indicated in the operational section of this specification is not implied. Exposure to absolute maximum rating conditions for extended periods may affect device reliability.

### ESD CAUTION



**ESD (electrostatic discharge) sensitive device.** Charged devices and circuit boards can discharge without detection. Although this product features patented or proprietary protection circuitry, damage may occur on devices subjected to high energy ESD. Therefore, proper ESD precautions should be taken to avoid performance degradation or loss of functionality.

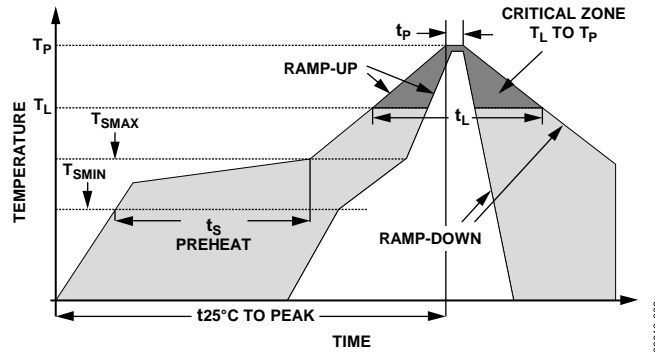
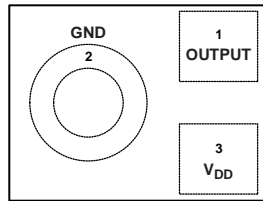

Figure 2. Recommended Soldering Profile Limits

Table 3. Recommended Soldering Profile Limits

Profile Feature	Sn63/Pb37	Pb-Free
Average Ramp Rate ( $T_L$ to $T_P$ )	3°C/sec max	3°C/sec max
Preheat		
Minimum Temperature ( $T_{SMIN}$ )	100°C	150°C
Maximum Temperature ( $T_{SMAX}$ )	150°C	200°C
Time ( $T_{SMIN}$ to $T_{SMAX}$ ), $t_S$	60 sec to 120 sec	60 sec to 120 sec
Ramp-Up Rate ( $T_{SMAX}$ to $T_L$ )	3°C/sec	3°C/sec
Time Maintained Above Liquidous ( $t_L$ )	60 sec to 150 sec	60 sec to 150 sec
Liquidous Temperature ( $T_L$ )	183°C	217°C
Peak Temperature ( $T_P$ )	240°C + 0°C/-5°C	260°C + 0°C/-5°C
Time Within 5°C of Actual Peak Temperature ( $t_P$ )	10 sec to 30 sec	20 sec to 40 sec
Ramp-Down Rate	6°C/sec max	6°C/sec max
Time 25°C ( $t_{25^{\circ}\text{C}}$ ) to Peak Temperature	6 minute max	8 minute max

## PIN CONFIGURATION AND FUNCTION DESCRIPTIONS



TOP VIEW  
(TERMINAL SIDE DOWN)  
Not to Scale

08616-003

Figure 3. Pin Configuration

Table 4. Pin Function Descriptions

Pin No.	Mnemonic	Description
1	OUTPUT	Analog Output Signal.
2	GND	Ground.
3	V <sub>DD</sub>	Power Supply.

### TYPICAL PERFORMANCE CHARACTERISTICS

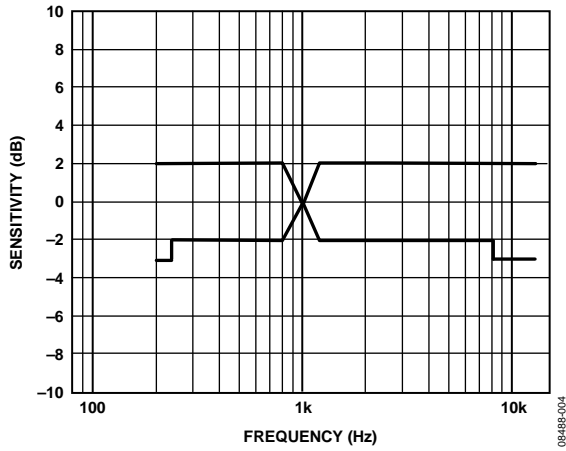

Figure 4. Frequency Response Mask

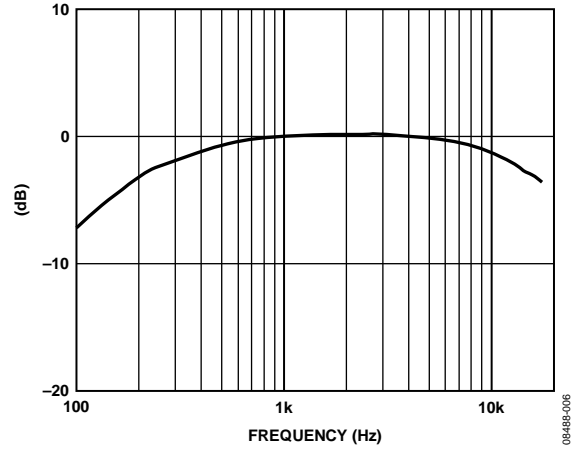

Figure 6. Typical Frequency Response (Measured)

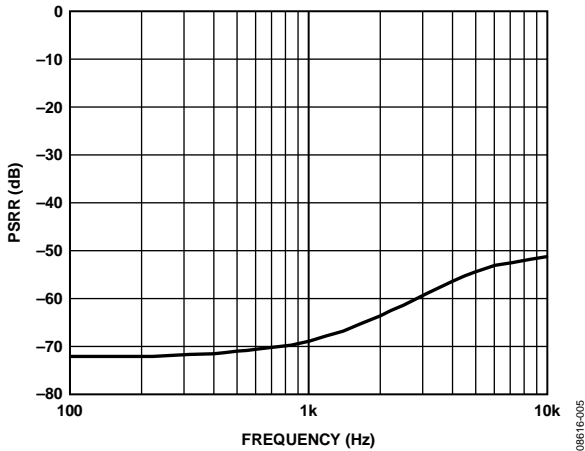

Figure 5. Typical Power Supply Rejection Ratio vs. Frequency

## APPLICATIONS INFORMATION

The ADMP405 output can be connected to a dedicated codec microphone input (see Figure 7) or to a high input impedance gain stage (see Figure 8). A 0.1 μF ceramic capacitor (C1) at V<sub>DD</sub> placed close to the ADMP405 supply pins is used for testing and is recommended to adequately decouple the microphone from noise on the power supply. A 1 μF or larger dc-blocking tantalum capacitor (C2) is required at the output of the microphone.

### CONNECTING THE ADMP405 TO A CODEC

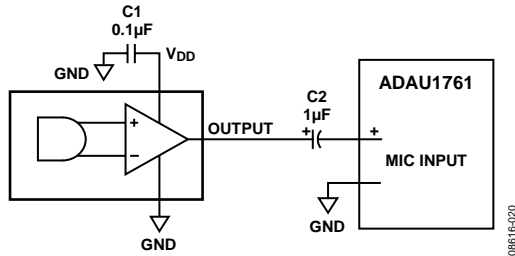

Figure 7. ADMP405 Connected to the Analog Devices [ADAU1761](#) Codec

### CONNECTING THE ADMP405 TO AN OP AMP GAIN STAGE

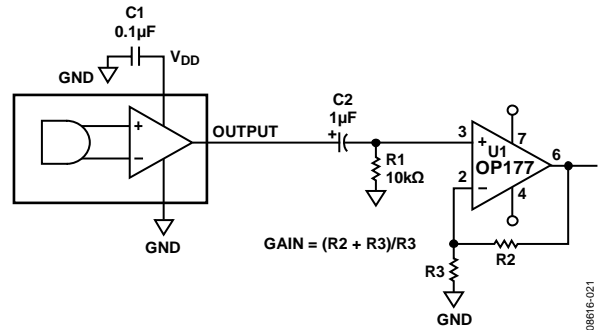

Figure 8. ADMP405 Connected to the [OP177](#) Op Amp

### PCB LAND PATTERN LAYOUT

The recommended PCB land pattern for the ADMP405 should be laid out to a 1:1 ratio to the solder pads on the microphone package, as shown in Figure 9. Care should be taken to avoid applying solder paste to the sound hole in the PCB. A suggested

solder paste stencil pattern layout is shown in Figure 10. The diameter of the sound hole in the PCB should be larger than the diameter of the sound port of the microphone. A minimum diameter of 0.5 mm is recommended.

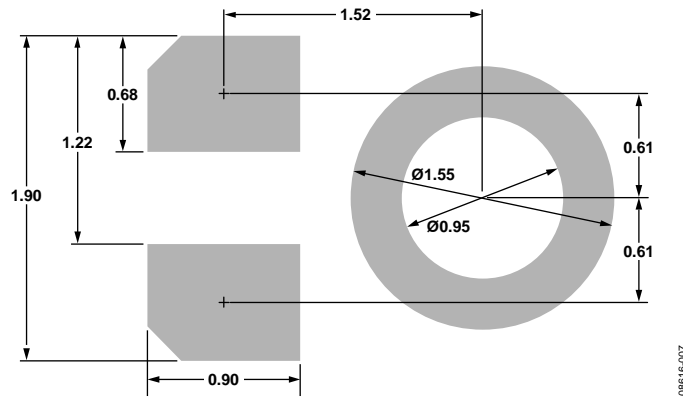

Figure 9. PCB Land Pattern Layout

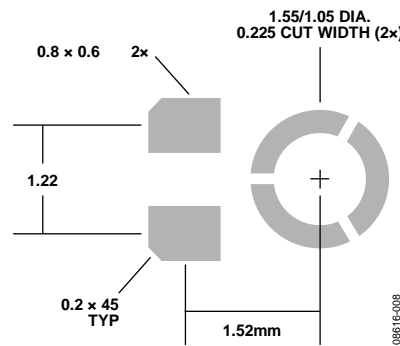

Figure 10. Suggested Solder Paste Stencil Pattern Layout



## **HANDLING INSTRUCTIONS**

### **PICK AND PLACE EQUIPMENT**

The MEMS microphone can be handled using standard pick-and-place and chip shooting equipment. Care should be taken to avoid damage to the MEMS microphone structure as follows:

- Use a standard pickup tool to handle the microphone. Because the microphone hole is on the bottom of the package, the pickup tool can make contact with any part of the lid surface.
- Use care during pick-and-place to ensure that no high shock events above 20 kg are experienced because such events may cause damage to the microphone.
- Do not pick up the microphone with a vacuum tool that makes contact with the bottom side of the microphone. Do not pull air out of or blow air into the microphone port.
- Do not use excessive force to place the microphone on the PCB.

### **REFLOW SOLDER**

For best results, the soldering profile should be in accordance with the recommendations of the manufacturer of the solder paste used to attach the MEMS microphone to the PCB. It is recommended that the solder reflow profile not exceed the limit conditions specified in Figure 2 and Table 3.

### **BOARD WASH**

When washing the PCB, ensure that water does not make contact with the microphone port. Blow-off procedures and ultrasonic cleaning must not be used.

## RELIABILITY SPECIFICATIONS

The microphone sensitivity after stress must deviate by no more than  $\pm 3$  dB from the initial value.

Table 5.

Stress Test	Description
Low Temperature Operating Life	-40°C, 500 hours, powered
High Temperature Operating Life	+125°C, 500 hours, powered
THB	+65°C/85% relative humidity (RH), 500 hours, powered
Temperature Cycle	-40°C/+125°C, one cycle per hours, 100 cycles
High Temperature Storage	+150°C, 500 hours
Low Temperature Storage	-40°C, 500 hours
Component CDM ESD	All pins, 0.5 kV
Component HBM ESD	All pins, 1.5 kV
Component MM ESD	All pins, 0.2 kV

# OUTLINE DIMENSIONS

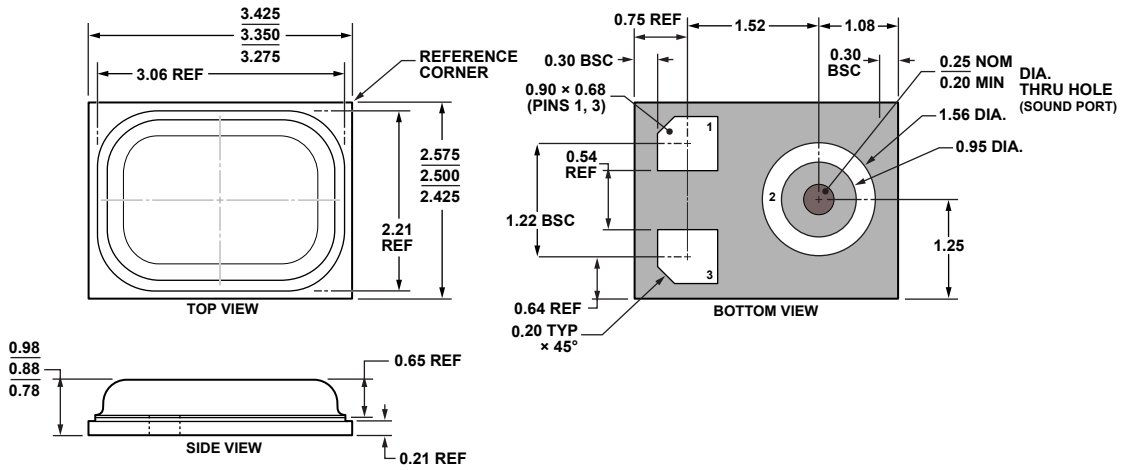

03-12-2010-A

## ORDERING GUIDE

Model <sup>1</sup>	Temperature Range	Package Description	Package Option	Ordering Quantity
ADMP405ACEZ	-40°C to +70°C	3-Terminal LGA_CAV	CE-3-2 <sup>2</sup>	1
ADMP405ACEZ-RL	-40°C to +70°C	3-Terminal LGA_CAV, 13" Tape and Reel	CE-3-2 <sup>2</sup>	10,000
ADMP405ACEZ-RL7	-40°C to +70°C	3-Terminal LGA_CAV, 7" Tape and Reel	CE-3-2 <sup>2</sup>	1,000
EVAL-ADMP405Z		Evaluation Board		

<sup>1</sup> Z = RoHS Compliant Part.

<sup>2</sup> This package option is halide free.

**NOTES**