

### FEATURES

- Complete supervisory and sequencing solution for up to 10 supplies**
- 10 supply fault detectors enable supervision of supplies to better than 1% accuracy**
- 5 selectable input attenuators allow supervision of supplies up to 14.4 V on VH, 6 V on VP1 to VP4**
- 5 dual-function inputs, VX1 to VX5**
  - High impedance input to supply fault detector with thresholds between 0.573 V and 1.375 V
  - General-purpose logic input
- 10 programmable output drivers, PDO1 to PDO10**
  - Open collector with external pull-up
  - Push/pull output, driven to VDDCAP or VPn
  - Open collector with weak pull-up to VDDCAP or VPn
  - Internally charge-pumped high drive for use with external N-FET (PDO1 to PDO6 only)
- Sequencing engine (SE) implements state machine control of PDO outputs**
  - State changes conditional on input events
  - Enables complex control of boards
  - Power-up and power-down sequence control
  - Fault event handling
  - Interrupt generation on warnings
  - Watchdog function can be integrated in SE
  - Program software control of sequencing through SMBus
- Complete voltage margining solution for 6 voltage rails**
- 6 voltage output, 8-bit DACs (0.300 V to 1.551 V) allow voltage adjustment via dc-to-dc converter trim/feedback node**
- 12-bit ADC for readback of all supervised voltages**
- 1 internal and 2 external temperature sensors**
- Reference input, REFIN, has 2 input options**
  - Driven directly from 2.048 V ( $\pm 0.25\%$ ) REFOUT pin
  - More accurate external reference for improved ADC performance
- Device powered by the highest of VP1 to VP4, VH for improved redundancy**
- User EEPROM: 256 bytes**
- Industry-standard, 2-wire bus interface (SMBus)**
- Guaranteed PDO low with VH, VPn = 1.2 V**
- 40-lead, 6 mm  $\times$  6 mm LFCSP and 48-lead, 7 mm  $\times$  7 mm TQFP packages**

### FUNCTIONAL BLOCK DIAGRAM

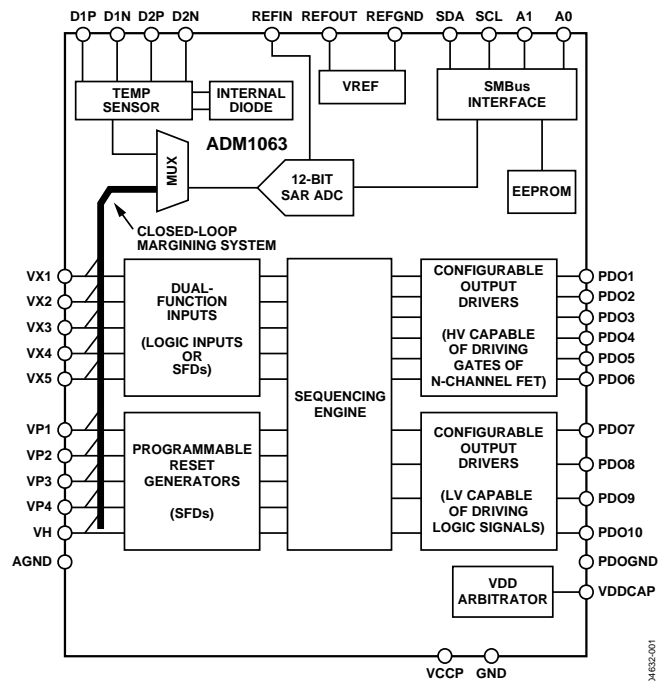

Figure 1.

### APPLICATIONS

- Central office systems
- Servers/routers
- Multivoltage system line cards
- DSP/FPGA supply sequencing
- In-circuit testing of margined supplies

### GENERAL DESCRIPTION

The ADM1063 is a configurable supervisory/sequencing device that offers a single-chip solution for supply monitoring and sequencing in multiple supply systems. In addition to these functions, the ADM1063 integrates a 12-bit ADC and six 8-bit voltage output DACs. These circuits can be used to implement a closed-loop margining system, which enables supply adjustment by altering either the feedback node or reference of a dc-to-dc converter using the DAC outputs.

(continued on Page 3)

### Rev. 0

Information furnished by Analog Devices is believed to be accurate and reliable. However, no responsibility is assumed by Analog Devices for its use, nor for any infringements of patents or other rights of third parties that may result from its use. Specifications subject to change without notice. No license is granted by implication or otherwise under any patent or patent rights of Analog Devices. Trademarks and registered trademarks are the property of their respective owners.

**TABLE OF CONTENTS**

General Description .....	3	Fault Reporting .....	19
Specifications.....	4	Voltage Readback.....	20
Pin Configurations and Function Descriptions .....	7	Supply Supervision with the ADC.....	20
Absolute Maximum Ratings.....	8	Supply Margining .....	21
Thermal Characteristics .....	8	Overview .....	21
ESD Caution.....	8	Open-Loop Margining .....	21
Typical Performance Characteristics .....	9	Closed-Loop Supply Margining .....	21
Powering the ADM1063 .....	12	Writing to the DACs .....	22
Inputs.....	13	Choosing the Size of the Attenuation Resistor .....	22
Supply Supervision.....	13	DAC Limiting and Other Safety Features .....	22
Programming the Supply Fault Detectors.....	13	Temperature Measurement System.....	23
Input Comparator Hysteresis.....	14	Remote Temperature Measurement .....	23
Input Glitch Filtering .....	14	Applications Diagram .....	25
Supply Supervision with VXn Inputs .....	14	Communicating with the ADM1063.....	26
VXn Pins as Digital Inputs.....	15	Configuration Download at Power-Up.....	26
Outputs .....	16	Updating the Configuration .....	26
Supply Sequencing Through Configurable		Updating the Sequencing Engine.....	27
Output Drivers.....	16	Internal Registers.....	27
Sequencing Engine .....	17	EEPROM .....	27
Overview.....	17	Serial Bus Interface.....	27
Warnings.....	17	SMBus Protocols for RAM and EEPROM.....	29
SMBus Jump (Unconditional Jump).....	17	Write Operations .....	29
Sequencing Engine Application Example .....	18	Read Operations.....	31
Sequence Detector .....	19	Outline Dimensions .....	33
Monitoring Fault Detector .....	19	Ordering Guide .....	34
Timeout Detector .....	19		

**REVISION HISTORY**

4/05—Revision 0: Initial Version

## GENERAL DESCRIPTION

(continued from Page 1)

Supply margining can be performed with a minimum of external components. The margining loop can be used for in-circuit testing of a board during production (for example, to verify the board's functionality at -5% of nominal supplies), or it can be used dynamically to accurately control the output voltage of a dc-to-dc converter.

The device also provides up to 10 programmable inputs for monitoring under, over, or out-of-window faults on up to 10 supplies. In addition, 10 programmable outputs can be used as logic enables. Six of these programmable outputs can provide up to a 12 V output for driving the gate of an N-channel FET, which can be placed in the path of a supply.

Temperature measurement is possible with the ADM1063. The device contains one internal temperature sensor and two pairs of differential inputs for remote thermal diodes. These are measured by the 12-bit ADC.

The logical core of the device is a sequencing engine. This state-machine-based construction provides up to 63 different states. This design enables very flexible sequencing of the outputs, based on the condition of the inputs.

The device is controlled via configuration data that can be programmed into an EEPROM. The entire configuration can be programmed using an intuitive GUI-based software package provided by ADI.

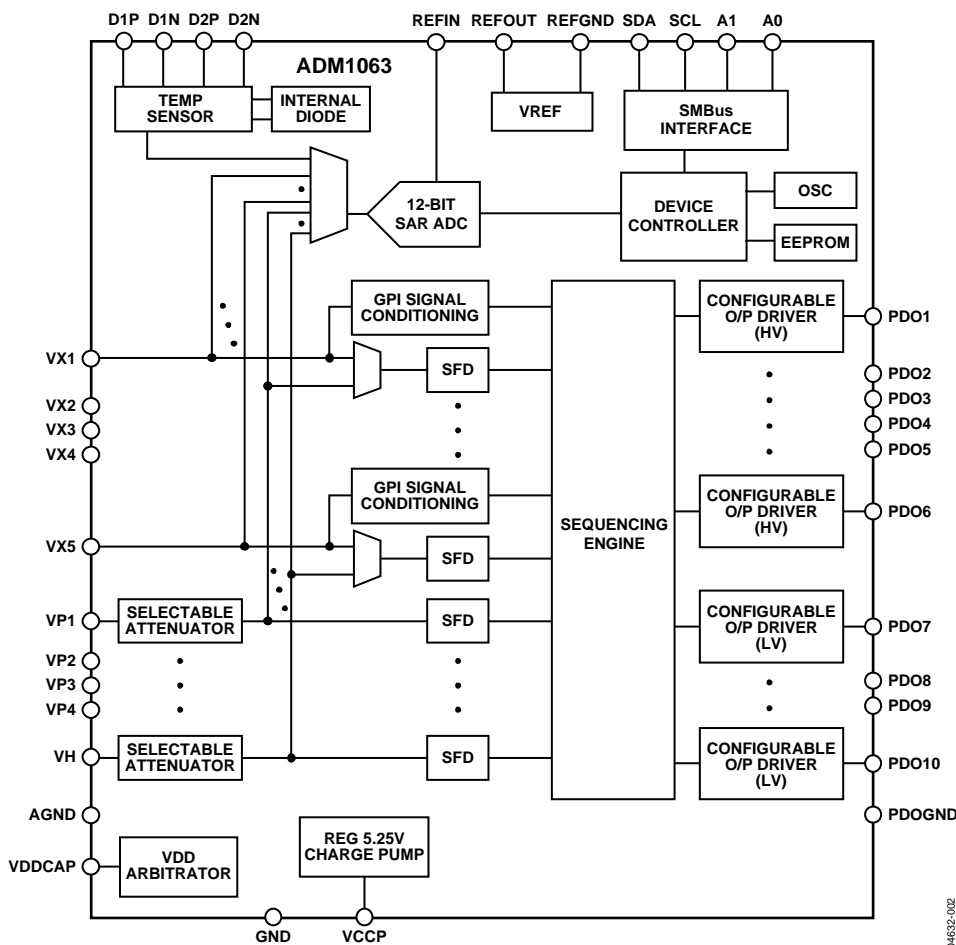

Figure 2. Detailed Block Diagram

# ADM1063

## SPECIFICATIONS

VH = 3.0 V to 14.4 V<sup>1</sup>, VPn = 3.0 V to 6.0 V<sup>1</sup>, TA = -40°C to +85°C, unless otherwise noted.

Table 1.

Parameter	Min	Typ	Max	Unit	Test Conditions/Comments
<b>POWER SUPPLY ARBITRATION</b>					
VH, VPn	3.0			V	Minimum supply required on one of VH, VPn.
VP			6.0	V	Maximum VDDCAP = 5.1 V, typical.
VH			14.4	V	VDDCAP = 4.75 V.
VDDCAP	2.7	4.75	5.4	V	Regulated LDO output.
C <sub>VDDCAP</sub>	10			μF	Minimum recommended decoupling capacitance.
<b>POWER SUPPLY</b>					
Supply Current, I <sub>VH</sub> , I <sub>VPn</sub>		4.2	6	mA	VDDCAP = 4.75 V, PDO1 to PDO10 off, DACs off, ADC off.
Additional Currents					
All PDO FET Drivers On		1		mA	VDDCAP = 4.75 V, PDO1 to PDO6 loaded with 1 μA each, PDO7 to PDO10 off.
Current Available from VDDCAP			2	mA	Maximum additional load that can be drawn from all PDO pull-ups to VDDCAP.
DACs Supply Current		2.2		mA	Six DACs on with 100 μA maximum load on each.
ADC Supply Current		1		mA	Running round-robin loop.
EEPROM Erase Current		10		mA	1 ms duration only, VDDCAP = 3 V.
<b>SUPPLY FAULT DETECTORS</b>					
VH Pin					
Input Attenuator Error		±0.05		%	Midrange and high range.
Detection Ranges					
High Range	6		14.4	V	
Midrange	2.5		6	V	
VPn Pins					
Input Attenuator Error		±0.05		%	Low range and midrange.
Detection Ranges					
Midrange	2.5		6	V	
Low Range	1.25		3	V	
Ultralow Range	0.573		1.375	V	No input attenuation error.
VXn Pins					
Input Impedance	1			MΩ	
Detection Range					
Ultralow Range	0.573		1.375	V	No input attenuation error.
Absolute Accuracy			±1	%	VREF error + DAC nonlinearity + comparator offset error + input attenuation error.
Threshold Resolution		8		Bits	
Digital Glitch Filter					
		0		μs	Minimum programmable filter length.
		100		μs	Maximum programmable filter length.
<b>ANALOG-TO-DIGITAL CONVERTER</b>					
Signal Range	0		V <sub>REFIN</sub>	V	The ADC can convert signals presented to the VH, VPn, and VXn pins. VPn and VH input signals are attenuated depending on selected range. A signal at the pin corresponding to the selected range is from 0.573 V to 1.375 V at the ADC input.
Input Reference Voltage on REFIN Pin, V <sub>REFIN</sub>		2.048		V	
Resolution		12		Bits	
INL			±2.5	LSB	Endpoint corrected, V <sub>REFIN</sub> = 2.048 V.
Gain Error			±0.05	%	V <sub>REFIN</sub> = 2.048 V.

Parameter	Min	Typ	Max	Unit	Test Conditions/Comments
Conversion Time		0.44		ms	One conversion on one channel
Offset Error		84		ms	All 12 channels selected, 16x averaging enabled
Input Noise			±2	LSB	V <sub>REFIN</sub> = 2.048 V
		0.25		LSB <sub>rms</sub>	Direct input (no attenuator)
<b>TEMPERATURE SENSOR<sup>2</sup></b>					
Local Sensor Accuracy		±3		°C	VDDCAP = 4.75 V
Local Sensor Supply Voltage Coefficient		-1.7		°C/V	
Remote Sensor Accuracy		±3		°C	VDDCAP = 4.75 V
Remote Sensor Supply Voltage Coefficient		-3		°C	
Remote Sensor Current Source		200		µA	High level
		12		µA	Low level
Temperature for Code 0x800		0		°C	VDDCAP = 4.75 V
Temperature for Code 0xC00		128		°C	VDDCAP = 4.75 V
Temperature Resolution per Code		0.125		°C	
<b>BUFFERED VOLTAGE OUTPUT DACs</b>					
Resolution		8		Bits	
Code 0x80 Output Voltage					Six DACs are individually selectable for centering on one of four output voltage ranges
Range 1	0.592	0.6	0.603	V	
Range 2	0.796	0.8	0.803	V	
Range 3	0.996	1	1.003	V	
Range 4	1.246	1.25	1.253	V	
Output Voltage Range		601.25		mV	Same range, independent of center point
LSB Step Size		2.36		mV	
INL			±0.75	LSB	Endpoint corrected
DNL			±0.4	LSB	
Gain Error			1	%	
Load Regulation		-4		mV	Sourcing current, I <sub>REFOUTMAX</sub> = -200 µA
		2		mV	Sinking current, I <sub>REFOUTMAX</sub> = 100 µA
Maximum Load Capacitance			50	pF	
Settling Time to 50 pF Load			2	µs	
Load Regulation		2.5		mV	Per mA
PSRR		60		dB	DC
		40		dB	100 mV step in 20 ns with 50 pF load
<b>REFERENCE OUTPUT</b>					
Reference Output Voltage	2.043	2.048	2.053	V	No load
Load Regulation		-0.25		mV	Sourcing current, I <sub>DACHMAX</sub> = -100 µA
		0.25		mV	Sinking current, I <sub>DACHMAX</sub> = 100 µA
Minimum Load Capacitance	1			µF	Capacitor required for decoupling, stability
Load Regulation		2		mV	Per 100 µA
PSRR		60		dB	DC
<b>PROGRAMMABLE DRIVER OUTPUTS</b>					
High Voltage (Charge-Pump) Mode (PDO1 to PDO6)					
Output Impedance		500		kΩ	
V <sub>OH</sub>	11	12.5	14	V	I <sub>OH</sub> = 0
	10.5	12	13.5	V	I <sub>OH</sub> = 1 µA
I <sub>OUTAVG</sub>		20		µA	2 V < V <sub>OH</sub> < 7 V

# ADM1063

Parameter	Min	Typ	Max	Unit	Test Conditions/Comments
Standard (Digital Output) Mode (PDO1 to PDO10) $V_{OH}$	2.4		4.5	V	$V_{PU}$ (pull-up to VDDCAP or VPn) = 2.7 V, $I_{OH} = 0.5$ mA
				V	$V_{PU}$ to VPn = 6.0 V, $I_{OH} = 0$ mA
	$V_{PU} - 0.3$			V	$V_{PU} \leq 2.7$ V, $I_{OH} = 0.5$ mA
$V_{OL}$	0		0.50	V	$I_{OL} = 20$ mA
$I_{OL}^3$			20	mA	Maximum sink current per PDO pin
$I_{SINK}^3$			60	mA	Maximum total sink for all PDO pins
$R_{PULL-UP}$		20		k $\Omega$	Internal pull-up
$I_{SOURCE}$ (VPn) <sup>3</sup>			2	mA	Current load on any VPn pull-ups, that is, total source current available through any number of PDO pull-up switches configured onto any one
Three-State Output Leakage Current			10	$\mu$ A	$V_{PDO} = 14.4$ V
Oscillator Frequency	90	100	110	kHz	All on-chip time delays derived from this clock
DIGITAL INPUTS (VXn, A0, A1)					
Input High Voltage, $V_{IH}$	2.0			V	Maximum $V_{IN} = 5.5$ V
Input Low Voltage, $V_{IL}$			0.8	V	Maximum $V_{IN} = 5.5$ V
Input High Current, $I_{IH}$	-1			$\mu$ A	$V_{IN} = 5.5$ V
Input Low Current, $I_{IL}$			1	$\mu$ A	$V_{IN} = 0$
Input Capacitance		5		pF	
Programmable Pull-Down Current, $I_{PULL-DOWN}$		20		$\mu$ A	VDDCAP = 4.75, $T_A = 25^\circ\text{C}$ if known logic state is required
SERIAL BUS DIGITAL INPUTS (SDA, SCL)					
Input High Voltage, $V_{IH}$	2.0			V	
Input Low Voltage, $V_{IL}$			0.8	V	
Output Low Voltage, $V_{OL}^3$			0.4	V	$I_{OUT} = -3.0$ mA
SERIAL BUS TIMING					
Clock Frequency, $f_{SCLK}$			400	kHz	
Bus Free Time, $t_{BUF}$	4.7			$\mu$ s	
Start Setup Time, $t_{SU,STA}$	4.7			$\mu$ s	
Start Hold Time, $t_{HD,STA}$	4			$\mu$ s	
SCL Low Time, $t_{LOW}$	4.7			$\mu$ s	
SCL High Time, $t_{HIGH}$	4			$\mu$ s	
SCL, SDA Rise Time, $t_r$			1000	$\mu$ s	
SCL, SDA Fall Time, $t_f$			300	$\mu$ s	
Data Setup Time, $t_{SU,DAT}$	250			ns	
Data Hold Time, $t_{HD,DAT}$	5			ns	
Input Low Current, $I_{IL}$			1	$\mu$ A	$V_{IN} = 0$
SEQUENCING ENGINE TIMING					
State Change Time		10		$\mu$ s	

<sup>1</sup> At least one of the VH, VP1 to VP4 pins must be  $\geq 3.0$  V to maintain the device supply on VDDCAP.

<sup>2</sup> All temperature sensor measurements are taken with round-robin loop enabled and at least one other voltage input being measured.

<sup>3</sup> Specification is not production tested, but is supported by characterization data at initial product release.

## PIN CONFIGURATIONS AND FUNCTION DESCRIPTIONS

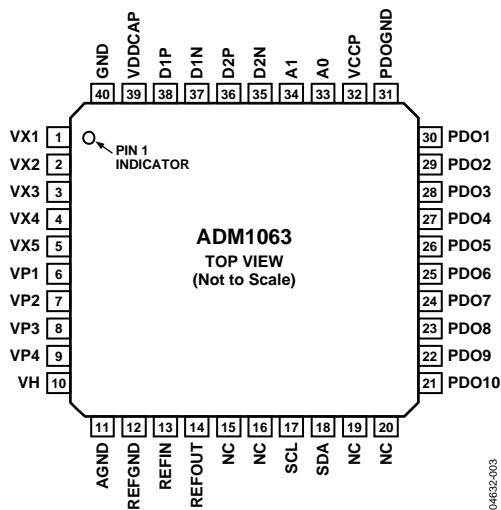
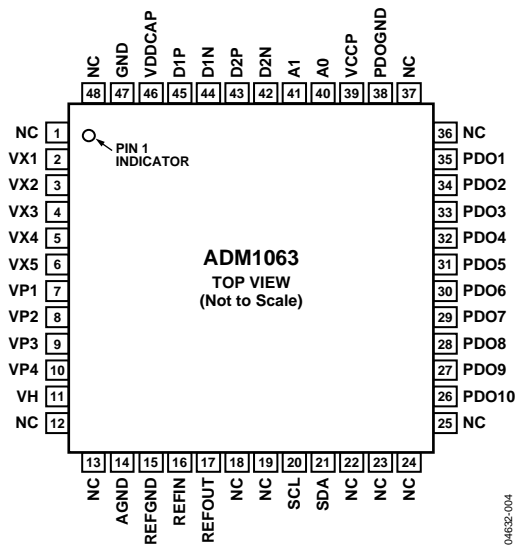

Figure 3. LFCSP Pin Configuration



NC = NO CONNECT

Figure 4. TQFP Pin Configuration

Table 2. Pin Function Descriptions

Pin No.		Mnemonic	Description
LFCSP	TQFP		
15, 16, 19, 20	1, 12, 13, 18, 19, 22 to 25, 36, 37, 48	NC	No Connection.
1 to 5	2 to 6	VX1 to VX5	High Impedance Inputs to Supply Fault Detectors. Fault thresholds can be set from 0.573 V to 1.375 V. Alternatively, these pins can be used as general-purpose digital inputs.
6 to 9	7 to 10	VP1 to VP4	Low Voltage Inputs to Supply Fault Detectors. Three input ranges can be set by altering the input attenuation on a potential divider connected to these pins, the output of which connects to a supply fault detector. These pins allow thresholds from 2.5 V to 6.0 V, 1.25 V to 3.00 V, and 0.573 V to 1.375 V.
10	11	VH	High Voltage Input to Supply Fault Detectors. Two input ranges can be set by altering the input attenuation on a potential divider connected to this pin, the output of which connects to a supply fault detector. This pin allows thresholds from 6.0 V to 14.4 V and 2.5 V to 6.0 V.
11	14	AGND	Ground Return for Input Attenuators.
12	15	REFGND	Ground Return for On-Chip Reference Circuits.
13	16	REFIN	Reference Input for ADC. Nominally, 2.048 V.
14	17	REFOUT	Reference Output, 2.048 V.
17	20	SCL	SMBus Clock Pin. Open-drain output requires external resistive pull-up.
18	21	SDA	SMBus Data I/O Pin. Open-drain output requires external resistive pull-up.
21 to 30	26 to 35	PDO10 to PDO1	Programmable Output Drivers.
31	38	PDOGND	Ground Return for Output Drivers.
32	39	VCCP	Central Charge-Pump Voltage of 5.25 V. A reservoir capacitor must be connected between this pin and GND.
33	40	A0	Logic Input. This pin sets the seventh bit of the SMBus interface address.
34	41	A1	Logic Input. This pin sets the sixth bit of the SMBus interface address.
35	42	D2N	External Temperature Sensor 1 Cathode Connection.
36	43	D2P	External Temperature Sensor 1 Anode Connection.
37	44	D1N	External Temperature Sensor 1 Cathode Connection.
38	45	D1P	External Temperature Sensor 1 Anode Connection.
39	46	VDDCAP	Device Supply Voltage. Linearly regulated from the highest voltage on the VP1 to VP4 and VH pins to a typical voltage of 4.75 V.
40	47	GND	Ground Supply.

## ABSOLUTE MAXIMUM RATINGS

Table 3.

Parameter	Rating
Voltage on VH Pin	16 V
Voltage on VP Pins	7 V
Voltage on VX Pins	-0.3 V to +6.5 V
Voltage on DxN, DxP, and REFIN Pins	-0.3 V to +5 V
Input Current at Any Pin	±5 mA
Package Input Current	±20 mA
Maximum Junction Temperature (T <sub>J</sub> max)	150°C
Storage Temperature Range	-65°C to +150°C
Lead Temperature, Soldering	
Vapor Phase, 60 sec	215°C
ESD Rating, All Pins	2000 V

Stresses above those listed under Absolute Maximum Ratings may cause permanent damage to the device. This is a stress rating only; functional operation of the device at these or any other conditions above those indicated in the operational section of this specification is not implied. Exposure to absolute maximum rating conditions for extended periods may affect device reliability.

### THERMAL CHARACTERISTICS

40-lead LFCSP package:  $\theta_{JA} = 25^{\circ}\text{C}/\text{W}$ .

48-lead TQFP package:  $\theta_{JA} = 14.8^{\circ}\text{C}/\text{W}$ .

### ESD CAUTION

ESD (electrostatic discharge) sensitive device. Electrostatic charges as high as 4000 V readily accumulate on the human body and test equipment and can discharge without detection. Although this product features proprietary ESD protection circuitry, permanent damage may occur on devices subjected to high energy electrostatic discharges. Therefore, proper ESD precautions are recommended to avoid performance degradation or loss of functionality.





# TYPICAL PERFORMANCE CHARACTERISTICS

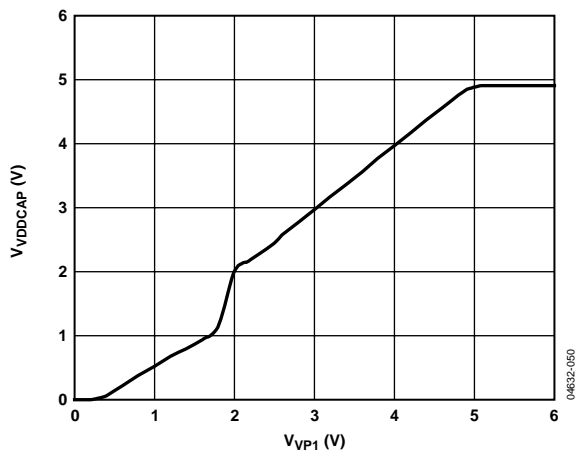

Figure 5.  $V_{VDDCAP}$  vs.  $V_{VP1}$

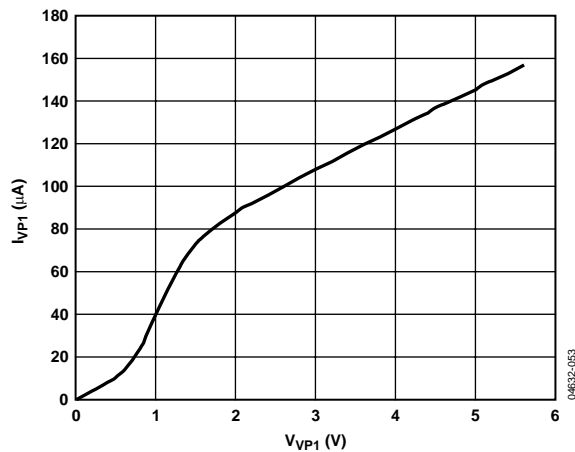

Figure 8.  $I_{VP1}$  vs.  $V_{VP1}$  (VP1 Not as Supply)

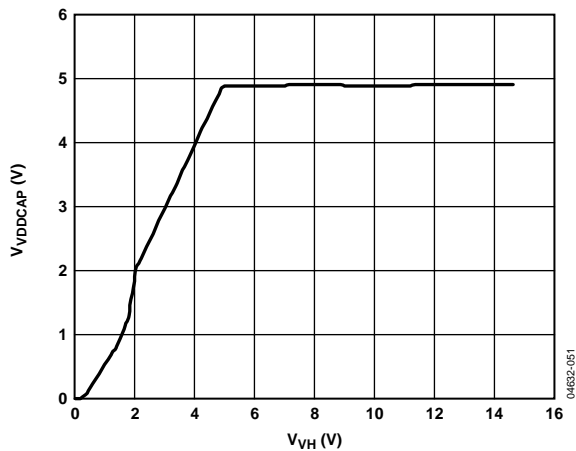

Figure 6.  $V_{VDDCAP}$  vs.  $V_{VH}$

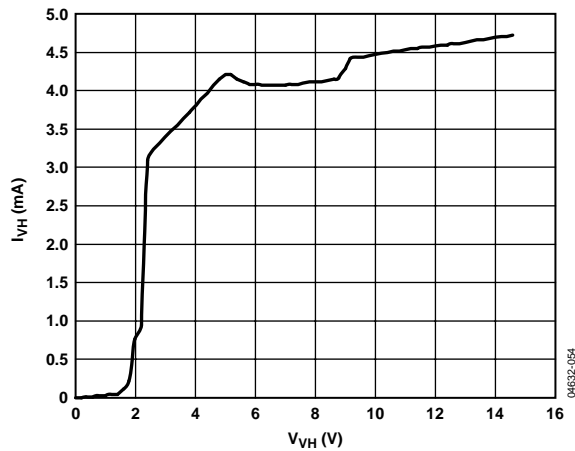

Figure 9.  $I_{VH}$  vs.  $V_{VH}$  (VH as Supply)

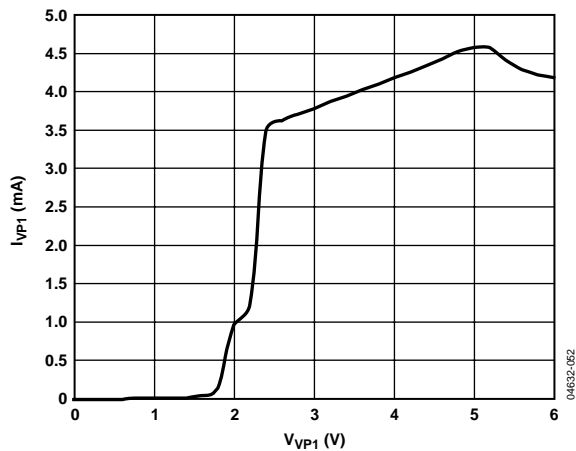

Figure 7.  $I_{VP1}$  vs.  $V_{VP1}$  (VP1 as Supply)

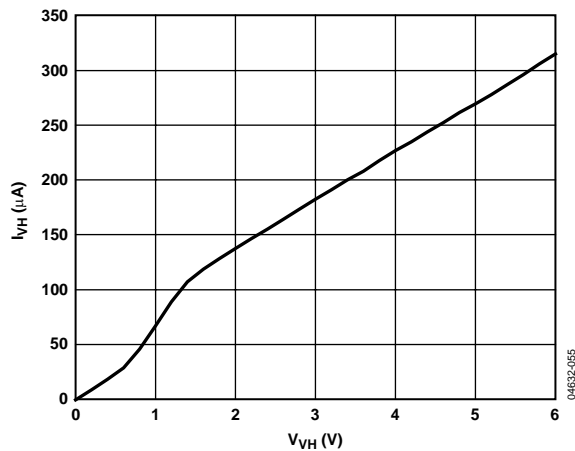

Figure 10.  $I_{VH}$  vs.  $V_{VH}$  (VH Not as Supply)

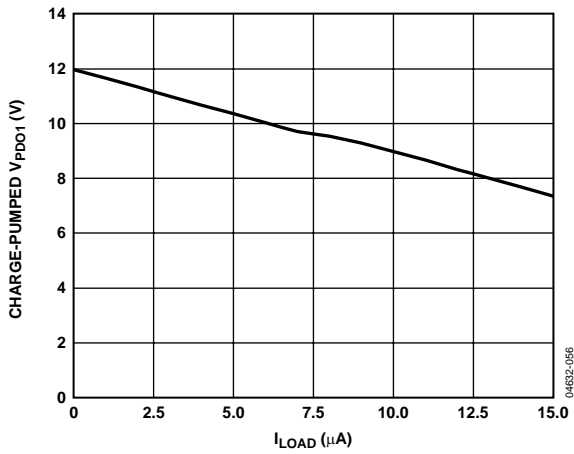

Figure 11. Charge-Pumped  $V_{PDO1}$  (FET Drive Mode) vs.  $I_{LOAD}$

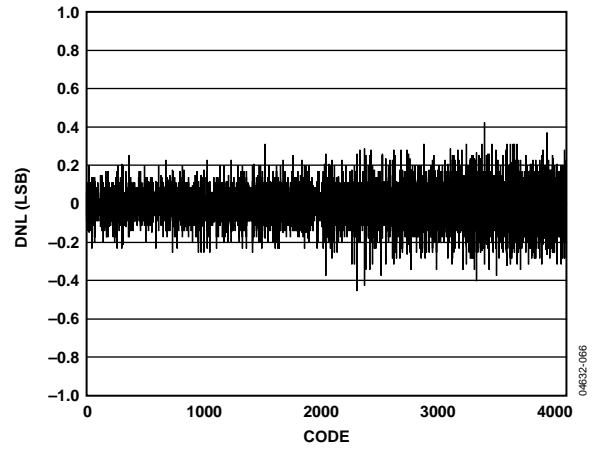

Figure 14. DNL for ADC

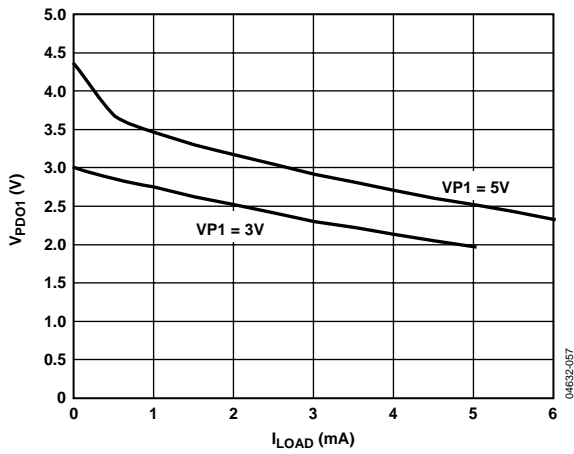

Figure 12.  $V_{PDO1}$  (Strong Pull-Up to VP) vs.  $I_{LOAD}$

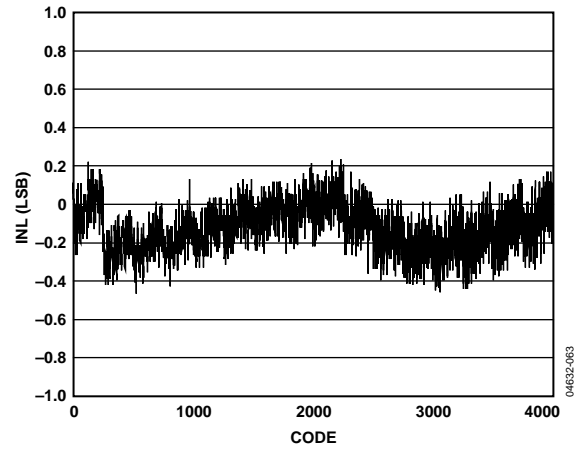

Figure 15. INL for ADC

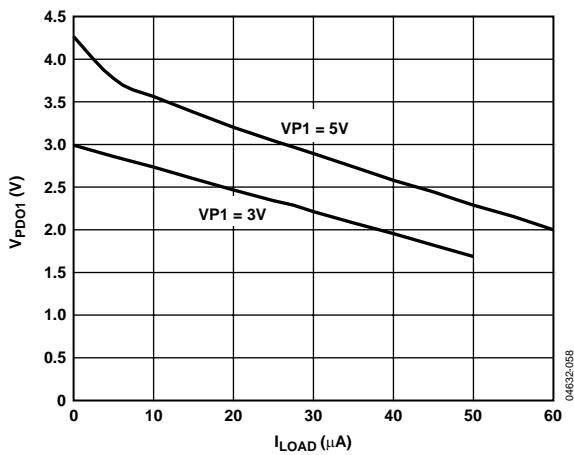

Figure 13.  $V_{PDO1}$  (Weak Pull-Up to VP) vs.  $I_{LOAD}$

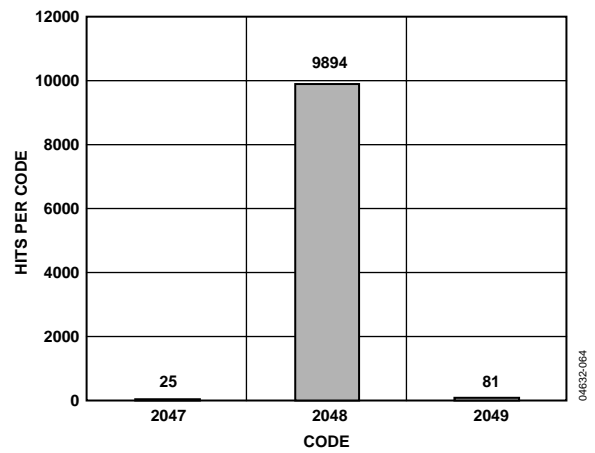

Figure 16. ADC Noise, Midcode Input, 10,000 Reads

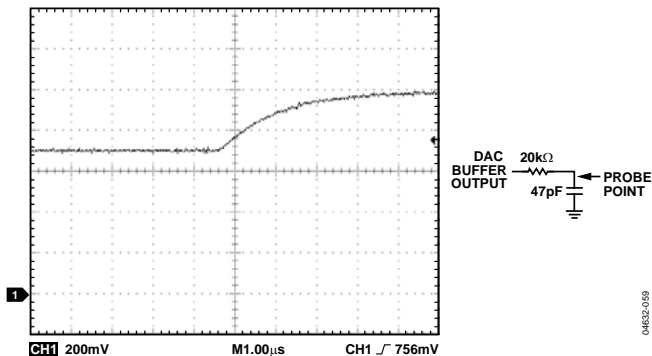

Figure 17. Transient Response of DAC Code Change into Typical Load

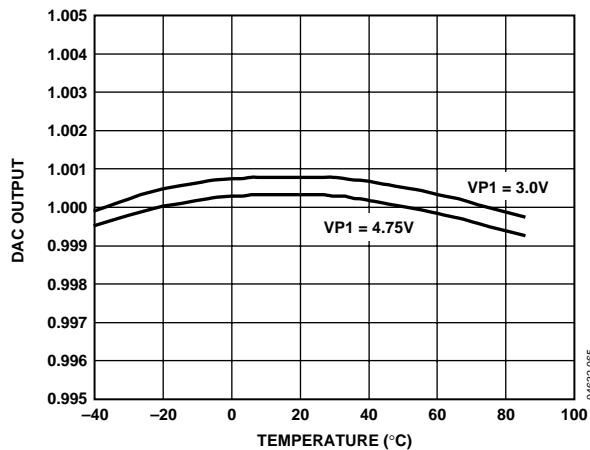

Figure 19. DAC Output vs. Temperature

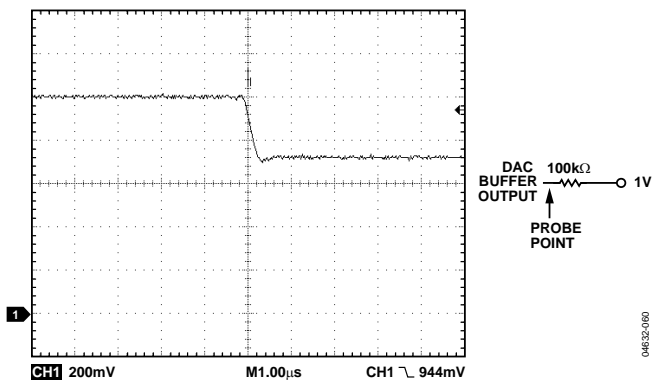

Figure 18. Transient Response of DAC to Turn-On from HI-Z State

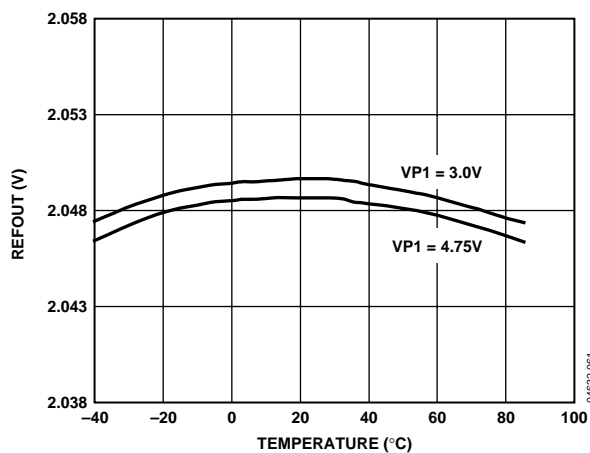

Figure 20. REFOUT vs. Temperature

## POWERING THE ADM1063

The ADM1063 is powered from the highest voltage input on either the positive-only supply inputs (VPn) or the high voltage supply input (VH). This technique offers improved redundancy, because the device is not dependent on any particular voltage rail to keep it operational. The same pins are used for supply fault detection (discussed in the Programming the Supply Fault Detectors section). A V<sub>DD</sub> arbitrator on the device chooses which supply to use. The arbitrator can be considered an OR'ing of five LDOs together. A supply comparator determines which of the inputs is highest and selects it to provide the on-chip supply. There is minimal switching loss with this architecture (~0.2 V), resulting in the ability to power the ADM1063 from a supply as low as 3.0 V. Note that the supply on the VXn pins cannot be used to power the device.

An external capacitor to GND is required to decouple the on-chip supply from noise. This capacitor should be connected to the VDDCAP pin, as shown in Figure 21. The capacitor has another use during brownouts (momentary loss of power). Under these conditions, when the input supply (VPn or VH) dips transiently below V<sub>DD</sub>, the synchronous rectifier switch immediately turns off so that it does not pull V<sub>DD</sub> down. The VDDCAP can then act as a reservoir to keep the device active until the next highest supply takes over the powering of the device. For this reservoir/decoupling function, 10 μF is recommended.

Note that when two or more supplies are within 100 mV of each other, the supply that takes control of V<sub>DD</sub> first keeps control. For example, if VP1 is connected to a 3.3 V supply, then V<sub>DD</sub> powers up to approximately 3.1 V through VP1. If VP2 is then connected to another 3.3 V supply, VP1 still powers the device, unless VP2 goes 100 mV higher than VP1.

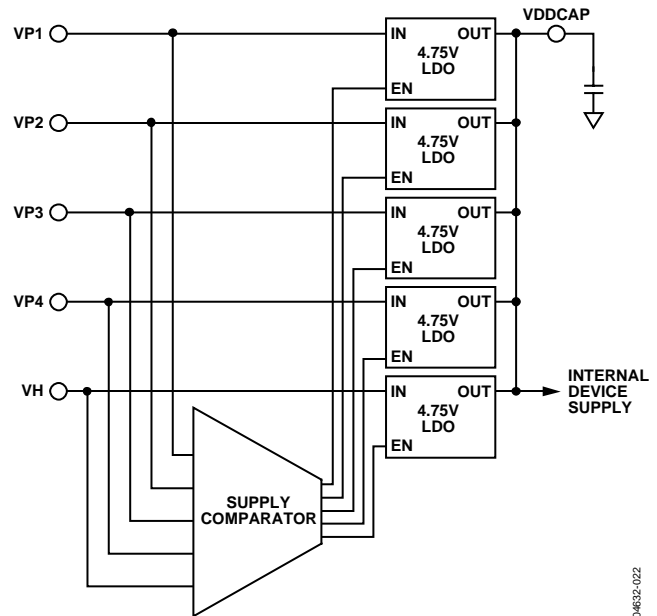

Figure 21. V<sub>DD</sub> Arbitrator Operation

04832-022

# INPUTS

## SUPPLY SUPERVISION

The ADM1063 has 10 programmable inputs. Five of these are dedicated supply fault detectors (SFDs). These dedicated inputs are called VH and VP1 to VP4 by default. The other five inputs are labeled VX1 to VX5 and have dual functionality. They can be used as either SFDs with similar functionality to VH and VP1 to VP4, or CMOS-/TTL-compatible logic inputs to the devices. Therefore, the ADM1063 can have up to 10 analog inputs, a minimum of five analog inputs and five digital inputs, or a combination. If an input is used as an analog input, it cannot be used as a digital input. Therefore, a configuration requiring 10 analog inputs has no digital inputs available. Table 5 shows the details of each of the inputs.

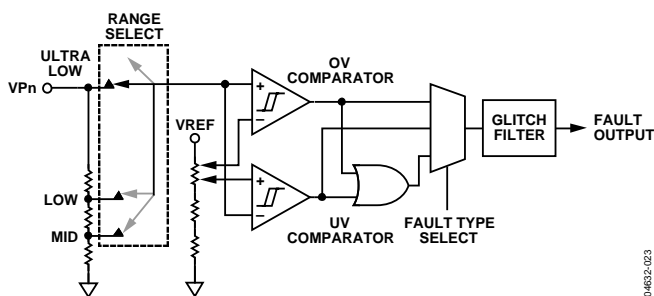

Figure 22. Supply Fault Detector Block

## PROGRAMMING THE SUPPLY FAULT DETECTORS

The ADM1063 can have up to 10 SFDs on its 10 input channels. These highly programmable reset generators enable the supervision of up to 10 supply voltages. The supplies can be as low as 0.573 V and as high as 14.4 V. The inputs can be configured to detect an undervoltage fault (the input voltage drops below a preprogrammed value), an overvoltage fault (the input voltage rises above a preprogrammed value), or an out-of-window fault (an undervoltage or overvoltage). The thresholds can be programmed to an 8-bit resolution in registers provided in the ADM1063. This translates to a voltage resolution that is dependent on the range selected.

The resolution is given by

$$\text{Step Size} = \text{Threshold Range}/255$$

Therefore, if the high range is selected on VH, the step size can be calculated as follows:

$$(14.4 \text{ V} - 4.8 \text{ V})/255 = 37.6 \text{ mV}$$

Table 4 lists the upper and lower limits of each available range, the bottom of each range ( $V_B$ ), and the range itself ( $V_R$ ).

Table 4. Voltage Range Limits

Voltage Range (V)	$V_B$ (V)	$V_R$ (V)
0.573 to 1.375	0.573	0.802
1.25 to 3.00	1.25	1.75
2.5 to 6.0	2.5	3.5
4.8 to 14.4	4.8	9.6

The threshold value required is given by

$$V_T = (V_R \times N)/255 + V_B$$

where:

$V_T$  is the desired threshold voltage (UV or OV).

$V_R$  is the voltage range.

$N$  is the decimal value of the 8-bit code.

$V_B$  is the bottom of the range.

Reversing the equation, the code for a desired threshold is given by

$$N = 255 \times (V_T - V_B)/V_R$$

For example, if the user wants to set a 5 V OV threshold on VP1, the code to be programmed in the PS1OVTH register (discussed in the AN-698 application note) is given by

$$N = 255 \times (5 - 2.5)/3.5$$

Therefore,  $N = 182$  (1011 0110 or 0xB6).

Table 5. Input Functions, Thresholds, and Ranges

Input	Function	Voltage Range (V)	Maximum Hysteresis	Voltage Resolution (mV)	Glitch Filter ( $\mu$ s)
VH	High V analog input	2.5 to 6.0	425 mV	13.7	0 to 100
		4.8 to 14.4	1.16 V	37.6	0 to 100
VPn	Positive analog input	0.573 to 1.375	97.5 mV	3.14	0 to 100
		1.25 to 3.00	212 mV	6.8	0 to 100
		2.5 to 6.0	425 mV	13.7	0 to 100
		0.573 to 1.375	97.5 mV	3.14	0 to 100
VXn	High Z analog input	0.573 to 1.375	97.5 mV	3.14	0 to 100
	Digital input	0 to 5	N/A	N/A	0 to 100

## INPUT COMPARATOR HYSTERESIS

The UV and OV comparators shown in Figure 22 are always looking at VPn. To avoid chattering (multiple transitions when the input is very close to the set threshold level), these comparators have digitally programmable hysteresis. The hysteresis can be programmed up to the values shown in Table 5.

The hysteresis is added after a supply voltage goes out of tolerance. Therefore, the user can program the amount above the UV threshold that the input must rise to before a UV fault is deasserted. Similarly, the user can program the amount below the OV threshold that an input must fall to before an OV fault is deasserted.

The hysteresis figure is given by

$$V_{HYST} = V_R \times N_{THRESH}/255$$

where:

$V_{HYST}$  is the desired hysteresis voltage.

$N_{THRESH}$  is the decimal value of the 5-bit hysteresis code.

Note that  $N_{THRESH}$  has a maximum value of 31. The maximum hysteresis for the ranges are listed in Table 5.

## INPUT GLITCH FILTERING

The final stage of the SFDs is a glitch filter. This block provides time-domain filtering on the output of the SFD comparators. This allows the user to remove any spurious transitions, such as supply bounce at turn-on. The glitch filter function is additional to the digitally programmable hysteresis of the SFD comparators. The glitch filter timeout is programmable up to 100  $\mu$ s.

For example, when the glitch filter timeout is 100  $\mu$ s, any pulse appearing on the input of the glitch filter block that is less than 100  $\mu$ s in duration is prevented from appearing on the output of the glitch filter block. Any input pulse that is longer than 100  $\mu$ s does appear on the output of the glitch filter block. The output is delayed with respect to the input by 100  $\mu$ s. The filtering process is shown in Figure 23.

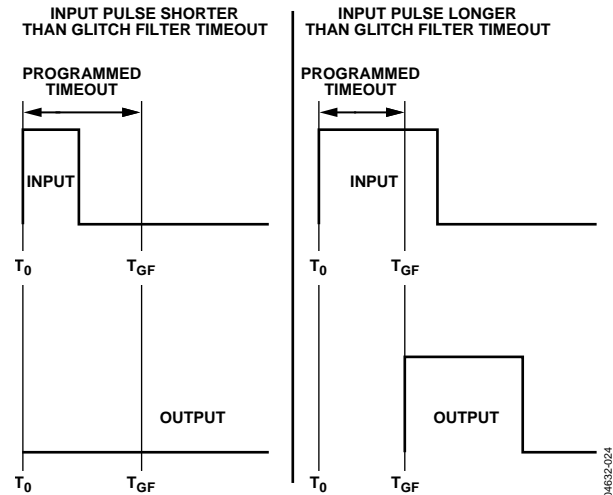

Figure 23. Input Glitch Filter Function

## SUPPLY SUPERVISION WITH VXn INPUTS

The VXn inputs have two functions. They can be used as either supply fault detectors or digital logic inputs. When selected as an analog (SFD) input, the VXn pins function similarly to the VH and VPn pins. The primary difference is that the VXn pins have only one input range: 0.573 V to 1.375 V. Therefore, these inputs can directly supervise only the very low supplies. However, the input impedance of the VXn pins is high, allowing an external resistor divide network to be connected to the pin. Thus, potentially any supply can be divided down into the input range of the VXn pin and supervised. This enables the ADM1063 to monitor other supplies such as +24 V, +48 V, and -5 V.

An additional supply supervision function is available when the VXn pins are selected as digital inputs. In this case, the analog function is available as a second detector on each of the dedicated analog inputs, VP1 to VP4 and VH. The analog function of VX1 is mapped to VP1, VX2 is mapped to VP2, and so on; VX5 is mapped to VH. In this case, these SFDs can be viewed as a secondary or warning SFD.

The secondary SFDs are fixed to the same input range as the primary SFD. They are used to indicate warning levels rather than failure levels. This allows faults and warnings to be generated on a single supply using only one pin. For example, if VP1 is set to output a fault when a 3.3 V supply drops to 3.0 V, VX1 can be set to output a warning at 3.1 V. Warning outputs are available for readback from the status registers. They are also ORed together and fed into the SE, allowing warnings to generate interrupts on the PDOs. Therefore, in the previous example, if the supply drops to 3.1 V, a warning is generated and remedial action can be taken before the supply drops out of tolerance.

## VXn PINS AS DIGITAL INPUTS

As discussed in the Supply Supervision with VXn Inputs, the VXn input pins on the ADM1063 have dual functionality. The second function is as a digital input to the device. Therefore, the ADM1063 can be configured for up to five digital inputs. These inputs are TTL-/CMOS-compatible. Standard logic signals can be applied to the pins: RESET from reset generators, POWER\_GOOD signals, fault flags, manual resets, and so on. These signals are available as inputs to the SE and, therefore, can be used to control the status of the PDOs. The inputs can be configured to detect either a change in level or an edge.

When configured for level detection, the output of the digital block is a buffered version of the input. When configured for edge detection, a pulse of programmable width is output from the digital block once the logic transition is detected. The width is programmable from 0  $\mu$ s to 100  $\mu$ s.

The digital blocks feature the same glitch filter function that is available on the SFDs. This enables the user to ignore spurious transitions on the inputs. For example, the filter can be used to debounce a manual reset switch.

When configured as digital inputs, each of the VXn pins has a weak (10  $\mu$ A) pull-down current source available for placing the input into a known condition, even if left floating. The current source, if selected, weakly pulls the input to GND.

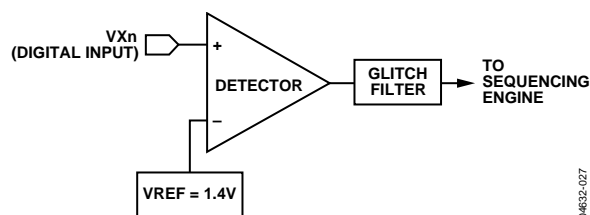

Figure 24. VXn Digital Input Function

04832-027

## OUTPUTS

### SUPPLY SEQUENCING THROUGH CONFIGURABLE OUTPUT DRIVERS

Supply sequencing is achieved with the ADM1063 using the programmable driver outputs (PDOs) on the device as control signals for supplies. The output drivers can be used as logic enables or as FET drivers.

The sequence in which the PDOs are asserted (and, therefore, the supplies are turned on) is controlled by the sequencing engine (SE). The SE determines what action is taken with the PDOs based on the condition of the inputs of the ADM1063. Therefore, the PDOs can be set up to assert when the SFDs are in tolerance, the correct input signals are received on the VXn digital pins, no warnings are received from any of the inputs of the device, and so on. The PDOs can be used for a variety of functions. The primary function is to provide enable signals for LDOs or dc-to-dc converters, which generate supplies locally on a board. The PDOs can also be used to provide a POWER\_GOOD signal when all the SFDs are in tolerance, or a RESET output if one of the SFDs goes out of specification (this can be used as a status signal for a DSP, FPGA, or other microcontroller).

The PDOs can be programmed to pull up to a number of different options. The outputs can be programmed as follows:

- Open-drain (allowing the user to connect an external pull-up resistor)
- Open-drain with weak pull-up to  $V_{DD}$
- Push/pull to  $V_{DD}$
- Open-drain with weak pull-up to  $VP_n$
- Push/pull to  $VP_n$
- Strong pull-down to GND
- Internally charge-pumped high drive (12 V, PDO1 to PDO6 only)

The last option (available only on PDO1 to PDO6) allows the user to directly drive a voltage high enough to fully enhance an

external N-channel FET, which is used to isolate, for example, a card-side voltage from a backplane supply (a PDO can sustain greater than 10.5 V into a 1  $\mu$ A load). The pull-down switches can also be used to drive status LEDs directly.

The data driving each of the PDOs can come from one of three sources. The source can be enabled in the PDOncFG configuration register (see the [AN-698](#) application note for details).

The data sources are as follows:

- Output from the SE.
- Directly from the SMBus. A PDO can be configured so that the SMBus has direct control over it. This enables software control of the PDOs. Therefore, a microcontroller can be used to initiate a software power-up/power-down sequence.
- On-Chip Clock. A 100 kHz clock is generated on the device. This clock can be made available on any of the PDOs. It can be used, for example, to clock an external device such as an LED.

By default, the PDOs are pulled to GND by a weak (20 k $\Omega$ ) on-chip, pull-down resistor. This is the case upon power-up until the configuration is downloaded from EEPROM and the programmed setup is latched. The outputs are actively pulled low once a supply of 1 V or greater is on  $VP_n$  or  $VH$ . The outputs remain high impedance prior to 1 V appearing on  $VP_n$  or  $VH$ . This provides a known condition for the PDOs during power-up. The internal pull-down can be overdriven with an external pull-up of suitable value tied from the PDO pin to the required pull-up voltage. The 20 k $\Omega$  resistor must be accounted for in calculating a suitable value. For example, if PDO<sub>n</sub> must be pulled up to 3.3 V and 5 V is available as an external supply, the pull-up resistor value is given by

$$3.3 \text{ V} = 5 \text{ V} \times 20 \text{ k}\Omega / (R_{UP} + 20 \text{ k}\Omega)$$

Therefore,

$$R_{UP} = (100 \text{ k}\Omega - 66 \text{ k}\Omega) / 3.3 = 10 \text{ k}\Omega$$

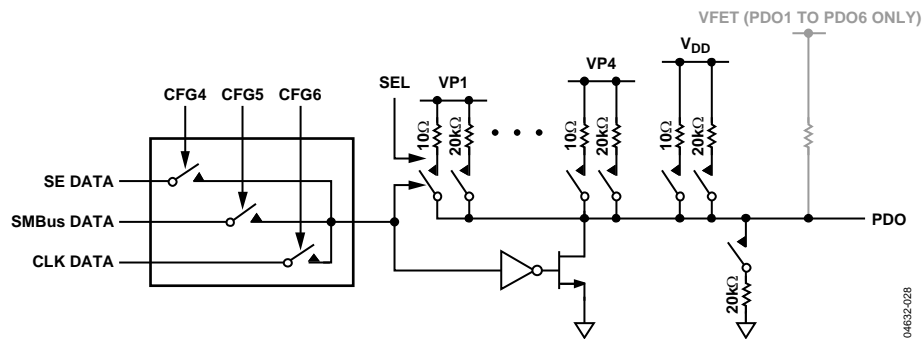

Figure 25. Programmable Driver Output



# SEQUENCING ENGINE

## OVERVIEW

The ADM1063 sequencing engine (SE) provides the user with powerful and flexible control of sequencing. The SE implements a state machine control of the PDO outputs, with state changes conditional on input events. SE programs can enable complex control of boards such as power-up and power-down sequence control, fault event handling, interrupt generation on warnings, and so on. A watchdog function that verifies the continued operation of a processor clock can be integrated into the SE program. The SE can also be controlled via the SMBus, giving software or firmware control of the board sequencing.

The SE state machine comprises 63 state cells. Each state has the following attributes:

- Monitors signals indicating the status of the 10 input pins, VP1 to VP4, VH, and VX1 to VX5.
- Can be entered from any other state.
- Three exit routes move the state machine onto a next state: sequence detection, fault monitoring, and timeout.
- Delay timers for the sequence and timeout blocks can be programmed independently and changed with each state change. The range of timeouts is from 0 ms to 400 ms.
- Output condition of the 10 PDO pins is defined and fixed within a state.
- Transition from one state to the next is made in less than 20  $\mu$ s, which is the time needed to download a state definition from EEPROM to the SE.

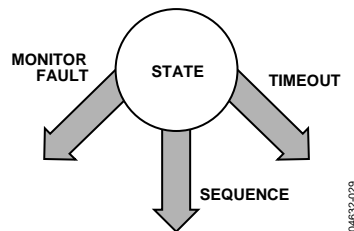

Figure 26. State Cell

The ADM1063 offers up to 63 state definitions. The signals monitored to indicate the status of the input pins are the outputs of the SFDs.

## WARNINGS

The SE also monitors warnings. These warnings can be generated when the ADC readings violate their limit register value or when the secondary voltage monitors detect a warning on VP1 to VP4 and VH. The warnings are OR'ed together and available as a single warning input to each of the three blocks that enable exiting a state.

## SMBus JUMP (UNCONDITIONAL JUMP)

The SE can be forced to advance to the next state unconditionally. This enables the user to force the SE to advance. Examples of where this might be used include moving to a margining state or debugging a sequence. The SMBus jump or go-to command can be seen as another input to sequence and timeout blocks, which provide an exit from each state.

Table 6. Sample Sequence State Entries

State	Sequence	Timeout	Monitor
IDLE1	If VX1 is low , go to state IDLE2.		
IDLE2	If VP1 is okay, go to state EN3V3.		
EN3V3	If VP2 is okay, go to state EN2V5.	If VP2 is not okay after 10 ms, go to state DIS3V3.	If VP1 is not okay, go to state IDLE1.
DIS3V3	If VX1 is high, go to state IDLE1.		
EN2V5	If VP3 is okay, go to state PWRGD.	If VP3 is not okay after 20 ms, go to state DIS2V5.	If VP1 or VP2 is not okay, go to state FSEL2.
DIS2V5	If VX1 is high, go to state IDLE1.		
FSEL1	If VP3 is not okay, go to state DIS2V5.		If VP1 or VP2 is not okay, go to state FSEL2.
FSEL2	If VP2 is not okay, go to state DIS3V3.		If VP1 is not okay, go to state IDLE1.
PWRGD	If VX1 is high, go to state DIS2V5.		If VP1, VP2, or VP3 is not okay, go to state FSEL1.

## SEQUENCING ENGINE APPLICATION EXAMPLE

The application in this section demonstrates the operation of the SE. Figure 27 shows how the simple building block of a single SE state can be used to build a power-up sequence for a 3-supply system.

Table 7 lists the PDO outputs for each state in the same SE implementation. In this system, the triggers required to start a power-up sequence are the presence of a good 5 V supply on VP1 and the VX1 pin held low. The sequence intends to turn on the 3.3 V supply next, then the 2.5 V supply (assuming successful turn-on of the 3.3 V supply). Once all three supplies are good, the POWER\_GOOD state is entered, where the SE remains until a fault occurs on one of the three supplies, or until it is instructed to go through a power-down sequence by VX1 going high.

Faults are dealt with throughout the power-up sequence on a case-by-case basis. The following sections, which describe the individual blocks, use this sample application to demonstrate the state machine's actions.

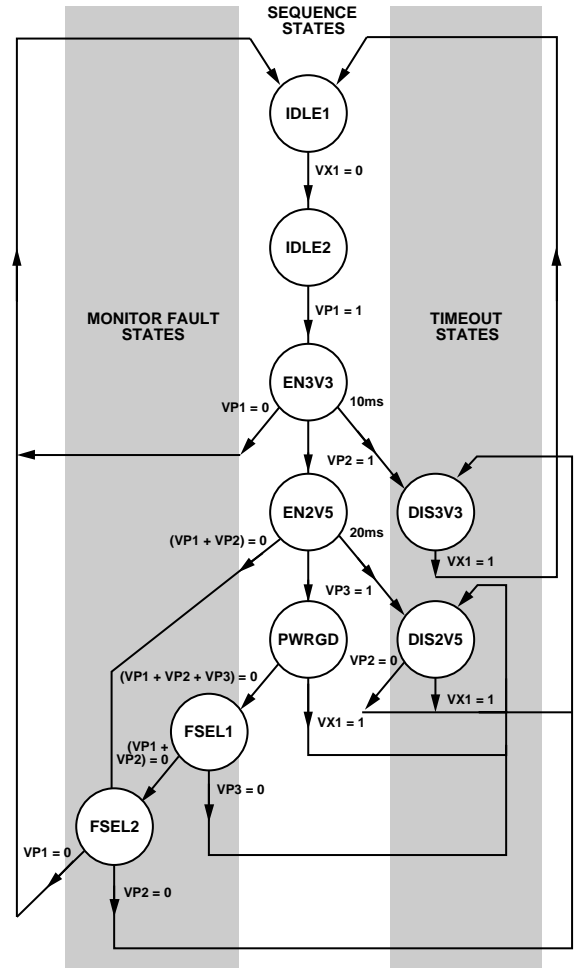

Figure 27. Sample Application Flow Diagram

Table 7. PDO Outputs for Each State

PDO Outputs	IDLE1	IDLE2	EN3V3	EN2V5	DIS3V3	DIS2V5	PWRGD	FSEL1	FSEL2
PDO1 = 3V3ON	0	0	1	1	0	1	1	1	1
PDO2 = 2V5ON	0	0	0	1	1	0	1	1	1
PDO3 = FAULT	0	0	0	0	1	1	0	1	1

## SEQUENCE DETECTOR

The sequence detector block is used to detect when a step in a sequence has been completed. It looks for one of the inputs to the SE to change state and is most often used as the gate for successful progress through a power-up or power-down sequence. A timer block is included in this detector, which can insert delays into a power-up or power-down sequence if required. Timer delays can be set from 10  $\mu$ s to 400 ms. Figure 28 is a block diagram of the sequence detector.

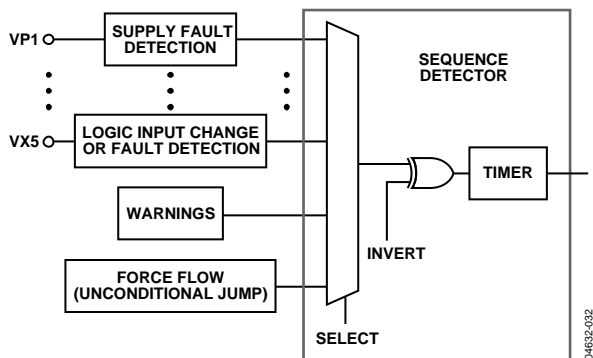

Figure 28. Sequence Detector Block Diagram

The sequence detector can also help to identify monitoring faults. In the sample application shown in Figure 27, the FSEL1 and FSEL2 states identify which of the VP1, VP2, or VP3 pins has faulted, and then they take the appropriate action.

## MONITORING FAULT DETECTOR

The monitoring fault detector block is used to detect a failure on an input. The logical function implementing this is a wide OR gate, which can detect when an input deviates from its expected condition. The clearest demonstration of the use of this block is in the POWER\_GOOD state, where the monitor block indicates that a failure on one or more of the VP1, VP2, or VP3 inputs has occurred.

No programmable delay is available in this block, because the triggering of a fault condition is likely to be caused when a supply falls out of tolerance. In this situation, the user should react as quickly as possible. Some latency occurs when moving out of this state, because it takes a finite amount of time ( $\sim 20 \mu$ s) for the state configuration to download from EEPROM into the SE. Figure 29 is a block diagram of the monitoring fault detector.

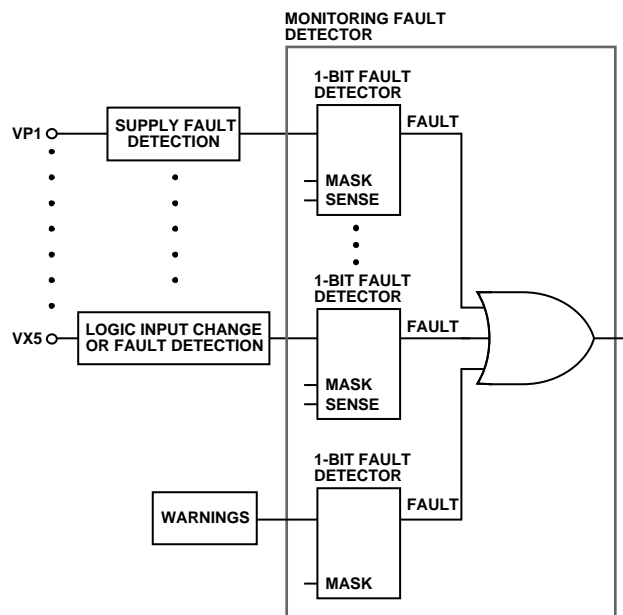

Figure 29. Monitoring Fault Detector Block Diagram

## TIMEOUT DETECTOR

The timeout detector allows the user to trap a failure and, thus ensuring proper progress through a power-up or power-down sequence.

In the sample application shown in Figure 27, the timeout next-state transition is from the EN3V3 and EN2V5 states. For the EN3V3 state, the signal 3V3ON is asserted on the PDO1 output pin upon entry to this state to turn on a 3.3 V supply. This supply rail is connected to the VP2 pin, and the sequence detector looks for the VP2 pin to go above its UV threshold, which is set in the supply fault detector (SFD) attached to that pin.

The power-up sequence progresses when this change is detected. If, however, the supply fails (perhaps due to a short circuit overloading this supply), the timeout block traps the problem. In this example, if the 3.3 V supply fails within 10 ms, the SE moves to the DIS3V3 state and turns off this supply by bringing PDO1 low. It also indicates that a fault has occurred by taking PDO3 high. Timeout delays of 100  $\mu$ s to 400 ms can be programmed.

## FAULT REPORTING

The ADM1063 has a fault latch for recording faults. Two registers are set aside for this purpose. A single bit is assigned to each input of the device, and a fault on that input sets the relevant bit. The contents of the fault register can be read out over the SMBus to determine which input(s) faulted. The fault register can be enabled/disabled in each state. This ensures that only real faults are captured and not, for example, undervoltage trips when the SE is executing a power-down sequence.

## VOLTAGE READBACK

The ADM1063 has an on-board, 12-bit, accurate ADC for voltage readback over the SMBus. The ADC has a 12-channel analog mux on the front end. The 12 channels consist of the 10 SFD inputs (VH, VP1 to VP4, and VX1 to VX5) plus two channels for temperature readback (discussed in the Remote Temperature Measurement section). Any or all of these inputs can be selected to be read, in turn, by the ADC. The circuit controlling this operation is called the round-robin circuit. The round-robin circuit can be selected to run through its loop of conversions once or continuously. Averaging is also provided for each channel. In this case, the round-robin circuit runs through its loop of conversions 16 times before returning a result for each channel. At the end of this cycle, the results are written to the output registers.

The ADC samples single-sided inputs with respect to the AGND pin. A 0 V input gives out Code 0, and an input equal to the voltage on REFIN gives out full code (4095 decimal).

The inputs to the ADC come directly from the VXn pins and from the back of the input attenuators on the VPn and VH pins, as shown in Figure 30 and Figure 31.

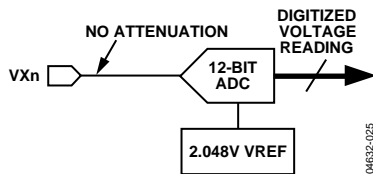

Figure 30. ADC Reading on VXn Pins

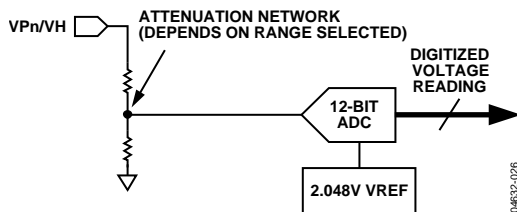

Figure 31. ADC Reading on VPn/VH Pins

The voltage at the input pin can be derived from the following equation:

$$V = \frac{\text{ADC Code}}{4095} \times \text{Attenuation Factor} \times 2.048 \text{ V}$$

The ADC input voltage ranges for the SFD input ranges are listed in Table 8.

Table 8. ADC Input Voltage Ranges

SFD Input Range (V)	Attenuation Factor	ADC Input Voltage Range (V)
0.573 to 1.375	1	0 to 2.048
1.25 to 3	2.181	0 to 4.46
2.5 to 6	4.363	0 to 6.0 <sup>1</sup>
4.8 to 14.4	10.472	0 to 14.4 <sup>1</sup>

<sup>1</sup> The upper limit is the absolute maximum allowed voltage on these pins.

The normal way to supply the reference to the ADC on the REFIN pin is to simply connect the REFOUT pin to the REFIN pin. REFOUT provides a 2.048 V reference. As such, the supervising range covers less than half of the normal ADC range. It is possible, however, to provide the ADC with a more accurate external reference for improved readback accuracy.

Supplies can also be connected to the input pins purely for ADC readback, even though they might go above the expected supervisory range limits (as long as they are not above 6 V, because this violates the absolute maximum ratings on these pins). For instance, a 1.5 V supply connected to the VX1 pin can be correctly read out as an ADC code of approximately 3/4 full scale, but it always sits above any supervisory limits that can be set on that pin. The maximum setting for the REFIN pin is 2.048 V.

## SUPPLY SUPERVISION WITH THE ADC

In addition to the readback capability, a further level of supervision is provided by the on-chip, 12-bit ADC. The ADM1063 has limit registers on which the user can program a maximum or minimum allowable threshold. Exceeding the threshold generates a warning that can either be read back from the status registers or input into the SE to determine what sequencing action the ADM1063 should take. Only one register is provided for each input channel; therefore, either a UV or OV threshold (but not both) can be set for a given channel. The round-robin circuit can be enabled via an SMBus write, or it can be programmed to turn on in any state in the SE program. For example, it can be set to start once a power-up sequence is complete and all supplies are known to be within expected tolerance limits.

Note that a latency is built into this supervision, dictated by the conversion time of the ADC. With all 12 channels selected, the total time for the round-robin operation (averaging off) is approximately 6 ms (500 μs per channel selected). Supervision using the ADC, therefore, does not provide the same real time response as the SFDs.

## SUPPLY MARGINING

### OVERVIEW

It is often necessary for the system designer to adjust supplies, either to optimize their level or force them away from nominal values to characterize the system performance under these conditions. This is a function typically performed during an in-circuit test (ICT), such as when the manufacturer wants to guarantee that a product under test functions correctly at nominal supplies  $\pm 10\%$ .

### OPEN-LOOP MARGINING

The simplest method of margining a supply is to implement an open-loop technique. A popular method for this is to switch extra resistors into the feedback node of a power module, such as a dc-to-dc converter or low dropout regulator (LDO). The extra resistor alters the voltage at the feedback or trim node and forces the output voltage to margin up or down by a certain amount.

The ADM1063 can perform open-loop margining for up to six supplies. The six on-board voltage DACs (DAC1 to DAC6) can drive into the feedback pins of the power modules to be margined. The simplest circuit to implement this function is an attenuation resistor, which connects the DAC<sub>n</sub> pin to the feedback node of a dc-to-dc converter. When the DAC<sub>n</sub> output voltage is set equal to the feedback voltage, no current flows in the attenuation resistor, and the dc-to-dc output voltage does not change. Taking DAC<sub>n</sub> above the feedback voltage forces current into the feedback node, and the output of the dc-to-dc converter is forced to fall to compensate for this. The dc-to-dc output can be forced high by setting the DAC<sub>n</sub> output voltage lower than the feedback node voltage. The series resistor can be split in two, and the node between them decoupled with a capacitor to ground. This can help to decouple any noise picked up from the board. Decoupling to a ground local to the dc-to-dc converter is recommended.

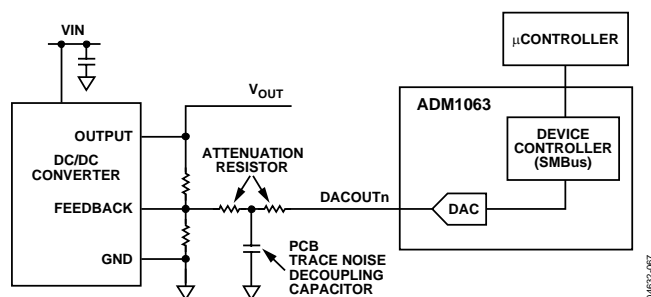

Figure 32. Open-Loop Margining System Using the ADM1063

The ADM1063 can be commanded to margin a supply up or down over the SMBus by updating the values on the relevant DAC output.

### CLOSED-LOOP SUPPLY MARGINING

A much more accurate and comprehensive method of margining is to implement a closed-loop system. With this technique, the voltage of a rail is read back so that it can be accurately margined to the target voltage. The ADM1063 incorporates all the circuits required to do this, with the 12-bit successive approximation ADC used to read back the level of the supervised voltages, and the six voltage output DACs, implemented as described in the Open-Loop Margining section, used to adjust supply levels. These circuits can be used along with other intelligence such as a microcontroller to implement a closed-loop margining system that allows any dc-to-dc or LDO supply to be set to any voltage, accurate to within  $\pm 0.5\%$  of the target.

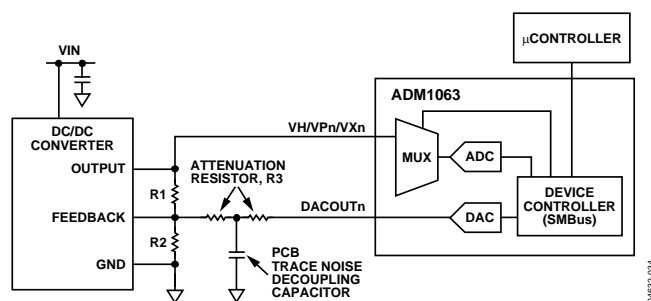

Figure 33. Closed-Loop Margining System Using the ADM1063

To implement closed-loop margining:

1. Disable the six DAC<sub>n</sub> outputs.
2. Set the DAC output voltage equal to the voltage on the feedback node.
3. Enable the DAC.
4. Read the voltage at the dc-to-dc output, which is connected to one of the VP1 to VP4, VH, or VX1 to VX5 pins.
5. If necessary, modify the DAC<sub>n</sub> output code up or down to adjust the dc-to-dc output voltage; otherwise, stop because the target voltage has been reached.
6. Set the DAC output voltage to a value that alters the supply output by the required amount (for example,  $\pm 5\%$ ).
7. Repeat from Step 4.

Step 1 to Step 3 ensure that when the DAC<sub>n</sub> output buffer is turned on, it has little effect on the dc-to-dc output. The DAC output buffer is designed to power up without glitching by first powering up the buffer to follow the pin voltage. It does not drive out onto the pin at this time. Once the output buffer is properly enabled, the buffer input is switched over to the DAC and the output stage of the buffer is turned on. Output glitching is negligible.

## WRITING TO THE DACs

Four DAC ranges are offered. They can be placed with midcode (Code 0x7F) at 0.6 V, 0.8 V, 1.0 V, and 1.25 V. These voltages are placed to correspond to the most common feedback voltages. Centering the DAC outputs in this way provides the best use of the DAC resolution. For most supplies, it is possible to place the DAC midcode at the point where the dc-to-dc output is not modified, thereby giving half of the DAC range to margin up and the other half to margin down.

The DAC output voltage is set by the code written to the DACn register. The voltage is linear with the unsigned binary number in this register. Code 0x7F is placed at the midcode voltage, as described previously. The output voltage is given by the following equation:

$$DAC\ Output = (DACn - 0x7F)/255 \times 0.6015 + V_{OFF}$$

where  $V_{OFF}$  is one of the four offset voltages.

There are 256 DAC settings available. The midcode value is located at DAC Code 0x7F, as close as possible to the middle of the 256 code range. The full output swing of the DACs is +302 mV (+128 codes) and -300 mV (-127 codes) around the selected midcode voltage. The voltage range for each midcode voltage is shown in Table 9.

Table 9. Ranges for Midcode Voltages

Midcode Voltage (V)	Minimum Voltage Output (V)	Maximum Voltage Output (V)
0.6	0.300	0.902
0.8	0.500	1.102
1.0	0.700	1.302
1.25	0.950	1.552

## CHOOSING THE SIZE OF THE ATTENUATION RESISTOR

The degree to which the DAC voltage swing affects the output voltage of the dc-to-dc converter that is being margined is determined by the size of the attenuation resistor, R3 (see Figure 33).

Because the voltage at the feedback pin remains constant, the current flowing from the feedback node to GND via R2 is constant. Also, the feedback node itself is high impedance. This

means that the current flowing through R1 is the same as the current flowing through R3. Therefore, a direct relationship exists between the extra voltage drop across R1 during margining and the voltage drop across R3.

This relationship is given by the following equation:

$$\partial V_{OUT} = \frac{R1}{R3} (V_{FB} - V_{DACOUT})$$

where:

$\partial V_{OUT}$  is the change in  $V_{OUT}$ .

$V_{FB}$  is the voltage at the feedback node of the dc-to-dc converter.

$V_{DACOUT}$  is the voltage output of the margining DAC.

This equation demonstrates that if the user wants the output voltage to change by  $\pm 300$  mV, then  $R1 = R3$ . If the user wants the output voltage to change by  $\pm 600$  mV, then  $R1 = 2 \times R3$ , and so on.

It is best to use the full DAC output range to margin a supply. Choosing the attenuation resistor in this way provides the most resolution from the DAC. In other words, with one DAC code change, the smallest effect on the dc-to-dc output voltage is induced. If the resistor is sized up to use a code such as 27 (dec) to 227 (dec) to move the dc-to-dc output by  $\pm 5\%$ , then it takes 100 codes to move 5% (each code moves the output by 0.05%). This is beyond the readback accuracy of the ADC, but should not prevent the user from building a circuit to use the most resolution.

## DAC LIMITING AND OTHER SAFETY FEATURES

Limit registers (called DPLIMn and DNLIMn) on the device offer the user some protection from firmware bugs, which can cause catastrophic board problems by forcing supplies beyond their allowable output ranges. Essentially, the DAC code written into the DACn register is clipped such that the code used to set the DAC voltage is actually given by

$$\begin{aligned} \text{DAC Code} &= \text{DACn}, \text{DACn} \geq \text{DNLIMn} \text{ and } \text{DACn} \leq \text{DPLIMn} \\ &= \text{DNLIMn}, \text{DACn} < \text{DNLIMn} \\ &= \text{DPLIMn}, \text{DACn} > \text{DPLIMn} \end{aligned}$$

In addition, the DAC output buffer is three-stated if  $\text{DNLIMn} > \text{DPLIMn}$ . By programming the limit registers in this way, the user can make it very difficult for the DAC output buffers to be turned on during normal system operation (these are among the registers downloaded from EEPROM at startup).

## TEMPERATURE MEASUREMENT SYSTEM

The ADM1063 contains an on-chip, band gap temperature sensor, whose output is digitized by the on-chip, 12-bit ADC. Theoretically, the temperature sensor and ADC can measure temperatures from  $-128^{\circ}\text{C}$  to  $+127^{\circ}\text{C}$  with a resolution of  $0.125^{\circ}\text{C}$ . Because this exceeds the operating temperature range of the device, local temperature measurements outside this range are not possible. Temperature measurements from  $-128^{\circ}\text{C}$  to  $+127^{\circ}\text{C}$  are possible using a remote sensor. The output code is in offset binary format, with  $-128^{\circ}\text{C}$  given by Code 0x400,  $0^{\circ}\text{C}$  given by Code 0x800, and  $+127^{\circ}\text{C}$  given by Code 0xC00.

As with the other analog inputs to the ADC, a limit register is provided for each of the temperature input channels. Therefore, a temperature limit can be set such that if it is exceeded, a warning is generated and available as an input to the sequencing engine. This enables users to control their sequence or monitor functions based on an overtemperature or undertemperature event.

### REMOTE TEMPERATURE MEASUREMENT

The ADM1063 can measure the temperature of two remote diode sensors or diode-connected transistors connected to the DxN and DxP pins.

The forward voltage of a diode or diode-connected transistor operated at a constant current exhibits a negative temperature coefficient of about  $-2\text{ mV}/^{\circ}\text{C}$ . Unfortunately, the absolute value of  $V_{be}$  varies from device to device, and individual calibration is required to null this, making the technique unsuitable for mass production. The technique used in the ADM1063 is to measure the change in  $V_{be}$  when the device is operated at two different currents.

This is given by

$$\Delta V_{be} = kT/q \times \ln(N)$$

where:

$k$  is Boltzmann's constant.

$q$  is charge on the carrier.

$T$  is absolute temperature in Kelvin.

$N$  is ratio of the two currents.

Figure 34 shows the input signal conditioning used to measure the output of a remote temperature sensor. This figure shows the external sensor as a substrate transistor provided for temperature monitoring on some microprocessors, but it could equally be a discrete transistor such as a 2N3904 or 2N3906.

If a discrete transistor is used, the collector is not grounded and should be linked to the base. If a PNP transistor is used, the base is connected to the DxN input and the emitter is connected to the DxP input. If an NPN transistor is used, the emitter is connected to the DxN input and the base is connected to the DxP input. Figure 35 and Figure 36 show how to connect the ADM1063 to an NPN or PNP transistor for temperature measurement. To prevent ground noise from interfering with the measurement, the more negative terminal of the sensor is not referenced to ground, but is biased above ground by an internal diode at the DxN input.

To measure  $\Delta V_{be}$ , the sensor is switched between operating currents of  $I$  and  $N \times I$ . The resulting waveform is passed through a 65 kHz low-pass filter to remove noise and through a chopper-stabilized amplifier that amplifies and rectifies the waveform to produce a dc voltage proportional to  $\Delta V_{be}$ . This voltage is measured by the ADC to produce a temperature output in 12-bit offset binary. To further reduce the effects of noise, digital filtering is performed by averaging the results of 16 measurement cycles. A remote temperature measurement takes nominally 600 ms. The results of remote temperature measurements are stored in 12-bit, offset binary format, as shown in Table 10. This provides temperature readings with a resolution of  $0.125^{\circ}\text{C}$ .

**Table 10. Temperature Data Format**

Temperature	Digital Output (Hex)	Digital Output (Bin)
$-128^{\circ}\text{C}$	400	010000000000
$-125^{\circ}\text{C}$	418	010000011000
$-100^{\circ}\text{C}$	4E0	010011100000
$-75^{\circ}\text{C}$	5A8	010110101000
$-50^{\circ}\text{C}$	600	011000000000
$-25^{\circ}\text{C}$	670	011001110000
$-10^{\circ}\text{C}$	7B0	011110110000
$0^{\circ}\text{C}$	800	100000000000
$+10.25^{\circ}\text{C}$	852	100001010010
$+25.5^{\circ}\text{C}$	8CC	100011001100
$+50.75^{\circ}\text{C}$	996	100110010110
$+75^{\circ}\text{C}$	A58	101001011000
$+100^{\circ}\text{C}$	B48	101101001000
$+125^{\circ}\text{C}$	BE8	101111101000
$+128^{\circ}\text{C}$	C00	110000000000

# ADM1063

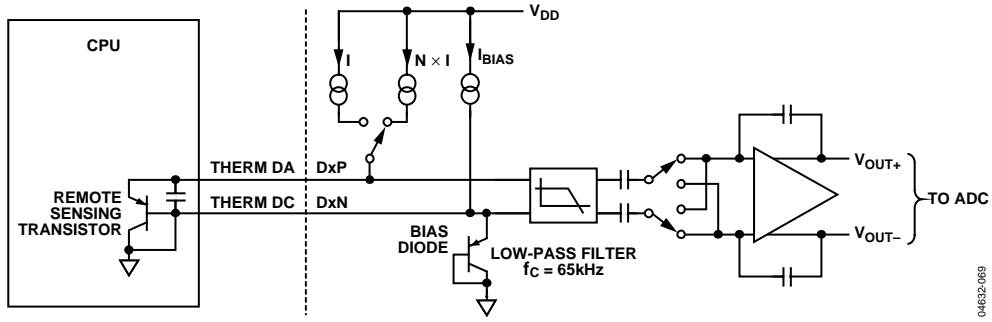

Figure 34. Signal Conditioning for Remote Diode Temperature Sensors

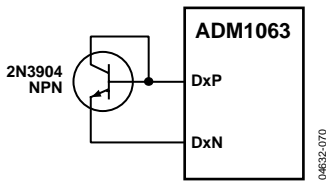

Figure 35. Measuring Temperature Using an NPN Transistor

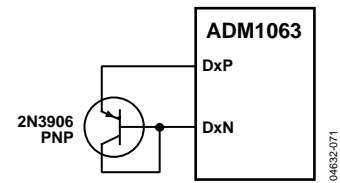

Figure 36. Measuring Temperature Using a PNP Transistor



# APPLICATIONS DIAGRAM

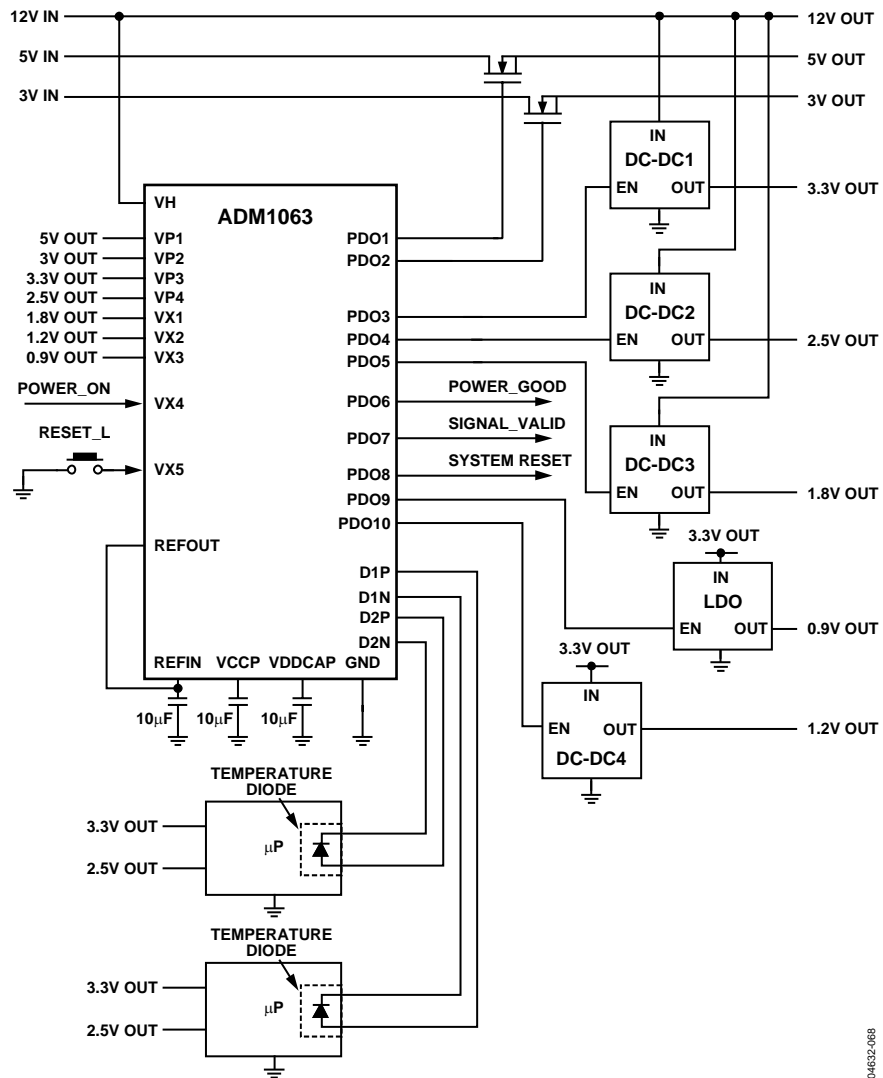

Figure 37. Applications Diagram

04632-068

## COMMUNICATING WITH THE ADM1063

### CONFIGURATION DOWNLOAD AT POWER-UP

The configuration of the ADM1063 (UV/OV thresholds, glitch filter timeouts, PDO configurations, and so on) is dictated by the contents of RAM. The RAM is comprised of digital latches that are local to each of the functions on the device. The latches are double-buffered and have two identical latches, Latch A and Latch B. Therefore, when an update to a function occurs, the contents of Latch A are updated first, and then the contents of Latch B are updated with identical data. The advantages of this architecture are explained in detail in the Updating the Configuration section.

The latches are volatile memory and lose their contents at power-down. Therefore, the configuration in the RAM must be restored at power-up by downloading the contents of the EEPROM (nonvolatile memory) to the local latches. This download occurs in steps, as follows:

1. With no power applied to the device, the PDOs are all high impedance.
2. When 1 V appears on any of the inputs connected to the  $V_{DD}$  arbitrator (VH or VPn), the PDOs are all weakly pulled to GND with a 20 k $\Omega$  impedance.
3. When the supply rises above the undervoltage lockout of the device (UVLO is 2.5 V), the EEPROM starts to download to the RAM.
4. The EEPROM downloads its contents to all Latch As.
5. Once the contents of the EEPROM are completely downloaded to the Latch As, the device controller signals all Latch As to download to all Latch Bs simultaneously, completing the configuration download.
6. At 0.5 ms after the configuration download completes, the first state definition is downloaded from EEPROM into the SE.

Note that any attempt to communicate with the device prior to the completion of the download causes the ADM1063 to issue a no acknowledge (NACK).

### UPDATING THE CONFIGURATION

After power-up, with all the configuration settings loaded from EEPROM into the RAM registers, the user might need to alter the configuration of functions on the ADM1063, such as changing the UV or OV limit of an SFD, changing the fault output of an SFD, or adjusting the rise time delay of one of the PDOs.

The ADM1063 provides several options that allow the user to update the configuration over the SMBus interface. The following options are controlled in the UPDCFG register:

1. Update the configuration in real time. The user writes to RAM across the SMBus and the configuration is updated immediately.
2. Update the Latch As without updating the Latch Bs. With this method, the configuration of the ADM1063 remains unchanged and continues to operate in the original setup until the instruction is given to update the Latch Bs.
3. Change EEPROM register contents without changing the RAM contents, and then download the revised EEPROM contents to the RAM registers. With this method, the configuration of the ADM1063 remains unchanged and continues to operate in the original setup until the instruction is given to update the RAM.

The instruction to download from the EEPROM in Option 3 is also a useful way to restore the original EEPROM contents, if revisions to the configuration are unsatisfactory. For example, if the user needs to alter an OV threshold, this can be done by updating the RAM register as described in Option 1. However, if the user is not satisfied with the change and wants to revert to the original programmed value, then the device controller can issue a command to download the EEPROM contents to the RAM again, as described in Option 3, restoring the ADM1063 to its original configuration.

The topology of the ADM1063 makes this type of operation possible. The local, volatile registers (RAM) are all double-buffered latches. Setting Bit 0 of the UPDCFG register to 1 leaves the double-buffered latches open at all times. If Bit 0 is set to 0, then, when a RAM write occurs across the SMBus, only the first side of the double-buffered latch is written to. The user must then write a 1 to Bit 1 of the UPDCFG register. This generates a pulse to update all the second latches at once. EEPROM writes occur in a similar way.

The final bit in this register can enable or disable EEPROM page erasure. If this bit is set high, the contents of an EEPROM page can all be set to 1. If low, then the contents of a page cannot be erased, even if the command code for page erasure is programmed across the SMBus. The bit map for the UPDCFG register is shown in the [AN-698](#) application note. A flow diagram for download at power-up and subsequent configuration updates is shown in Figure 38.

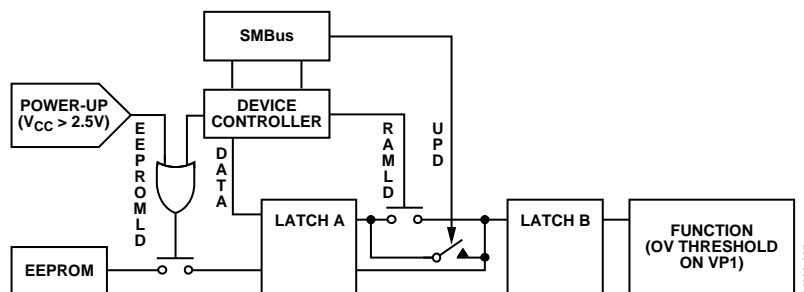

Figure 38. Configuration Update Flow Diagram

## UPDATING THE SEQUENCING ENGINE

Sequencing engine (SE) functions are not updated in the same way as regular configuration latches. The SE has its own dedicated 512-byte EEPROM for storing state definitions, providing 63 individual states, each with a 64-bit word (one state is reserved). At power-up, the first state is loaded from the SE EEPROM into the engine itself. When the conditions of this state are met, the next state is loaded from EEPROM into the engine, and so on. The loading of each new state takes approximately 10  $\mu$ s.

To alter a state, the required changes must be made directly to EEPROM. RAM for each state does not exist. The relevant alterations must be made to the 64-bit word, which is then uploaded directly to EEPROM.

## INTERNAL REGISTERS

The ADM1063 contains a large number of data registers. The principal registers are the address pointer register and the configuration registers.

### Address Pointer Register

This register contains the address that selects one of the other internal registers. When writing to the ADM1063, the first byte of data is always a register address, which is written to the address pointer register.

### Configuration Registers

These registers provide control and configuration for various operating parameters of the ADM1063.

## EEPROM

The ADM1063 has two 512-byte cells of nonvolatile, electrically erasable, programmable, read-only memory (EEPROM) from Register Address 0xF800 to Register Address 0xFBFF. The EEPROM is used for permanent storage of data that is not lost when the ADM1063 is powered down. One EEPROM cell contains the configuration data of the device; the other contains the state definitions for the SE. Although referred to as read-only memory, the EEPROM can be written to, as well as read from, via the serial bus in exactly the same way as the other registers.

The major differences between the EEPROM and other registers are as follows:

- An EEPROM location must be blank before it can be written to. If it contains data, it must first be erased.
- Writing to EEPROM is slower than writing to RAM.
- Writing to the EEPROM should be restricted, because it has a limited write/cycle life of typically 10,000 write operations due to the usual EEPROM wear-out mechanisms.

The first EEPROM is split into 16 (0 to 15) pages of 32 bytes each. Pages 0 to 6, starting at Address 0xF800, hold the configuration data for the applications on the ADM1063 (the SFDs, PDOs, and so on). These EEPROM addresses are the same as the RAM register addresses, prefixed by F8. Page 7 is reserved. Page 8 to Page 15 are for customer use.

Data can be downloaded from EEPROM to RAM in one of the following ways:

- At power-up when Page 0 to Page 6 are downloaded.
- By setting Bit 0 of the UDOWNLD register (0xD8), which performs a user download of Page 0 to Page 6.

## SERIAL BUS INTERFACE

The ADM1063 is controlled via the serial system management bus (SMBus). The ADM1063 is connected to this bus as a slave device, under the control of a master device. It takes approximately 1 ms after power-up for the ADM1063 to download from its EEPROM. Therefore, access to the ADM1063 is restricted until the download is completed.

### Identifying the ADM1063 on the SMBus

The ADM1060 has a 7-bit serial bus slave address. The device is powered up with a default serial bus address. The 5 MSBs of the address are set to 01101, and the 2 LSBs are determined by the logical states of Pin A1 and Pin A0. This allows the connection of four ADM1063s to one SMBus.

The device also has several identification registers (read-only), which can be read across the SMBus. Table 11 lists these registers with their values and functions.

**Table 11. Identification Register Values and Functions**

Name	Address	Value	Function
MANID	0xF4	0x41	Manufacturer ID for Analog Devices
REVID	0xF5	0x02	Silicon revision
MARK1	0xF6	0x00	Software brand
MARK2	0xF7	0x00	Software brand

### General SMBus Timing

Figure 39 to Figure 41 are timing diagrams for general read and write operations using the SMBus. The SMBus specification defines specific conditions for different types of read and write operations, which are discussed in the Write Operations and Read Operations sections.

The general SMBus protocol operates as follows:

1. The master initiates data transfer by establishing a start condition, defined as a high-to-low transition on the serial data-line SDA while the serial clock-line SCL remains high. This indicates that a data stream follows. All slave peripherals connected to the serial bus respond to the start condition and shift in the next eight bits, consisting of a 7-bit slave address (MSB first) plus an R/W bit. This bit determines the direction of the data transfer, that is, whether data is written to or read from the slave device (0 = write, 1 = read).

The peripheral whose address corresponds to the transmitted address responds by pulling the data line low during the low period before the ninth clock pulse, known as the acknowledge bit, and holding it low during the high period of this clock pulse.

All other devices on the bus remain idle while the selected device waits for data to be read from or written to it. If the R/W bit is a 0, the master writes to the slave device. If the R/W bit is a 1, the master reads from the slave device.

2. Data is sent over the serial bus in sequences of nine clock pulses—eight bits of data followed by an acknowledge bit from the slave device. Data transitions on the data line must occur during the low period of the clock signal and remain stable during the high period, because a low-to-high transition when the clock is high might be interpreted as a stop signal. If the operation is a write operation, the first data byte after the slave address is a command byte. This tells the slave device what to expect next. It might be an instruction telling the slave device to expect a block write, or it might simply be a register address that tells the slave where subsequent data is to be written. Because data can flow in only one direction, as defined by the R/W bit, sending a command to a slave device during a read operation is not possible. Before a read operation, it might be necessary to perform a write operation to tell the slave what sort of read operation to expect and/or from which address to read data.
3. When all data bytes have been read or written, stop conditions are established. In write mode, the master pulls the data line high during the 10th clock pulse to assert a stop condition. In read mode, the master device releases the SDA line during the low period before the ninth clock pulse, but the slave device does not pull it low. This is known as a no acknowledge. The master then takes the data line low during the low period before the 10th clock pulse, then high during the 10th clock pulse to assert a stop condition.

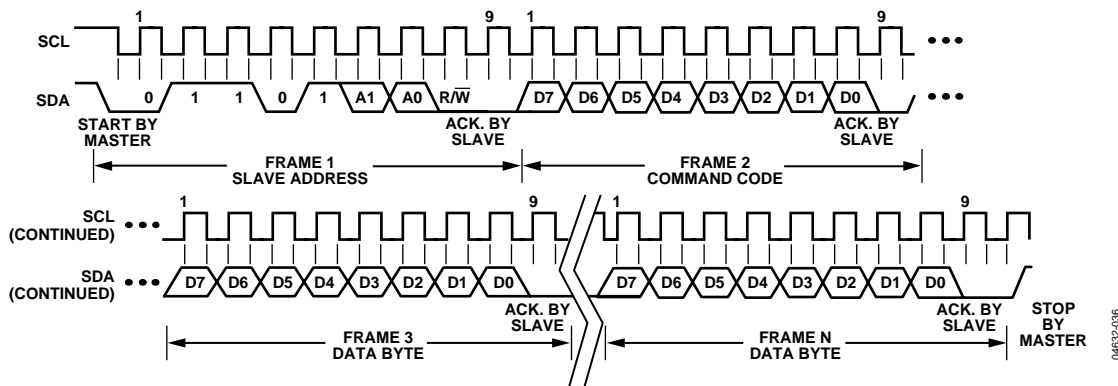

Figure 39. General SMBus Write Timing Diagram

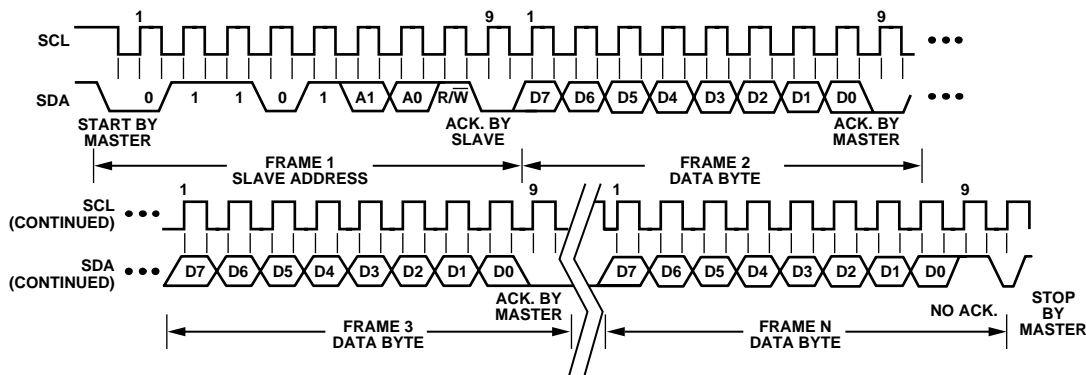

Figure 40. General SMBus Read Timing Diagram

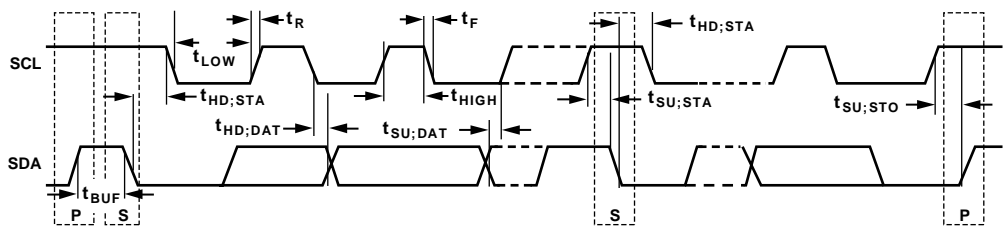

Figure 41. Serial Bus Timing Diagram

**SMBus PROTOCOLS FOR RAM AND EEPROM**

The ADM1063 contains volatile registers (RAM) and nonvolatile registers (EEPROM). User RAM occupies address locations from 0x00 to 0xDF; EEPROM occupies addresses from 0xF800 to 0xFBFF.

Data can be written to and read from both RAM and EEPROM as single data bytes. Data can be written only to unprogrammed EEPROM locations. To write new data to a programmed location, the location’s contents must first be erased. EEPROM erasure cannot be done at the byte level. The EEPROM is arranged as 32 pages of 32 bytes each, and an entire page must be erased.

Page erasure is enabled by setting Bit 2 in the UPDCFG register (Address 0x90) to 1. If this bit is not set, page erasure cannot occur, even if the command byte (0xFE) is programmed across the SMBus.

**WRITE OPERATIONS**

The SMBus specification defines several protocols for different types of read and write operations. The following abbreviations are used in the diagrams:

- S = Start
- P = Stop
- R = Read
- W = Write
- A = Acknowledge
- ̄A = No acknowledge

The ADM1063 uses the following SMBus write protocols.

**Send Byte**

In a send byte operation, the master device sends a single command byte to a slave device, as follows:

1. The master device asserts a start condition on SDA.
2. The master sends the 7-bit slave address followed by the write bit (low).
3. The addressed slave device asserts ACK on SDA.
4. The master sends a command code.
5. The slave asserts ACK on SDA.
6. The master asserts a stop condition on SDA, and the transaction ends.

In the ADM1063, the send byte protocol is used for two purposes:

- To write a register address to RAM for a subsequent single byte read from the same address, or for a block read or a block write starting at that address, as shown in Figure 42.

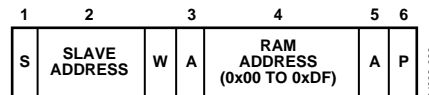

Figure 42. Setting a RAM Address for Subsequent Read

# ADM1063

- To erase a page of EEPROM memory. EEPROM memory can be written to only if it is unprogrammed. Before writing to one or more EEPROM memory locations that are already programmed, the page(s) containing those locations must first be erased. EEPROM memory is erased by writing a command byte.

The master sends a command code that tells the slave device to erase the page. The ADM1063 command code for a page erasure is 0xFE (1111 1110). Note that, for a page erasure to take place, the page address must be given in the previous write word transaction (see the Write Byte/Word section). Also, Bit 2 in the UPDCFG register (Address 0x90) must be set to 1.

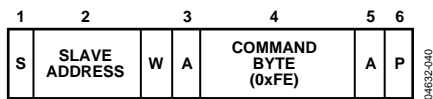

Figure 43. EEPROM Page Erasure

As soon as the ADM1063 receives the command byte, page erasure begins. The master device can send a stop command as soon as it sends the command byte. Page erasure takes approximately 20 ms. If the ADM1063 is accessed before erasure is complete, it responds with a no acknowledge (NACK).

## Write Byte/Word

In a write byte/word operation, the master device sends a command byte and one or two data bytes to the slave device, as follows:

- The master device asserts a start condition on SDA.
- The master sends the 7-bit slave address followed by the write bit (low).
- The addressed slave device asserts ACK on SDA.
- The master sends a command code.
- The slave asserts ACK on SDA.
- The master sends a data byte.
- The slave asserts ACK on SDA.
- The master sends a data byte or asserts a stop condition.
- The slave asserts ACK on SDA.
- The master asserts a stop condition on SDA to end the transaction.

In the ADM1063, the write byte/word protocol is used for three purposes:

- To write a single byte of data to RAM. In this case, the command byte is the RAM addresses from 0x00 to 0xDF and the only data byte is the actual data, as shown in Figure 44.

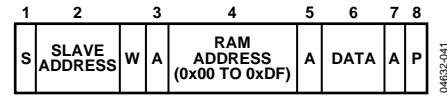

Figure 44. Single Byte Write to RAM

- To set up a 2-byte EEPROM address for a subsequent read, write, block read, block write, or page erase. In this case, the command byte is the high byte of the EEPROM addresses from 0xF8 to 0xFB. The only data byte is the low byte of the EEPROM address, as shown in Figure 45.

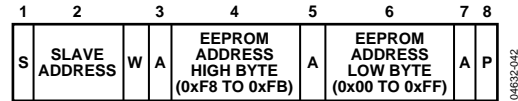

Figure 45. Setting an EEPROM Address

Note that for page erasure, because a page consists of 32 bytes, only the 3 MSBs of the address low byte are important. The lower five bits of the EEPROM address low byte specify the addresses within a page and are ignored during an erase operation.

- To write a single byte of data to EEPROM. In this case, the command byte is the high byte of the EEPROM addresses from 0xF8 to 0xFB. The first data byte is the low byte of the EEPROM address, and the second data byte is the actual data, as shown in Figure 46.

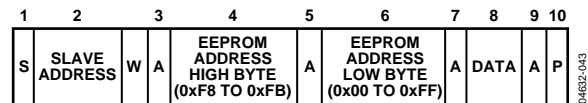

Figure 46. Single Byte Write to EEPROM

## Block Write

In a block write operation, the master device writes a block of data to a slave device. The start address for a block write must have been set previously. In the ADM1063, a send byte operation sets a RAM address, and a write byte/word operation sets an EEPROM address, as follows:

- The master device asserts a start condition on SDA.
- The master sends the 7-bit slave address followed by the write bit (low).
- The addressed slave device asserts ACK on SDA.

4. The master sends a command code that tells the slave device to expect a block write. The ADM1063 command code for a block write is 0xFC (1111 1100).
5. The slave asserts ACK on SDA.
6. The master sends a data byte that tells the slave device how many data bytes are being sent. The SMBus specification allows a maximum of 32 data bytes in a block write.
7. The slave asserts ACK on SDA.
8. The master sends N data bytes.
9. The slave asserts ACK on SDA after each data byte.
10. The master asserts a stop condition on SDA to end the transaction.

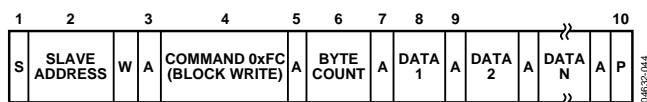

Figure 47. Block Write to EEPROM or RAM

Unlike some EEPROM devices that limit block writes to within a page boundary, there is no limitation on the start address when performing a block write to EEPROM, except

- There must be at least N locations from the start address to the highest EEPROM address (0xFBFF) to avoid writing to invalid addresses.
- If the addresses cross a page boundary, both pages must be erased before programming.

Note that the ADM1063 features a clock extend function for writes to EEPROM. Programming an EEPROM byte takes approximately 250  $\mu$ s, which would limit the SMBus clock for repeated or block write operations. The ADM1063 pulls SCL low and extends the clock pulse when it cannot accept any more data.

## READ OPERATIONS

The ADM1063 uses the following SMBus read protocols.

### Receive Byte

In a receive byte operation, the master device receives a single byte from a slave device, as follows:

1. The master device asserts a start condition on SDA.
2. The master sends the 7-bit slave address followed by the read bit (high).
3. The addressed slave device asserts ACK on SDA.
4. The master receives a data byte.

5. The master asserts a no acknowledge on SDA.
6. The master asserts a stop condition on SDA, and the transaction ends.

In the ADM1063, the receive byte protocol is used to read a single byte of data from a RAM or EEPROM location whose address has previously been set by a send byte or write byte/word operation, as shown in Figure 48.

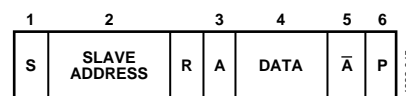

Figure 48. Single Byte Read from EEPROM or RAM

### Block Read

In a block read operation, the master device reads a block of data from a slave device. The start address for a block read must have been set previously. In the ADM1063, this is done by a send byte operation to set a RAM address, or a write byte/word operation to set an EEPROM address. The block read operation itself consists of a send byte operation that sends a block read command to the slave, immediately followed by a repeated start and a read operation that reads out multiple data bytes, as follows:

1. The master device asserts a start condition on SDA.
2. The master sends the 7-bit slave address followed by the write bit (low).
3. The addressed slave device asserts ACK on SDA.
4. The master sends a command code that tells the slave device to expect a block read. The ADM1063 command code for a block read is 0xFD (1111 1101).
5. The slave asserts ACK on SDA.
6. The master asserts a repeat start condition on SDA.
7. The master sends the 7-bit slave address followed by the read bit (high).
8. The slave asserts ACK on SDA.
9. The ADM1063 sends a byte-count data byte that tells the master how many data bytes to expect. The ADM1063 always returns 32 data bytes (0x20), which is the maximum allowed by the SMBus 1.1 specification.
10. The master asserts ACK on SDA.
11. The master receives 32 data bytes.
12. The master asserts ACK on SDA after each data byte.
13. The master asserts a stop condition on SDA to end the transaction.

# ADM1063

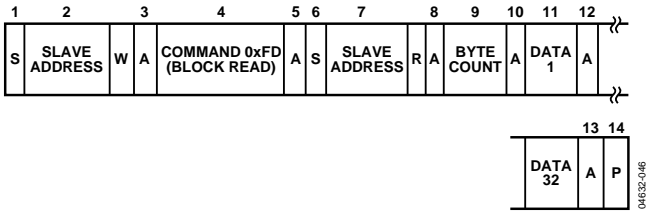

Figure 49. Block Read from EEPROM or RAM

## Error Correction

The ADM1063 provides the option of issuing a packet error correction (PEC) byte after a write to RAM, a write to EEPROM, a block write to RAM/EEPROM, or a block read from RAM/EEPROM. This enables the user to verify that the data received by or sent from the ADM1063 is correct. The PEC byte is an optional byte sent after that last data byte has been written to or read from the ADM1063. The protocol is as follows:

1. The ADM1063 issues a PEC byte to the master. The master checks the PEC byte and issues another block read if the PEC byte is incorrect.
2. A no acknowledge (NACK) is generated after the PEC byte to signal the end of the read.

Note that the PEC byte is calculated using CRC-8. The frame check sequence (FCS) conforms to CRC-8 by the polynomial

$$C(x) = x^8 + x^2 + x^1 + 1$$

See the SMBus 1.1 specification for details.

An example of a block read with the optional PEC byte is shown in Figure 50.

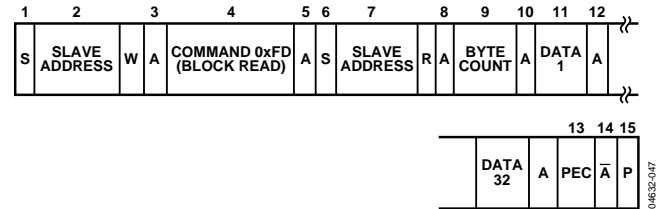
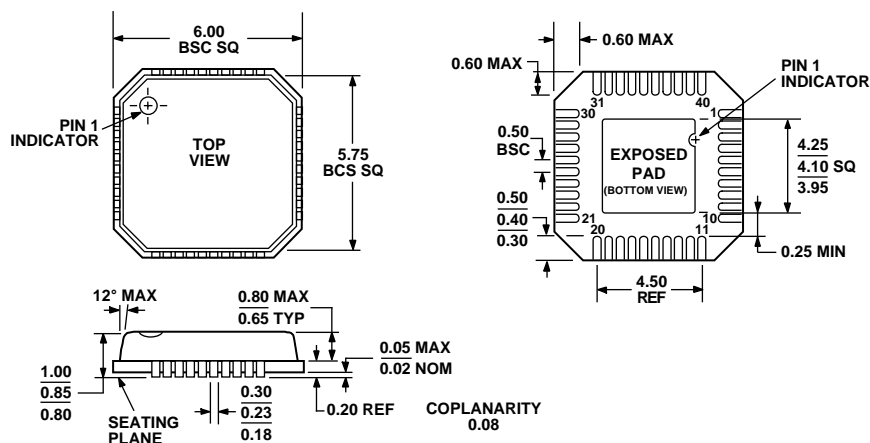

Figure 50. Block Read from EEPROM or RAM with PEC



# OUTLINE DIMENSIONS



COMPLIANT TO JEDEC STANDARDS MO-220-VJJD-2

Figure 51. 40-Lead Lead Frame Chip Scale Package [LFCSP\_VQ]  
6 × 6 mm Body, Very Thin Quad  
(CP-40)  
Dimensions shown in millimeters

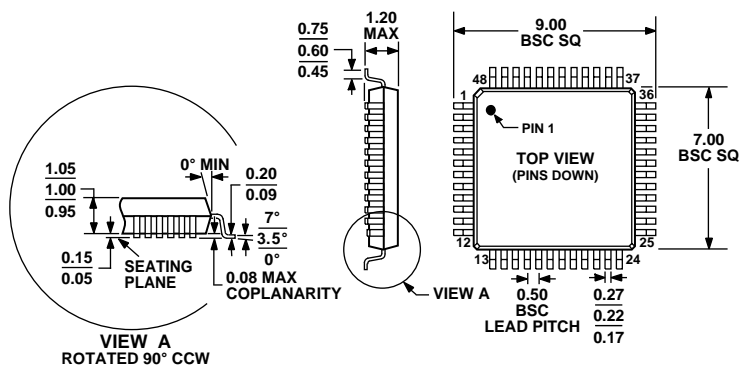

COMPLIANT TO JEDEC STANDARDS MS-026ABC

Figure 52. 48-Lead Thin Plastic Quad Flat Package [TQFP]  
(SU-48)  
Dimensions shown in millimeters

# ADM1063

## ORDERING GUIDE

Model	Temperature Range	Package Description	Package Option
ADM1063ACP	-40°C to +85°C	40-Lead LFCSP_VQ	CP-40
ADM1063ACP-REEL7	-40°C to +85°C	40-Lead LFCSP_VQ	CP-40
ADM1063ACPZ <sup>1</sup>	-40°C to +85°C	40-Lead LFCSP_VQ	CP-40
ADM1063ACPZ-REEL7 <sup>1</sup>	-40°C to +85°C	40-Lead LFCSP_VQ	CP-40
ADM1063ASU	-40°C to +85°C	48-Lead TQFP	SU-48
ADM1063ASU-REEL7	-40°C to +85°C	48-Lead TQFP	SU-48
ADM1063ASUZ <sup>1</sup>	-40°C to +85°C	48-Lead TQFP	SU-48
ADM1063ASUZ-REEL7 <sup>1</sup>	-40°C to +85°C	48-Lead TQFP	SU-48
EVAL-ADM1063LFEB		ADM1063 Evaluation Kit (LFCSP Version)	
EVAL-ADM1063TQEB		ADM1063 Evaluation Kit (TQFP Version)	

<sup>1</sup> Z = Pb-free part.

**NOTES**

**ADM1063**

**NOTES**