

**FEATURES**

**0.5  $\Omega$  typical on resistance**  
**0.7  $\Omega$  maximum on resistance at 85°C**  
**1.65 V to 3.6 V operation**  
**High current carrying capability: 300 mA continuous**  
**Rail-to-rail switching operation**  
**Fast switching times <20 ns**  
**Typical power consumption (<0.1  $\mu$ W)**  
**1.3 mm  $\times$  1.6 mm mini LFCSP package**

**APPLICATIONS**

**Cellular phones**  
**PDA's**  
**MP3 players**  
**Power routing**  
**Battery-powered systems**  
**PCMCIA cards**  
**Modems**  
**Audio and video signal routing**  
**Communication systems**

**GENERAL DESCRIPTION**

The ADG824 is a low voltage CMOS device containing two independently selectable single-pole, double throw (SPDT) switches. This device offers ultralow on resistance of less than 0.7  $\Omega$  over the full temperature range. The ADG824 is fully specified for 3.3 V, 2.5 V, and 1.8 V supply operation.

Each switch conducts equally well in both directions when on, and has an input signal range that extends to the supplies. The ADG824 exhibits break-before-make switching action.

The low on resistance of the ADG824 makes this device ideal for audio switching. In addition, a data rate of 180 Mbps makes the device suitable for USB low speed (1.5 Mbps) and full speed (12 Mbps) data switching.

The ADG824 is available in a 1.3 mm  $\times$  1.6 mm, 10-lead mini LFCSP package.

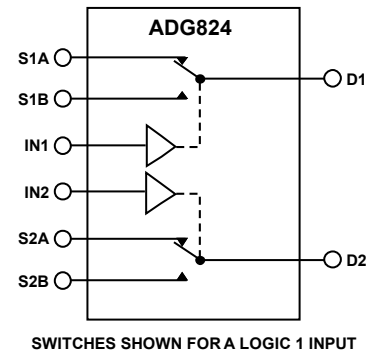
**FUNCTIONAL BLOCK DIAGRAM***Figure 1.***PRODUCT HIGHLIGHTS**

1. <0.7  $\Omega$  over the full temperature range of -40°C to +85°C.
2. Single 1.65 V to 3.6 V operation.
3. 1.8 V logic compatible.
4. High current carrying capability (300 mA continuous current at 3.3 V).
5. Low THD + N (0.06% typical).
6. 1.3 mm  $\times$  1.6 mm mini LFCSP package.

**Rev. 0**

Information furnished by Analog Devices is believed to be accurate and reliable. However, no responsibility is assumed by Analog Devices for its use, nor for any infringements of patents or other rights of third parties that may result from its use. Specifications subject to change without notice. No license is granted by implication or otherwise under any patent or patent rights of Analog Devices. Trademarks and registered trademarks are the property of their respective owners.

## TABLE OF CONTENTS

Features .....	1	ESD Caution.....	6
Applications.....	1	Pin Configuration and Function Descriptions.....	7
Functional Block Diagram .....	1	Typical Performance Characteristics .....	8
General Description .....	1	Test Circuits.....	11
Product Highlights .....	1	Terminology .....	13
Revision History .....	2	Outline Dimensions .....	14
Specifications.....	3	Ordering Guide .....	14
Absolute Maximum Ratings.....	6		

## REVISION HISTORY

4/08—Revision 0: Initial Version

## SPECIFICATIONS

$V_{DD} = 2.7\text{ V to }3.6\text{ V}$ ,  $GND = 0\text{ V}$ , unless otherwise noted.

**Table 1.**

Parameter	+25°C	−40°C to +85°C	Unit	Test Conditions/Comments
<b>ANALOG SWITCH</b>				
Analog Signal Range		0 to $V_{DD}$	V	
On Resistance, $R_{ON}$	0.5		$\Omega$ typ	$V_{DD} = 2.7\text{ V}$ , $V_S = 0\text{ V to }V_{DD}$ , $I_{DS} = 100\text{ mA}$ ; see Figure 19
	0.65	0.7	$\Omega$ max	
On Resistance Match Between Channels, $\Delta R_{ON}$	0.003		$\Omega$ typ	$V_{DD} = 2.7\text{ V}$ , $V_S = 0.65\text{ V}$ , $I_{DS} = 100\text{ mA}$
		0.01	$\Omega$ max	
On Resistance Flatness, $R_{FLAT(ON)}$	0.13		$\Omega$ typ	$V_{DD} = 2.7\text{ V}$ , $V_S = 0\text{ V to }V_{DD}$ , $I_{DS} = 100\text{ mA}$
		0.2	$\Omega$ max	
<b>LEAKAGE CURRENTS</b>				
Source Off Leakage, $I_S$ (Off)	$\pm 0.2$		nA typ	$V_{DD} = 3.6\text{ V}$ $V_S = 0.6\text{ V}/3.3\text{ V}$ , $V_D = 3.3\text{ V}/0.6\text{ V}$ ; see Figure 20
Channel On Leakage, $I_D$ , $I_S$ (On)	$\pm 0.2$		nA typ	$V_S = V_D = 0.6\text{ V or }3.3\text{ V}$ ; see Figure 21
<b>DIGITAL INPUTS</b>				
Input High Voltage, $V_{INH}$		1.3	V min	
Input Low Voltage, $V_{INL}$		0.8	V max	
Input Current				
$I_{INL}$ or $I_{INH}$	0.005		$\mu\text{A}$ typ	$V_{IN} = V_{INL}$ or $V_{INH}$
		$\pm 0.1$	$\mu\text{A}$ max	$V_{IN} = V_{INL}$ or $V_{INH}$
Digital Input Capacitance, $C_{IN}$	2.7		pF typ	
<b>DYNAMIC CHARACTERISTICS<sup>1</sup></b>				
$t_{ON}$	7		ns typ	$R_L = 50\ \Omega$ , $C_L = 35\text{ pF}$
	9.5	10.8	ns max	$V_S = 2\text{ V}/0\text{ V}$ ; see Figure 22
$t_{OFF}$	6		ns typ	$R_L = 50\ \Omega$ , $C_L = 35\text{ pF}$
	7.7	8.6	ns max	$V_S = 2\text{ V}$ ; see Figure 22
Break-Before-Make Time Delay, $t_{BBM}$	3.5		ns typ	$R_L = 50\ \Omega$ , $C_L = 35\text{ pF}$
		2	ns min	$V_{S1} = V_{S2} = 2\text{ V}$ ; see Figure 23
Charge Injection, $Q_{INJ}$	27		pC typ	$V_S = 1.5\text{ V}$ , $R_S = 0\ \Omega$ , $C_L = 1\text{ nF}$ ; see Figure 24
Off Isolation	−71		dB typ	$R_L = 50\ \Omega$ , $C_L = 5\text{ pF}$ , $f = 100\text{ kHz}$ ; see Figure 25
Channel-to-Channel Crosstalk	−90		dB typ	S1A to S2A/S1B to S2B, $R_L = 50\ \Omega$ , $C_L = 5\text{ pF}$ , $f = 100\text{ kHz}$ ; see Figure 26
	−67		dB typ	S1A to S1B/S2A to S2B, $R_L = 50\ \Omega$ , $C_L = 5\text{ pF}$ , $f = 100\text{ kHz}$ ; see Figure 27
Total Harmonic Distortion, THD + N	0.06		%	$R_L = 33\ \Omega$ , $f = 20\text{ Hz to }20\text{ kHz}$ , $V_S = 2\text{ V p-p}$
Insertion Loss	−0.05		dB typ	$R_L = 50\ \Omega$ , $C_L = 5\text{ pF}$ ; see Figure 28
−3 dB Bandwidth	90		MHz typ	$R_L = 50\ \Omega$ , $C_L = 5\text{ pF}$ ; see Figure 28
$C_S$ (Off)	25		pF typ	
$C_D$ , $C_S$ (On)	58		pF typ	
<b>POWER REQUIREMENTS</b>				
$I_{DD}$	0.003		$\mu\text{A}$ typ	$V_{DD} = 3.6\text{ V}$ Digital inputs = 0 V or 3.6 V
		1	$\mu\text{A}$ max	

<sup>1</sup> Guaranteed by design; not subject to production test.

# ADG824

$V_{DD} = 2.5 \text{ V} \pm 0.2 \text{ V}$ ,  $GND = 0 \text{ V}$ , unless otherwise noted.

**Table 2.**

Parameter	+25°C	-40°C to +85°C	Unit	Test Conditions/Comments
<b>ANALOG SWITCH</b>				
Analog Signal Range		0 to $V_{DD}$	V	
On Resistance, $R_{ON}$	0.65		$\Omega$ typ	$V_{DD} = 2.3 \text{ V}$ , $V_S = 0 \text{ V to } V_{DD}$ , $I_{DS} = 100 \text{ mA}$ ; see Figure 19
	0.78	0.83	$\Omega$ max	
On Resistance Match Between Channels, $\Delta R_{ON}$	0.005		$\Omega$ typ	$V_{DD} = 2.3 \text{ V}$ , $V_S = 0.7 \text{ V}$ , $I_{DS} = 100 \text{ mA}$
		0.01	$\Omega$ max	
On Resistance Flatness, $R_{FLAT(ON)}$	0.2		$\Omega$ typ	$V_{DD} = 2.3 \text{ V}$ , $V_S = 0 \text{ V to } V_{DD}$ , $I_{DS} = 100 \text{ mA}$
		0.3	$\Omega$ max	
<b>LEAKAGE CURRENTS</b>				
Source Off Leakage, $I_S$ (Off)	$\pm 0.2$		nA typ	$V_{DD} = 2.7 \text{ V}$ $V_S = 0.6 \text{ V}/2.4 \text{ V}$ , $V_D = 2.4 \text{ V}/0.6 \text{ V}$ ; see Figure 20
Channel On Leakage, $I_D$ , $I_S$ (On)	$\pm 0.2$		nA typ	$V_S = V_D = 0.6 \text{ V or } 2.4 \text{ V}$ ; see Figure 21
<b>DIGITAL INPUTS</b>				
Input High Voltage, $V_{INH}$		1.3	V min	
Input Low Voltage, $V_{INL}$		0.7	V max	
Input Current $I_{INL}$ or $I_{INH}$	0.005		$\mu\text{A}$ typ	$V_{IN} = V_{INL}$ or $V_{INH}$
		$\pm 0.1$	$\mu\text{A}$ max	$V_{IN} = V_{INL}$ or $V_{INH}$
Digital Input Capacitance, $C_{IN}$	2.7		pF typ	
<b>DYNAMIC CHARACTERISTICS<sup>1</sup></b>				
$t_{ON}$	9		ns typ	$R_L = 50 \Omega$ , $C_L = 35 \text{ pF}$
	11.5	12.4	ns max	$V_S = 1.5 \text{ V}/0 \text{ V}$ ; see Figure 22
$t_{OFF}$	6		ns typ	$R_L = 50 \Omega$ , $C_L = 35 \text{ pF}$
	7.4	8	ns max	$V_S = 1.5 \text{ V}$ ; see Figure 22
Break-Before-Make Time Delay, $t_{BBM}$	5		ns typ	$R_L = 50 \Omega$ , $C_L = 35 \text{ pF}$
		3	ns min	$V_{S1} = V_{S2} = 1.5 \text{ V}$ ; see Figure 23
Charge Injection, $Q_{INJ}$	21		pC typ	$V_S = 1.5 \text{ V}$ , $R_S = 0 \Omega$ , $C_L = 1 \text{ nF}$ ; see Figure 24
Off Isolation	-71		dB typ	$R_L = 50 \Omega$ , $C_L = 5 \text{ pF}$ , $f = 100 \text{ kHz}$ ; see Figure 25
Channel-to-Channel Crosstalk	-90		dB typ	S1A to S2A/S1B to S2B, $R_L = 50 \Omega$ , $C_L = 5 \text{ pF}$ , $f = 100 \text{ kHz}$ ; see Figure 26
	-71		dB typ	S1A to S1B/S2A to S2B, $R_L = 50 \Omega$ , $C_L = 5 \text{ pF}$ , $f = 100 \text{ kHz}$ ; see Figure 27
Total Harmonic Distortion, THD + N	0.1		%	$R_L = 33 \Omega$ , $f = 20 \text{ Hz to } 20 \text{ kHz}$ , $V_S = 1.5 \text{ V p-p}$
Insertion Loss	-0.065		dB typ	$R_L = 50 \Omega$ , $C_L = 5 \text{ pF}$ ; see Figure 28
-3 dB Bandwidth	90		MHz typ	$R_L = 50 \Omega$ , $C_L = 5 \text{ pF}$ ; see Figure 28
$C_S$ (Off)	25		pF typ	
$C_D$ , $C_S$ (On)	60		pF typ	
<b>POWER REQUIREMENTS</b>				
$I_{DD}$	0.003		$\mu\text{A}$ typ	$V_{DD} = 2.7 \text{ V}$ Digital inputs = 0 V or 2.7 V
		1	$\mu\text{A}$ max	

<sup>1</sup> Guaranteed by design; not subject to production test.

$V_{DD} = 1.65\text{ V}$  to  $1.95\text{ V}$ ,  $GND = 0\text{ V}$ , unless otherwise noted.

**Table 3.**

Parameter	+25°C	–40°C to +85°C	Unit	Test Conditions/Comments
<b>ANALOG SWITCH</b>				
Analog Signal Range		0 to $V_{DD}$	V	
On Resistance, $R_{ON}$	1.3 1.7 2.5	2.1 3	$\Omega$ typ $\Omega$ max $\Omega$ max	$V_{DD} = 1.8\text{ V}$ , $V_S = 0\text{ V}$ to $V_{DD}$ , $I_{DS} = 100\text{ mA}$ ; see Figure 19
On Resistance Match Between Channels, $\Delta R_{ON}$	0.01		$\Omega$ typ	$V_{DD} = 1.65\text{ V}$ , $V_S = 0\text{ V}$ to $V_{DD}$ , $I_{DS} = 100\text{ mA}$ ; see Figure 19 $V_{DD} = 1.65\text{ V}$ , $V_S = 0.7\text{ V}$ , $I_{DS} = 100\text{ mA}$
<b>LEAKAGE CURRENTS</b>				
Source Off Leakage, $I_S$ (Off)	$\pm 0.2$		nA typ	$V_{DD} = 1.95\text{ V}$ $V_S = 0.6\text{ V}/1.65\text{ V}$ , $V_D = 1.65\text{ V}/0.6\text{ V}$ ; see Figure 20
Channel On Leakage, $I_D$ , $I_S$ (On)	$\pm 0.2$		nA typ	$V_S = V_D = 0.6\text{ V}$ or $1.65\text{ V}$ ; see Figure 21
<b>DIGITAL INPUTS</b>				
Input High Voltage, $V_{INH}$		$0.65 V_{DD}$	V min	
Input Low Voltage, $V_{INL}$		$0.35 V_{DD}$	V max	
Input Current $I_{INL}$ or $I_{INH}$	0.005	$\pm 0.1$	$\mu\text{A}$ typ $\mu\text{A}$ max	$V_{IN} = V_{INL}$ or $V_{INH}$ $V_{IN} = V_{INL}$ or $V_{INH}$
Digital Input Capacitance, $C_{IN}$	2.7		pF typ	
<b>DYNAMIC CHARACTERISTICS<sup>1</sup></b>				
$t_{ON}$	13 18.6	19.3	ns typ ns max	$R_L = 50\ \Omega$ , $C_L = 35\text{ pF}$ $V_S = 1.2\text{ V}/0\text{ V}$ ; see Figure 22
$t_{OFF}$	7 9.8	10.2	ns typ ns max	$R_L = 50\ \Omega$ , $C_L = 35\text{ pF}$ $V_S = 1.2\text{ V}$ ; see Figure 22
Break-Before-Make Time Delay, $t_{BBM}$	7.5	5	ns typ ns min	$R_L = 50\ \Omega$ , $C_L = 35\text{ pF}$ $V_{S1} = V_{S2} = 1.2\text{ V}$ ; see Figure 23
Charge Injection, $Q_{INJ}$	15		pC typ	$V_S = 1\text{ V}$ , $R_S = 0\ \Omega$ , $C_L = 1\text{ nF}$ ; see Figure 24
Off Isolation	–71		dB typ	$R_L = 50\ \Omega$ , $C_L = 5\text{ pF}$ , $f = 100\text{ kHz}$ ; see Figure 25
Channel-to-Channel Crosstalk	–90		dB typ	S1A to S2A/S1B to S2B, $R_L = 50\ \Omega$ , $C_L = 5\text{ pF}$ , $f = 100\text{ kHz}$ ; see Figure 26
	–71		dB typ	S1A to S1B/S2A to S2B, $R_L = 50\ \Omega$ , $C_L = 5\text{ pF}$ , $f = 100\text{ kHz}$ ; see Figure 27
Total Harmonic Distortion, THD + N	0.4		%	$R_L = 33\ \Omega$ , $f = 20\text{ Hz}$ to $20\text{ kHz}$ , $V_S = 1.2\text{ V p-p}$
Insertion Loss	–0.1		dB typ	$R_L = 50\ \Omega$ , $C_L = 5\text{ pF}$ ; see Figure 28
–3 dB Bandwidth	90		MHz typ	$R_L = 50\ \Omega$ , $C_L = 5\text{ pF}$ ; see Figure 28
$C_S$ (Off)	26		pF typ	
$C_D$ , $C_S$ (On)	61		pF typ	
<b>POWER REQUIREMENTS</b>				
$I_{DD}$	0.003	1	$\mu\text{A}$ typ $\mu\text{A}$ max	$V_{DD} = 1.95\text{ V}$ Digital inputs = $0\text{ V}$ or $1.95\text{ V}$

<sup>1</sup> Guaranteed by design; not subject to production test.

## ABSOLUTE MAXIMUM RATINGS

T<sub>A</sub> = 25°C, unless otherwise noted.

Table 4.

Parameter	Rating
V <sub>DD</sub> to GND	−0.3 V to +4.6 V
Analog Inputs <sup>1</sup>	−0.3 V to V <sub>DD</sub> + 0.3 V
Digital Inputs <sup>1</sup>	−0.3 V to +4.6 V or 10 mA, whichever occurs first
Peak Current, Sx or Dx Pins	Pulsed at 1 ms, 10% duty cycle max
3.3 V Operation	500 mA
2.5 V Operation	460 mA
1.8 V Operation	420 mA
Continuous Current, Sx or Dx Pins	
3.3 V Operation	300 mA
2.5 V Operation	275 mA
1.8 V Operation	250 mA
Operating Temperature Range	−40°C to +85°C
Storage Temperature Range	−65°C to +150°C
Junction Temperature	150°C
Mini LFCSP Package	
θ <sub>JA</sub> Thermal Impedance (4-Layer Board)	131.6°C/W
Reflow Soldering (Pb-Free)	
Peak Temperature	260°C
Time at Peak Temperature	10 sec to 40 sec

<sup>1</sup> Overvoltages at the INx, Sx, or Dx pins are clamped by internal diodes. Current should be limited to the maximum ratings given.

Stresses above those listed under Absolute Maximum Ratings may cause permanent damage to the device. This is a stress rating only; functional operation of the device at these or any other conditions above those indicated in the operational section of this specification is not implied. Exposure to absolute maximum rating conditions for extended periods may affect device reliability.

Only one absolute maximum rating may be applied at any one time.

### ESD CAUTION



**ESD (electrostatic discharge) sensitive device.** Charged devices and circuit boards can discharge without detection. Although this product features patented or proprietary protection circuitry, damage may occur on devices subjected to high energy ESD. Therefore, proper ESD precautions should be taken to avoid performance degradation or loss of functionality.

## PIN CONFIGURATION AND FUNCTION DESCRIPTIONS

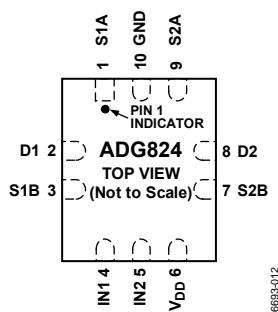

Figure 2. Pin Configuration

Table 5. Pin Function Descriptions

Pin No.	Mnemonic	Description
1	S1A	Source Terminal. This pin can be an input or an output.
2	D1	Drain Terminal. This pin can be an input or an output.
3	S1B	Source Terminal. This pin can be an input or an output.
4	IN1	Logic Control Input. This pin controls Switch S1A and Switch S1B to D1.
5	IN2	Logic Control Input. This pin controls Switch S2A and Switch S2B to D2.
6	V <sub>DD</sub>	Most Positive Power Supply Potential.
7	S2B	Source Terminal. This pin can be an input or an output.
8	D2	Drain Terminal. This pin can be an input or an output.
9	S2A	Source Terminal. This pin can be an input or an output.
10	GND	Ground (0 V) Reference.

Table 6. ADG824 Truth Table

Logic (IN1/IN2)	Switch A (S1A or S2A)	Switch B (S1B or S2B)
0	Off	On
1	On	Off

## TYPICAL PERFORMANCE CHARACTERISTICS

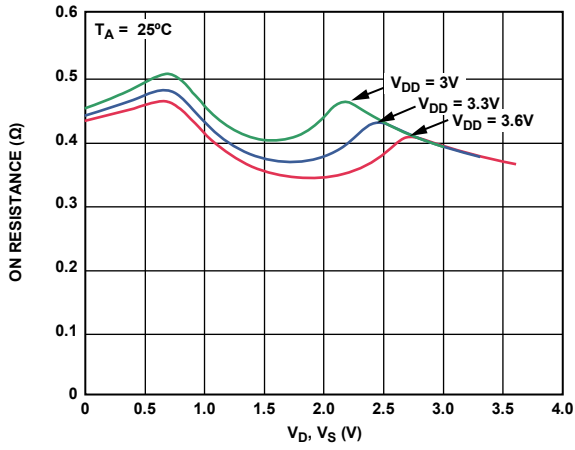

Figure 3. On Resistance vs.  $V_D$  ( $V_S$ ),  $V_{DD} = 3.3\text{ V} \pm 0.3\text{ V}$

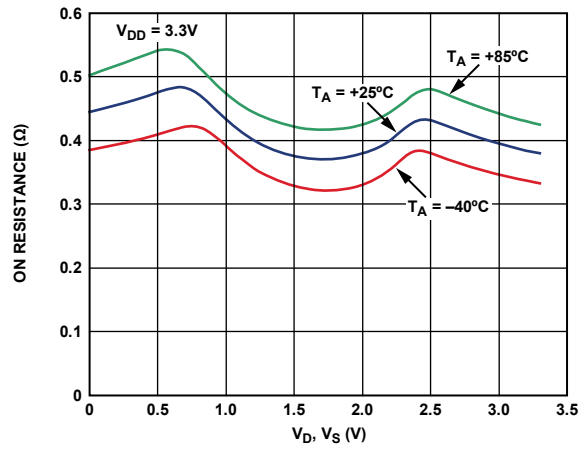

Figure 6. On Resistance vs.  $V_D$  ( $V_S$ ) for Different Temperatures,  $V_{DD} = 3.3\text{ V}$

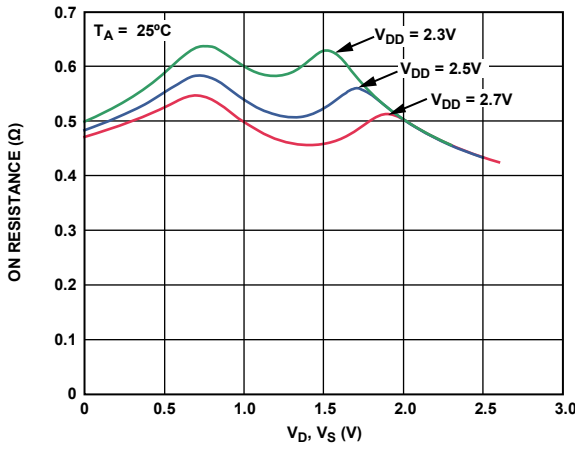

Figure 4. On Resistance vs.  $V_D$  ( $V_S$ ),  $V_{DD} = 2.5\text{ V} \pm 0.2\text{ V}$

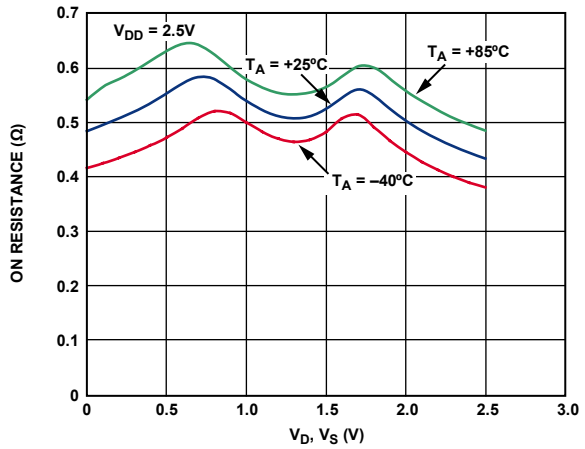

Figure 7. On Resistance vs.  $V_D$  ( $V_S$ ) for Different Temperatures,  $V_{DD} = 2.5\text{ V}$

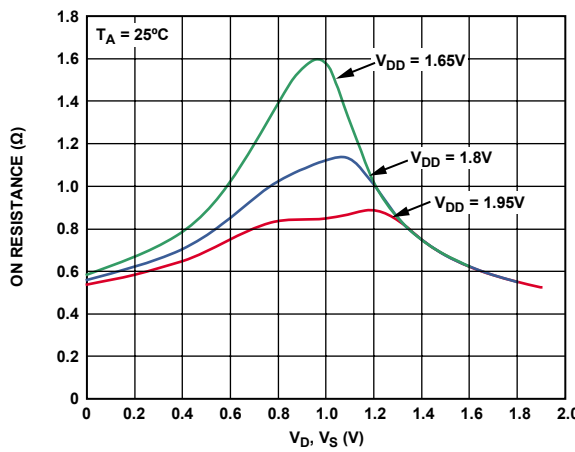

Figure 5. On Resistance vs.  $V_D$  ( $V_S$ ),  $V_{DD} = 1.8\text{ V} \pm 0.15\text{ V}$

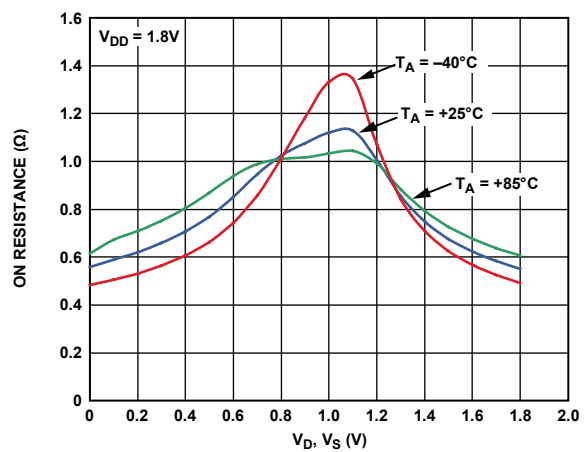

Figure 8. On Resistance vs.  $V_D$  ( $V_S$ ) for Different Temperatures,  $V_{DD} = 1.8\text{ V}$



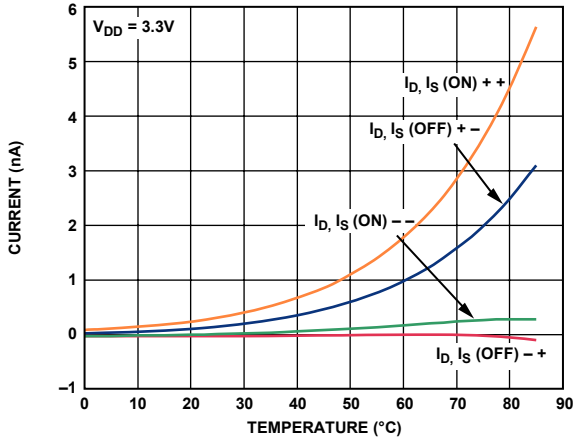

Figure 9. Leakage Current vs. Temperature,  $V_{DD} = 3.3V$

06693-028

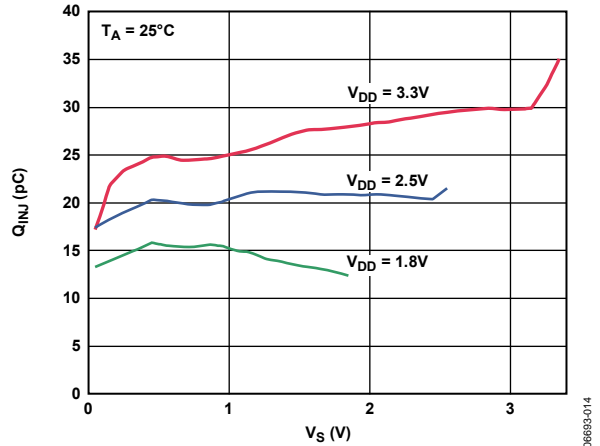

Figure 12. Charge Injection vs. Source Voltage

06693-014

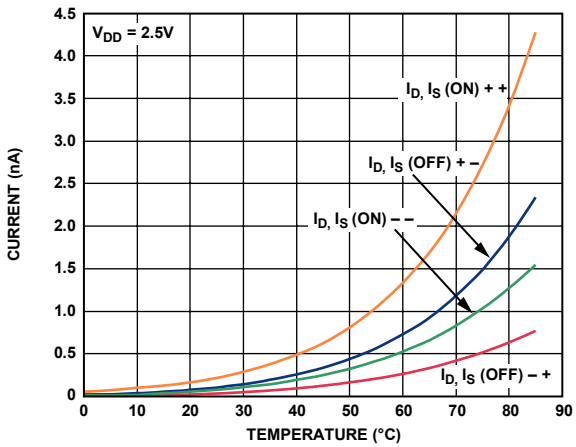

Figure 10. Leakage Current vs. Temperature,  $V_{DD} = 2.5V$

06693-017

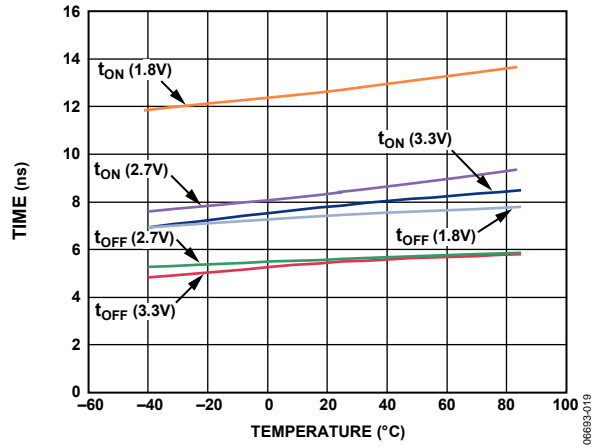

Figure 13.  $t_{ON}/t_{OFF}$  Times vs. Temperature

06693-019

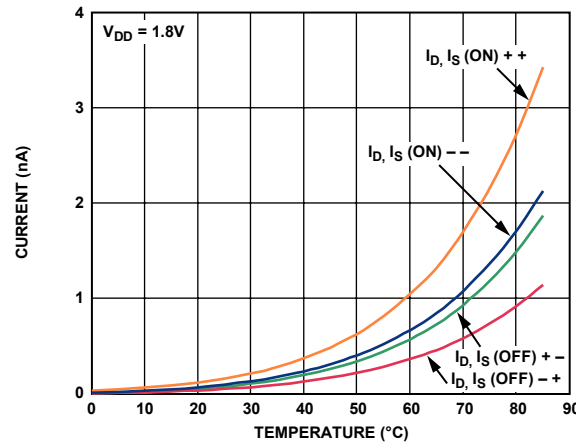

Figure 11. Leakage Current vs. Temperature,  $V_{DD} = 1.8V$

06693-027

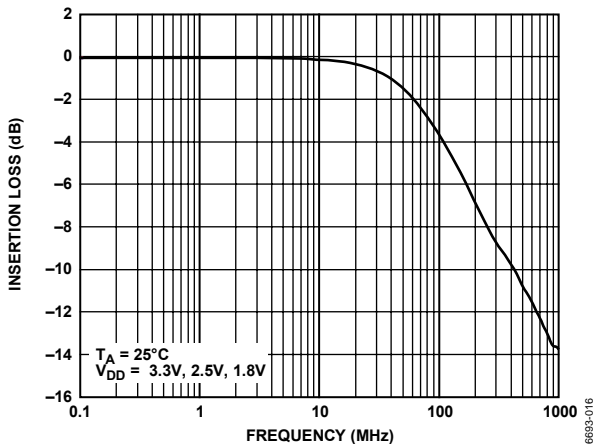

Figure 14. Bandwidth

06693-016

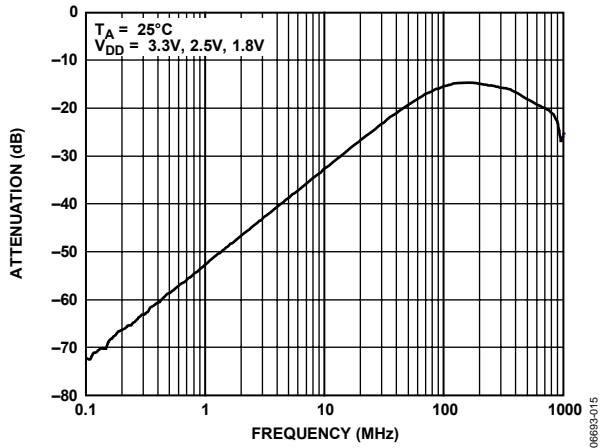

Figure 15. Off Isolation vs. Frequency

06693-015

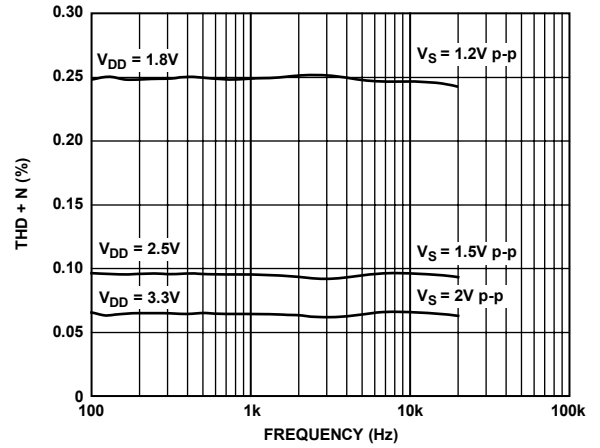

Figure 17. Total Harmonic Distortion + Noise vs. Frequency

06693-013

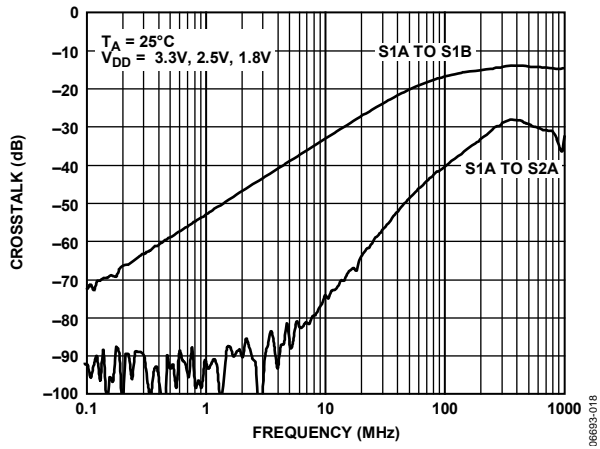

Figure 16. Crosstalk vs. Frequency

06693-018

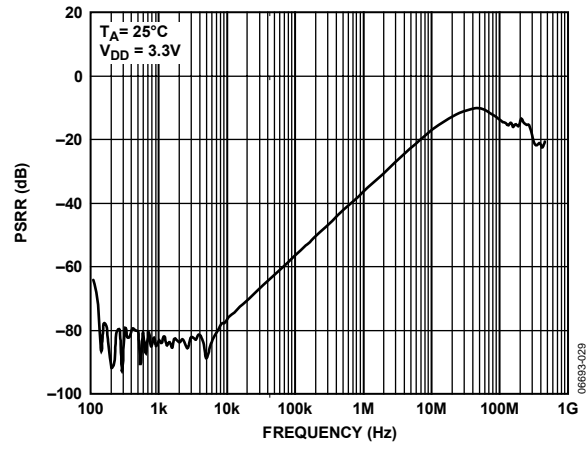

Figure 18. PSRR vs. Frequency

06693-029

TEST CIRCUITS

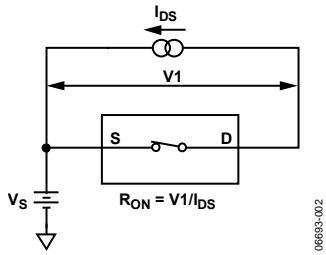

Figure 19. On Resistance

06693-002

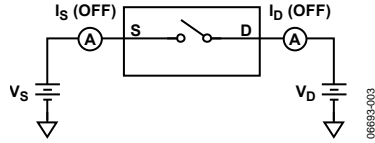

Figure 20. Off Leakage

06693-003

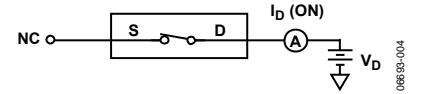

Figure 21. On Leakage

06693-004

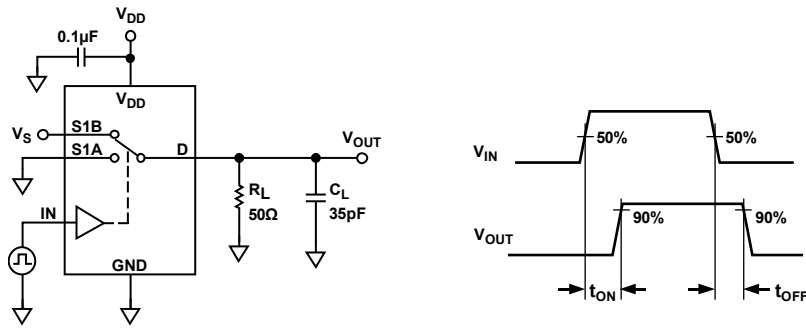

Figure 22. Switching Times,  $t_{ON}$ ,  $t_{OFF}$

06693-005

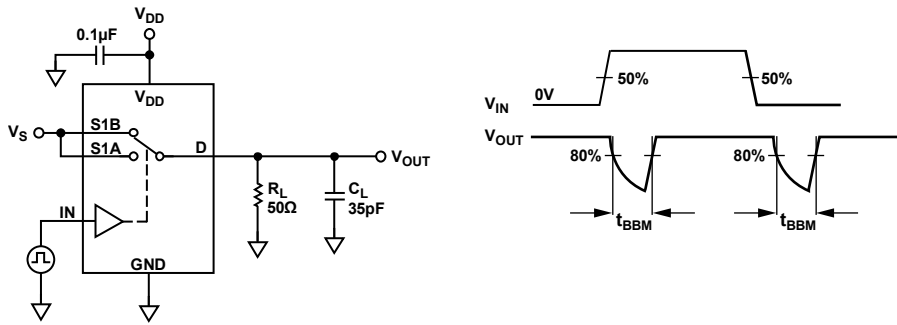

Figure 23. Break-Before-Make Time Delay,  $t_{BBM}$

06693-006

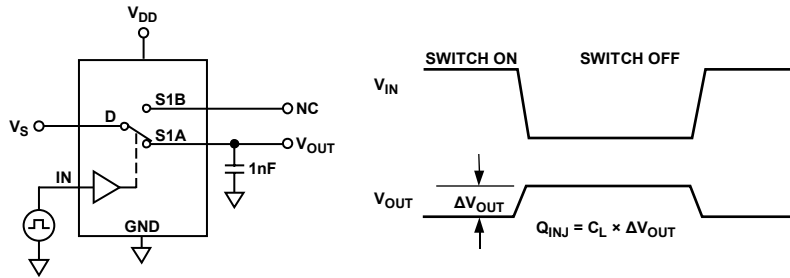

Figure 24. Charge Injection

06693-007

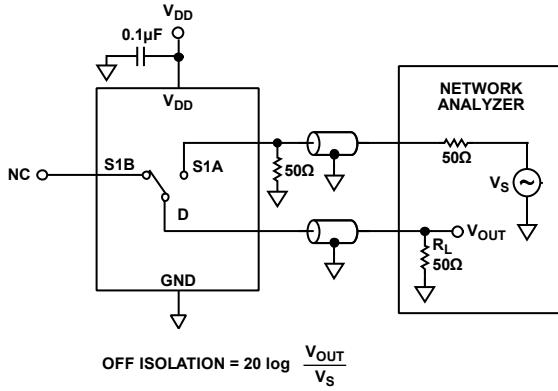

Figure 25. Off Isolation

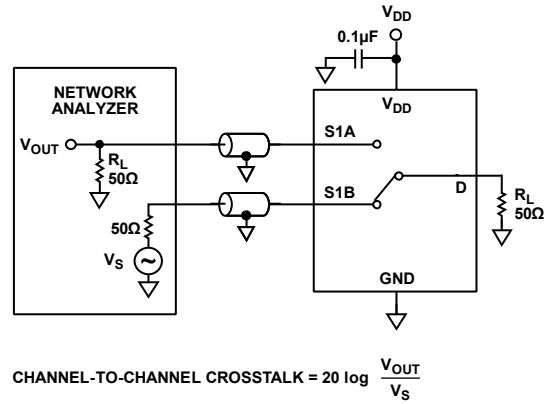

Figure 27. Channel-to-Channel Crosstalk (S1A to S1B/S2A to S2B)

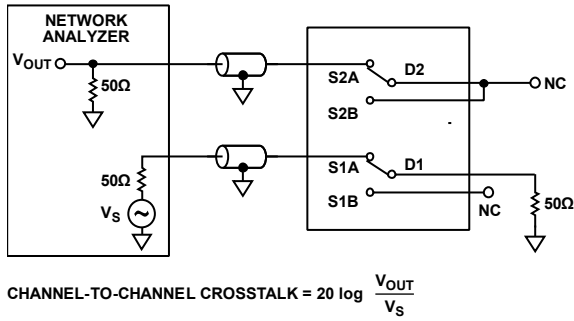

Figure 26. Channel-to-Channel Crosstalk (S1A to S2A/S1B to S2B)

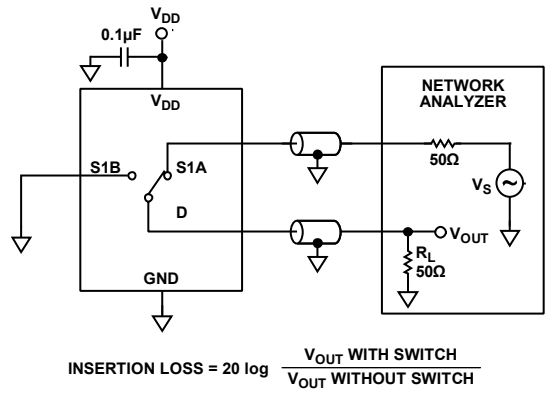

Figure 28. Bandwidth

06693-008

06693-010

06693-011

06693-009

## TERMINOLOGY

### $I_{DD}$

Positive supply current.

### $V_D$ ( $V_S$ )

Analog voltage on Terminal D and Terminal S.

### $R_{ON}$

Ohmic resistance between Terminal D and Terminal S.

### $R_{FLAT}$ (**On**)

The difference between the maximum and minimum values of on resistance as measured on the switch.

### $\Delta R_{ON}$

On resistance match between any two channels.

### $I_S$ (**Off**)

Source leakage current with the switch off.

### $I_D$ (**Off**)

Drain leakage current with the switch off.

### $I_D, I_S$ (**On**)

Channel leakage current with the switch on.

### $V_{INL}$

Maximum input voltage for Logic 0.

### $V_{INH}$

Minimum input voltage for Logic 1.

### $I_{INL}$ ( $I_{INH}$ )

Input current of the digital input.

### $C_S$ (**Off**)

Off switch source capacitance. Measured with reference to ground.

### $C_D, C_S$ (**On**)

On switch capacitance. Measured with reference to ground.

### $C_{IN}$

Digital input capacitance.

### $t_{ON}$

Delay time between the 50% and 90% points of the digital input and switch on condition.

### $t_{OFF}$

Delay time between the 50% and 90% points of the digital input and switch off condition.

### $t_{BBM}$

On or off time measured between the 80% points of both switches when switching from one to another.

### **Charge Injection**

Measure of the glitch impulse transferred from the digital input to the analog output during on/off switching.

### **Off Isolation**

Measure of unwanted signal coupling through an off switch.

### **Crosstalk**

Measure of unwanted signal that is coupled from one channel to another as a result of parasitic capacitance.

### **-3 dB Bandwidth**

Frequency at which the output is attenuated by 3 dB.

### **Insertion Loss**

The loss due to the on resistance of the switch.

### **THD + N**

Ratio of the harmonics amplitude plus noise of a signal to the fundamental.

# ADG824

## OUTLINE DIMENSIONS

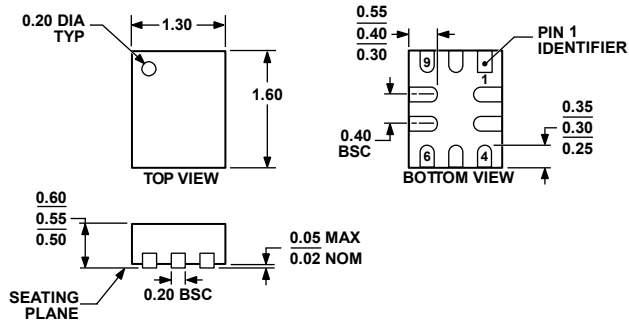

033007-A

Figure 29. 10-Lead Lead Frame Chip Scale Package (LFCSP\_UQ)  
 1.3 mm × 1.6 mm Body, Ultra Thin Quad  
 (CP-10-10)  
 Dimensions shown in millimeters

## ORDERING GUIDE

Model	Temperature Range	Package Description	Package Option	Branding
ADG824BCPZ-REEL <sup>1</sup>	-40°C to +85°C	10-Lead Mini Lead Frame Chip Scale Package (LFCSP_UQ)	CP-10-10	A
ADG824BCPZ-REEL <sup>7</sup>	-40°C to +85°C	10-Lead Mini Lead Frame Chip Scale Package (LFCSP_UQ)	CP-10-10	A
EVAL-ADG824EBZ <sup>1</sup>	-40°C to +85°C	Evaluation Board		

<sup>1</sup> Z = RoHS Compliant Part.

**NOTES**

**ADG824**

**NOTES**