

FEATURES

- Ease-of-use, 16-bit complete data acquisition system
- Simultaneous sampling selection of 2, 4, 6, and 8 channels
- Differential input voltage range: ± 20.48 V maximum
- High impedance 8-channel input: >500 M Ω
- High input common-mode rejection: 95.0 dB
- User-programmable input ranges
- On-chip 4.096 V reference and buffer
- No latency/pipeline delay (SAR architecture)
- Serial 4-wire 1.8 V to 5 V SPI-/SPORT-compatible interface
- 40-lead LFCSP package (6 mm \times 6 mm)
- -40°C to $+85^{\circ}\text{C}$ industrial temperature range

APPLICATIONS

- Multichannel data acquisition and system monitoring
- Process control
- Power line monitoring
- Automated test equipment
- Patient monitoring
- Spectrum analysis
- Instrumentation

GENERAL DESCRIPTION

The [ADAS3023](#) is a complete 16-bit successive approximation-based analog-to-digital data acquisition system. This device is capable of simultaneously sampling up to 500 kSPS for two channels, 250 kSPS for four channels, 167 kSPS for six channels, and 125 kSPS for eight channels manufactured on the Analog Devices, Inc., proprietary *i*CMOS[®] high voltage industrial process technology.

The [ADAS3023](#) integrates eight channels of low leakage track and hold, a programmable gain instrumentation amplifier (PGIA) stage with a high common-mode rejection offering four differential input ranges, a precision low drift 4.096 V reference and buffer, and a 16-bit charge redistribution successive approximation register (SAR) analog-to-digital converter (ADC). The [ADAS3023](#) can resolve differential input ranges of up to ± 20.48 V when using ± 15 V supplies.

FUNCTIONAL BLOCK DIAGRAM

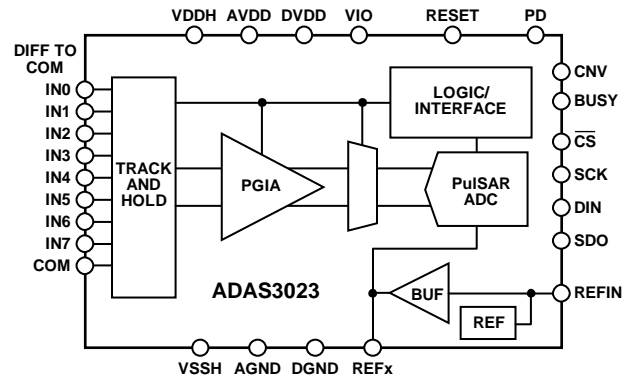

Figure 1.

The [ADAS3023](#) simplifies design challenges by eliminating signal buffering, level shifting, amplification and attenuation, common-mode rejection, settling time, or any of the other analog signal conditioning challenges, yet allows for smaller form factor, faster time to market, and lower costs.

The [ADAS3023](#) is factory calibrated and its operation is specified from -40°C to $+85^{\circ}\text{C}$.

Table 1. Typical Input Range Selection

Single-Ended Signals ¹	Input Range, V_{IN}
0 V to 1 V	± 1.28 V
0 V to 2.5 V	± 2.56 V
0 V to 5 V	± 5.12 V
0 V to 10 V	± 10.24 V

¹ See Figure 39 and Figure 40 in the Analog Inputs section for more information.

TABLE OF CONTENTS

Features	1	Typical Application Connection Diagram	21
Applications	1	Analog Inputs	21
Functional Block Diagram	1	Voltage Reference Input/Output	22
General Description	1	Power Supply	24
Revision History	2	Power Dissipation Modes	24
Specifications	3	Conversion Modes	25
Timing Specifications	6	Digital Interface	26
Absolute Maximum Ratings	9	Conversion Control	26
ESD Caution	9	RESET and Power-Down (PD) Inputs	26
Pin Configuration and Function Descriptions	10	Serial Data Interface	27
Typical Performance Characteristics	12	General Timing	28
Terminology	17	Configuration Register	29
Theory of Operation	19	Packaging and Ordering Information	30
Overview	19	Outline Dimensions	30
Operation	19	Ordering Guide	30
Transfer Functions	20		

REVISION HISTORY

5/13—Revision 0: Initial Version

SPECIFICATIONS

VDDH = 15 V ± 5%, VSSH = -15 V ± 5%, AVDD = DVDD = 5 V ± 5%; VIO = 1.8 V to AVDD, Internal Reference $V_{REF} = 4.096$ V, $f_s = 500$ kSPS, all specifications T_{MIN} to T_{MAX} , unless otherwise noted.

Table 2.

Parameter	Test Conditions/Comments	Min	Typ	Max	Unit ¹
RESOLUTION		16			Bits
ANALOG INPUT (IN0 to IN7, COM)					
Input Impedance	Z_{IN}	500			M Ω
Operating Input Voltage Range ²	V_{IN} , on any single pin	VSSH + 2.5		VDDH - 2.5	V
Differential Input Voltage Ranges, V_{IN}	$V_{INX} - COM$				
	PGIA gain = 0.2, $V_{IN} = 40.96$ V p-p	-5 V_{REF}		+5 V_{REF}	V
	PGIA gain = 0.4, $V_{IN} = 20.48$ V p-p	-2.5 V_{REF}		+2.5 V_{REF}	V
	PGIA gain = 0.8, $V_{IN} = 10.24$ V p-p	-1.25 V_{REF}		+1.25 V_{REF}	V
	PGIA gain = 1.6, $V_{IN} = 5.12$ V p-p	-0.625 V_{REF}		+0.625 V_{REF}	V
THROUGHPUT					
Conversion Rate	Two channels	0		500	kSPS
	Four channels	0		250	kSPS
	Six channels	0		167	kSPS
	Eight channels	0		125	kSPS
Transient Response ³	Full-scale step			820	ns
DC ACCURACY					
No Missing Codes		16			Bits
Integral Linearity Error	PGIA gain = 0.2, 0.4, or 0.8, COM = 0 V	-2.5	±1	+2.5	LSB
	PGIA gain = 1.6, COM = 0 V	-3	±1	+3	LSB
Differential Linearity Error	All PGIA gains, COM = 0 V	-0.95	±0.5	+1.25	LSB
Transition Noise	PGIA gain = 0.2 or 0.4		6		LSB
	PGIA gain = 0.8		7		LSB
	PGIA gain = 1.6		10		LSB
Gain Error ⁴	External reference, all PGIA gains	-0.075		+0.075	%FS
Gain Error Match, Delta Mean	External reference, all PGIA gains	-0.05		+0.05	%FS
Gain Error Temperature Drift	External reference, PGIA gain = 0.2, 0.4, or 0.8			1	ppm/°C
	External reference, PGIA gain = 1.6			2	ppm/°C
Offset Error ⁴	External reference, PGIA gain = 0.2	-65	-35	+12	LSB
	External reference, PGIA gain = 0.4	-85	-45	+12	LSB
	External reference, PGIA gain = 0.8	-10	0	+10	LSB
	External reference, PGIA gain = 1.6	0	130	250	LSB
Offset Error Match, Delta Mean	External reference, PGIA gain = 0.2, 0.4, 0.8, or 1.6	-15	±1	+15	LSB
Offset Error Temperature Drift	External reference, PGIA gain = 0.2 or 0.4, IN0 to IN7	0	0.5	2	ppm/°C
	External reference, PGIA gain = 0.8, IN0 to IN7	0	1.5	3	ppm/°C
	External reference, PGIA gain = 1.6, IN0 to IN7	0	2.5	5	ppm/°C
AC ACCURACY ⁵					
Signal-to-Noise Ratio	Internal reference $f_{IN} = 1$ kHz, COM = 0 V				
	PGIA gain = 0.2	90.0	91.5		dB
	PGIA gain = 0.4	89.5	91.0		dB
	PGIA gain = 0.8	87.5	89.0		dB
	PGIA gain = 1.6	85.0	86.5		dB
Signal-to-Noise + Distortion (SINAD)	$f_{IN} = 1$ kHz, two, four, six, and eight channels				
	PGIA gain = 0.2	89.5	91.0		dB
	PGIA gain = 0.4	89.0	90.5		dB
	PGIA gain = 0.8	87.0	88.5		dB
	PGIA gain = 1.6	84.0	86.0		dB

Parameter	Test Conditions/Comments	Min	Typ	Max	Unit ¹
Dynamic Range	$f_{IN} = 1 \text{ kHz}$, -60 dB input PGIA gain = 0.2 PGIA gain = 0.4 PGIA gain = 0.8 PGIA gain = 1.6	91.0 90.5 88.0 86.0	92 91.5 89.5 87.0		dB dB dB dB
Total Harmonic Distortion	$f_{IN} = 1 \text{ kHz}$, all PGIA gains		-100		dB
Spurious-Free Dynamic Range	$f_{IN} = 1 \text{ kHz}$, all PGIA gains		105		dB
Channel-to-Channel Crosstalk	$f_{IN} = 1 \text{ kHz}$, all channels inactive		95		dB
DC Common-Mode Rejection Ratio (CMRR)	All channels PGIA gain = 0.2 PGIA gain = 0.4 PGIA gain = 0.8 PGIA gain = 1.6		95.0 95.0 95.0 95.0		dB dB dB dB
-3 dB Input Bandwidth	-40 dBFS		8		MHz
INTERNAL REFERENCE					
REFx Pins					
Output Voltage	$T_A = 25^\circ\text{C}$	4.088	4.096	4.104	V
Output Current	$T_A = 25^\circ\text{C}$		250		μA
Temperature Drift	REFEN bit = 1 REFEN bit = 0, REFIN pin = 2.5V		± 5 ± 1		ppm/ $^\circ\text{C}$ ppm/ $^\circ\text{C}$
Line Regulation					
Internal Reference	AVDD = 5 V \pm 5%		20		$\mu\text{V/V}$
Buffer Only	AVDD = 5 V \pm 5%		4		ppm
REFIN Output Voltage ⁶	$T_A = 25^\circ\text{C}$	2.495	2.5	2.505	V
Turn-On Settling Time	$C_{REFIN}, C_{REF1}, C_{REF2} = 10 \mu\text{F} 0.1 \mu\text{F}$		100		ms
EXTERNAL REFERENCE					
Voltage Range	REFEN bit = 0 REFx input, REFIN = 0 V REFIN input (buffered)	4.000	4.096	4.104	V V
Current Drain	$f_s = 500 \text{ kSPS}$		100		μA
DIGITAL INPUTS					
Logic Levels					
V_{IL}	$V_{IO} > 3 \text{ V}$	-0.3		$+0.3 \times V_{IO}$	V
V_{IH}	$V_{IO} > 3 \text{ V}$	$0.7 \times V_{IO}$		$V_{IO} + 0.3$	V
V_{IL}	$V_{IO} \leq 3 \text{ V}$	-0.3		$+0.1 \times V_{IO}$	V
V_{IH}	$V_{IO} \leq 3 \text{ V}$	$0.9 \times V_{IO}$		$V_{IO} + 0.3$	V
I_{IL}		-1		+1	μA
I_{IH}		-1		+1	μA
DIGITAL OUTPUTS⁷					
Data Format			Twos complement		
V_{OL}	$I_{SINK} = +500 \mu\text{A}$			0.4	V
V_{OH}	$I_{SOURCE} = -500 \mu\text{A}$	$V_{IO} - 0.3$			V
POWER SUPPLIES					
VIO		1.8		AVDD + 0.3	V
AVDD		4.75	5	5.25	V
DVDD		4.75	5	5.25	V
VDDH	VDDH > input voltage + 2.5 V	14.25	15	15.75	V
VSSH	VSSH < input voltage - 2.5 V	-15.75	-15	-14.25	V

Parameter	Test Conditions/Comments	Min	Typ	Max	Unit ¹
I _{VDDH}	Two channels		5.0	5.5	mA
	Four channels		6.0	7.0	mA
	Six channels		9.5	10.5	mA
	Eight channels		9.5	10.5	mA
	PD = 1			10.0	μA
I _{VSSH}	Two channels	-5.5	+5.0		mA
	Four channels	-6.5	+5.5		mA
	Six channels	-10.0	-8.5		mA
	Eight channels	-10.0	-8.5		mA
	All PGIA gains, PD = 1		10.0		μA
I _{AVDD}	All PGIA gains, PD = 0, reference buffer enabled		16.0	17.0	mA
	All PGIA gains, PD = 0, reference buffer disabled			15.5	mA
I _{DVDD}	All PGIA gains, PD = 1		100		μA
	All PGIA gains, PD = 0		2.5	3	mA
I _{VIO}	All PGIA gains, PD = 1		100		μA
	All PGIA gains, PD = 0, VIO = 3.3 V			1.0	mA
Power Supply Sensitivity	All PGIA gains, PD = 1		10.0		μA
	External reference, T _A = 25°C				
	PGIA gain = 0.2 or 0.4, VDDH/VSSH = ±15 V ± 5%		±0.1		LSB
	PGIA gain = 0.8, VDDH/VSSH = ±15 V ± 5%		±0.2		LSB
	PGIA gain = 1.6, VDDH/VSSH = ±15 V ± 5%		±0.4		LSB
	PGIA gain = 0.2 or 0.4, AVDD, DVDD = ±5 V ± 5%		±1.0		LSB
TEMPERATURE RANGE	T _{MIN} to T _{MAX}	-40		+85	°C

¹ The LSB unit means least significant bit. The weight of the LSB, referred to input, changes depending on the input voltage range. See the Programmable Gain section for the LSB size.

² Full-scale differential input ranges of ±2.56 V, ±5.12 V, ±10.24 V, and ±20.48 V are set by the configuration register.

³ If using the external multiplexer in front of the ADAS3023, it must be switched at least 820 ns prior to the rising edge of CNV.

⁴ See the Terminology section. These parameters are specified at ambient temperature with an external reference. All other influences of temperature and supply are measured and specified separately.

⁵ All ac specifications expressed in decibels are referenced to the full-scale input range (FSR) and are tested with an input signal at 0.5 dB below full scale, unless otherwise specified.

⁶ This is the output from the internal band gap reference.

⁷ There is no pipeline delay. Conversion results are available immediately after a conversion is completed.

TIMING SPECIFICATIONS

VDDH = 15 V ± 5%, VSSH = -15 V ± 5%, AVDD = DVDD = 5 V ± 5%, VIO = 1.8 V to AVDD, Internal Reference $V_{REF} = 4.096$ V, $f_s = 500$ kSPS, all specifications T_{MIN} to T_{MAX} , unless otherwise noted.¹

Table 3.

Parameter	Symbol	Min	Typ	Max	Unit
TIME BETWEEN CONVERSIONS	t_{CYC}				
Warp ² Mode, CMS = 0					
Two Channels		2.0		1000	μs
Four Channels		4.0		1000	μs
Six Channels		6.0		1000	μs
Eight Channels		8.0		1000	μs
Normal Mode (Default), CMS = 1					
Two Channels		2.1		1000	μs
Four Channels		4.1		1000	μs
Six Channels		6.1		1000	μs
Eight Channels		8.1		1000	μs
CONVERSION TIME: CNV RISING EDGE TO DATA AVAILABLE	t_{CONV}				
Warp Mode, CMS = 0					
Two Channels			1485	1630	ns
Four Channels			2850	3340	ns
Six Channels			4215	5000	ns
Eight Channels			5580	6700	ns
Normal Mode (Default), CMS = 1					
Two Channels			1575	1720	ns
Four Channels			2940	3430	ns
Six Channels			4305	5090	ns
Eight Channels			5670	6790	ns
CNV					
Pulse Width	t_{CNVH}	10			ns
CNV High to Hold Time (Aperture Delay)	t_{AD}		2		ns
CNV High to BUSY/SDO2 Delay	t_{CBD}			520	ns
SCK					
Period	t_{SCK}	$t_{SDOV} + 3$			ns
Low Time	t_{SCKL}	5			ns
High Time	t_{SCKH}	5			ns
SCK Falling Edge to Data Remains Valid	t_{SDOH}	4			ns
SCK Falling Edge to Data Valid Delay	t_{SDOV}				
VIO > 4.5 V				12	ns
VIO > 3 V				18	ns
VIO > 2.7 V				24	ns
VIO > 2.3 V				25	ns
VIO > 1.8 V				37	ns
CS/RESET/PD					
\overline{CS} /RESET/PD Low to SDO D15 MSB Valid	t_{EN}				
VIO > 4.5 V				7	ns
VIO > 3 V				8	ns
VIO > 2.7 V				10	ns
VIO > 2.3 V				15	ns
VIO > 1.8 V				20	ns
\overline{CS} /RESET/PD High to SDO High Impedance	t_{DIS}			25	ns
CNV Rising to \overline{CS}	t_{CCS}	5			ns

Parameter	Symbol	Min	Typ	Max	Unit
DIN					
DIN Valid Setup Time from SCK Falling Edge	t_{DINS}	4			ns
DIN Valid Hold Time from SCK Falling Edge	t_{DINH}	4			ns
RESET/PD HIGH PULSE	t_{RH}	5			ns

¹ See Figure 2 and Figure 3 for load conditions.

² Exceeding the maximum time has an effect on the accuracy of the conversion (see the Conversion Modes section).

Circuit and Voltage Diagrams

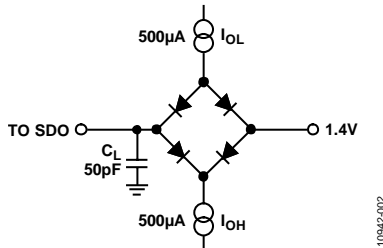
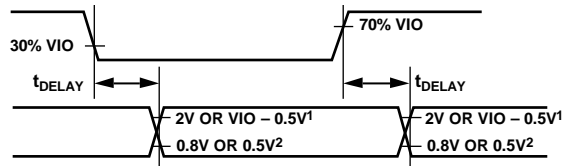

Figure 2. Load Circuit for Digital Interface Timing



¹ $12V$ IF $V_{IO} > 2.5V$; $V_{IO} - 0.5V$ IF $V_{IO} < 2.5V$.
² $0.8V$ IF $V_{IO} > 2.5V$; $0.5V$ IF $V_{IO} < 2.5V$.

Figure 3. Voltage Levels for Timing

Timing Diagrams

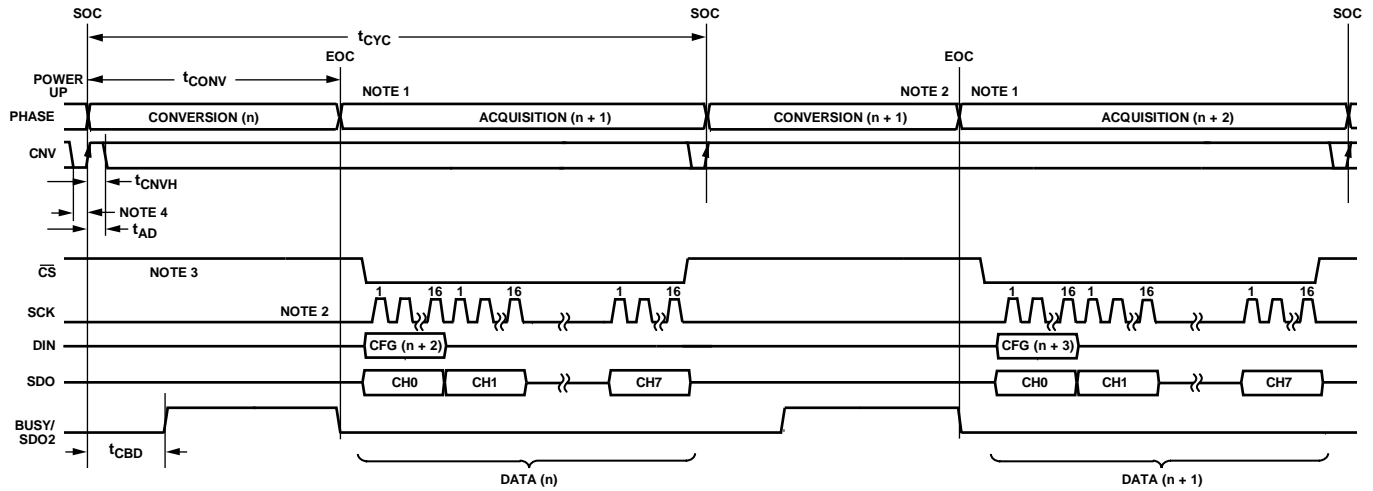

- NOTES
1. DATA ACCESS CAN ONLY OCCUR AFTER CONVERSION. BOTH CONVERSION RESULT AND THE CFG REGISTER ARE UPDATED AT THE END OF THE CONVERSION (EOC).
 2. A TOTAL OF 16 SCK FALLING EDGES ARE REQUIRED FOR CONVERSION RESULT. AN ADDITIONAL 16 EDGES AFTER THE LAST CONVERSION RESULT ON BUSY READS BACK THE CFG ASSOCIATED WITH CONVERSION.
 3. \overline{CS} CAN BE HELD LOW OR CONNECTED TO CNV. \overline{CS} IS SHOWN WITH FULL INDEPENDENT CONTROL.
 4. FOR OPTIMAL PERFORMANCE, DATA ACCESS SHOULD NOT OCCUR DURING THE SAMPLING INSTANT. A MINIMUM TIME OF AT LEAST THE APERTURE DELAY, t_{AD} , SHOULD LAPSE PRIOR TO DATA ACCESS.

Figure 4. General Timing Diagram with BUSY/SDO2 Disabled

10942-004

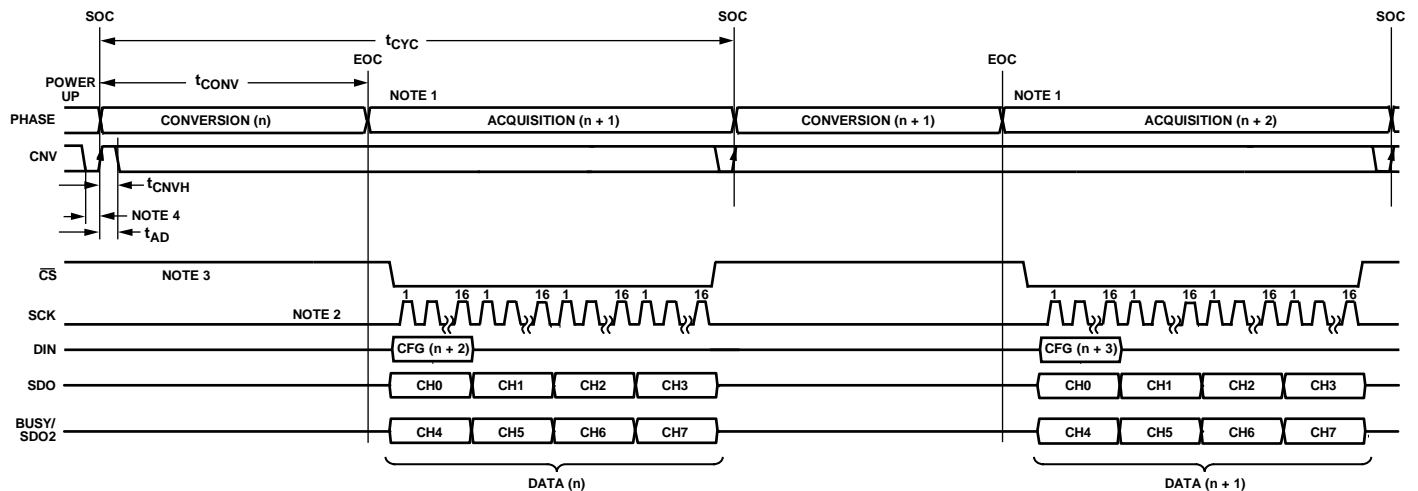

- NOTES
1. DATA ACCESS CAN ONLY OCCUR AFTER CONVERSION. BOTH CONVERSION RESULT AND THE CFG REGISTER ARE UPDATED AT THE END OF THE CONVERSION (EOC).
 2. A TOTAL OF 16 SCK FALLING EDGES ARE REQUIRED FOR CONVERSION RESULT. AN ADDITIONAL 16 EDGES AFTER THE LAST CONVERSION RESULT ON BUSY READS BACK THE CFG ASSOCIATED WITH CONVERSION.
 3. \overline{CS} CAN BE HELD LOW OR CONNECTED TO CNV. \overline{CS} IS SHOWN WITH FULL INDEPENDENT CONTROL.
 4. FOR OPTIMAL PERFORMANCE, DATA ACCESS SHOULD NOT OCCUR DURING THE SAMPLING INSTANT. A MINIMUM TIME OF AT LEAST THE APERTURE DELAY, t_{AD} , SHOULD LAPSE PRIOR TO DATA ACCESS.

Figure 5. General Timing Diagram with BUSY/SDO2 Enabled

10942-005

ABSOLUTE MAXIMUM RATINGS

Table 4.

Parameter	Rating
Analog Inputs/Outputs	
INx, COM to AGND	VSSH – 0.3 V to VDDH + 0.3 V
REFx to AGND	AGND – 0.3 V to AVDD + 0.3 V
REFIN to AGND	AGND – 0.3 V to +2.7 V
REFN to AGND	±0.3 V
Ground Voltage Differences	
AGND, RGND, DGND	±0.3 V
Supply Voltages	
VDDH to AGND	–0.3 V to +16.5 V
VSSH to AGND	+0.3 V to –16.5 V
AVDD, DVDD, VIO to AGND	–0.3 V to +7 V
ACAP, DCAP, RCAP to AGND	–0.3 V to +2.7 V
Digital Inputs/Outputs	
CNV, DIN, SCK, RESET, PD, $\overline{\text{CS}}$ to DGND	–0.3 V to VIO + 0.3 V
SDO, BUSY/SDO2 to DGND	–0.3 V to VIO + 0.3 V
Internal Power Dissipation	2 W
Junction Temperature	125°C
Storage Temperature Range	–65°C to +125°C
Thermal Impedance	
θ_{JA} (LFCSP)	44.1°C/W
θ_{JC} (LFCSP)	0.28°C/W

Stresses above those listed under Absolute Maximum Ratings may cause permanent damage to the device. This is a stress rating only; functional operation of the device at these or any other conditions above those indicated in the operational section of this specification is not implied. Exposure to absolute maximum rating conditions for extended periods may affect device reliability.

ESD CAUTION

ESD (electrostatic discharge) sensitive device. Charged devices and circuit boards can discharge without detection. Although this product features patented or proprietary protection circuitry, damage may occur on devices subjected to high energy ESD. Therefore, proper ESD precautions should be taken to avoid performance degradation or loss of functionality.

PIN CONFIGURATION AND FUNCTION DESCRIPTIONS

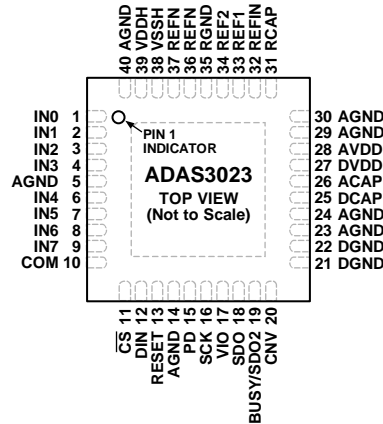

NOTES
1. CONNECT THE EXPOSED PAD TO VSSH.

10942-006

Figure 6. Pin Configuration

Table 5. Pin Function Descriptions

Pin No.	Mnemonic	Type ¹	Description
1 to 4	IN0 to IN3	AI	Input Channel 0 to Input Channel 3.
6 to 9	IN4 to IN7	AI	Input Channel 4 to Input Channel 7.
5, 14, 23, 24, 29, 30, 40	AGND	P	Analog Ground. Connect AGND to the system analog ground plane.
10	COM	AI	IN0 to IN7 Common Channel Input. Input Channel IN0 to Input Channel IN7 are referenced to a common point. The maximum voltage on this pin is ±10.24 V for all PGIA gains.
11	\overline{CS}		Chip Select. Active low signal. Enables the digital interface for writing and reading data. Use the \overline{CS} pin when sharing the serial bus. For a dedicated and simplified ADAS3023 serial interface, tie \overline{CS} to DGND or CNV.
12	DIN	DI	Data Input. DIN is the serial data input for writing the 16-bit configuration (CFG) word that is clocked into the device on the SCK rising edges. The CFG is an internal register that is updated on the rising edge of the next end of a conversion pulse, which coincides with the falling edge of BUSY/SDO2. The CFG register is written into the device on the first 16 clocks after conversion. To avoid corrupting a conversion due to digital activity on the serial bus, do not write data during a conversion.
13	RESET	DI	Asynchronous Reset. A low-to-high transition resets the ADAS3023. The current conversion, if active, is aborted and the CFG register is reset to the default state.
15	PD	DI	Power-Down. A low-to-high transition powers down the ADAS3023, minimizing the device operating current. Note that PD must be held high until the user is ready to power on the device. After powering on the device, the user must wait 100 ms until the reference is enabled and then wait for the completion of one dummy conversion before the device is ready to convert. Note that the RESET pin remains low for 100 ns after the release of PD. See the Power-Down Mode section for more information.
16	SCK	DI	Serial Clock Input. The DIN and SDO data sent to and from the ADAS3023 are synchronized with SCK.
17	VIO	P	Digital Interface Supply. Nominally, it is recommended that VIO be at the same voltage as the supply of the host interface: 1.8 V, 2.5 V, 3.3 V, or 5 V.
18	SDO	DO	Serial Data Output. The conversion result is output on this pin and synchronized to the SCK falling edges. The conversion results are presented on this pin in twos complement format.
19	BUSY/SDO2	DO	Busy/Serial Data Output 2. The converter busy signal is always output on the BUSY/SDO2 pin when \overline{CS} is logic high. If SDO2 is enabled when \overline{CS} is brought low after the EOC, the SDO outputs the data. The conversion result is output on this pin and synchronized to the SCK falling edges. The conversion results are presented on this pin in twos complement format.
20	CNV	DI	Convert Input. A conversion is initiated on the rising edge of the CNV pin.
21, 22	DGND	P	Digital Ground. Connect DGND to the system digital ground plane.
25	DCAP	P	Internal 2.5 V Digital Regulator Output. Decouple DCAP, an internally regulated output, using a 10 μF and a 0.1 μF local capacitor.
26	ACAP	P	Internal 2.5 V Analog Regulator Output. This regulator supplies power to the internal ADC core and to all of the supporting analog circuits, except for the internal reference. Decouple this internally regulated output (ACAP) using a 10 μF capacitor and a 0.1 μF local capacitor.

Pin No.	Mnemonic	Type ¹	Description
27	DVDD	P	Digital 5 V Supply. Decouple the DVDD supply to DGND using a 10 μ F capacitor and 0.1 μ F local capacitor.
28	AVDD	P	Analog 5 V Supply. Decouple the AVDD supply to AGND using a 10 μ F capacitor and 0.1 μ F local capacitor.
31	RCAP	P	Internal 2.5 V Analog Regulator Output. RCAP supplies power to the internal reference. Decouple this internally regulated output (RCAP) using a 10 μ F capacitor and a 0.1 μ F local capacitor.
32	REFIN		Internal 2.5 V Band Gap Reference Output, Reference Buffer Input, or Reference Power-Down Input. REF1 and REF2 must be tied together externally. See the Voltage Reference Input/Output section for more information.
33, 34	REF1, REF2	AI/O	Reference Input/Output. Regardless of the reference method, REF1 and REF2 need individual decoupling using external 10 μ F ceramic capacitors connected as close to REF1, REF2, and REFN as possible. See the Voltage Reference Input/Output section for more information.
35	RGND	P	Reference Supply Ground. Connect RGND to the system analog ground plane.
36, 37	REFN	P	Reference Input/Output Ground. Connect the 10 μ F capacitors that are on REF1 and REF2 to the REFN pins, then connect the REFN pins to the system analog ground plane.
38	VSSH	P	High Voltage Analog Negative Supply. Nominally, the supply of VSSH is -15 V. Decouple VSSH using a 10 μ F capacitor and a 0.1 μ F local capacitor. Connect the exposed pad to VSSH.
39	VDDH	P	High Voltage Analog Positive Supply. Nominally, the supply of VDDH is 15 V. Decouple VDDH using a 10 μ F capacitor and a 0.1 μ F local capacitor.
	EP	N/A	Exposed Pad. Connect the exposed pad to VSSH.

¹AI = analog input, AI/O = analog input/output, DI = digital input, DO = digital output, P = power, and N/A means not applicable.

TYPICAL PERFORMANCE CHARACTERISTICS

VDDH = 15 V, VSSH = -15 V, AVDD = DVDD = 5 V, VIO = 1.8 V to AVDD, unless otherwise noted.

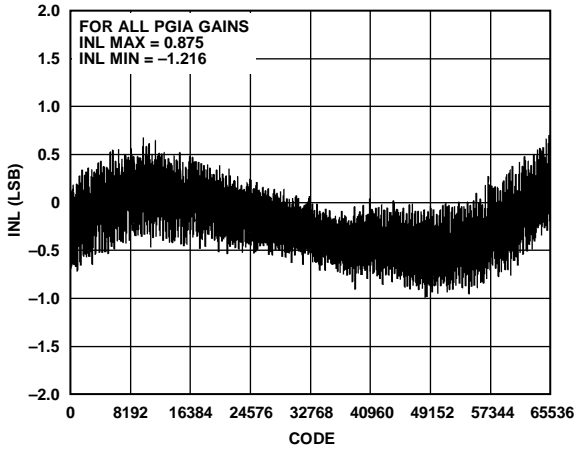

Figure 7. Integral Nonlinearity (INL) vs. Code for All PGIA Gains

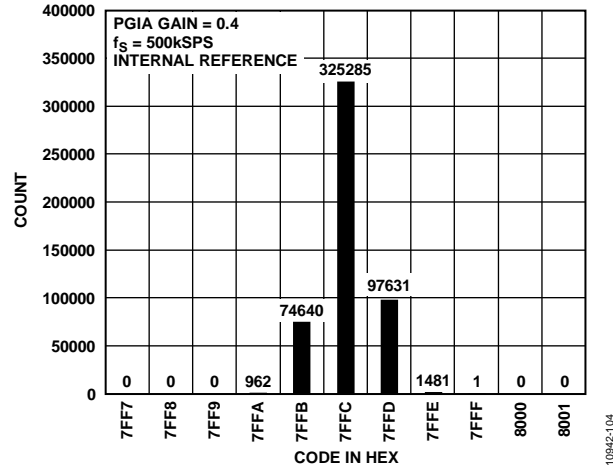

Figure 10. Histogram of a DC Input at Code Center, PGIA Gain = 0.4

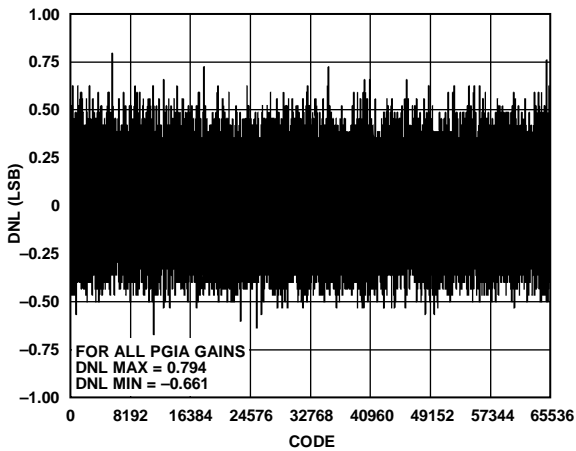

Figure 8. Differential Nonlinearity (DNL) vs. Code for All PGIA Gains

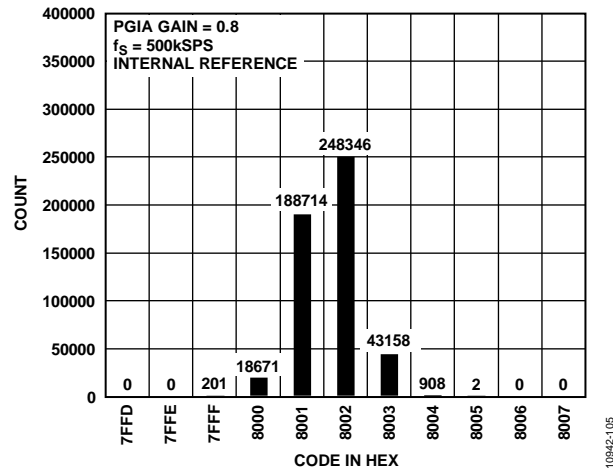

Figure 11. Histogram of a DC Input at Code Center, PGIA Gain = 0.8

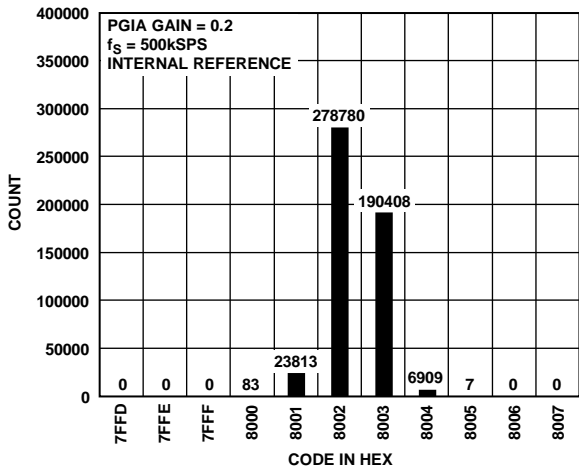

Figure 9. Histogram of a DC Input at Code Center, PGIA Gain = 0.2

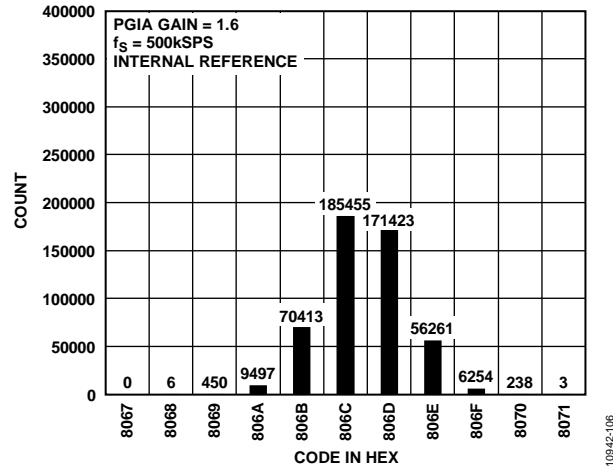

Figure 12. Histogram of a DC Input at Code Center, PGIA Gain = 1.6

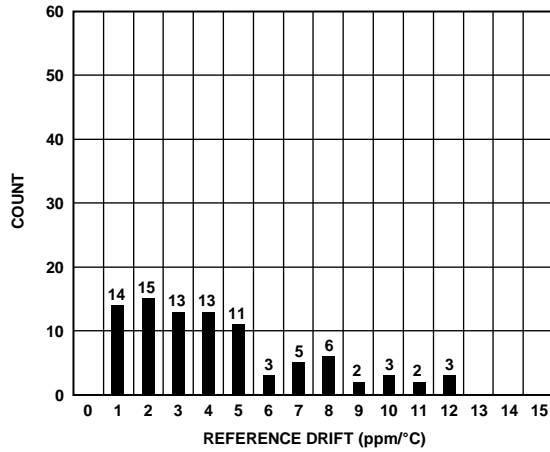

Figure 13. Reference Drift, Internal Reference

10942-116

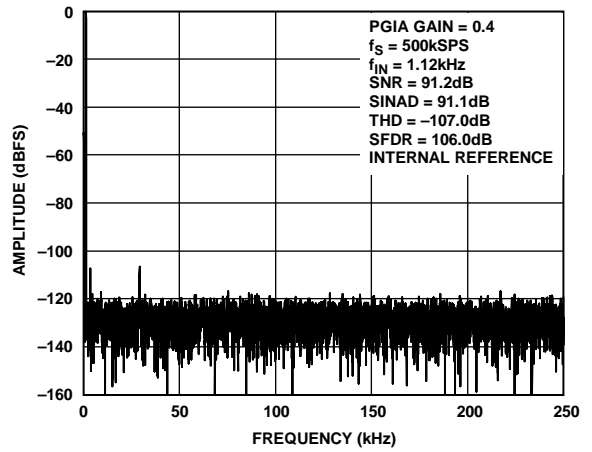

Figure 16. 1 kHz FFT, PGIA Gain = 0.4

10942-108

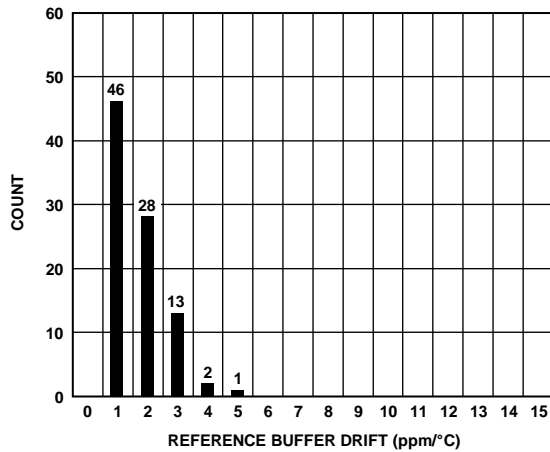

Figure 14. Reference Buffer Drift, Internal Reference

10942-117

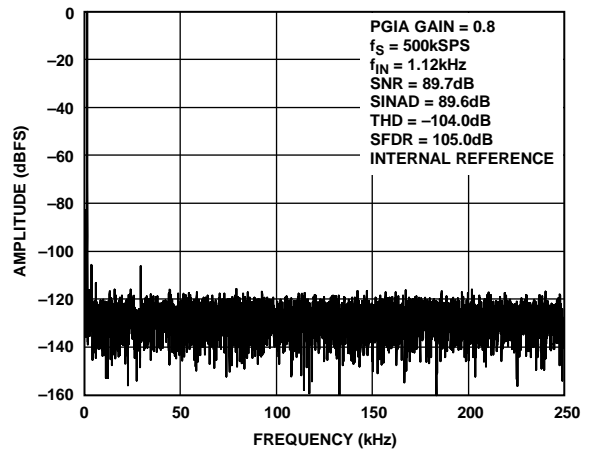

Figure 17. 1 kHz FFT, PGIA Gain = 0.8

10942-109

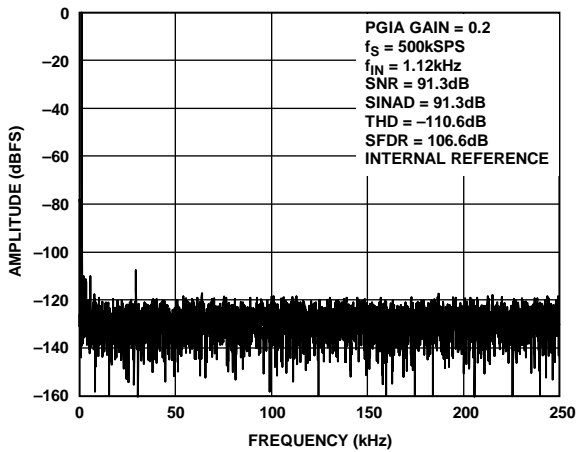

Figure 15. 1 kHz FFT, PGIA Gain = 0.2

10942-107

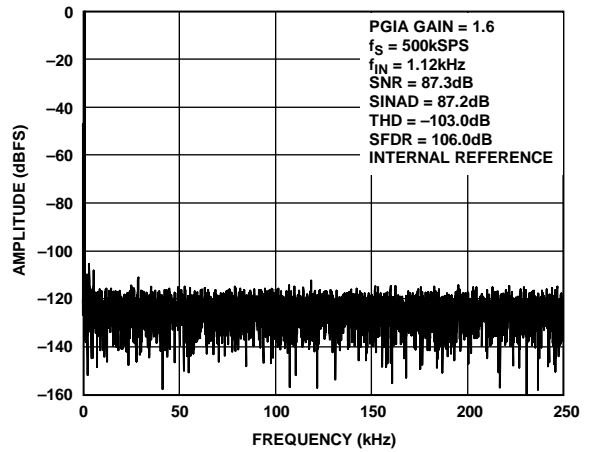

Figure 18. 1 kHz FFT, PGIA Gain = 1.6

10942-110

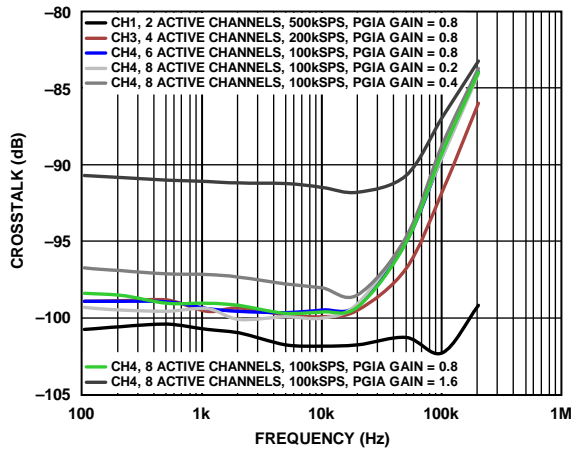

Figure 19. Crosstalk vs. Frequency

10942-113

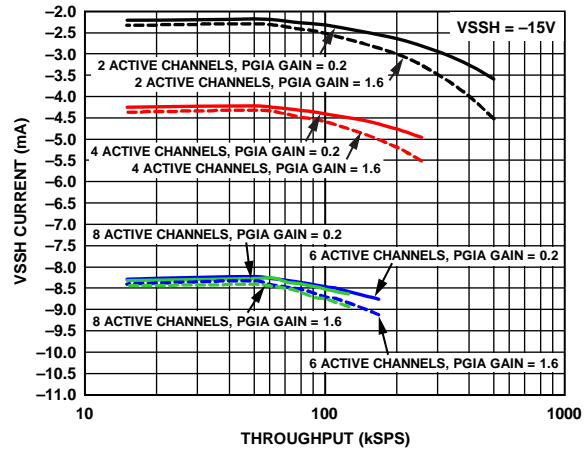

Figure 22. VSSH Current vs. Throughput

10942-118

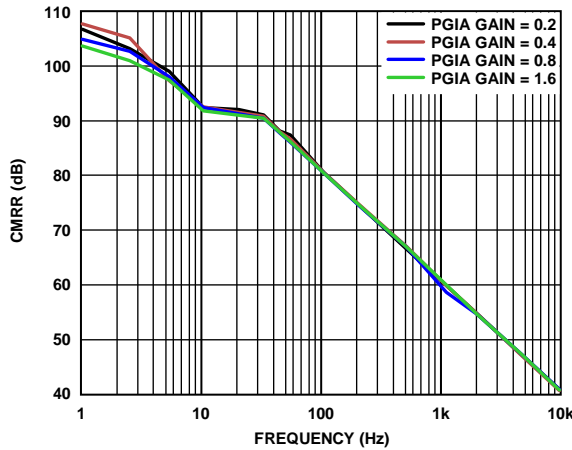

Figure 20. CMRR vs. Frequency

10942-114

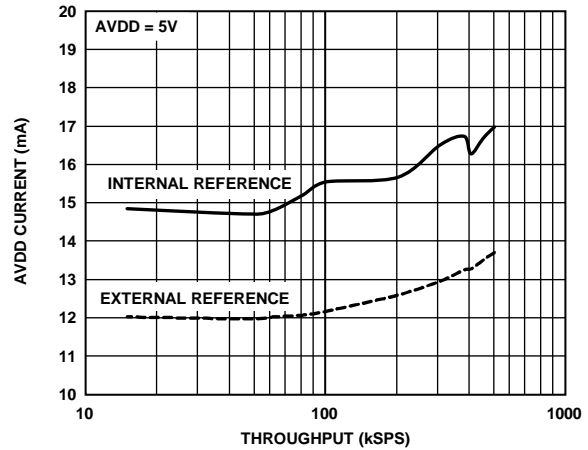

Figure 23. AVDD Current vs. Throughput

10942-119

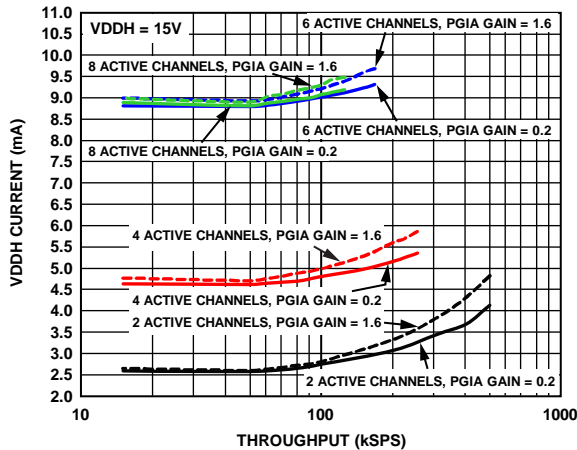

Figure 21. VDDH Current vs. Throughput

10942-115

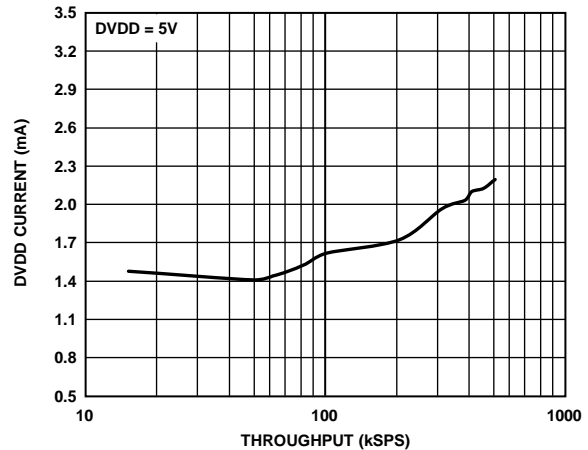

Figure 24. DVDD Current vs. Throughput

10942-120

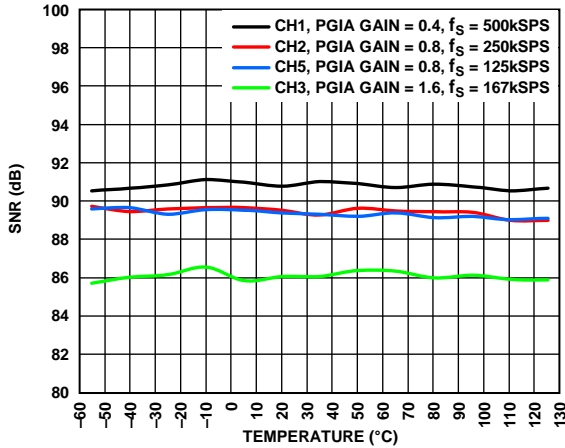

Figure 25. SNR vs. Temperature

10942-111

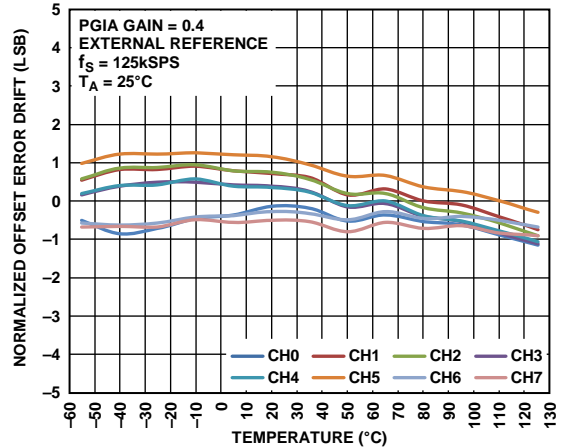

Figure 28. Normalized Offset Error Drift, PGIA Gain = 0.4

10942-122

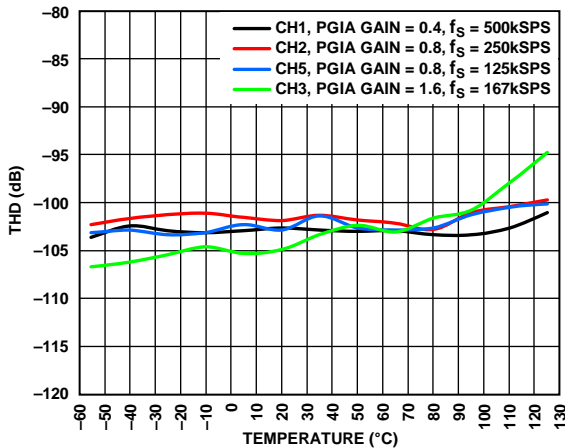

Figure 26. THD vs. Temperature

10942-112

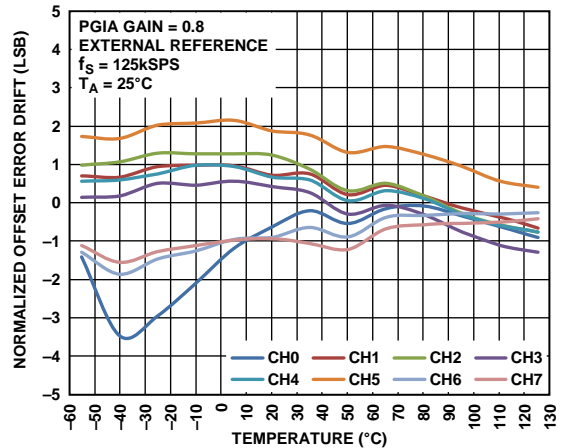

Figure 29. Normalized Offset Error Drift, PGIA Gain = 0.8

10942-123

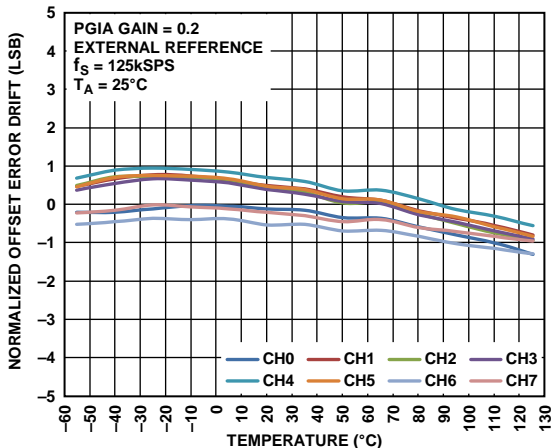

Figure 27. Normalized Offset Error Drift, PGIA Gain = 0.2

10942-121

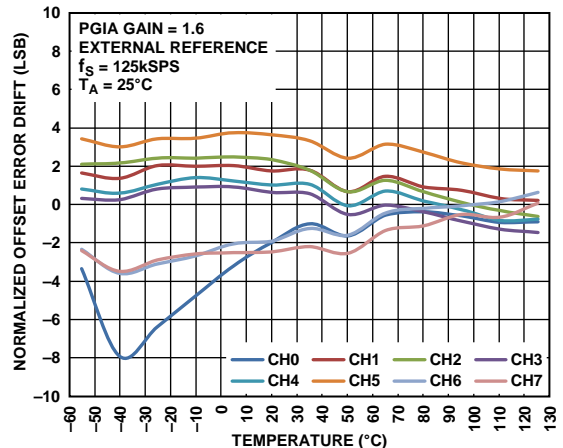

Figure 30. Normalized Offset Error Drift, PGIA Gain = 1.6

10942-124

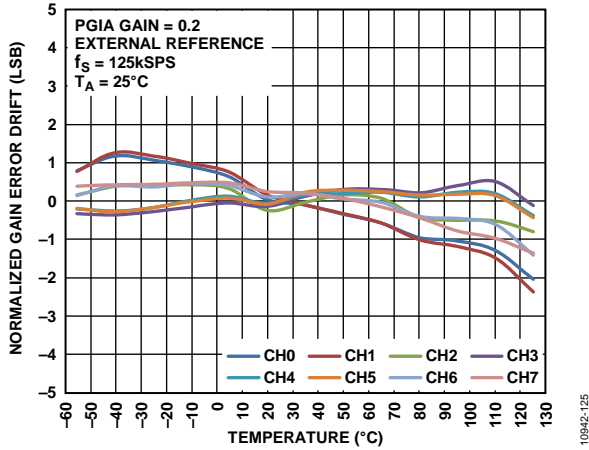

Figure 31. Normalized Gain Error Drift Error, PGIA Gain = 0.2

10942-125

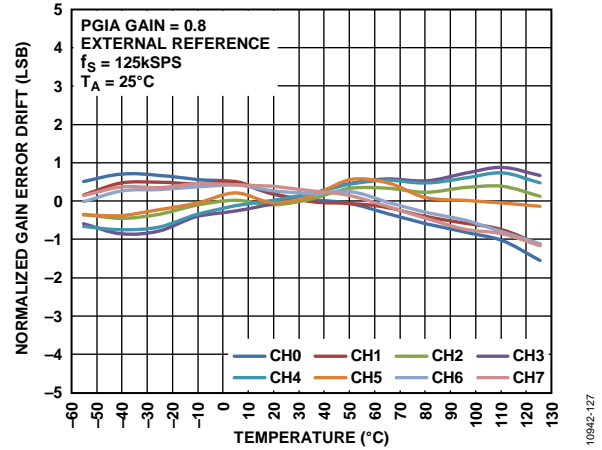

Figure 33. Normalized Gain Error Drift Error, PGIA Gain = 0.8

10942-127

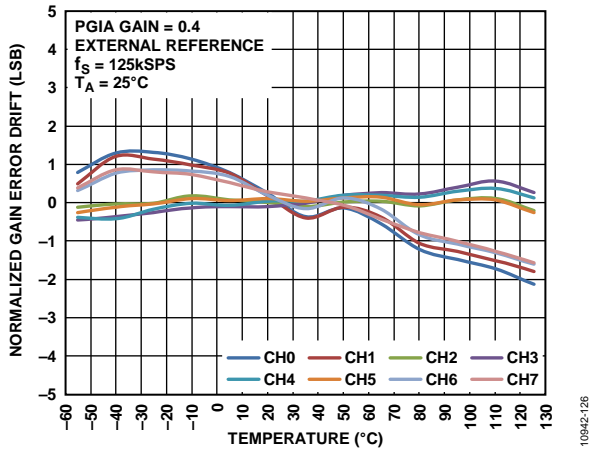

Figure 32. Normalized Gain Error Drift Error, PGIA Gain = 0.4

10942-126

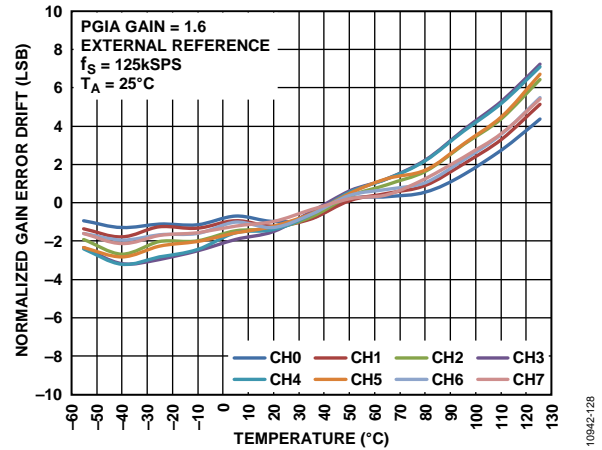

Figure 34. Normalized Gain Error Drift Error, PGIA Gain = 1.6

10942-128

TERMINOLOGY

Operating Input Voltage Range

Operating input voltage range is the maximum input voltage range, including common-mode, which can be applied to the input channels, IN0 to IN7, and COM.

Differential Input Voltage Range

Differential input voltage range is the maximum differential full-scale input range. The value changes according to the selected programmable gain setting.

Channel Off Leakage

Channel off leakage is the leakage current with the channel turned off.

Channel On Leakage

Channel on leakage is the leakage current with the channel turned on.

Common-Mode Rejection Ratio (CMRR)

CMRR is computed as the ratio of the signal magnitude of the converted result, referred to input, in the converted result to the amplitude of the common modulation signal applied to an input pair, expressed in decibels. CMRR is a measure of the ability of the ADAS3023 to reject signals, such as power line noise, that are common to the inputs. This specification is tested and specified for all input channels, IN0 to IN7, with respect to COM.

Transient Response

Transient response is a measure of the time required for the ADAS3023 to properly acquire the input after a full-scale step function is applied to the system.

Least Significant Bit (LSB)

The LSB is the smallest increment that can be represented by a converter. For a fully differential input ADC with N bits of resolution, the LSB expressed in volts is

$$LSB (V) = \frac{2V_{REF}}{2^N}$$

Integral Nonlinearity Error (INL)

INL refers to the deviation of each individual code from a line drawn from negative full scale through positive full scale. The point used as negative full scale occurs ½ LSB before the first code transition. Positive full scale is defined as a level 1½ LSB beyond the last code transition. The deviation is measured from the middle of each code to the true straight line (see Figure 37).

Differential Nonlinearity Error (DNL)

In an ideal ADC, code transitions are 1 LSB apart. DNL is the maximum deviation from this ideal value. DNL is often specified in terms of resolution for which no missing codes are guaranteed.

Offset Error

Ideally, the MSB transition occurs at an input level that is ½ LSB above analog ground. The offset error is the deviation of the actual transition from that point.

Gain Error

Ideally, the last transition (from 011 ... 10 to 011 ... 11) occurs for an analog voltage 1½ LSB below the nominal full scale. The gain error is the deviation in LSB (or percentage of full-scale range) of the actual level of the last transition from the ideal level after the offset error is removed. Closely related is the full-scale error (also in LSB or percentage of full-scale range), which includes the effects of the offset error.

Aperture Delay

Aperture delay is the measure of the acquisition performance. It is the time between the rising edge of the CNV input and the point at which the input signal is held for a conversion.

Dynamic Range

Dynamic range is the ratio of the rms value of the full scale to the total rms noise measured with a –60 dBFS input signal applied to the inputs. The value for dynamic range is expressed in decibels.

Signal-to-Noise Ratio (SNR)

SNR is the ratio of the rms value of the actual input signal to the rms sum of all other spectral components below the Nyquist frequency, excluding harmonics and dc. The value for SNR is expressed in decibels.

Signal-to-(Noise + Distortion) Ratio (SINAD)

SINAD is the ratio of the rms value of the actual input signal to the rms sum of all other spectral components below the Nyquist frequency, including harmonics but excluding dc. The value for SINAD is expressed in decibels.

Total Harmonic Distortion (THD)

THD is the ratio of the rms sum of the first five harmonic components to the rms value of a full-scale input signal expressed in decibels.

Spurious-Free Dynamic Range (SFDR)

SFDR is the difference, in decibels, between the rms amplitude of the input signal and the peak spurious signal.

Channel-to-Channel Crosstalk

Channel-to-channel crosstalk is a measure of the level of crosstalk between any channel and all other channels. The crosstalk is measured by applying a dc input to the channel under test and applying a full-scale, 10 kHz sine wave signal to all other channels. The crosstalk is the amount of signal that leaks into the test channel expressed in decibels.

Reference Voltage Temperature Coefficient

The reference voltage temperature coefficient is derived from the typical shift of output voltage at 25°C on a sample of devices at the maximum and minimum reference output voltage (V_{REF}) measured at T_{MIN} , T_A (25°C), and T_{MAX} expressed in ppm/°C.

$$TCV_{REF} \text{ (ppm/°C)} = \frac{V_{REF} (Max) - V_{REF} (Min)}{V_{REF} (25°C) \times (T_{MAX} - T_{MIN})} \times 10^6$$

where:

$V_{REF} (Max)$ is the maximum V_{REF} at T_{MIN} , T_A (25°C), or T_{MAX} .

$V_{REF} (Min)$ is the minimum V_{REF} at T_{MIN} , T_A (25°C), or T_{MAX} .

$V_{REF} (25°C) = V_{REF}$ at 25°C.

$T_{MAX} = +85°C$.

$T_{MIN} = -40°C$.

THEORY OF OPERATION

OVERVIEW

The ADAS3023 is a 16-bit, 8-channel simultaneous system on a single chip that integrates the typical components used in a data acquisition system in one easy to use, programmable device. It is capable of converting two channels simultaneously up to 500,000 samples per second (500 kSPS) throughput. The ADAS3023 features

- High impedance inputs
- High common-mode rejection
- An 8-channel, low leakage track and hold
- A programmable gain instrumentation amplifier (PGIA) with four selectable differential input ranges from ± 2.56 V to ± 20.48 V
- A 16-bit PulSAR[®] ADC with no missing codes
- An internal, precision, low drift 4.096 V reference and buffer

The ADAS3023 uses the Analog Devices patented high voltage iCMOS process allowing up to a ± 20.48 V differential input voltage range when using ± 15 V supplies, which makes the device suitable for industrial applications.

The device is housed in a small 6 mm \times 6 mm, 40-lead LFCSP package and can operate over the industrial temperature range of -40°C to $+85^{\circ}\text{C}$. A typical discrete multichannel data acquisition system containing similar circuitry requires more space on the circuit board than the ADAS3023. Therefore, advantages of the ADAS3023 solution include a reduced footprint and less complex design requirements, leading to faster time to market and lower costs.

OPERATION

The analog circuitry of the ADAS3023 consists of a high impedance, low leakage, track-and-hold PGIA with a high common-mode rejection that can accept the full-scale differential voltages of ± 2.56 V, ± 5.12 V, ± 10.24 V, and ± 20.48 V (see Figure 15). The ADAS3023 can be configured to sample two, four, six, or eight channels simultaneously.

The ADAS3023 offers true high impedance inputs in a differential structure and rejects common-mode signals present on the inputs. This architecture does not require additional input buffers (op amps) that are usually required for signal buffering, level shifting, amplification, attenuation, and kickback reduction when using switched capacitor-based SAR ADCs.

Digital control of the programmable gain setting of each channel input is set via the configuration (CFG) register.

The conversion results are output in twos complement format on the serial data output (SDO) and through an optional secondary serial data output on the BUSY/SDO2 pin. The digital interface uses a dedicated chip select ($\overline{\text{CS}}$) to control data access to and from the ADAS3023 together with a BUSY/SDO2 output, asynchronous reset (RESET), and power-down (PD) inputs.

The internal reference of the ADAS3023 uses an internal temperature compensated 2.5 V output band gap reference, followed by a precision buffer amplifier to provide the 4.096 V high precision system reference.

All of these components are configured through a serial (SPI-compatible), 16-bit CFG register. Configuration and conversion results are read after the conversions are completed.

The ADAS3023 requires a minimum of three power supplies +15 V, -15 V, and +5 V. Internal low dropout regulators provide the necessary 2.5 V system voltages that must be decoupled externally via dedicated pins (ACAP, DCAP, and RCAP). The ADAS3023 can be interfaced to any 1.8 V to 5 V digital logic family using the dedicated VIO logic level voltage supply (see Table 9).

A rising edge on the CNV pin initiates a conversion and changes the ADAS3023 from track to hold. In this state, the ADAS3023 performs the analog signal conditioning and conversion. When the signal conditioning is completed, the ADAS3023 returns to the track state while, at the same time, quantizes the sample. This two-tiered process satisfies the necessary settling time requirement and achieves a fast throughput rate of up to 500 kSPS with 16-bit accuracy.

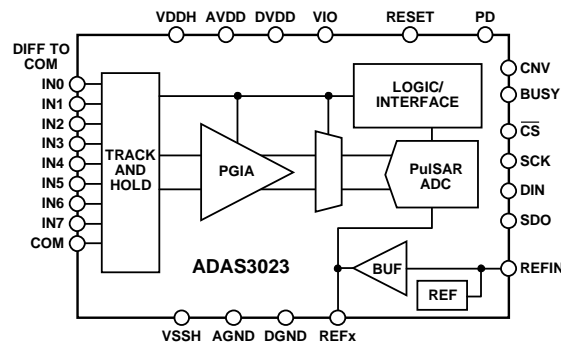

Figure 35. Simplified Block Diagram

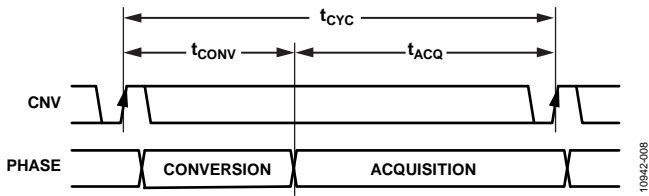

Figure 36. System Timing

Regardless of the type of signal, (single-ended symmetric or asymmetric), the ADAS3023 converts all signals present on the enabled inputs and COM pin in a differential fashion identical to an industry-standard difference or instrumentation amplifier.

The conversion results are available after the conversion is complete and can be read back at any time before the end of the next conversion. Avoid reading back data during the quiet period, indicated by BUSY/SDO2 being active high. Because the ADAS3023 has an on-board conversion clock, the serial clock (SCK) is not required for the conversion process; it is only required to present results to the user.

TRANSFER FUNCTIONS

The ideal transfer characteristic for the ADAS3023 is shown in Figure 37. The inputs are configured for differential input ranges and the data outputs are in twos complement format, as listed in Table 6.

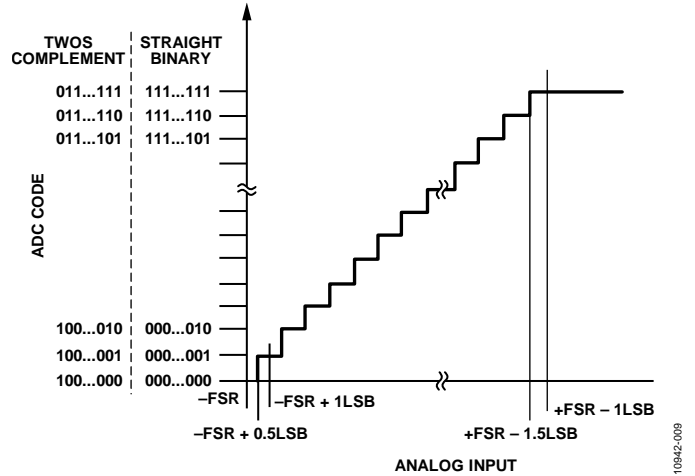

Figure 37. ADC Ideal Transfer Function

Table 6. Output Codes and Ideal Input Voltages

Description	Differential Analog Inputs, $V_{REF} = 4.096\text{ V}$	Digital Output Code (Twos Complement Hex)
FSR - 1 LSB	$(32,767 \times V_{REF}) / (32,768 \times \text{PGIA gain})$	0x7FFF
Midscale + 1 LSB	$(V_{REF} / (32,768 \times \text{PGIA gain}))$	0x0001
Midscale	0	0x0000
Midscale - 1 LSB	$-(V_{REF} / (32,768 \times \text{PGIA gain}))$	0xFFFF
-FSR + 1 LSB	$-(32,767 \times V_{REF}) / (32,768 \times \text{PGIA gain})$	0x8001
-FSR	$-V_{REF} \times \text{PGIA gain}$	0x8000

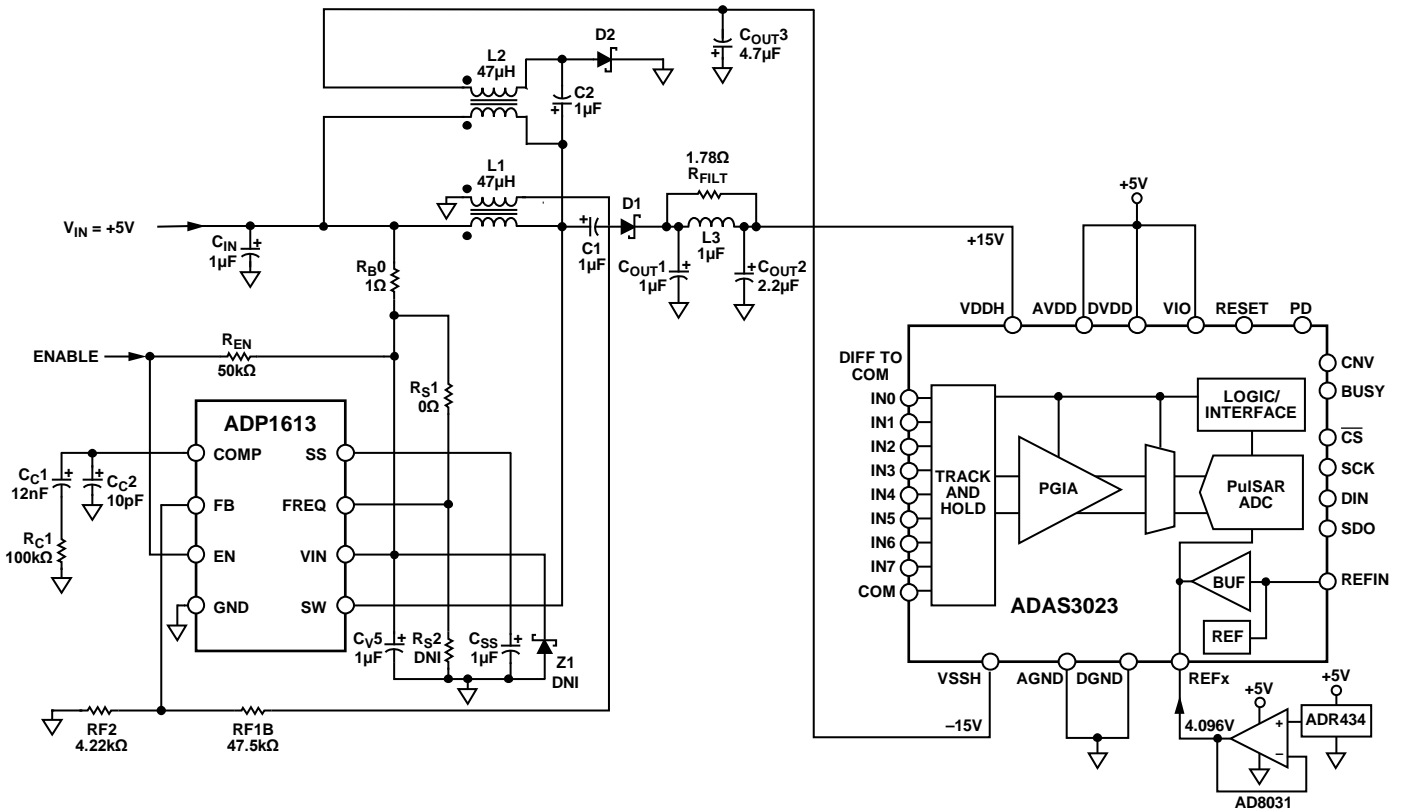

Figure 38. Complete 5 V, Single-Supply, 8-Channel Data Acquisition System with PGIA

TYPICAL APPLICATION CONNECTION DIAGRAM

As shown in Figure 38, the ADP1613 is used in an inexpensive SEPIC-Ćuk topology, which is an ideal candidate for providing the ADAS3023 with the necessary high voltage ± 15 V robust supplies (at 20 mA) and low output ripple (3 mV maximum) from an external 5 V supply. The ADP1613 satisfies the specification requirements of the ADAS3023 using minimal external components yet achieves greater than 86% efficiency. See the CN-0201 circuit note for complete information about this test setup.

ANALOG INPUTS

Input Structure

The ADAS3023 uses a differential input structure between each of the channel inputs, IN0 to IN7, and a common reference (COM), all of which sample simultaneously.

Figure 39 shows an equivalent circuit of the inputs. The diodes provide ESD protection for the analog inputs (IN0 to IN7) and COM from the high voltage supplies (VDDH and VSSH). Ensure that the analog input signal does not exceed the supply rails by more than 0.3 V because this can cause the diodes to become forward-biased and to start conducting current. The voltages beyond the absolute maximum ratings may cause permanent damage to the ADAS3023 (see Table 4).

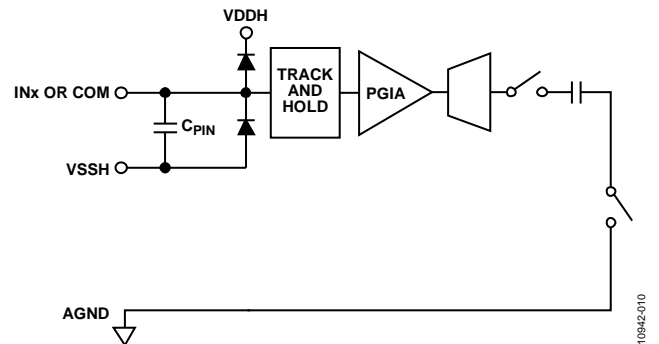

Figure 39. Equivalent Analog Input Circuit

Programmable Gain

The ADAS3023 incorporates a programmable gain instrumentation amplifier (PGIA) with four selectable ranges. The PGIA settings are specified in terms of the maximum absolute differential input voltage across an input pin and the COM pin, for example INx to COM. The power on and default conditions are preset to the ± 20.48 V (PGIA = 11) input range.

Note that because the ADAS3023 can use any input type, such as bipolar single-ended and pseudo bipolar, setting the PGIA is important to make full use of the allowable input span.

Table 7 describes each differential input range and the corresponding LSB size, PGIA bit settings, and PGIA gain.

Table 7. Differential Input Ranges, LSB Size, and PGIA Settings

Differential Input Ranges, INx – COM (V)	LSB (μV)	PGIA CFG	PGIA Gain (V/V)
±20.48	625	11	0.2
±10.24	312.5	00	0.4
±5.12	156.3	01	0.8
±2.56	78.13	10	1.6

Common-Mode Operating Range

The differential input common-mode range changes according to the input range selected for a given channel and the high voltage power supplies. Note that the operating input voltage of any input pin, as defined in the Specifications section, requires a minimum of 2.5 V of headroom from the VDDH/VSSH supplies or

$$(VSSH + 2.5 \text{ V}) \leq INx/COM \leq (VDDH - 2.5 \text{ V})$$

The following sections offer some examples of setting the PGIA for various input signals. Note that the ADAS3023 always takes the difference between the INx and COM signals.

Single-Ended Signals with a Nonzero DC Offset (Asymmetrical)

When a 5.12 V p-p signal with a 2.56 V dc offset is connected to one of the inputs (INx+) and the dc ground sense of the signal is connected to COM, the PGIA gain configuration is set to 01 for the ±5.12 V range because the maximum differential voltage across the inputs is +5.12 V. This scenario uses only half the codes available for the transfer function.

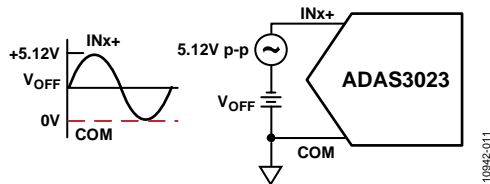

Figure 40. Typical Single-Ended Unipolar Input Using Only Half of the Codes

Single-Ended Signals with a 0 V DC Offset (Symmetrical)

Compared with the example in the Single-Ended Signals with a Nonzero DC Offset (Asymmetrical) section, a better solution for single-ended signals, when possible, is to remove as much differential dc offset between INx and COM such that the average voltage is 0 V (symmetrical around the ground sense). The differential voltage across the inputs is never greater than ±2.56 V, and the PGIA gain configuration is set for a ±2.56 V range (10). This scenario uses all of the codes available for the transfer function, making full use of the allowable differential input range.

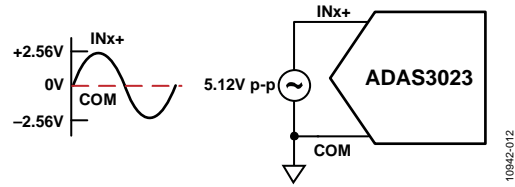

Figure 41. Optimal Single-Ended Configuration Using All Codes

Notice that the voltages in the examples are not integer values due to the 4.096 V reference and the scaling ratios of the PGIA. The maximum allowed dc offset voltage on the COM input pin for various PGIA gains in this case is shown in Table 8.

Table 8. DC Offset Voltage on COM Input and PGIA Settings¹

PGIA Gain (V/V)	DC Offset Voltage on COM (V)
0.2	0
0.4	0
0.8	±5.12
1.6	±7.68

¹ Full-scale signal on INx.

VOLTAGE REFERENCE INPUT/OUTPUT

The ADAS3023 allows the choice of an internal reference, an external reference using an internal buffer, or an external reference.

The internal reference of the ADAS3023 provides excellent performance and can be used in nearly any application. Setting the reference selection mode uses the internal reference enable bit, REFEN, and the REFIN pin as described in the following sections (Internal Reference, External Reference and Internal Buffer, External Reference, and Reference Decoupling).

Internal Reference

The precision internal reference is factory trimmed and is suitable for most applications.

Setting the REFEN bit in the CFG register to 1 (default) enables the internal reference and produces 4.096 V on the REF1 and REF2 pins; this 4.096 V output serves as the main system reference. The unbuffered 2.5 V (typical) band gap reference voltage is output on the REFIN pin, which requires an external parallel combination of 10 μF and 0.1 μF capacitors to reduce the noise on the output. Because the current output of REFIN is limited, it can be used as a source when followed by a suitable buffer, such as the AD8031. Note that excessive loading of the REFIN output lowers the 4.096 V system reference because the internal amplifier uses a fixed gain.

The internal reference output is trimmed to the targeted value of 4.096 V with an initial accuracy of ±8 mV. The reference is also temperature compensated to provide a typical drift of ±5 ppm/°C.

When the internal reference is used, decouple the ADAS3023, as shown in Figure 42. Note that both the REF1 and REF2 connections are shorted together and externally decoupled with

suitable decoupling on the REF1N output and the RCAP internally regulated supply.

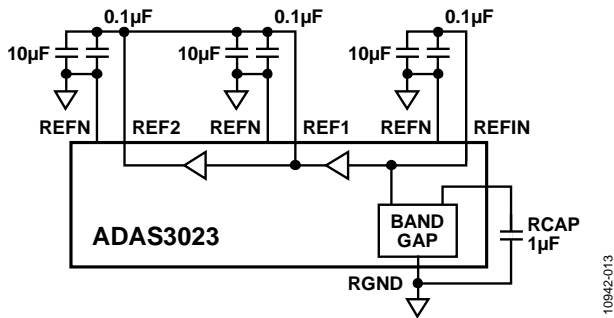

Figure 42. 4.096V Internal Reference Connection

External Reference and Internal Buffer

The external reference and internal buffer are useful where a common system reference is used or when improved drift performance is required.

Setting Bit REFEN to 0 disables the internal band gap reference, allowing the user to provide an external voltage reference (2.5 V typical) to the REF1N pin. The internal buffer remains enabled, thus reducing the need for an external buffer amplifier to generate the main system reference. Where REF1N = 2.5 V and REF1 and REF2 output 4.096 V, this serves as the main system reference.

For this configuration, connect the external source, as shown in Figure 43. Any type of 2.5 V reference can be used in this configuration (low power, low drift, small package, and so forth) because the internal buffer handles the dynamics of the ADAS3023 reference requirements.

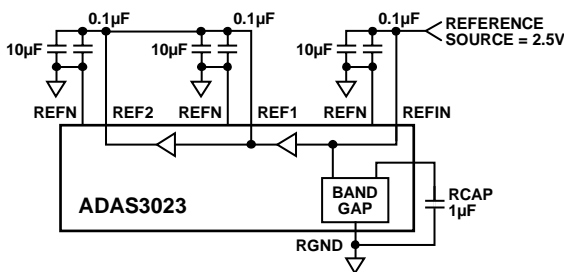

Figure 43. External Reference Using Internal Buffer

External Reference

For applications that require a precise, low drift, 4.096 V reference, an external reference can be used. Note that in this mode, disabling the internal buffer requires setting REFEN to 0, and driving or connecting REF1N to AGND; thus, both hardware and software control are necessary. Attempting to drive the REF1 and REF2 pins alone prior to disabling the internal buffer can cause source/sink contention in the outputs of the driving amplifiers.

Connect the precision 4.096 V reference directly to REF1 and REF2, which are the main system reference (see Figure 44); two recommended references are the [ADR434](#) or [ADR444](#).

If an op amp is used as an external reference source, take note of the concerns regarding driving capacitive loads. Capacitive

loading for op amps usually refers to the ability of the amplifier to remain marginally stable in ac applications but can also play a role in dc applications, such as a reference source.

Keep in mind that the reference source sees the dynamics of the bit decision process on the reference pins and further analysis beyond the scope of this data sheet may be required.

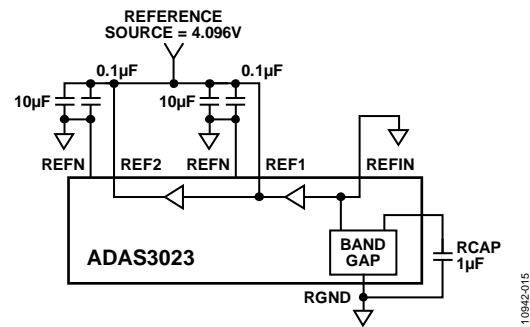

Figure 44. External Reference

Reference Decoupling

With any of the reference topologies described in the Voltage Reference Input/Output section, the REF1 and REF2 reference pins of the ADAS3023 have dynamic impedances and require sufficient decoupling, regardless of whether the pins are used as inputs or outputs. This decoupling usually consists of a low ESR capacitor connected to each REF1 and REF2 pin and to the accompanying REF1N and REF2N return paths. Ceramic chip capacitors (X5R, 1206 size) are recommended for decoupling in all of the reference topologies described in the Voltage Reference Input/Output section.

The placement of the reference decoupling capacitors plays an important role in system performance. Using thick printed circuit board (PCB) traces, mount the decoupling capacitors on the same side as the ADAS3023, close to the REF1 and REF2 pins. Route the return paths to the REF1N and REF2N inputs that, in turn, connect to the analog ground plane of the system. When it is necessary to connect to an internal PCB, minimize the resistance of the return path to ground by using as many through vias as possible.

Using the shortest distance and several vias, connect the REF1N and RGND inputs to the analog ground plane of the system, preferably adjacent to the solder pads. One common mistake is to route these traces to an individual trace that connects to the ground of the system. This can introduce noise, which may adversely affect the LSB sensitivity. To prevent such noise, use PCBs with multiple layers, including ground planes, rather than using single or double sided boards.

Smaller reference decoupling capacitor values (as low as 2.2 µF) can be used with little impact, mainly on DNL and THD. Furthermore, there is no need for an additional lower value ceramic decoupling capacitor (for example, 100 nF) that is common in decoupling schemes for high frequency noise rejection.

For applications that use multiple ADAS3023 devices or other PulSAR ADCs, using the internal reference buffer is most effective

to buffer the external reference voltage and, thereby, reduce SAR conversion crosstalk.

The voltage reference temperature coefficient (TC) directly affects the full-scale accuracy of the system; therefore, in applications where full-scale accuracy is crucial, care must be taken with the TC. For example, a ± 15 ppm/ $^{\circ}\text{C}$ TC of the reference changes the full-scale accuracy by ± 1 LSB/ $^{\circ}\text{C}$.

POWER SUPPLY

The ADAS3023 uses five supplies: AVDD, DVDD, VIO, VDDH, and VSSH (see Table 9). Note that the ACAP, DCAP, and RCAP pins are for informational purposes only because they are the outputs of the internal supply regulators.

Table 9. Supplies

Mnemonic	Function	Required
AVDD	Analog 5 V core	Yes
DVDD	Digital 5 V core	Yes, or can connect to AVDD
VIO	Digital input/output	Yes, and can connect to DVDD (for the 5 V level)
VDDH	Positive high voltage	Yes, +15 V typical
VSSH	Negative high voltage	Yes, -15 V typical
ACAP	Analog 2.5 V core	No, on chip
DCAP	Digital 2.5 V core	No, on chip
RCAP	Analog 2.5 V core	No, on chip

Core Supplies

The AVDD and DVDD pins supply the ADAS3023 analog and digital cores, respectively. Sufficient decoupling of these supplies is required, consisting of at least a 10 μF capacitor and 100 nF capacitor on each supply. Place the 100 nF capacitors as close as possible to the ADAS3023. To reduce the number of supplies that are required, supply the DVDD from the analog supply by connecting a simple RC filter between AVDD and DVDD, as shown in Figure 45.

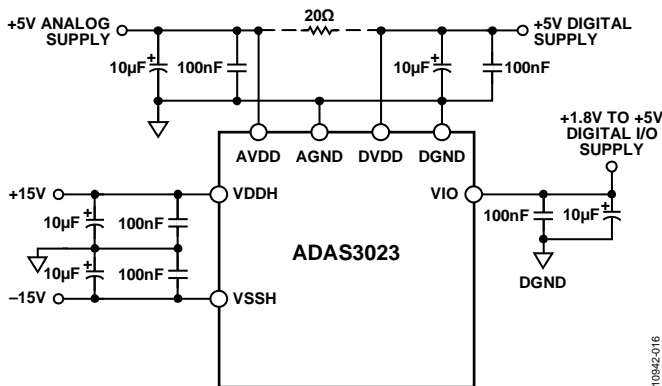

Figure 45. Supply Connections

VIO is the variable digital input/output supply and allows direct interface with any logic between 1.8 V and 5 V (DVDD supply maximum). To reduce the supplies that are required, VIO can, alternatively, be connected to DVDD when DVDD is supplied from the analog supply through an RC filter. The recommended low dropout regulators are ADP3334, ADP1715, ADP7102, and ADP7104 for the AVDD, DVDD, and VIO supplies. Note that the user must bring up the ADAS3023 power supplies in the following sequence:

1. VIO
2. VDDH
3. VSSH
4. DVDD
5. AVDD
6. REFx

High Voltage Supplies

The high voltage bipolar supplies, VDDH and VSSH, are required and must be at least 2.5 V larger than the maximum operating input voltage. Specifically, any operating input voltage (as defined in Table 2) of an input pin requires 2.5 V of headroom from the VDDH/VSSH supplies or

$$(VSSH + 2.5 \text{ V}) \leq INx/COM \leq (VDDH - 2.5 \text{ V})$$

Sufficient decoupling of these supplies is also required, consisting of at least a 10 μF capacitor and 100 nF capacitor on each supply.

POWER DISSIPATION MODES

The ADAS3023 offers two power dissipation modes: fully operational mode and power-down mode.

Fully Operational Mode

In fully operational mode, the ADAS3023 can perform the conversions normally.

Power-Down Mode

To minimize the operating currents of the device when it is idle, place the device in full power-down mode by bringing the PD input high; this places the ADAS3023 into a deep sleep mode in which CNV activity is ignored and the digital interface is inactive. Refer to the RESET and Power-Down (PD) Inputs section for timing details. In deep sleep mode, the internal regulators (ACAP, RCAP, and DCAP) and the voltage reference are powered down.

To reestablish operation, return PD to logic low. Note that, before the device can operate at the specified performance, the reference voltage must charge up the external reservoir capacitor(s) and be allowed the specified settling time. RESET must be applied after returning PD to low to restore the ADAS3023 digital core, including the CFG register, to its default state. Therefore, the desired CFG must be rewritten to the device and one dummy conversion must be completed before the device operation is restored to the configuration programmed prior to PD assertion. Note that when using the internal reference, sufficient time is required to settle it to the nominal value. For a typical connection, it requires 100 ms to settle to the nominal value (see Figure 41).

CONVERSION MODES

The ADAS3023 offers two conversion modes to accommodate varying applications, and both modes are set with the conversion mode select bit, CMS (Bit 1) of the CFG register.

Warp Mode (CMS = 0)

Setting CMS to 0 is useful where the full 2-channel throughput of 500 kSPS is required. However, in this mode, the maximum time between conversions is restricted. If this maximum period is exceeded, the conversion result can be corrupted. Therefore, the warp mode is best suited for continuously sampled applications.

Normal Mode (CMS = 1, Default)

Setting CMS to 1 is useful for all applications where the full 500 kSPS sample rate of the device is not required. In this mode, there is no maximum time restriction between conversions. This mode is the default condition from the assertion of an asynchronous reset. The main difference between the normal mode and warp mode is that the BUSY/SDO2 time, t_{CONV} , is slightly longer in normal mode than in warp mode.

DIGITAL INTERFACE

The ADAS3023 digital interface consists of asynchronous inputs and a 4-wire serial interface for conversion result readback and configuration register programming.

This interface uses the three asynchronous signals (CNV, RESET, and PD) and a 4-wire serial interface comprised of CS, SDO, SCK, and DIN. CS can also be tied to CNV for some applications.

Conversion results are presented to the serial data output pin (SDO) after the end of a conversion. The 16-bit configuration word, CFG, is programmed on the serial data input pin, DIN during the first 16 SCKs of any data transfer. This CFG register controls the settings, such as selecting the number of channels to be converted, the programmable gain settings for each channel group, and the reference choice (see Configuration Register section for more information).

CONVERSION CONTROL

The CNV input initiates conversions for N enabled channels as defined in the CFG register. The ADAS3023 is fully asynchronous and can perform conversions at any frequency from dc up to 500 kSPS, depending on the settings specified in the configuration register and the system serial clock rate.

CNV Rising—Start of Conversion (SOC)

A rising edge on the CNV changes the state of the ADAS3023 from track mode to hold mode, as well as all that is necessary to initiate a conversion. All conversion clocks are generated internally. After a conversion is initiated, the ADAS3023 ignores other activity on the CNV line (governed by the throughput rate) until the end of the conversion.

While the ADAS3023 is performing a conversion and the BUSY/SDO2 output is driven high, the ADAS3023 uses a unique 2-phase conversion process, allowing for safe data access and quiet time.

The CNV signal is decoupled from the CS pin, allowing multiple ADAS3023 devices to be controlled by the same processor. For applications where SNR is critical, the CNV source requires very low jitter, which is achieved by using a dedicated oscillator or by clocking CNV with a high frequency, low jitter clock. For applications where jitter is more tolerable or a single device is in use, tie CNV to CS. For more information on sample clock jitter and aperture delay, see the MT-007 Mini Tutorial, Aperture Time, Aperture Jitter, Aperture Delay Time—Removing the Confusion.

Although CNV is a digital signal, take care to ensure fast, clean edges with minimal overshoot, undershoot, and ringing. In addition, avoid digital activity close to the sampling instant because such activity can result in degraded SNR performance.

BUSY/SDO2 Falling Edge—End of Conversion (EOC)

The EOC is indicated by BUSY/SDO2 returning low and can be used as a host interrupt. In addition, the EOC gates data access to and from the ADAS3023. If the conversion result is not read prior to the next EOC event, the data is lost. Furthermore, if the CFG update is not completed prior to the EOC, it is discarded and

the current configuration is applied to future conversions. This pipeline ensures that the ADAS3023 has sufficient time to acquire the next sample to the specified 16-bit accuracy.

Register Pipeline

The CFG register is written on the first 16 SCKs following the EOC event, and it is updated on the next EOC event. To ensure that all CFG updates are applied during a known safe instant to the various circuit elements, the asynchronous data transfer is synchronized to the ADAS3023 timing engine using the EOC event. This synchronization introduces an inherent delay between updating the CFG register setting and the application of the configuration to a conversion. This pipeline, from the end of the current conversion (n), consists of a one-deep delay before the CFG setting takes effect. This means that two SOC and EOC events must elapse before the setting (that is, the new channel, gain, and so forth) takes effect. Note that the nomenclature (n), (n + 1), and so forth is used in the remainder of the following digital sections (Serial Data Interface, General Timing, and Configuration Register) for simplicity. Note, however, that there is no pipeline after the end of a conversion before data can be read back.

RESET AND POWER-DOWN (PD) INPUTS

The asynchronous RESET and PD inputs can be used to reset and power down the ADAS3023, respectively. Timing details are shown in Figure 46.

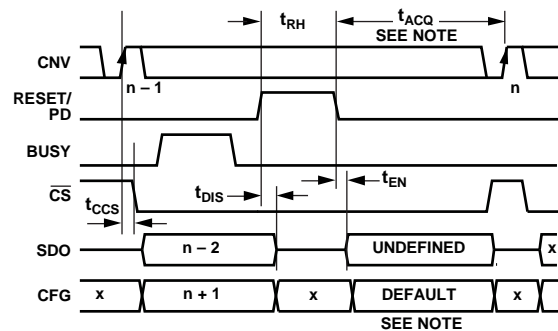

- NOTES
1. WHEN THE PART IS RELEASED FROM RESET, t_{ACQ} MUST BE MET FOR CONVERSION n IF USING THE DEFAULT CFG SETTING FOR CHANNEL IN0. WHEN THE PART IS RELEASED FROM POWER-DOWN, t_{ACQ} IS NOT REQUIRED, AND THE FIRST TWO CONVERSIONS, n AND n + 1, ARE UNDEFINED.

10942-017

Figure 46. RESET and PD Timing

A rising edge on RESET or PD aborts the conversion process and places SDO into high impedance, regardless of the CS level. Note that RESET has a minimum pulse width (active high) time for setting the ADAS3023 into the reset state. See the Configuration Register section for the default CFG setting when the ADAS3023 returns from the reset state. If this default setting is used after RESET is deasserted (Logic 0), for the conversion result to be valid, a period equal to the acquisition time (t_{ACQ}) must elapse before CNV can be asserted; otherwise, if a conversion is initiated, the result is corrupted. In addition, the output data from the previous conversion is cleared upon a reset; attempting

to access the data result prior to initiating a new conversion produces an invalid result.

Upon the device returning from power-down mode or from a reset when the default CFG is not used, there is no t_{ACQ} requirement because the first two conversions from power-up are undefined/invalid because the one-deep delay pipeline requirement must be satisfied to reconfigure the device to the desired setting.

SERIAL DATA INTERFACE

The ADAS3023 uses a simple 4-wire interface and is compatible with FPGAs, DSPs, and common serial interfaces such as a serial peripheral interface (SPI), QSPI™, and MICROWIRE®. The

interface uses the \overline{CS} , SCK, SDO, and DIN signals. Timing signals for a serial interface are shown in Figure 47.

SDO is activated when \overline{CS} is asserted. The conversion result is output on SDO and updated on the SCK falling edges. Simultaneously, the 16-bit CFG word is updated, if needed, on the serial data input (DIN). The state of BUSY/SDO2 (Bit 0) determines the output format of the MSB data when SDO is activated after the EOC. Note that, in Figure 47, SCK is shown as idling high. SCK can idle high or low, requiring the system developer to design an interface that suits setup and hold times for both SDO and DIN.

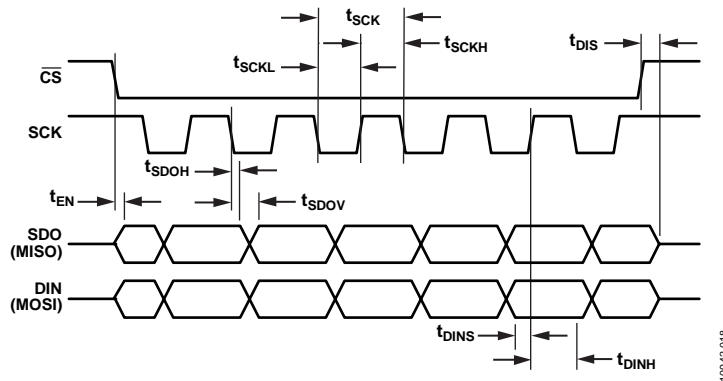

Figure 47. Serial Timing

10842-018

GENERAL TIMING

Figure 48 and Figure 49 conversion timing diagrams show the specific timing parameters, including the complete register to conversion and readback pipeline delay. These figures detail the timing from a power up or from returning from a full power down by use of the PD input. When the BUSY/SDO2 output is not enabled after the EOC, the data available on the SDO output (MSB first) can be read after the 16 SCK rising edges in sequential fashion (from Channel 0 (CH0) to Channel 7 (CH7)), as shown in Figure 48.

The converter busy signal is always output on the BUSY/SDO2 pin when \overline{CS} is logic high. When the BUSY/SDO2 output is enabled when \overline{CS} is brought low after the EOC, the SDO outputs the data of Channel 0 to Channel 3 (CH0, CH1, CH2, and CH3), and the SDO2 outputs the data of Channel 4 to Channel 7 (CH4, CH5, CH6, and CH7) after 16 SCK rising edges, as shown in Figure 49. The conversion result output on BUSY/SDO2 pin synchronizes to the SCK falling edges. The conversion results are in twos complement format. Reading or writing data during the quiet conversion phase (t_{CONV}) may cause incorrect bit decisions.

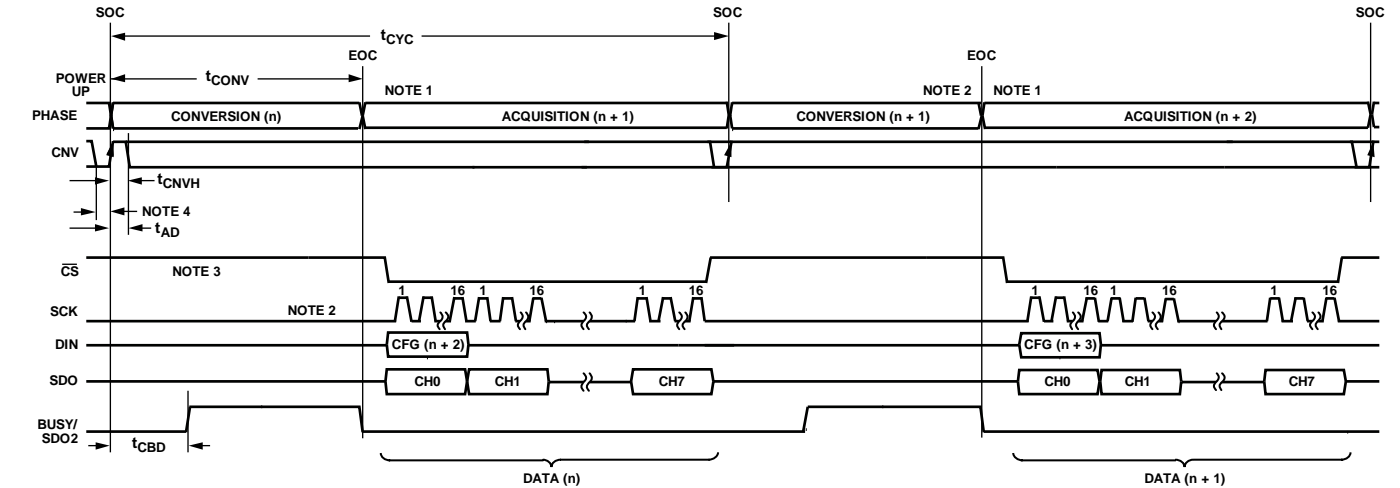

- NOTES
1. DATA ACCESS CAN ONLY OCCUR AFTER CONVERSION. BOTH CONVERSION RESULT AND THE CFG REGISTER ARE UPDATED AT THE END OF THE CONVERSION (EOC).
 2. A TOTAL OF 16 SCK FALLING EDGES ARE REQUIRED FOR CONVERSION RESULT. AN ADDITIONAL 16 EDGES AFTER THE LAST CONVERSION RESULT ON BUSY READS BACK THE CFG ASSOCIATED WITH CONVERSION.
 3. \overline{CS} CAN BE HELD LOW OR CONNECTED TO CNV. \overline{CS} IS SHOWN WITH FULL INDEPENDENT CONTROL.
 4. FOR OPTIMAL PERFORMANCE, DATA ACCESS SHOULD NOT OCCUR DURING THE SAMPLING INSTANT. A MINIMUM TIME OF AT LEAST THE APERTURE DELAY, t_{AD} , SHOULD LAPSE PRIOR TO DATA ACCESS.

Figure 48. General Timing Diagram with BUSY/SDO2 Disabled

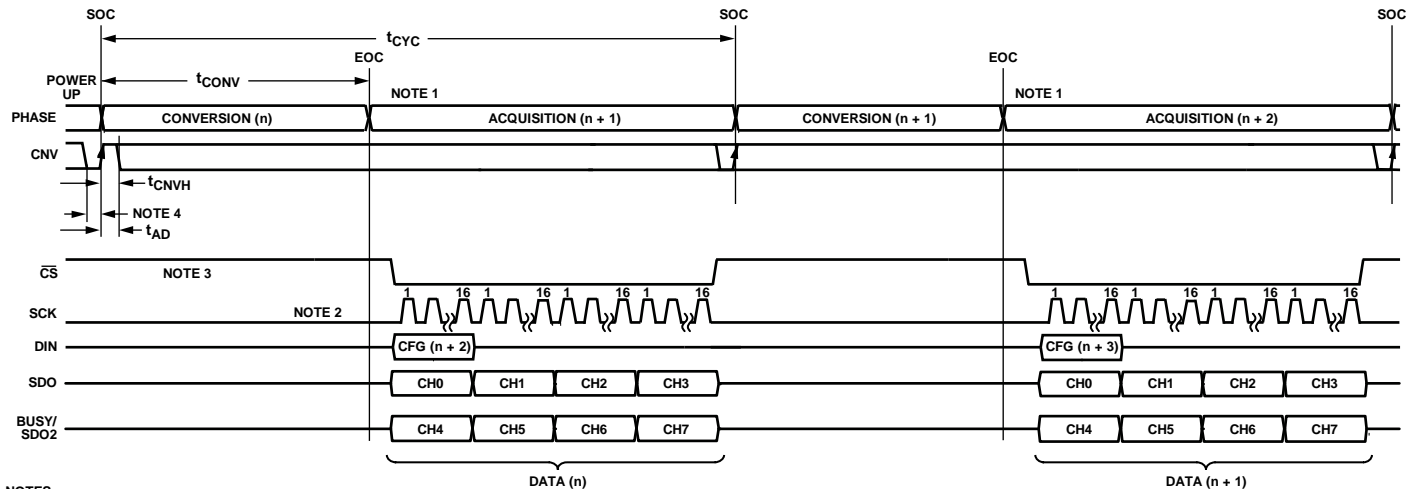

- NOTES
1. DATA ACCESS CAN ONLY OCCUR AFTER CONVERSION. BOTH CONVERSION RESULT AND THE CFG REGISTER ARE UPDATED AT THE END OF THE CONVERSION (EOC).
 2. A TOTAL OF 16 SCK FALLING EDGES ARE REQUIRED FOR CONVERSION RESULT. AN ADDITIONAL 16 EDGES AFTER THE LAST CONVERSION RESULT ON BUSY READS BACK THE CFG ASSOCIATED WITH CONVERSION.
 3. \overline{CS} CAN BE HELD LOW OR CONNECTED TO CNV. \overline{CS} IS SHOWN WITH FULL INDEPENDENT CONTROL.
 4. FOR OPTIMAL PERFORMANCE, DATA ACCESS SHOULD NOT OCCUR DURING THE SAMPLING INSTANT. A MINIMUM TIME OF AT LEAST THE APERTURE DELAY, t_{AD} , SHOULD LAPSE PRIOR TO DATA ACCESS.

Figure 49. General Timing Diagram with BUSY/SDO2 Enabled

CONFIGURATION REGISTER

The configuration register, CFG, is a 16-bit programmable register for selecting all of the user-programmable options of the ADAS3023 (see Table 11).

The register is loaded when data is read back for the first 16 SCK rising edges, and it is updated at the next EOC. Note that there is always a one-deep delay when writing to CFG, and when reading back from CFG, it is the setting associated with the current conversion.

The default CFG setting is applied when the ADAS3023 returns from the reset state (RESET = high) to the operational state (RESET = low). Returning from the full power-down state (PD = high) to an enabled state (PD = low), the default CFG setting is not applied and at least one dummy conversion is

required for the user specified CFG to take effect. To ensure the digital core is in the default state, apply an external reset after the deassertion of PD. The default value is $CFG[15:0] = 0xFFFF$. To read back the contents of the configuration register, CFG, an additional 16 SCKs are provided after all of the channel data have been read, and CFG is made available on the SDO output. The default CFG settings configure the ADAS3023 as follows:

- Overwrites contents of the CFG register.
- Selects the eight input channels mode.
- Configures the PGIA gain to 0.20 (± 20.48 V).
- Enables the internal reference.
- Selects normal conversion mode.
- Disables the SDO2 readout mode.

Table 10. Configuration Register, CFG Bit Map; Default Value = 0xFFFF (1111 1111 1111 1111)

15	14	13	12	11	10	9	8	7	6	5	4	3	2	1	0
CFG	INx	INx	RSV	PGIA	PGIA	PGIA	PGIA	PGIA	PGIA	PGIA	PGIA	RSV	REFEN	CMS	BUSY/SDO2

Table 11. Configuration Register Description

Bit No.	Bit Name	Description															
15	CFG	Configuration update. 0 = keeps current configuration settings. 1 = overwrites contents of register.															
[14:13]	INx	Selection of the number of channels to be converted simultaneously.															
		<table border="1"> <thead> <tr> <th>Bit 14</th><th>Bit 13</th><th>Channels</th></tr> </thead> <tbody> <tr> <td>0</td><td>0</td><td>2</td></tr> <tr> <td>0</td><td>1</td><td>4</td></tr> <tr> <td>1</td><td>0</td><td>6</td></tr> <tr> <td>1</td><td>1</td><td>8</td></tr> </tbody> </table>	Bit 14	Bit 13	Channels	0	0	2	0	1	4	1	0	6	1	1	8
Bit 14	Bit 13	Channels															
0	0	2															
0	1	4															
1	0	6															
1	1	8															
12	RSV	Reserved. Setting or clearing this bit has no effect.															
[11:4]	PGIA	Programmable gain selection (see the Programmable Gain section).															
		<table border="1"> <thead> <tr> <th>Bit (Odd)</th><th>Bit (Even)</th><th>PGIA Gain</th></tr> </thead> <tbody> <tr> <td>0</td><td>0</td><td>± 10.24 V</td></tr> <tr> <td>0</td><td>1</td><td>± 5.12 V</td></tr> <tr> <td>1</td><td>0</td><td>± 2.56 V</td></tr> <tr> <td>1</td><td>1</td><td>± 20.48 V (default)</td></tr> </tbody> </table>	Bit (Odd)	Bit (Even)	PGIA Gain	0	0	± 10.24 V	0	1	± 5.12 V	1	0	± 2.56 V	1	1	± 20.48 V (default)
Bit (Odd)	Bit (Even)	PGIA Gain															
0	0	± 10.24 V															
0	1	± 5.12 V															
1	0	± 2.56 V															
1	1	± 20.48 V (default)															
[11:10]	PGIA	Sets the gain of IN0.															
[9:8]	PGIA	Sets the gain of IN1.															
[7:6]	PGIA	Sets the gain of IN3 to IN2.															
[5:4]	PGIA	Sets the gain of IN4 to IN7.															
3	RSV	Reserved. Setting or clearing this bit has no effect.															
2	REFEN	Internal reference (see the Pin Configuration and Function Descriptions and Voltage Reference Input/Output sections). 0 = disables the internal reference. Disable the internal reference buffer by pulling REFEN to ground. 1 = enables the internal reference (default).															
1	CMS	Conversion mode selection (see the Conversion Modes section). 0 = uses the warp mode for conversions with a time between conversion restriction. 1 = uses the normal mode for conversions (default).															
0	BUSY/SDO2	Secondary data output control using the BUSY/SDO2 pin. 0 = enables the device busy status when the \overline{CS} pin is held high. On the \overline{CS} falling edge, the MSB of Channel 1 is presented on the BUSY/SDO2 input and subsequent data is presented on the SCK falling edges. 1 = enables the device busy status only (default). All data is transmitted via the SDO pin on the SCK falling edge.															

PACKAGING AND ORDERING INFORMATION

OUTLINE DIMENSIONS

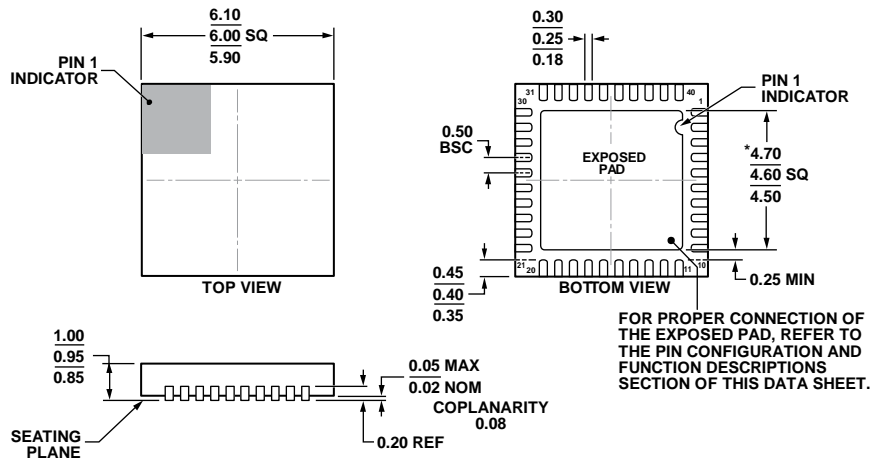

*COMPLIANT TO JEDEC STANDARDS MO-220-VJJD-5 WITH EXCEPTION TO EXPOSED PAD DIMENSION.

Figure 50. 40-Lead Lead Frame Chip Scale Package [LFCSP_VQ]
6 mm × 6 mm Body, Very Thin Quad
(CP-40-15)
Dimensions shown in millimeters

07-19-2012-B

ORDERING GUIDE

Model ¹	Temperature Range	Package Description	Package Option
ADAS3023BCPZ	-40°C to +85°C	40-Lead Lead Frame Chip Scale Package [LFCSP_VQ]	CP-40-15
ADAS3023BCPZ-RL7	-40°C to +85°C	40-Lead Lead Frame Chip Scale Package [LFCSP_VQ]	CP-40-15
EVAL-ADAS3023EDZ	-40°C to +85°C	Evaluation Board	

¹ Z = RoHS Compliant Part.

NOTES

NOTES