



# Low Distortion, Precision, Wide Bandwidth Op Amp

## AD9618\*

### FEATURES

Usable Closed-Loop Gain Range:  $+5/-1$  to  $\pm 100$   
Low Distortion:  $-63$  dBc (2nd) at 20 MHz  
Small Signal Bandwidth: 160 MHz ( $A_V = +10$ )  
Large Signal Bandwidth: 150 MHz at 5 V p-p  
Settling Time: 10 ns to 0.1%; 14 ns to 0.02%  
Overdrive and Output Short Circuit Protected  
Fast Overdrive Recovery  
DC Nonlinearity 5 ppm

### APPLICATIONS

Driving Flash Converters  
D/A Current to Voltage Converters  
IF, Radar Processors  
Baseband and Video Communications  
Photodiode, CCD Preamps

### GENERAL DESCRIPTION

The AD9618 is a current feedback amplifier which utilizes a proprietary architecture to produce superior distortion and dc precision. It achieves this along with fast settling, very fast slew rate, wide bandwidth (both small signal and large signal), and exceptional signal fidelity. The device achieves  $-63$  dBc 2nd harmonic distortion at 20 MHz while maintaining 160 MHz small signal and 150 MHz large signal bandwidths.

These attributes position the AD9618 as an ideal choice for driving flash ADCs and buffering the latest generation of DACs. Optimized for applications requiring gain between  $+5/-1$  to  $\pm 40$ , the AD9618 is unity gain stable without external compensation.

Additional benefits of the AD9618B and T grades include input offset voltage of 500  $\mu$ V and temperature coefficient (TC) of 3  $\mu$ V/ $^{\circ}$ C. These accuracy performance levels make the AD9618 an excellent choice for driving emerging high resolution (12–16 bits), high speed analog to digital converters and flash converters.

The AD9618 offers outstanding performance in high fidelity, wide bandwidth applications in instrumentation ranging from network and spectrum analyzers to oscilloscopes, and in military systems such as radar, SIGINT, and ESM systems. The superior slew rate, low overshoot, and fast settling of the AD9618 allow the device to be used in pulse applications such as communications receivers and high speed ATE. Most monolithic op amps suffer in these precision pulse applications due to slew rate limiting.

\*Patent pending.

### REV. A

Information furnished by Analog Devices is believed to be accurate and reliable. However, no responsibility is assumed by Analog Devices for its use, nor for any infringements of patents or other rights of third parties which may result from its use. No license is granted by implication or otherwise under any patent or patent rights of Analog Devices.

### PIN CONFIGURATION

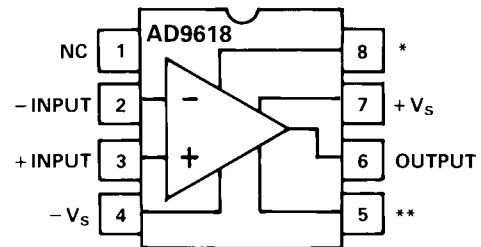

\*OPTIONAL  $+V_S$     \*\*OPTIONAL  $-V_S$

NOTE: FOR BEST SETTTLING TIME AND DISTORTION PERFORMANCE, USE OPTIONAL SUPPLY CONNECTIONS. PERFORMANCE INDICATED IN SPECIFICATIONS IS BASED ON SUPPLY CONNECTIONS TO THESE PINS.

The AD9618J operates over the range of 0 to  $+70^{\circ}$ C and is available in either an 8-pin plastic mini-DIP or an 8 lead plastic small outline package (SOIC). The AD9618A and B versions are rated over the industrial temperature range of  $-40^{\circ}$ C to  $+85^{\circ}$ C. The AD9618S and T versions are rated over the military temperature range of  $-55^{\circ}$ C to  $+125^{\circ}$ C; and are available processed to MIL-STD-883B.

One Technology Way, P.O. Box 9106, Norwood, MA 02062-9106  
Tel: 617/329-4700    Fax: 617/326-8703    Twx: 710/394-6577  
West Coast    Central    Atlantic  
714/641-9391    214/231-5094    215/643-7790

# AD9618—SPECIFICATIONS

## ABSOLUTE MAXIMUM RATINGS<sup>1</sup>

Supply Voltages ( $\pm V_S$ )	$\pm 7$ V
Common Mode Input Voltage	$\pm V_S$
Differential Input Voltage	3 V
Continuous Output Current <sup>2</sup>	70 mA
Operating Temperature Ranges	
AD9618JN/JR	0 to +70°C
AD9618AQ/BQ	-40°C to +85°C
AD9618SQ/TQ	-55°C to +125°C

## Storage Temperature

AD9618JN/JR	-65°C to +125°C
AD9618AQ/BQ/SQ/TQ	-65°C to +150°C

## Junction Temperature<sup>3</sup>

AD9618JN/JR	150°C
AD9618AQ/BQ/SQ/TQ	175°C

Lead Soldering Temperature (10 Seconds) +300°C

## DC ELECTRICAL CHARACTERISTICS

(unless otherwise noted,  $A_V = +10$ ;  $\pm V_S = \pm 5$  V;  $R_F = 1000 \Omega$ ;  $R_{LOAD} = 100 \Omega$ )

Parameter	Conditions	Temp	Test Level	AD9618JN/JR			AD9618AQ/SQ			AD9618BQ/TQ			Units
				Min	Typ	Max	Min	Typ	Max	Min	Typ	Max	
Input Offset Voltage <sup>4, 5</sup>		+25°C	I	-1.1	+0.5	+2.2	-1.1	+0.5	+2.2	0.0	+0.5	+1.1	mV
Input Offset Voltage TC <sup>5</sup>		Full	IV	-4	+3	+25	-4	+3	+25	-4	+3	+25	$\mu$ V/°C
Input Bias Current <sup>5</sup>													
Inverting		+25°C	I	-45	0	+45	-45	0	+45	-20	0	+20	$\mu$ A
Noninverting		+25°C	I	-25	+5	+35	-25	+5	+35	-13	+5	+18	$\mu$ A
Input Bias Current TC <sup>5</sup>													
Noninverting		Full	IV	-50	+30	+125	-50	+30	+125	-50	+30	+125	nA/°C
Inverting		Full	IV	-50	+40	+130	-50	+40	+130	-50	+40	+130	nA/°C
Input Resistance													
Noninverting		+25°C	V		75			75			75		k $\Omega$
Input Capacitance													
Noninverting		+25°C	V		1.5			1.5			1.5		pF
Common Mode Input Range <sup>6</sup>	$T = T_{max}$	←	II	$\pm 1.0$	$\pm 1.2$		$\pm 1.0$	$\pm 1.2$		$\pm 1.0$	$\pm 1.2$		V
	$T = T_{min}$ to +25°C	←	II	$\pm 1.4$	$\pm 1.5$		$\pm 1.4$	$\pm 1.5$		$\pm 1.4$	$\pm 1.5$		V
Common Mode Rejection Ratio <sup>7</sup>	$T = T_{max}$	←	II	44	48		44	48		44	48		dB
	$T = +25^\circ\text{C}$	←	II	48	52		48	52		48	52		dB
	$T = T_{min}$	←	II	50	54		50	54		50	54		dB
	$\Delta V_S = \pm 5\%$	Full	II	50	60		50	60		50	60		dB
Power Supply Rejection Ratio													
Open Loop Gain													
$T_O$	At dc	+25°C	V		3			3			3		M $\Omega$
Nonlinearity	At dc	+25°C	V		5			5			5		ppm
Output Voltage Range		+25°C	II	$\pm 3.3$	$\pm 3.7$		$\pm 3.3$	$\pm 3.7$		$\pm 3.3$	$\pm 3.7$		V
Output Impedance	At dc	+25°C	V		0.08			0.08			0.08		$\Omega$
Output Current (50 $\Omega$ Load)	$T = +25^\circ\text{C}$ to $T_{max}$	←	II	60			60			60			mA
	$T = T_{min}$	←	II	50			50			50			mA

## AC ELECTRICAL CHARACTERISTICS

(unless otherwise noted,  $A_V = +10$ ;  $\pm V_S = \pm 5$  V;  $R_F = 1 \text{ k}\Omega$ ;  $R_{LOAD} = 100 \Omega$ )

Parameter	Conditions	Temp	Test Level	AD9618JN/JR			AD9618AQ/SQ			AD9618BQ/TQ			Units
				Min	Typ	Max	Min	Typ	Max	Min	Typ	Max	
FREQUENCY DOMAIN													
Bandwidth (-3 dB)													
Small Signal	$V_{OUT} \leq 2$ V p-p	Full	II	130	160		130	160		130	160	MHz	
Large Signal	$V_{OUT} \leq 5$ V p-p	Full	IV		150		120	150		120	150	MHz	
Bandwidth Variation vs. $A_V$	$A_V = -1$ to $\pm 40$	+25°C	V		35			35			35	MHz	
Amplitude of Peaking (<50 MHz)	$T = T_{min}$ to +25°C	←	II		0			0	0.4		0	0.4	dB
	$T = T_{max}$	←	II		0			0	0.7		0	0.7	dB
Amplitude of Peaking (>50 MHz)	$T = T_{min}$ to +25°C	←	II		0			0	0.6		0	0.6	dB
	$T = T_{max}$	←	II		0			0	1.2		0	1.2	dB
Amplitude of Roll-Off (<75 MHz)		Full	II		0.5			0.5	1.2		0.5	1.2	dB
Phase Nonlinearity	dc to 75 MHz	+25°C	V		0.5			0.5			0.5		Degree
2nd Harmonic Distortion	2 V p-p; 4.3 MHz	Full	IV		-83	-75		-83	-75		-83	-75	dBc
	2 V p-p; 20 MHz	Full	IV		-63	-55		-63	-55		-63	-55	dBc
	2 V p-p; 60 MHz	Full	II		-51	-43		-51	-43		-51	-43	dBc
3rd Harmonic Distortion	2 V p-p; 4.3 MHz	Full	IV		-85	-77		-85	-77		-85	-77	dBc
	2 V p-p; 20 MHz	Full	IV		-70	-62		-70	-62		-70	-62	dBc
	2 V p-p; 60 MHz	Full	II		-62	-54		-62	-54		-62	-54	dBc
Input Noise Voltage	10 MHz	+25°C	V		1.2			1.2			1.2		nV/ $\sqrt{\text{Hz}}$
Inverting Input Noise Current	10 MHz	+25°C	V		24			24			24		pA/ $\sqrt{\text{Hz}}$

Parameter	Conditions	Temp	Test Level	AD9618JN/JR			AD9618AQ/SQ			AD9618BQ/TQ			Units
				Min	Typ	Max	Min	Typ	Max	Min	Typ	Max	
Average Equivalent Integrated Input Noise Voltage	0.1 to 200 MHz	+25°C	V	38			38			38			μV, rms
<b>TIME DOMAIN</b>													
Slew Rate	V <sub>OUT</sub> = 4 V Step	Full	IV	1800			1400 1800			1400 1800			V/μs
Rise/Fall Time V <sub>OUT</sub> = 2 V Step V <sub>OUT</sub> = 5 V Step	T = +25°C to T = T <sub>min</sub>	Full	IV	2.2			2.2 2.6			2.2 2.6			ns
		←	IV	2.3			2.3 2.8			2.3 2.8			ns
		←	IV	2.3			2.3 3.1			2.3 3.1			ns
Overshoot	V <sub>OUT</sub> = 2 V Step	Full	IV	2			2 10			2 10			%
Settling Time To 0.1% To 0.02% To 0.1% To 0.02%	V <sub>OUT</sub> = 2 V Step V <sub>OUT</sub> = 2 V Step V <sub>OUT</sub> = 4 V Step V <sub>OUT</sub> = 4 V Step	Full	IV	9			9 15			9 15			ns
		Full	IV	14			14 23			14 23			ns
		Full	IV	10			10 16			10 16			ns
		Full	IV	16			16 24			16 24			ns
		Full	IV	16			16 24			16 24			ns
2×Overdrive Recovery to ±2 mV of Final Value	V <sub>IN</sub> = 0.6 V Step	+25°C	V	50			50			50			ns
Propagation Delay		+25°C	V	2			2			2			ns
Differential Gain <sup>8</sup>		Full	V	0.01			0.01			0.01			%
Differential Phase <sup>8</sup>		Full	V	0.02			0.02			0.02			Degree
<b>POWER SUPPLY REQUIREMENTS</b>													
Quiescent Current													
	+I <sub>S</sub>	Full	II	31 43			31 43			31 43			mA
-I <sub>S</sub>	Full	II	31 43			31 43			31 43			mA	

## NOTES

<sup>1</sup>Absolute maximum ratings are limiting values to be applied individually and beyond which the serviceability of the circuit may be impaired. Functional operability is not necessarily implied. Exposure to absolute maximum rating conditions for an extended period of time may affect device reliability.

<sup>2</sup>Output is short circuit protected to ground, but not to supplies. Continuous short circuit to ground may affect device reliability.

<sup>3</sup>Typical thermal impedances (part soldered onto board):

Mini-DIP: θ<sub>JA</sub> = 140°C/W; θ<sub>JC</sub> = 30°C/W.

Side Brazed/Cerdip: θ<sub>JA</sub> = 110°C/W; θ<sub>JC</sub> = 20°C/W.

SOIC Package: θ<sub>JA</sub> = 150°C/W; θ<sub>JC</sub> = 30°C/W.

<sup>4</sup>Measured with respect to the inverting input.

<sup>5</sup>Typical is defined as the mean of the distribution.

<sup>6</sup>Measured in voltage follower configuration.

<sup>7</sup>Measured with V<sub>IN</sub> = ±0.25 V.

<sup>8</sup>Frequency = 4.3 MHz; R<sub>L</sub> = 150 Ω; A<sub>V</sub> = +10.

Specifications subject to change without notice.

## EXPLANATION OF TEST LEVELS

Test Level

I - 100% production tested.

II - 100% production tested at +25°C and sample tested at specified temperatures. AC testing of J grade devices done on sample basis.

III - Sample tested only.

IV - Parameter is guaranteed by design and characterization testing.

V - Parameter is a typical value only.

VI - All devices are 100% production tested at +25°C. 100% production tested at temperature extremes for extended temperature devices; sample tested at temperature extremes for commercial/industrial devices.

## ORDERING GUIDE

Model	Temperature Range	Package Description	Package Option
AD9618JN	0 to +70°C	Plastic DIP	N-8
AD9618JR	0 to +70°C	SOIC	R-8
AD9618AQ	-40°C to +85°C	Cerdip	Q-8
AD9618BQ	-40°C to +85°C	Cerdip	Q-8
AD9618SQ	-55°C to +125°C	Cerdip	Q-8
AD9618TQ	-55°C to +125°C	Cerdip	Q-8

## DIE CONNECTIONS

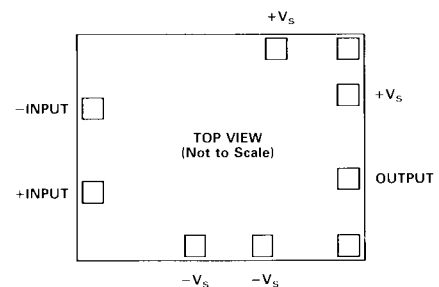

DIE SIZE = 53 × 67 × 15 mils

# AD9618

## THEORY OF OPERATION

The AD9618 has been designed to combine the key attributes of traditional “low frequency” precision amplifiers with exceptional high frequency characteristics that are independent of closed-loop gain. Previous “high frequency” closed-loop amplifiers have low open loop gain relative to precision amplifiers. This results in relatively poor dc nonlinearity and precision, as well as excessive high frequency distortion due to open loop gain roll-off.

Operational amplifiers use two basic types of feedback correction, each with advantages and disadvantages. Voltage feedback topologies exhibit an essentially constant gain bandwidth product. This forces the closed-loop bandwidth to vary inversely with closed-loop gain. Moreover, this type design typically slew rate limits in a way that causes the large signal bandwidth to be much lower than its small signal characteristics.

A newer approach is to use current feedback to realize better dynamic performance. This architecture provides two key attributes over voltage feedback configurations: (1) avoids slew rate limiting and therefore large signal bandwidth can approach small signal performance; and (2) low bandwidth variation versus gain settings, due to the inherently low open loop inverting input resistance ( $R_S$ ).

The AD9618 uses a new current feedback topology that overcomes these limitations and combines the positive attributes of both current feedback and voltage feedback designs. These devices achieve excellent high frequency dynamics (slew, BW and distortion) along with excellent low frequency linearity and good dc precision.

## DC GAIN CHARACTERISTICS

A simplified equivalent schematic is shown below. When operating the device in the inverting mode, the input signal error current ( $I_E$ ) is amplified by the open loop transimpedance gain ( $T_O$ ). The output signal generated is equal to  $T_O \times I_E$ . Negative feedback is applied through  $R_F$  such that the device operates at a gain ( $G$ ) equal to  $-R_F/R_I$ .

Noninverting operation is similar, with the input signal applied to the high impedance buffer (noninverting) input. As before,

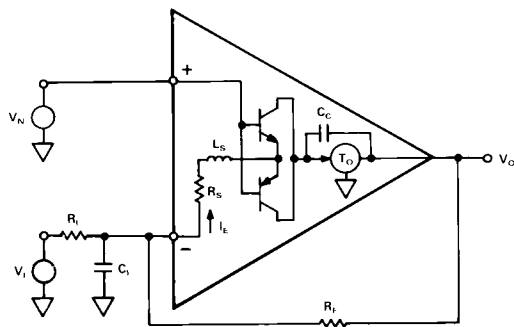

Equivalent Circuit

an output (buffer) error current ( $I_E$ ) is generated at the low impedance inverting input. The signal generated at the output is fed back to the inverting input such that the external gain is  $(1 + R_F/R_I)$ . The feedback mechanics are identical to the voltage feedback topology when exact equations are used.

The major difference lies in the front end architecture. A voltage feedback amplifier has symmetrical high resistance (buffered) inputs. A current feedback amplifier has a high noninverting

resistance (buffered) input and a low inverting (buffer output) input resistance. The feedback mechanics can be easily developed using current feedback and transresistance open loop gain  $T(s)$  to describe the I/O relationship. (See typical specification chart.)

DC closed-loop gain for the AD9618 can be calculated using the following equations:

$$G = \frac{V_O}{V_I} \approx \frac{-R_F/R_I}{1 + 1/LG} \quad \text{inverting} \quad (1)$$

$$G = \frac{V_O}{V_N} \approx \frac{1 + R_F/R_I}{1 + 1/LG} \quad \text{noninverting} \quad (2)$$

$$\text{where: } \frac{1}{LG} \approx \frac{R_S(R_F + R_S||R_I)}{T(s)(R_S||R_I)} \quad (3)$$

Because the noninverting input buffer is not ideal, input resistance  $R_S$  (at dc) is gain dependent and is typically higher for noninverting operation than for inverting operation.  $R_S$  will approach the same value ( $\approx 9 \Omega$ ) for both at input frequencies above 50 MHz. Below the open loop corner frequency, the non-inverting  $R_S$  can be approximated as:

$$R_S (\text{noninverting}) \approx 9 + \frac{T(s)}{A_O} = 9 + \frac{T_O}{A_O} \Big|_{dc} \quad (4)$$

where:  $A_O = \text{Open Loop Voltage Gain} \approx G \times 350$

Inverting  $R_S$  below the open loop corner frequency can be approximated as:

$$R_S (\text{inverting}) \approx 9 + \frac{T(s)}{A_O} = 9 + \frac{T_O}{A_O} \Big|_{dc} \quad (5)$$

where:  $A_O = 140,000$

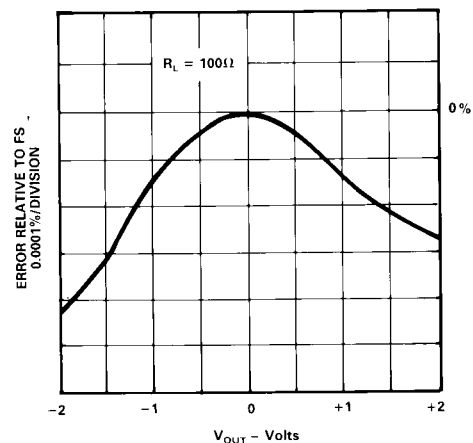

DC Nonlinearity vs.  $V_{OUT}$

The AD9618 approaches this condition. With  $T_O = 3 \times 10^6 \Omega$  and  $R_S = 32 \Omega$  (dc), a gain error of 0.04% typically results for  $G = -1$  and 0.11% for  $G = -100$ . Moreover, the architecture linearizes the open loop gain over its operating voltage range and temperature resulting in  $>16$  bits of linearity.

**AC GAIN CHARACTERISTICS**

Closed-loop bandwidth at high frequencies is determined primarily by the roll-off of T(s). But circuit layout is critical to minimize external parasitics which can degrade performance by causing premature peaking and/or reduced bandwidth.

The inverting and noninverting dynamic characteristics are similar. When driving the noninverting input, the inverting input capacitance (C<sub>I</sub>) will cause the noninverting closed-loop bandwidth to be higher than the inverting bandwidth for gains less than five (5). In the remaining cases, inverting and noninverting responses are nearly identical.

For best overall dynamic performance, the value of the feedback resistor (R<sub>F</sub>) should be 1000 Ω. Although bandwidth reduces as closed-loop gain increases, the change is relatively small due to low equivalent series input impedance, Z<sub>S</sub>. (See typical performance charts.) The simplified equations governing the device's dynamic performance are shown below.

Closed-Loop Gain vs. Frequency:  
(noninverting operation)

$$\frac{V_O}{V_S} \approx \frac{1 + \frac{R_F}{R_I}}{s\tau \left(1 + \frac{R_S}{R_I}\right) + 1} \tag{6}$$

where:  $\tau = R_F \times C_C = 1.0 \text{ ns}$  ( $R_F = 1 \text{ k}\Omega$ )

$$\text{Slew Rate} \approx \frac{\Delta V_O}{R_F K C_C} \times e^{-\tau/R_F K C_C} \tag{7}$$

where:  $K = 1 + \frac{R_S}{R_I}$

**Increasing Bandwidth at Low Gains**

By reducing R<sub>F</sub>, wider bandwidth and faster pulse response can be attained beyond the specified values, although increased overshoot, settling time, and possible ac peaking may result. As a rule of thumb, overshoot and bandwidth will increase by 1% and 8%, respectively, for a 5% reduction in R<sub>F</sub> at gains of ±10.

Equations 6 and 7 are simplified and do not accurately model the second order (open loop) frequency response term which is the primary contributor to overshoot, peaking, and nonlinear bandwidth expansion. (See Open Loop Bode Plots.) The user should exercise caution when selecting R<sub>F</sub> values much lower than 1000 Ω. Note that a feedback resistor must be used in all situations.

**Increasing Bandwidth at High Gains**

Closed-loop bandwidth can be extended at high closed-loop gain by reducing R<sub>F</sub>. Bandwidth reduction is a result of the feedback current being split between R<sub>S</sub> and R<sub>I</sub>. As the gain increases (for a given R<sub>F</sub>), more feedback current is shunted through R<sub>I</sub>, which reduces closed-loop bandwidth (see Equation 6). To maintain specified BW, the following equations can be used to approximate R<sub>F</sub> and R<sub>I</sub> for any gain from = +5/-1 to ±40.

$$R_F = 1100 \pm 8 G \tag{8}$$

(+ for inverting and - for noninverting)

$$R_I \approx \frac{1100 - 10 G}{G - 1} \tag{9}$$

(noninverting)

$$R_I \approx \frac{1100 + 10 G}{G} \tag{10}$$

(inverting)

G = Closed-Loop Gain.

**Bandwidth Reduction**

The closed-loop bandwidth can be reduced by increasing R<sub>F</sub>. Equations 6 and 7 can be used to determine the closed-loop bandwidth for any value R<sub>F</sub>. Do not connect a feedback capacitor across R<sub>F</sub>, as this will degrade dynamic performance and possibly induce oscillation.

**DC Precision and Noise**

Output offset voltage results from both input bias currents and input offset voltage. These input errors are multiplied by the noise gain term (1 + R<sub>F</sub>/R<sub>I</sub>) and algebraically summed at the output as shown below.

$$V_O = V_{IO} \times \left(1 + \frac{R_F}{R_I}\right) \pm IB_n \times R_N \times \left(1 + \frac{R_F}{R_I}\right) \pm IB_i \times R_F \tag{11}$$

Since the inputs are asymmetrical, IB<sub>i</sub> and IB<sub>n</sub> do not correlate. Canceling their output effects by making R<sub>N</sub> = R<sub>F</sub>||R<sub>I</sub> will not reduce output offset errors, as it would for voltage feedback am-

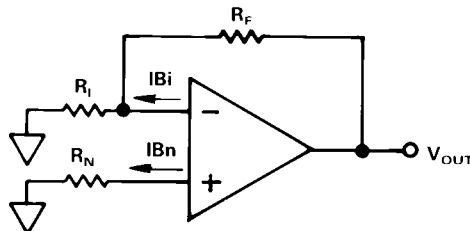

Output Offset Voltage

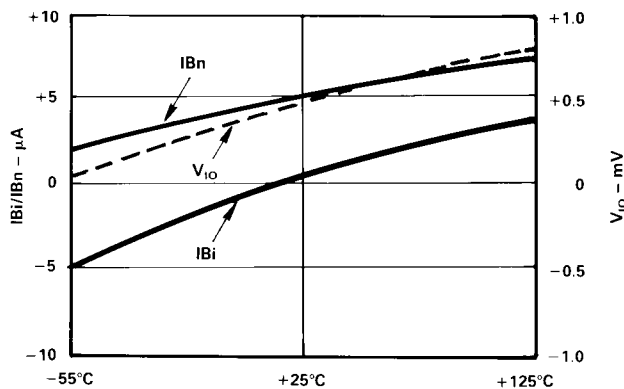

DC Accuracy

plifiers. Typically, IB<sub>n</sub> is 5 μA and V<sub>IO</sub> is +0.5 mV (1 sigma = 0.3 mV), which means that the dc output error can be reduced by making R<sub>N</sub> ≈ 100 Ω. Note that the offset drift will not change significantly because the IB<sub>n</sub> TC is relatively small. (See specification table.)

# AD9618

The effective noise at the output of the amplifier can be determined by taking the root sum of the squares of Equation 11 and applying the spectral noise values found in the typical graph section. This applies to noise from the op amp only. Note that both the noise figure and equivalent input offset voltage improve as the closed-loop gain is increased (by keeping  $R_F$  fixed and reducing  $R_I$  with  $R_N = 0 \Omega$ ).

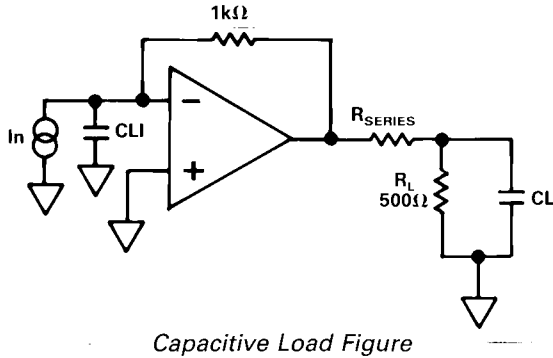

## Capacitive Load Considerations

Due to the low inverting input resistance ( $R_S$ ) and output buffer design, the AD9618 can directly handle input and/or output load capacitances of up to 10 pF. See the chart below.

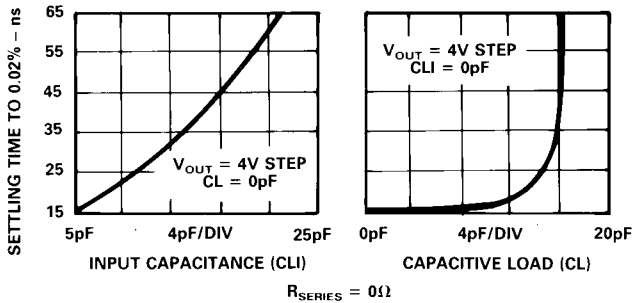

A small series resistor can be used at the output of the amplifier and outside of the feedback loop to facilitate driving larger capacitive loads or for obtaining faster settling time. For capacitive loads above 10 pF,  $R_{SERIES}$  should be considered.

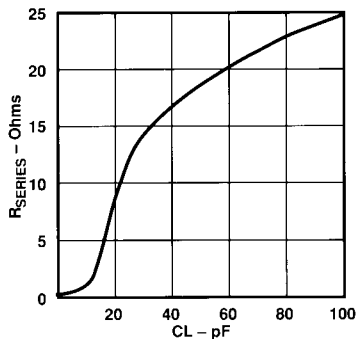

*Recommended  $R_{SERIES}$  vs. CL*

## APPLYING THE AD9618

The superior frequency and time domain specifications of the AD9618 make it an obvious choice for driving flash converters and buffering the outputs of high speed DACs. Its outstanding distortion and noise performance make it well suited as a driver for analog-to-digital converters (ADCs) with resolutions as high as 16 bits.

Typical circuits for inverting and noninverting applications are shown in Figures 1 and 2.

Closed-loop gain for noninverting configurations is determined by the value of  $R_I$  according to the equation:

$$G = 1 + \frac{R_F}{R_I} \quad (12)$$

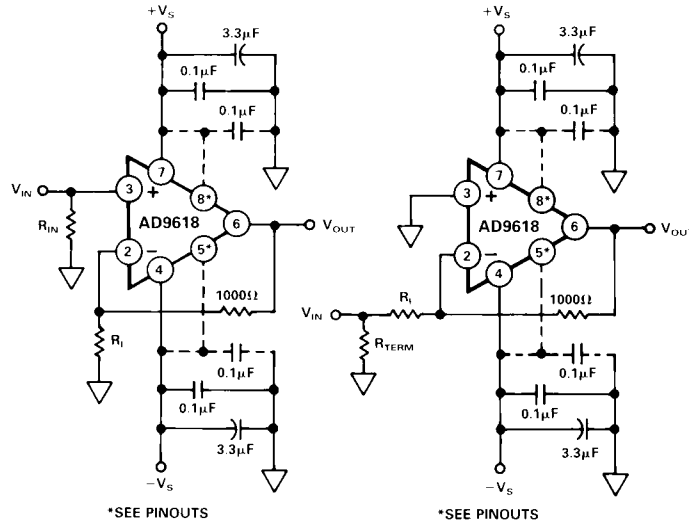

*Figure 1. Noninverting Operation*

*Figure 2. Inverting Operation*

To preserve the amplifier's full bandwidth, the noninverting input should be driven from a low impedance source.

A recommended circuit for an inverting amplification is shown in Figure 2.

Closed-loop gain for inverting configurations is determined by the value of  $R_I$  per the following equation:

$$G = -\frac{R_F}{R_I} \quad (13)$$

## LAYOUT CONSIDERATIONS

As with all high performance amplifiers, printed circuit layout is critical in obtaining optimum results with the AD9618. The ground plane in the area of the amplifier should cover as much of the component side of the board as possible. Each power supply trace should be decoupled close to the package with at least a 3.3 μF tantalum and a low inductance, 0.1 μF ceramic capacitor.

All lead lengths for input, output, and the feedback resistor should be kept as short as possible. All gain setting resistors should be chosen for low values of parasitic capacitance and inductance, i.e., microwave resistors and/or carbon resistors.

Stripline techniques should be used for lead lengths in excess of one inch. Sockets should be avoided if possible because of their stray inductance and capacitance. If sockets are necessary, individual pin sockets such as AMP p/n 6-330808-3 should be used. These contribute far less stray reactance than molded socket assemblies.

An evaluation board is available from Analog Devices for a nominal charge.

**Typical Performance** ( $A_v = +10$ ;  $\pm V_S = \pm 5V$ ;  $R_F = 1\text{ k}\Omega$ , unless otherwise noted)

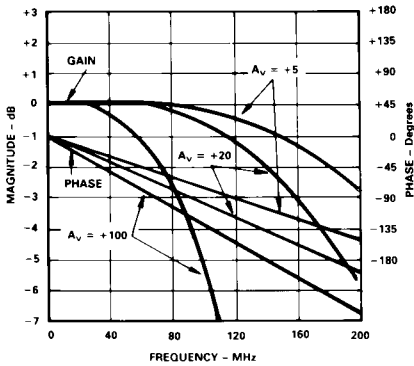

Noninverting Frequency Response

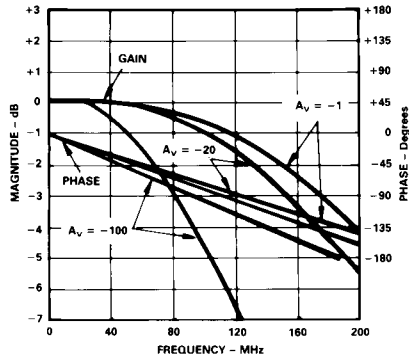

Inverting Frequency Response

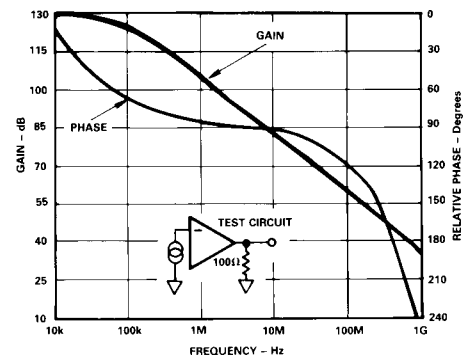

Open Loop Transimpedance Gain [T(s) Relative to 1 Ω]

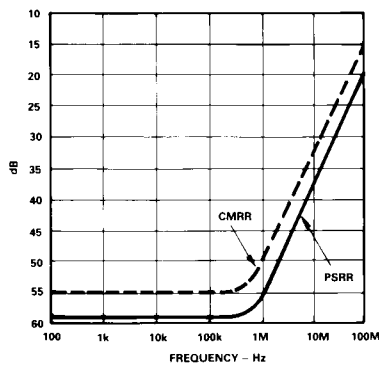

CMRR and PSRR

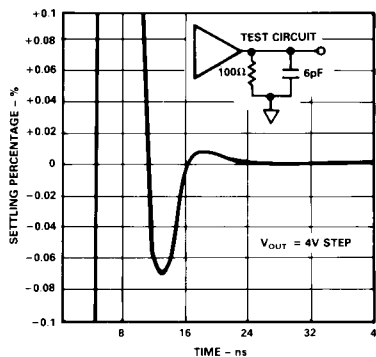

Settling Time

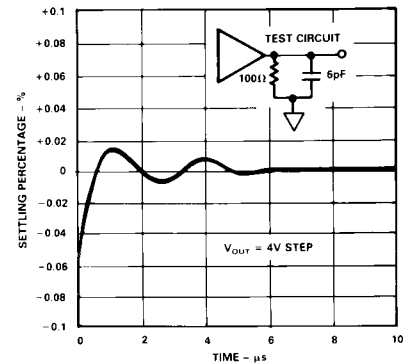

Long Term Settling Time

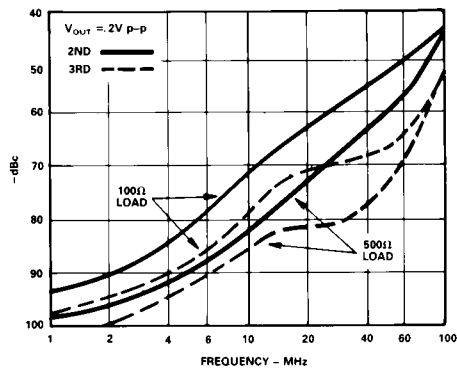

Harmonic Distortion

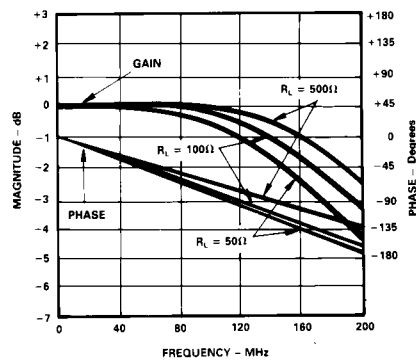

Frequency Response vs.  $R_{LOAD}$

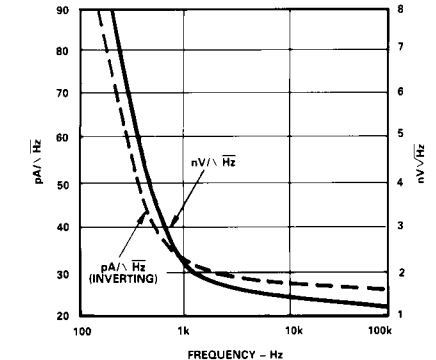

Equivalent Input Noise

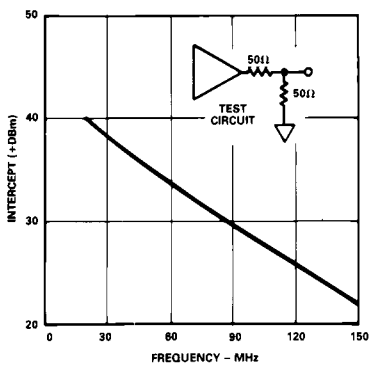

Intermodulation Distortion (IMD)

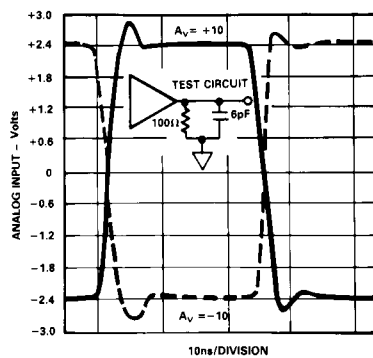

Large Signal Pulse Response

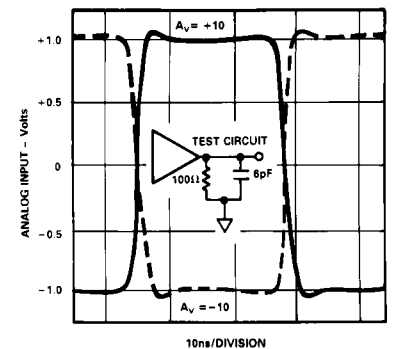

Small Signal Pulse Response

# OUTLINE DIMENSIONS

Dimensions shown in inches and (mm).

## Suffix JR

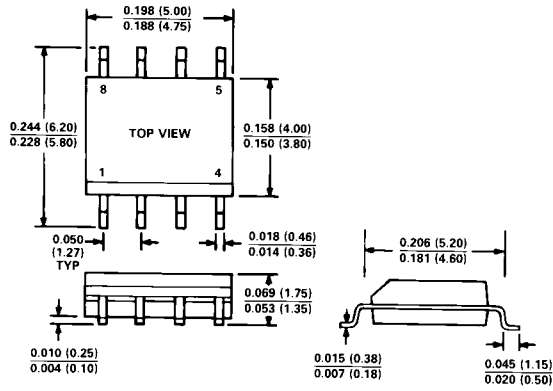

## Suffixes AQ/BQ/SQ/TQ/883B

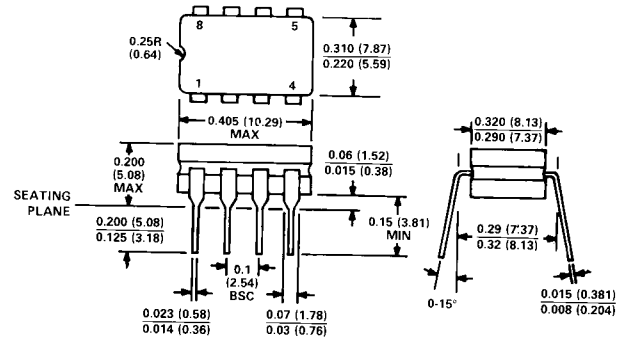

## Suffix JN

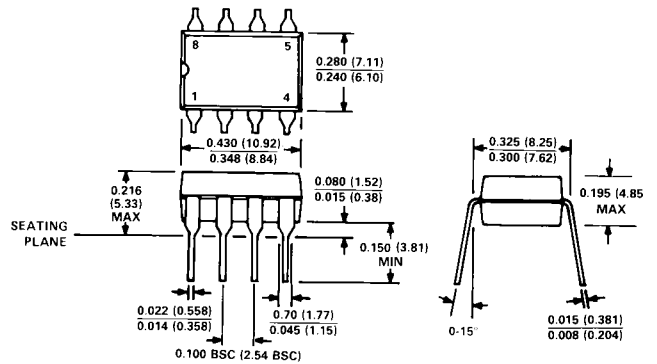

Side-Braced Package May Be Substituted for Model Suffixes AQ/BQ/SQ/TQ

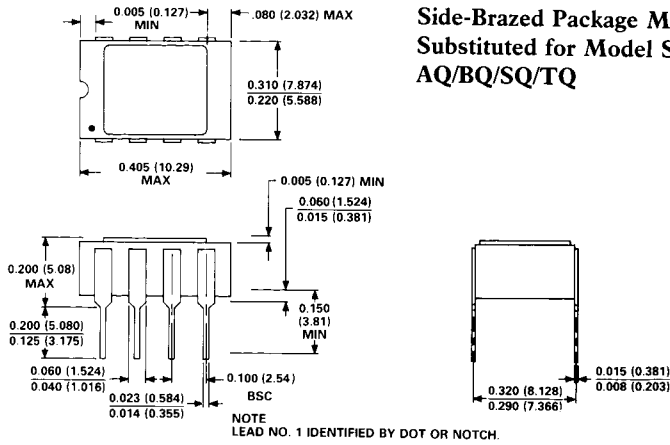

## Suffixes SZ/TZ

