

FEATURES
RF transceiver with integrated ADCs and DACs
IEEE 802.16 WiMAX
3.3 GHz to 3.8 GHz
3.5 MHz < BW < 20 MHz
Superior receiver sensitivity with NF 3.2 dB
Highly linear and spectrally pure transmitter
Tx EVM: -36 dB
SNR > 134 dB/Hz at f_{OFFSET} > 22 MHz
Tx power control
Range: 0 dB to 58 dB
Resolution: 0.25 dB
Autonomous AGC and Tx power control
Automatic frequency correction < 0.012 ppm
Integrated fractional-N synthesizer
8 Hz LO step size
Integrated phase noise < 0.8°rms
APPLICATIONS
WiMAX/BWA
GENERAL DESCRIPTION

The AD9353 is a fully integrated transceiver for IEEE 802.16 WiMAX wireless network systems. The RF MxFE® combines the RF front end with mixed-signal baseband enabling an easy-to-use digital interface to the baseband ASIC or FPGA. The AD9353 operates in the 3.3 GHz to 3.8 GHz range covering most of the licensed and unlicensed bands. Channel bandwidths of 3.5 MHz, 4.375 MHz, 5 MHz, 7 MHz, 8.75 MHz, 10 MHz, 14 MHz, 17.5 MHz, and 20 MHz are supported.

The direct-conversion receiver has state-of-the-art noise figure and linearity, and requires no external components with the exception of a balun. The complete RF subsystem integrates an autonomous AGC loop and dc offset corrections, thus eliminating the need for high speed interaction with the baseband processor. The received signal strength indicator (RSSI) has over 80 dB of dynamic range with 0.5 dB resolution and is accessible via the serial interface.

The received signal is digitized with a high dynamic range 12-bit ADC. Decimation and channel filters produce a 10-bit output signal at the appropriate sample rate determined by the bandwidth mode. The transmit path takes 10-bit input data and interpolates before converting to the analog domain and upconverting to the carrier frequency.

FUNCTIONAL BLOCK DIAGRAM

Figure 1.

0704-001

The highly linear transmit path has excellent spectral purity with sideband noise less than -134 dBc/Hz at 22 MHz offset and offers EVM of -36 dB at 0 dBm output power. The transmit power is detected by an accurate power detector and autonomously controlled with a range of 58 dB and 0.25 dB steps. The output power can be calibrated at the factory by a single measurement.

The reference frequency is produced by an internal crystal oscillator that has a digital programmable frequency with 0.012 ppm resolution, thus reducing the total bill of materials of the device.

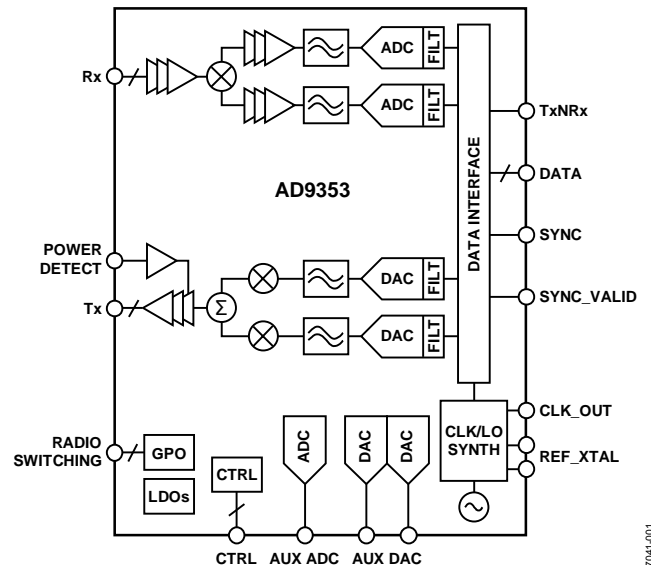
An internal auxiliary ADC and two auxiliary DACs are available for system monitoring and control. Three general-purpose I/Os are also included and can be register programmed or automatically sequenced by a user-defined state machine. Mode control is via a 4-wire serial port and four real-time I/O control pins.

The AD9353 is powered from a single 3.3 V supply and contains on-chip LDOs for each function to eliminate external regulators. The AD9353 is packaged in a 9 mm × 9 mm, 64-lead LFCSP.

For more information on the AD9353, email Analog Devices, Inc. at wimaxtransceivers@analog.com.

Rev. Sp0

Information furnished by Analog Devices is believed to be accurate and reliable. However, no responsibility is assumed by Analog Devices for its use, nor for any infringements of patents or other rights of third parties that may result from its use. Specifications subject to change without notice. No license is granted by implication or otherwise under any patent or patent rights of Analog Devices. Trademarks and registered trademarks are the property of their respective owners.

AD9353

NOTES