

FEATURES

- Four ADCs in one package
- Serial LVDS digital output data rates (ANSI-644)
- Data clock output provided
- On Chip Reference and SHA
- SNR = 70 dB at Fin up to Nyquist
- Excellent Linearity:
 - DNL = ± 0.3 LSB (Typical)
 - INL = ± 0.6 LSB (Typical)
- 500 MHz full power analog bandwidth
- Per Channel Core Power Dissipation = 270mW at 65MSPS / 200mW at 50MSPS
- 1 V_{pp} – 2 V_{pp} input voltage range
- +3.0 V supply operation
- Power down mode

APPLICATIONS

- Digital beam forming systems in ultrasound
- Wireless and wired broadband communications
- Communications test equipment
- Radar and satellite imaging sub-systems

PRODUCT DESCRIPTION

The AD9229 is a quad 12-bit monolithic sampling analog-to-digital converter with an on-chip track-and-hold circuit and is designed for low cost, low power, small size and ease of use. The product operates up to a 65 MSPS conversion rate and is optimized for outstanding dynamic performance where a small package size is critical.

The ADC requires a single +3.0 V power supply and a TTL/CMOS compatible sample rate clock for full performance operation. No external reference or driver components are required for many applications. A separate output power supply pin supports LVDS compatible serial digital output levels.

The ADC automatically multiplies up the sample rate clock for the appropriate LVDS serial data rate. An MSB trigger is provided to

FUNCTIONAL BLOCK DIAGRAM

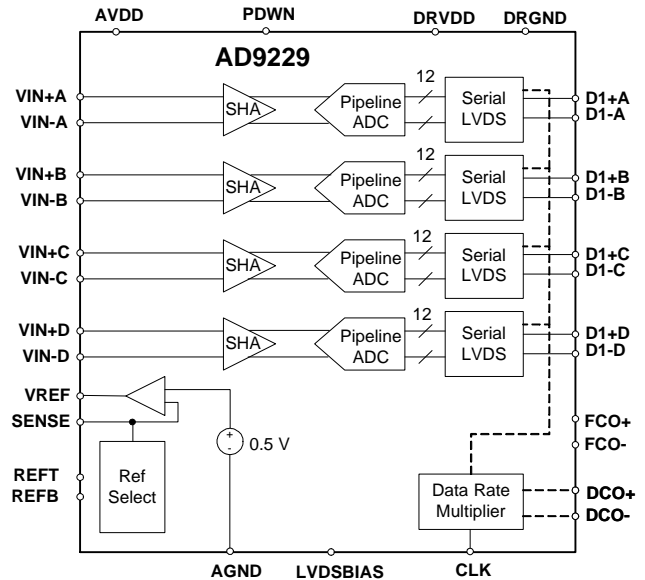

Figure 1. Functional Block Diagram

signal a new output byte. Power down is supported and consumes less than 3mW when enabled.

Fabricated on an advanced CMOS process, the AD9229 is available in a 48-LFCSFP package specified over the industrial temperature range (-40°C to $+85^{\circ}\text{C}$).

PRODUCT HIGHLIGHTS

1. Four analog-to-digital converters are contained in one small, space saving package.
2. A Data Clock Output (DCO) is provided which operates up to 390 MHz.
3. The outputs of each ADC are serialized with a maximum data output rate of 780 Mbps (12-bits x 65 MSPS).
4. The AD9229 operates from a single +3.0 V analog power supply.

Rev. PrF 10/06/2003

Information furnished by Analog Devices is believed to be accurate and reliable. However, no responsibility is assumed by Analog Devices for its use, nor for any infringements of patents or other rights of third parties that may result from its use. No license is granted by implication or otherwise under any patent or patent rights of Analog Devices. Trademarks and registered trademarks are the property of their respective companies.

TABLE OF CONTENTS

| | | | |
|---|----|---------------------------------|----|
| AD9229—Specifications | 3 | Analog Inputs | 11 |
| DIGITAL SPECIFICATIONS | 4 | Voltage Reference | 11 |
| AC SPECIFICATIONS..... | 4 | Digital Outputs | 11 |
| SWITCHING SPECIFICATIONS..... | 5 | Timing | 11 |
| EXPLANATION OF TEST LEVELS..... | 5 | PLL | 11 |
| Absolute Maximum Ratings | 6 | Pin Function Descriptions | 12 |
| Equivalent circuits..... | 7 | Pin Configurations | 13 |
| TYPICAL PERFORMANCE CHARACTERISTICS | 8 | Timing Diagram | 14 |
| Theory of Operation..... | 11 | Ordering Guide | 15 |

REVISION HISTORY

Revision PrA: Initial Version

Revision PrB: Added Definition and Theory of Operation sections, updated Pin Configurations

Revision PrC: Deleted demux outputs

Revision PrD: Added Pin Info, Package Info

Revision PrE: Ch. 3.3V to 3.0V for supply, Updated Sinad spec typo, Added analog typical Cin, Overrange Recovery Time, Latency

Revision PrF: Added 50MSPS Grade, Removed Clk-, Updated Power, SNR,LVDS Rset, Tpd Estimates, Added Equiv Ckts, Added FFT, VREF figure, Corrected FCO, DCO polarity timing

AD9229—SPECIFICATIONS¹

AVDD = 3.0V, DRVDD = 3.0V; INTERNAL REFERENCE; DIFFERENTIAL ANALOG INPUTS, MAXIMUM SAMPLE RATE, T_{MIN} TO T_{MAX}, UNLESS OTHERWISE NOTED

| Parameter | Temp | Test Level | AD9229BCP-50 | | | AD9229BCP-65 | | | Unit | |
|-----------------------------|-------------------------------------|------------|--------------|-----|------------|--------------|-----|------------|-----------------|------|
| | | | Min | Typ | Max | Min | Typ | Max | | |
| RESOLUTION | | | | 12 | | | 12 | | Bits | |
| ACCURACY | No Missing Codes | Full | VI | | Guaranteed | | | Guaranteed | | |
| | Offset Error | 25°C | I | | ± 0.5 | | | ± 0.5 | mV | |
| | Gain Error | 25°C | I | | ± 0.5 | | | ± 0.5 | %FS | |
| | Offset Matching | 25°C | I | | | | | | mV | |
| | Gain Matching ² | 25°C | I | | | | | | %FS | |
| | Differential Nonlinearity (DNL) | 25°C | I | | | ± 0.3 | | | ± 0.3 | LSB |
| | | Full | VI | | | | | | | LSB |
| Integral Nonlinearity (INL) | 25°C | I | | | ± 0.6 | | | ± 0.6 | LSB | |
| | Full | VI | | | | | | | LSB | |
| TEMPERATURE DRIFT | Offset Error | Full | V | | | | | | ppm/°C | |
| | Gain Error ² | Full | V | | | | | | ppm/°C | |
| | Reference | Full | V | | | | | | ppm/°C | |
| REFERENCE | Internal Reference Voltage | 25°C | I | | 0.5 | | | 0.5 | V | |
| | Output Current | Full | V | | | | | | uA | |
| | Input Current | Full | V | | | | | | uA | |
| | Input Resistance | Full | V | | | | | | kΩ | |
| ANALOG INPUTS | Differential Input Voltage Range | | | | 1 – 2 | | | 1 – 2 | V _{pp} | |
| | Common Mode Voltage | Full | V | | 1.5 | | | 1.5 | V | |
| | Input Capacitance | Full | V | | 7 | | | 7 | pF | |
| | Analog Bandwidth, Full Power | Full | V | | 500 | | | 500 | MHz | |
| POWER SUPPLY | AVDD | Full | IV | 2.7 | 3.0 | 3.6 | 2.7 | 3.0 | 3.6 | V |
| | DRVDD | Full | IV | 2.7 | 3.0 | 3.6 | 2.7 | 3.0 | 3.6 | V |
| | Power Dissipation ³ | Full | VI | | 940 | | | 1250 | | mW |
| | Power Down Dissipation | Full | VI | | <3 | | | <3 | | mW |
| | Power Supply Rejection Ratio (PSRR) | 25°C | I | | | | | | | mV/V |
| | IAVDD ³ | Full | VI | | 268 | | | 367 | | mA |
| | IDRVDD ³ | Full | VI | | 28 | | | 30 | | mA |
| IPLLVD ³ | Full | VI | | 18 | | | 19 | | | |

Table 1: DC Specifications

¹ Specifications subject to change without notice

² Gain error and gain temperature coefficients are based on the ADC only (with a fixed 0.5 V external reference and a 1 V p-p differential analog input).

³ Power dissipation measured with rated encode and a dc analog input (Outputs Static, I_{VDD} = 0). I_{VCC} and I_{VDD} measured with TBD MHz analog input @ 0.5dBFS.

DIGITAL SPECIFICATIONS

AVDD = 3.0V, DRVDD = 3.0V

| Parameter | | Temp | Test Level | AD9229BCP-50 | | | AD9229BCP-65 | | | Unit |
|------------------------------|--|------|------------|---------------|-----|-------|---------------|-----|-------|------|
| | | | | Min | Typ | Max | Min | Typ | Max | |
| CLOCK INPUT | V _{IH} | Full | IV | 2.0 | | | 2.0 | | | V |
| | V _{IL} | Full | IV | | | 0.8 | | | 0.8 | V |
| | Input Capacitance | 25°C | IV | | 2 | | | 2 | | pF |
| PDWN INPUT | Logic '1' Voltage | Full | IV | 2.0 | | | 2.0 | | | V |
| | Logic '0' Voltage | Full | IV | | | 0.8 | | | 0.8 | V |
| | Input Capacitance | Full | IV | | 2 | | | 2 | | PF |
| DIGITAL OUTPUTS (LVDS Mode)* | Differential Output Voltage (V _{OD}) | Full | IV | 247 | | 454 | 247 | | 454 | mV |
| | Output Offset Voltage (V _{OS}) | Full | IV | 1.125 | | 1.375 | 1.125 | | 1.375 | V |
| | Output Coding | Full | IV | Offset Binary | | | Offset Binary | | | |

Table 2: Digital Specifications

* LVDS Rset resistor = 3.6K, LVDS Output Termination Resistor= 100 Ohms.

AC SPECIFICATIONS¹AVDD = 3.0V, DRVDD = 3.0V; INTERNAL REFERENCE; DIFFERENTIAL ANALOG INPUTS, MAXIMUM SAMPLE RATE, T_{MIN} TO T_{MAX}, UNLESS OTHERWISE NOTED

| Parameter | Temp | Test Level | AD9229BCP-50 | | | AD9229BCP-65 | | | Unit | |
|---|--|------------|--------------|-----|------|--------------|-----|------|------|------|
| | | | Min | Typ | Max | Min | Typ | Max | | |
| SIGNAL TO NOISE RATIO (SNR) – Without Harmonics | f _{IN} = 10.3 MHz | 25°C | V | | 70.5 | | | 70.5 | | dB |
| | f _{IN} = 19.6 MHz | 25°C | V | | | | | | | dB |
| | f _{IN} = 32.5 MHz | 25°C | I | | 69.7 | | | 69.7 | | dB |
| | f _{IN} = 51 MHz | 25°C | V | | | | | | | dB |
| SIGNAL TO NOISE RATIO (SINAD) – With Harmonics | f _{IN} = 10.3 MHz | 25°C | V | | 70.3 | | | 70.3 | | dB |
| | f _{IN} = 19.6 MHz | 25°C | V | | | | | | | dB |
| | f _{IN} = 32.5 MHz | 25°C | I | | 69.5 | | | 69.5 | | dB |
| | f _{IN} = 51 MHz | 25°C | V | | | | | | | dB |
| EFFECTIVE NUMBER OF BITS (ENOB) | f _{IN} = 10.3 MHz | 25°C | V | | | | | | | Bits |
| | f _{IN} = 19.6 MHz | 25°C | V | | | | | | | Bits |
| | f _{IN} = 32.5 MHz | 25°C | I | | | | | | | Bits |
| | f _{IN} = 51 MHz | 25°C | V | | | | | | | Bits |
| SPURIOUS FREE DYNAMIC RANGE (SFDR) | f _{IN} = 10.3 MHz | 25°C | V | | | | | | | dB |
| | f _{IN} = 19.6 MHz | 25°C | V | | 85 | | | 85 | | dB |
| | f _{IN} = 32.5 MHz | 25°C | I | | | | | | | dB |
| | f _{IN} = 51 MHz | 25°C | V | | | | | | | dB |
| SECOND AND THIRD HARMONIC DISTORTION | f _{IN} = 10.3 MHz | 25°C | V | | | | | | | dBc |
| | f _{IN} = 19.6 MHz | 25°C | V | | -85 | | | -85 | | dBc |
| | f _{IN} = 32.5 MHz | 25°C | I | | | | | | | dBc |
| | f _{IN} = 51 MHz | 25°C | V | | | | | | | dBc |
| TWO TONE INTERMOD DISTORTION (IMD) | f _{IN1} = 19 MHz, f _{IN2} = 20 MHz | 25°C | V | | -85 | | | -85 | | dBc |
| | f _{IN1} = xx MHz, f _{IN2} = xx MHz | 25°C | V | | | | | | | dBc |

¹ SNR/harmonics based on an analog input voltage of –0.5 dBFS referenced to a 1 Vpp full-scale input range.

| Parameter | Temp | Test Level | AD9229BCP-50 | | | AD9229BCP-65 | | | Unit | |
|-----------|------|------------|--------------|-----|-----|--------------|-----|-----|------|----|
| | | | Min | Typ | Max | Min | Typ | Max | | |
| CROSSTALK | | Full | V | | -80 | | | -80 | | dB |

Table 3: AC Specifications

SWITCHING SPECIFICATIONS

AVDD = 3.0 V, DRVDD = 3.0 V; DIFFERENTIAL ENCODE INPUT

| Parameter | Temp | Test Level | AD9229BCP-50 | | | AD9229BCP-65 | | | Unit | |
|--------------------------------|--|------------|--------------|-----|-----|--------------|-----|-----|------|--------|
| | | | Min | Typ | Max | Min | Typ | Max | | |
| CLOCK | Clock Rate | Full | VI | 10 | | 50 | 10 | | 65 | MSPS |
| | Clock Pulse Width High (t_{EH}) | Full | IV | | | | | | | ns |
| | Clock Pulse Width Low (t_{EL}) | Full | IV | | | | | | | ns |
| OUTPUT PARAMETERS IN LVDS MODE | Valid Time (t_V) ¹ | Full | VI | | | | | | | ns |
| | Propagation Delay (t_{PD}) ¹ | Full | VI | | 5 | | | 5 | | ns |
| | MSB Propagation Delay (t_{MSB}) ¹ | Full | VI | | 5 | | | 5 | | ns |
| | Rise Time (t_R) (20% to 80%) | Full | V | | | | | | | ns |
| | Fall Time (t_F) (20% to 80%) | Full | V | | | | | | | ns |
| | DCO Propagation Delay (t_{CPD}) | Full | VI | | 5 | | | 5 | | ns |
| | Data to DCO Skew ($t_{PD} - t_{CPD}$) | Full | IV | | | | | | | ns |
| | Pipeline Latency | Full | VI | | 9 | | | 9 | | cycles |
| APERTURE | Aperture Delay (t_A) | 25°C | V | | | | | | | ps |
| | Aperture Uncertainty (Jitter) | 25°C | V | | <1 | | | <1 | | ps rms |
| Out of Range Recovery Time | Full | IV | | | 2 | | | 2 | | cycles |

Table 4: Switching Specifications

EXPLANATION OF TEST LEVELS

TEST LEVEL

- I 100% production tested.
- II 100% production tested at +25°C and guaranteed by design and characterization at specified temperatures.
- III Sample tested only.
- IV Parameter is guaranteed by design and characterization testing.
- V Parameter is a typical value only.
- VI 100% production tested at +25°C and guaranteed by design and characterization for industrial temperature range.

¹ t_V and t_{PD} are measured from the transition points of the CLK input to the 50%/50% levels of the digital outputs swing. The digital output load during test is not to exceed an ac load of 5 pF or a dc current of $\pm 40 \mu A$. Rise and fall times measured from 20% to 80%.

ABSOLUTE MAXIMUM RATINGS

| | Parameter | Rating |
|---------------|---------------------------------------|----------------|
| Electrical | AVDD Voltage | 3.9V |
| | DRVDD Voltage | 3.9V |
| | Analog Input Voltage | |
| | Analog Input Current | |
| | Digital Input Voltage | |
| | Digital Output Current | |
| | VREF Input Voltage | |
| Environmental | Operating Temperature Range (Ambient) | -40°C to +85°C |
| | Maximum Junction Temperature | 150°C |
| | Lead Temperature (Soldering, 10 sec) | |
| | Maximum Case Temperature | |
| | Storage Temperature Range (Ambient) | |

Table 5: Absolute Maximum Ratings

Stresses above those listed under the Absolute Maximum Ratings may cause permanent damage to the device. This is a stress rating only; functional operation of the device at these or any other conditions above those indicated in the operational section of this specification is not implied. Exposure to absolute maximum rating conditions for extended periods may affect device reliability.

EQUIVALENT CIRCUITS

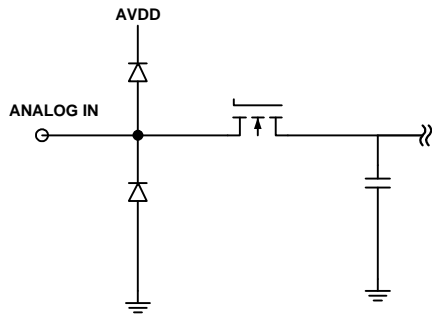

Figure 2 Analog Inputs

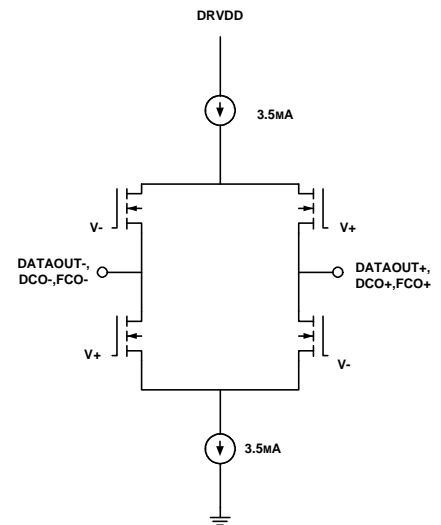

Figure 4 LVDS Outputs

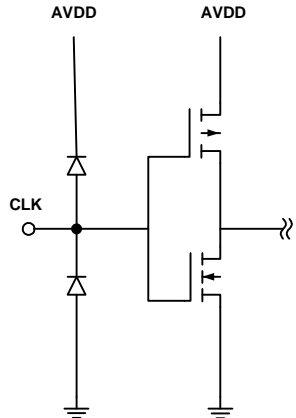

Figure 3 Clock Input

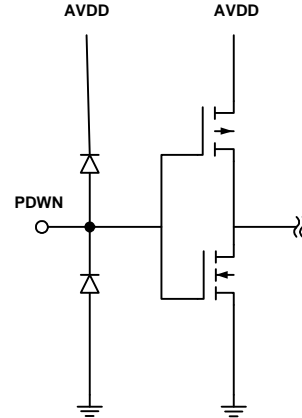
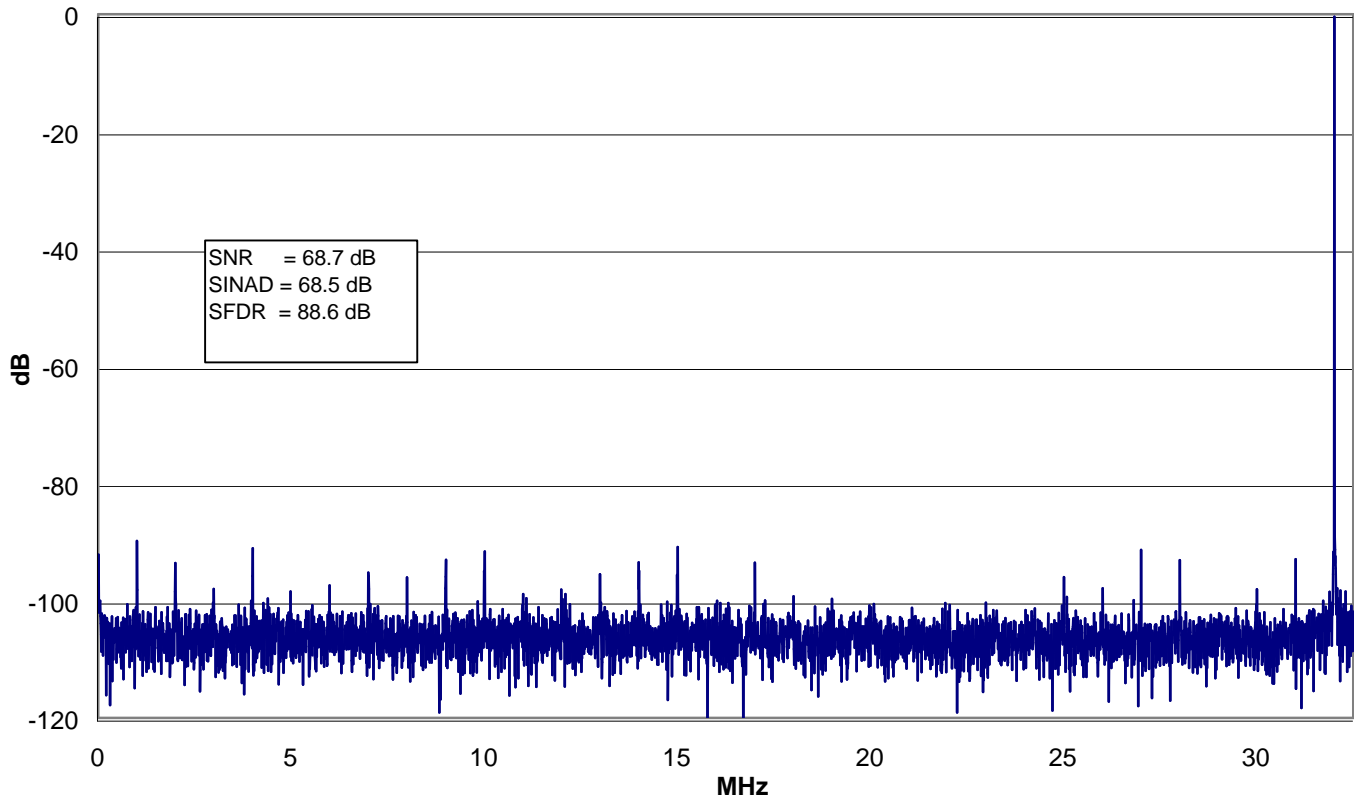

Figure 5 PDWN Input

TYPICAL PERFORMANCE CHARACTERISTICS



Measured FFT Performance 32MHz Ain at 65MSPS

Definitions

ANALOG BANDWIDTH

The analog input frequency at which the spectral power of the fundamental frequency (as determined by the FFT analysis) is reduced by 3 dB.

APERTURE DELAY

The delay between the 50% point of the rising edge of the ENCODE command and the instant at which the analog input is sampled.

APERTURE UNCERTAINTY (JITTER)

The sample-to-sample variation in aperture delay.

CROSSTALK

Coupling onto one channel being driven by a low level (-40 dBFS) signal when the adjacent interfering channel is driven by a full-scale signal.

DIFFERENTIAL ANALOG INPUT RESISTANCE, DIFFERENTIAL ANALOG INPUT CAPACITANCE, AND DIFFERENTIAL ANALOG INPUT IMPEDANCE

The real and complex impedances measured at each analog input port. The resistance is measured statically and the capacitance and differential input impedances are measured with a network analyzer.

DIFFERENTIAL ANALOG INPUT VOLTAGE RANGE

The peak to peak differential voltage that must be applied to the converter to generate a full scale response. Peak differential voltage is computed by observing the voltage on a single pin and subtracting the voltage from the other pin, which is 180 degrees out of phase. Peak to peak differential is computed by rotating the inputs phase 180 degrees and taking the peak measurement again. Then the difference is computed between both peak measurements.

DIFFERENTIAL NONLINEARITY

The deviation of any code width from an ideal 1 LSB step.

EFFECTIVE NUMBER OF BITS

The effective number of bits (ENOB) is calculated from the measured SNR based on the equation:

$$ENOB = \frac{SNR_{MEASURED} - 1.76dB}{6.02}$$

ENCODE PULSE WIDTH/DUTY CYCLE

Pulse width high is the minimum amount of time that the ENCODE pulse should be left in logic “1” state to achieve rated performance; pulse width low is the minimum time ENCODE pulse should be left in low state. See timing implications of changing tENCH in text. At a give clock rate, these specs define an acceptable Encode duty cycle.

FULL SCALE INPUT POWER

Expressed in dBm. Computed using the following equation:

$$Power_{Fullscale} = 10 \log \left(\frac{V_{Fullscale_{rms}}^2}{Z_{Input} \cdot .001} \right)$$

GAIN ERROR

Gain error is the difference between the measured and ideal full scale input voltage range of the worst ADC.

GAIN MATCHING

Expressed in %FSR. Computed using the following equation:

$$GainMatching = \frac{FSR_{max} - FSR_{min}}{\left(\frac{FSR_{max} + FSR_{min}}{2} \right)} * 100\%$$

where FSR_{max} is the most positive gain error of the ADCs and FSR_{min} is the most negative gain error of the ADCs.

HARMONIC DISTORTION, SECOND

The ratio of the rms signal amplitude to the rms value of the second harmonic component, reported in dBc.

HARMONIC DISTORTION, THIRD

The ratio of the rms signal amplitude to the rms value of the third harmonic component, reported in dBc.

INTEGRAL NONLINEARITY

The deviation of the transfer function from a reference line measured in fractions of 1 LSB using a “best straight line” determined by a least square curve fit.

MINIMUM CONVERSION RATE

The encode rate at which the SNR of the lowest analog signal frequency drops by no more than 3 dB below the guaranteed limit.

MAXIMUM CONVERSION RATE

The encode rate at which parametric testing is performed.

OFFSET ERROR

Offset error is the difference between the measured and ideal voltage at the analog input that produces the midscale code at the outputs. Offset error is given for the worst ADC.

OFFSET MATCHING

Expressed in mV. Computed using the following equation:

$$\text{OffsetMatching} = \text{OFF}_{\max} - \text{OFF}_{\min}$$

where OFF_{\max} is the most positive offset error and OFF_{\min} is the most negative offset error.

OUTPUT PROPAGATION DELAY

The delay between a differential crossing of CLK+ and CLK- and the time when all output data bits are within valid logic levels.

NOISE (FOR ANY RANGE WITHIN THE ADC)

$$V_{\text{noise}} = \sqrt{Z * .001 * 10 \left(\frac{FS_{dBm} - SNR_{dBc} - Signal_{dBFS}}{10} \right)}$$

Where Z is the input impedance, FS is the full scale of the device for the frequency in question, SNR is the value for the particular input level and Signal is the signal level within the ADC reported in dB below full scale. This value includes both thermal and quantization noise.

POWER SUPPLY REJECTION RATIO

The ratio of a change in input offset voltage to a change in power supply voltage.

SIGNAL-TO-NOISE-AND-DISTORTION (SINAD)

The ratio of the rms signal amplitude (set 1 dB below full scale) to

the rms value of the sum of all other spectral components, including harmonics but excluding dc.

SIGNAL-TO-NOISE RATIO (WITHOUT HARMONICS)

The ratio of the rms signal amplitude (set at 1 dB below full scale) to the rms value of the sum of all other spectral components, excluding the first five harmonics and dc.

SPURIOUS-FREE DYNAMIC RANGE (SFDR)

The ratio of the rms signal amplitude to the rms value of the peak spurious spectral component. The peak spurious component may or may not be a harmonic. It also may be reported in dBc (i.e., degrades as signal level is lowered) or dBFS (i.e., always related back to converter full scale).

TWO-TONE INTERMODULATION DISTORTION REJECTION

The ratio of the rms value of either input tone to the rms value of the worst third order intermodulation product; reported in dBc.

TWO-TONE SFDR

The ratio of the rms value of either input tone to the rms value of the peak spurious component. The peak spurious component may or may not be an IMD product. It also may be reported in dBc (i.e., degrades as signal level is lowered) or in dBFS (i.e., always relates back to converter full scale).

WORST OTHER SPUR

The ratio of the rms signal amplitude to the rms value of the worst spurious component (excluding the second and third harmonic) reported in dBc.

TRANSIENT RESPONSE TIME

Transient response time is defined as the time it takes for the ADC to reacquire the analog input after a transient from 10% above negative full scale to 10% below positive full scale.

OUT-OF-RANGE RECOVERY TIME

Out of range recovery time is the time it takes for the ADC to reacquire the analog input after a transient from 10% above positive full scale to 10% above negative full scale, or from 10% below negative full scale to 10% below positive full scale.

THEORY OF OPERATION

Analog Inputs

For best dynamic performance, the source impedances driving VIN+ and VIN- should be matched such that common-mode settling errors are symmetrical. These errors will be reduced by the common-mode rejection of the A/D.

Voltage Reference

The AD9229 has a stable and accurate reference voltage on chip, which sets the full-scale voltage at the analog input channels. Internal reference mode is established by grounding the SENSE pin. (Recommended decoupling capacitors shown below) The internal reference can be bypassed by setting SENSE to AVDD and driving VREF with an external 1V reference.

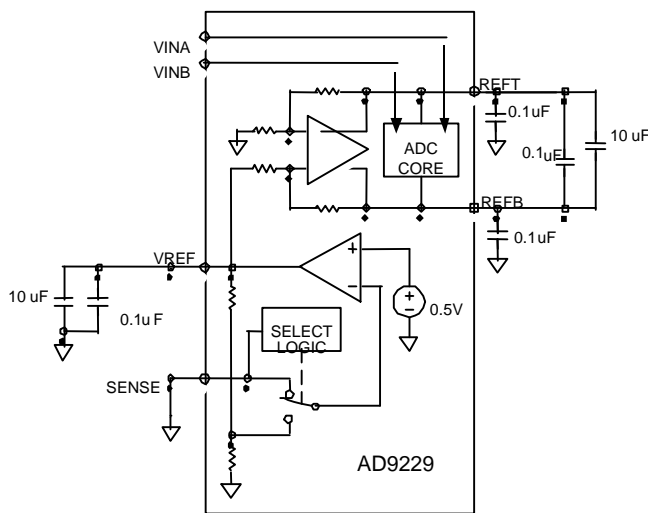

Internal Reference Mode Connection

Digital Outputs

The AD9229's differential outputs conform to the ANSI-644 LVDS standard. To set the LVDS bias current, place a resistor (RSET is nominally equal to 3.6 k Ω) to ground at the LVDSBIAS pin. The RSET resistor current ($\sim 1.2/RSET$) is ratioed on-chip setting the output current at each output equal to a nominal 3.5 mA. A 100 Ω differential termination resistor placed at the LVDS receiver inputs results in a nominal 350 mV swing at the receiver.

The AD9229's LVDS outputs facilitate interfacing with LVDS receivers in custom ASICs and FPGAs that have LVDS capability for superior switching performance in noisy environments. Single point-to-point net topologies are recommended with a 100 Ω termination resistor as close to the receiver as possible. It is

recommended to keep the trace length no longer than 1–2 inches and to keep differential output trace lengths as equal as possible.

The format of the output data is offset binary.

Timing

Data from each A/D is serialized and provided on a separate channel.

Two output clocks are provided to assist in capturing data from the AD9229. The data clock out (DCO) is used to clock the output data and is equal to 6 times the sample clock frequency. (390MHz for 65MHz input clock) Data is clocked out of the AD9229 on the rising and falling edges of DCO. The FCO clock signals the start of a new serial word, the rising edge of FCO occurs at the start of an MSB.

PLL

The AD9229 contains an internal PLL that is used to generate internal clocking signals, if the PLL is unlocked, the data outputs are static.

PIN FUNCTION DESCRIPTIONS

| Pin No. | Name | Description | Pin No. | Name | Description |
|---------------------|--------|-----------------------------------|---------|----------|---|
| 8,16,21,29 | AVDD | 3.0 V Analog Supply | 44 | D+A | ADC A True Digital Output |
| 9,12,15,22,25,28,31 | AGND | Analog Ground | 43 | D-A | ADC A Complement Digital Output |
| 2,35 | DRVDD | 3.0 V Digital Output Supply | 42 | D+B | ADC B True Digital Output |
| 1,36 | DRGND | Digital Ground | 41 | D-B | ADC B Complement Digital Output |
| 32 | PLLVDD | PLL 3.0V Supply | 40 | D+C | ADC C True Digital Output |
| 33 | PLLGND | PLL Ground | 39 | D-C | ADC C Complement Digital Output |
| 30 | CLK | Input Clock | 38 | D+D | ADC D True Digital Output |
| 18 | VREF | Voltage Reference Input/Output | 37 | D1-D | ADC D Complement Digital Output |
| 17 | SENSE | Reference Mode Selection | 48 | DCO+ | Data Clock Output – True |
| 20 | REFT | Differential Reference (Positive) | 47 | DCO- | Data Clock Output – Complement |
| 19 | REFB | Differential Reference (Negative) | 46 | FCO+ | Frame Clock Indicator – True Output |
| 10 | VIN+A | ADC A Analog Input – True | 45 | FCO- | Frame Clock Indicator – Complement Output |
| 11 | VIN-A | ADC A Analog Input – Complement | 34 | LVDSBIAS | LVDS Output Current Set Resistor Pin |
| 14 | VIN+B | ADC B Analog Input – True | 7 | PDWN | Power Down Selection (Logic '1' = Power Down) |
| 13 | VIN-B | ADC B Analog Input – Complement | 3,4,5,6 | DNC | Do Not Connect |
| 23 | VIN+C | ADC C Analog Input – True | | | |
| 24 | VIN-C | ADC C Analog Input – Complement | | | |
| 27 | VIN+D | ADC D Analog Input – True | | | |
| 26 | VIN-D | ADC D Analog Input – Complement | | | |

Table 6: Pin Function Descriptions

PIN CONFIGURATIONS

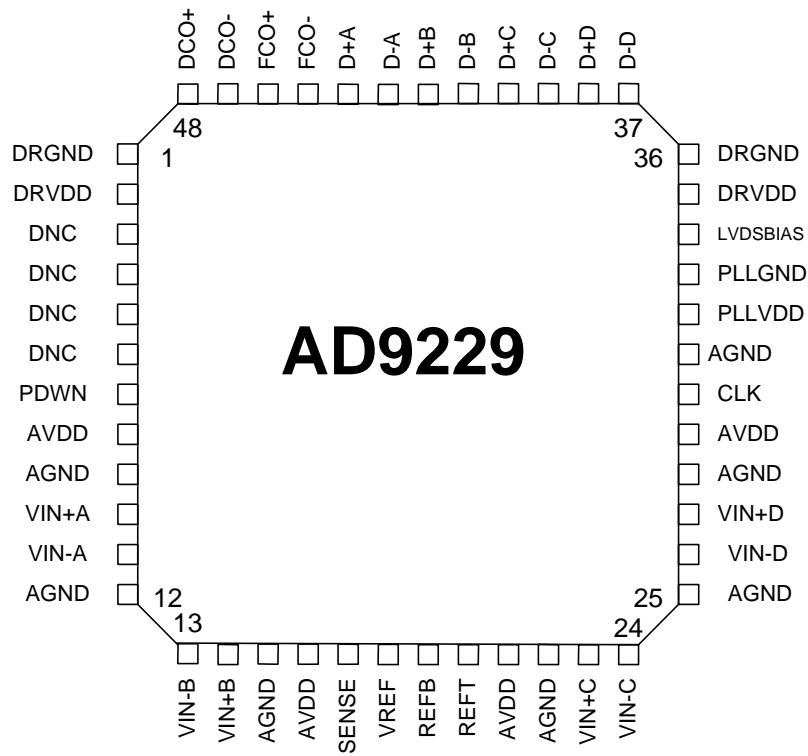

TIMING DIAGRAM

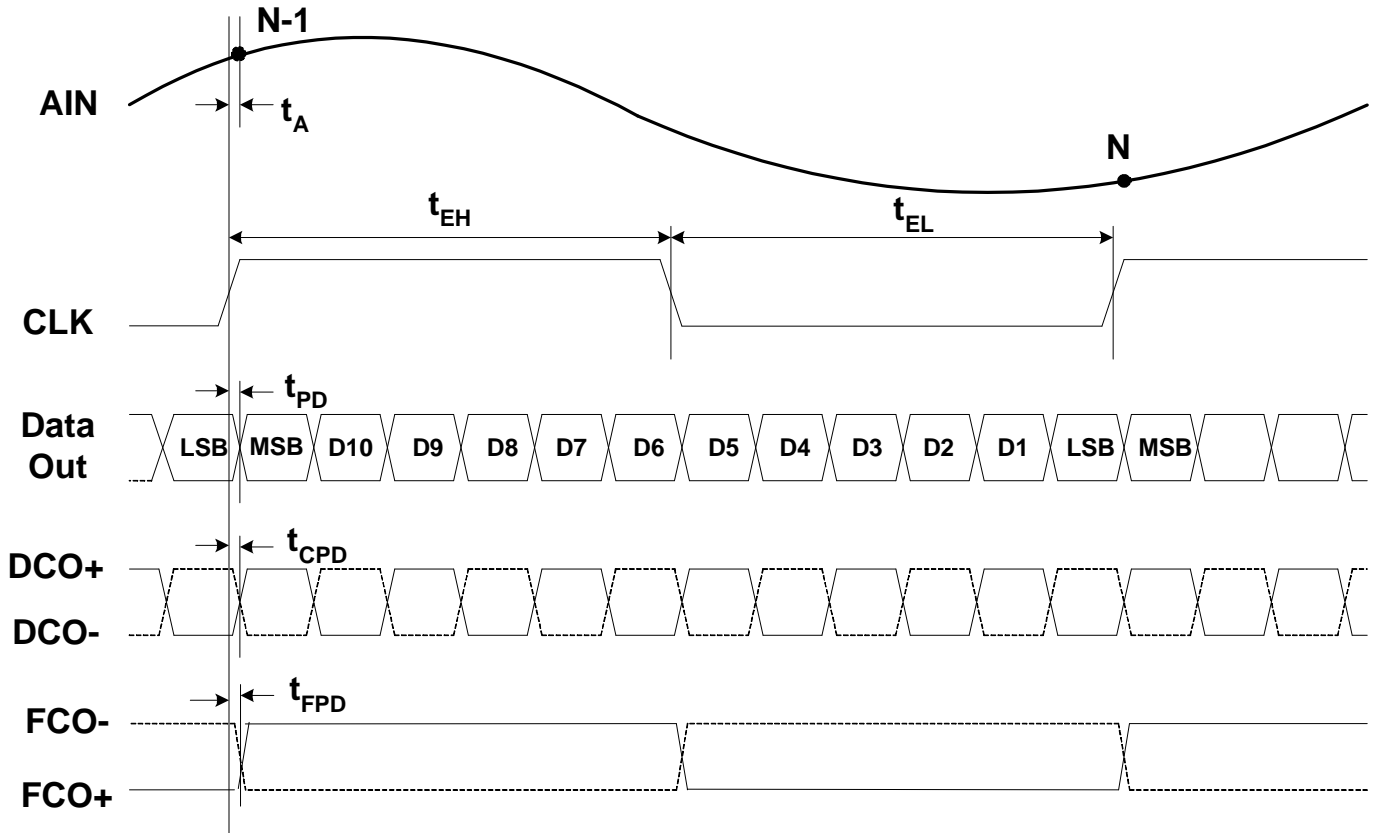

Figure 6: Serial LVDS Outputs

NOTE: Latency = 9 cycles

OUTLINE DIMENSIONS



48-Lead Frame Chip Scale Package [LFCSP]
(CP-48)

Dimensions shown in millimeters

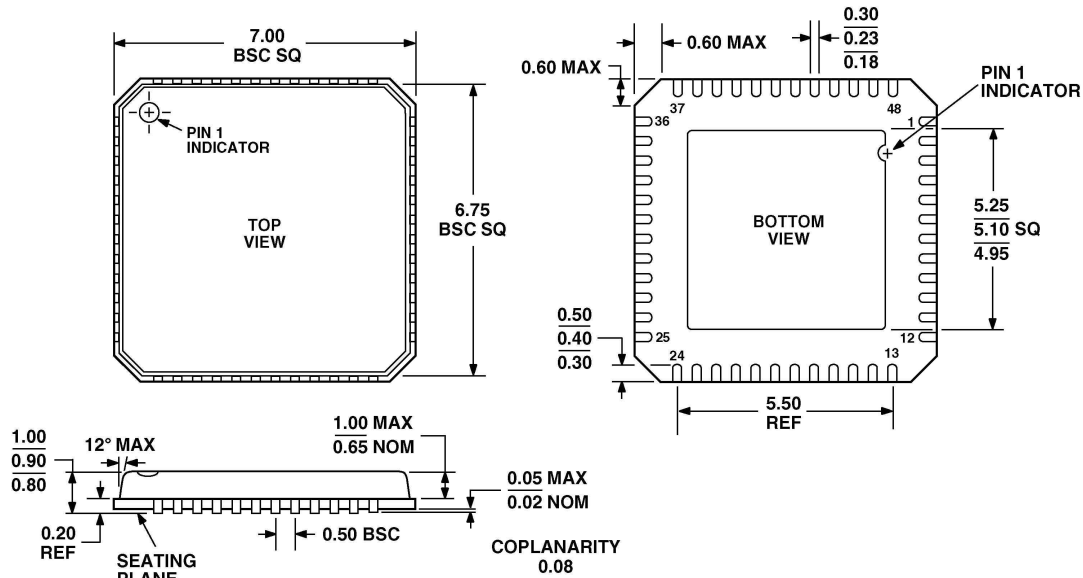

COMPLIANT TO JEDEC STANDARDS MO-220-VKGD-2

Figure 7

ESD CAUTION

ESD (electrostatic discharge) sensitive device. Electrostatic charges as high as 4000 V readily accumulate on the human body and test equipment and can discharge without detection. Although this product features proprietary ESD protection circuitry, permanent damage may occur on devices subjected to high energy electrostatic discharges. Therefore, proper ESD precautions are recommended to avoid performance degradation or loss of functionality.



Ordering Guide

| Model | Temperature Range | Description |
|--------------|--------------------------|--|
| AD9229BCP-50 | -40°C to +85°C (Ambient) | 48-LFCSP |
| AD9229BCP-65 | -40°C to +85°C (Ambient) | 48-LFCSP |
| AD9229/PCB | 25°C (Ambient) | Evaluation Board (Supplied with -65 Grade) |

Table 7: Ordering Guide

