

FEATURES

- Qualified for automotive applications
- High common-mode voltage range
–8 V to +28 V operating at 5 V supply
- Buffered output voltage
- Gain = 20 V/V
- Low-pass filter (1-pole or 2-pole)
- Excellent ac and dc performance
 - ±1 mV voltage offset
 - 1 ppm/°C typical gain drift
 - 80 dB CMRR minimum dc to 10 kHz
- Known good die (KGD): these die are fully guaranteed to data sheet specifications

APPLICATIONS

- High-side current sensing
 - Motor controls
 - Solenoid controls
 - Power management
- Low-side current sensing
- Diagnostic protection

GENERAL DESCRIPTION

The [AD8202-KGD](#) is a single-supply difference amplifier ideal for amplifying and low-pass filtering small differential voltages in the presence of a large common-mode voltage. The input common-mode voltage range extends from –8 V to +28 V at a single +5 V supply. The [AD8202-KGD](#) is qualified for automotive applications.

Automotive applications demand robust, precision components for improved system control. The [AD8202-KGD](#) provides excellent ac and dc performance, minimizing errors in the application.

FUNCTIONAL BLOCK DIAGRAM

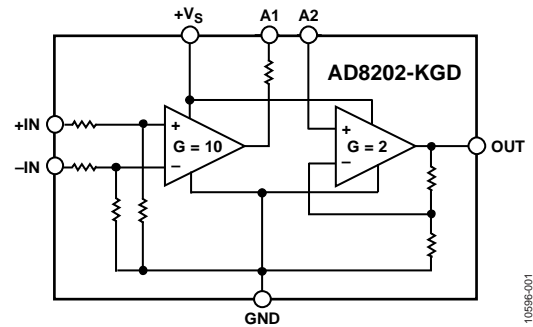

Figure 1.

10596-001

Typical offset and gain drift are 5 $\mu\text{V}/^\circ\text{C}$ and 1 ppm/°C respectively. The device also delivers a minimum CMRR of 80 dB from dc to 10 kHz.

The [AD8202-KGD](#) features an externally accessible 100 k Ω resistor at the output of the preamplifier (A1), which can be used for low-pass filtering and for establishing gains other than 20.

Additional application and technical information can be found in the [AD8202](#) data sheet.

Rev. 0

Information furnished by Analog Devices is believed to be accurate and reliable. However, no responsibility is assumed by Analog Devices for its use, nor for any infringements of patents or other rights of third parties that may result from its use. Specifications subject to change without notice. No license is granted by implication or otherwise under any patent or patent rights of Analog Devices. Trademarks and registered trademarks are the property of their respective owners.

TABLE OF CONTENTS

Features	1	ESD Caution.....	4
Applications.....	1	Pad Configuration and Function Descriptions	5
Functional Block Diagram	1	Outline Dimensions	6
General Description	1	Die Specifications and Assembly Recommendations	6
Revision History	2	Ordering Guide	6
Specifications.....	3	Automotive Products.....	6
Absolute Maximum Ratings.....	4		

REVISION HISTORY

3/12—Revision 0: Initial Version

SPECIFICATIONS

$T_{OPR} = -40^{\circ}\text{C}$ to $+150^{\circ}\text{C}$, $T_A = 25^{\circ}\text{C}$, $V_S = 5\text{ V}$.

Table 1.

Parameter	Test Conditions	Min	Typ	Max	Unit
SYSTEM GAIN					
Initial			20		V/V
Error vs. Temperature	$0.02\text{ V} \leq V_{OUT} \leq 4.8$, dc @ T_A T_{OPR}	0		± 0.3 +30	% ppm/ $^{\circ}\text{C}$
VOLTAGE OFFSET					
Initial Offset (Referred to Input [RTI]) vs. Temperature	$V_{CM} = 0.15\text{ V}$, T_A $T = -40^{\circ}\text{C}$ to $+125^{\circ}\text{C}$ T_{OPR}			± 1 ± 10 ± 15	mV $\mu\text{V}/^{\circ}\text{C}$ $\mu\text{V}/^{\circ}\text{C}$
INPUT					
Input Impedance					
Differential		260	325	390	k Ω
Common Mode		135	170	205	k Ω
Input Common-Mode Voltage (V_{CM}), Continuous		-8		+28	V
CMRR ¹	$V_{CM} = -8\text{ V}$ to $+28\text{ V}$ $f = \text{dc}$ $f = 1\text{ kHz}$ $f = 10\text{ kHz}^2$	82			dB
		82			dB
		80			dB
PREAMPLIFIER (A1)					
Gain			10		V/V
Gain Error	$0.02\text{ V} \leq V_{OUT} \leq (V_S - 0.2\text{ V})$, dc, T_{OPR}			± 0.3	%
Output Voltage Range		0.02		4.8	V
Output Resistance		97	100	103	k Ω
OUTPUT BUFFER (A2)					
Gain			2		V/V
Gain Error	$0.02\text{ V} \leq V_{OUT} \leq 4.8\text{ V}$ dc			± 0.3	%
Output Voltage Range		0.02		4.8	V
Input Bias Current			40		nA
Output Resistance			2		Ω
DYNAMIC RESPONSE					
System Bandwidth	$V_{IN} = 0.1\text{ V p-p}$, $V_{OUT} = 2.0\text{ V p-p}$	30	50		kHz
Slew Rate	$V_{IN} = 0.2\text{ V}$ dc, $V_{OUT} = 4\text{ V}$ step		0.28		V/ μs
NOISE					
0.1 Hz to 10 Hz Spectral Density, 1 kHz (RTI)			10		$\mu\text{V p-p}$ nV/ $\sqrt{\text{Hz}}$
			275		
POWER SUPPLY					
Operating Range		3.5		12	V
Quiescent Current vs. Temperature	$V_{OUT} = 0.1\text{ V}$ dc		0.25	1.0	mA
PSRR	$V_S = 3.5\text{ V}$ to 12 V	75	83		dB
TEMPERATURE RANGE	For specified performance at T_{OPR}	-40		+150	$^{\circ}\text{C}$

¹ Source imbalance $< 2\ \Omega$.

² The AD8202-KGD preamplifier exceeds 80 dB CMRR at 10 kHz. However, because the output is available only by way of the 100 k Ω resistor, even a small amount of pin-to-pin capacitance between the IN pins and the A1 and A2 pins might couple an input common-mode signal larger than the greatly attenuated preamplifier output. The effect of pin-to-pin coupling can be negated in all applications by using a filter capacitor from Pin 3 to GND.

ABSOLUTE MAXIMUM RATINGS

Table 2.

Parameter	Rating
Supply Voltage	12.5 V
Continuous Input Voltage (Common Mode)	35 V
Reversed Supply Voltage Protection	0.3 V
Operating Temperature Range (Die)	-40°C to +150°C
Output Short-Circuit Duration	Indefinite
Lead Temperature Range (Soldering, 10 sec)	300°C

Stresses above those listed under Absolute Maximum Ratings may cause permanent damage to the device. This is a stress rating only; functional operation of the device at these or any other conditions above those indicated in the operational section of this specification is not implied. Exposure to absolute maximum rating conditions for extended periods may affect device reliability.

ESD CAUTION



ESD (electrostatic discharge) sensitive device. Charged devices and circuit boards can discharge without detection. Although this product features patented or proprietary protection circuitry, damage may occur on devices subjected to high energy ESD. Therefore, proper ESD precautions should be taken to avoid performance degradation or loss of functionality.

PAD CONFIGURATION AND FUNCTION DESCRIPTIONS

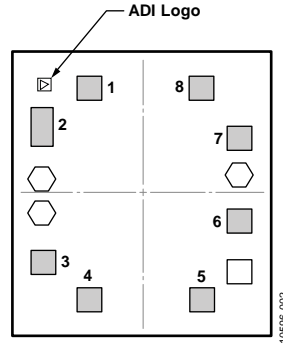

Figure 2. Pad Configuration

Table 3. Pad Function Descriptions

Pad No.	Coordinates		Mnemonic	Pad Type	Description
	X-Axis (μm)	Y-Axis (μm)			
1	-205	+409	-IN	Single	Inverting Input Pad
2	-413	+285	GND	Double	Ground Pad
3	-413	-229	A1	Single	Preamplifier (A1) Output Pad
4	-309	-410	A2	Single	Buffer (A2) Input Pad
5	+272	-410	OUT	Single	Buffer (A2) Output Pad
6	+417	-121	+Vs	Single	Supply Pad
7			NC		No Connect
8	+205	+409	+IN	Single	Noninverting Input Pad

OUTLINE DIMENSIONS

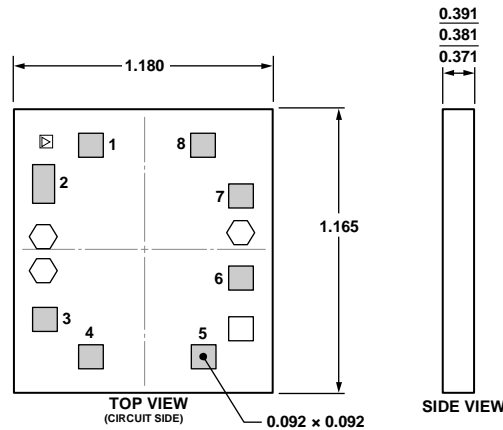

Figure 3. 8-Pad Bare Die [CHIP]
(C-8-1)
Dimensions shown in millimeters

DIE SPECIFICATIONS AND ASSEMBLY RECOMMENDATIONS

Table 4. Die Specifications

Parameter	Value	Unit ¹
Chip Size	1090 × 1105	μm
Scribe Line Width	75 × 75	μm
Die Size	1.180 × 1.165	mm (maximum)
Thickness	381 ± 10	μm
Bond Pad	92 × 92	μm (minimum)
Bond Pad Composition	0.5 AlCu	%
Backside	Bare	N/A
Passivation	Polymide	N/A

¹ N/A means not applicable.

Table 5. Assembly Recommendations

Assembly Component	Recommendation
Die Attach	No special requirements
Bonding Method	Gold ball or aluminum wedge
Bonding Sequence	Any

ORDERING GUIDE

Model ¹	Temperature Range	Package Option
AD8202W-KGD-R7	−40°C to +150°C	C-8-1

¹ W = Qualified for Automotive Applications.

AUTOMOTIVE PRODUCTS

The AD8202W model is available with controlled manufacturing to support the quality and reliability requirements of automotive applications. Note that this automotive model may have specifications that differ from the commercial models; therefore, designers should review the Specifications section of this data sheet carefully. Only the automotive grade product shown is available for use in automotive applications. Contact your local Analog Devices account representative for specific product ordering information and to obtain the specific Automotive Reliability reports for these models.

NOTES

NOTES