

AD590

2-Wire, Current Output Temperature Transducer

FN3171
 Rev.3.00
 January 2002

Features

- Linear Current Output1 μ A/ $^{\circ}$ K
- Wide Temperature Range..... -55 $^{\circ}$ C to 150 $^{\circ}$ C
- Two-Terminal Device Voltage In/Current Out
- Wide Power Supply Range +4V to +30V
- Sensor Isolation From Case
- Low Cost

Ordering Information

PART NUMBER	NON-LINEARITY ($^{\circ}$ C)	TEMP. RANGE ($^{\circ}$ C)	PACKAGE	PKG. NO.
AD590JH	± 1.5	-55x to 150x	3 Ld Metal Can (TO-52)	T3.A

Description

The AD590 is an integrated-circuit temperature transducer which produces an output current proportional to absolute temperature. The device acts as a high impedance constant current regulator, passing 1 μ A/ $^{\circ}$ K for supply voltages between +4V and +30V. Laser trimming of the chip's thin film resistors is used to calibrate the device to 298.2 μ A output at 298.2 $^{\circ}$ K (25 $^{\circ}$ C).

The AD590 should be used in any temperature-sensing application between -55 $^{\circ}$ C to 150 $^{\circ}$ C in which conventional electrical temperature sensors are currently employed. The inherent low cost of a monolithic integrated circuit combined with the elimination of support circuitry makes the AD590 an attractive alternative for many temperature measurement situations. Linearization circuitry, precision voltage amplifiers, resistance measuring circuitry and cold junction compensation are not needed in applying the AD590. In the simplest application, a resistor, a power source and any voltmeter can be used to measure temperature.

In addition to temperature measurement, applications include temperature compensation or correction of discrete components, and biasing proportional to absolute temperature.

The AD590 is particularly useful in remote sensing applications. The device is insensitive to voltage drops over long lines due to its high-impedance current output. Any well insulated twisted pair is sufficient for operation hundreds of feet from the receiving circuitry. The output characteristics also make the AD590 easy to multiplex: the current can be switched by a CMOS multiplexer or the supply voltage can be switched by a logic gate output.

Pinout

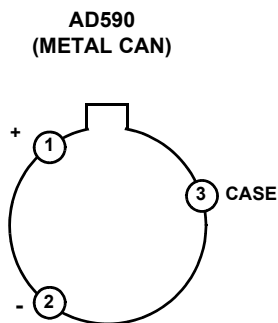

Functional Diagram

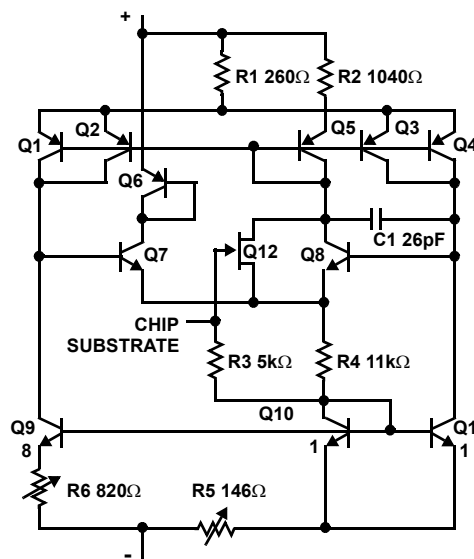

Absolute Maximum Ratings $T_A = 25^{\circ}\text{C}$

Supply Forward Voltage (V+ to V-) +44V
 Supply Reverse Voltage (V+ to V-) -20V
 Breakdown Voltage (Case to V+ to V-) $\pm 200\text{V}$
 Rated Performance Temperature Range TO-52 -55°C to 150°C

Operating Conditions

Temperature Range -55°C to 150°C

CAUTION: Stresses above those listed in "Absolute Maximum Ratings" may cause permanent damage to the device. This is a stress only rating and operation of the device at these or any other conditions above those indicated in the operational sections of this specification is not implied.

NOTE:

- θ_{JA} is measured with the component mounted on an evaluation PC board in free air.

Thermal Information

Thermal Resistance (Typical, Note 1) θ_{JA} ($^{\circ}\text{C}/\text{W}$) θ_{JC} ($^{\circ}\text{C}/\text{W}$)
 Metal Can Package 200 120
 Maximum Junction Temperature (Metal Can Package) 175°C
 Maximum Storage Temperature Range -65°C to 150°C
 Maximum Lead Temperature (Soldering 10s) 300°C

Electrical Specifications Typical Values at $T_A = 25^{\circ}\text{C}$, $V_+ = 5\text{V}$, Unless Otherwise Specified

PARAMETER	TEST CONDITIONS	AD590I	AD590J	UNITS			
Nominal Output Current at 25°C (298.2°K)		298.2	298.2	μA			
Nominal Temperature Coefficient		1.0	1.0	$\mu\text{A}/^{\circ}\text{K}$			
Calibration Error at 25°C	Notes 1, 5	± 10.0 Max	± 5.0 Max	$^{\circ}\text{C}$			
Absolute Error	-55°C to 150°C , Note 7	± 20.0 Max	± 10.0 Max	$^{\circ}\text{C}$			
Without External Calibration Adjustment							
With External Calibration Adjustment		± 5.8 Max	± 3.0 Max	$^{\circ}\text{C}$			
Non-Linearity	Note 6	± 3.0 Max	± 1.5 Max	$^{\circ}\text{C}$			
Repeatability	Notes 2, 6	± 0.1 Max	± 0.1 Max	$^{\circ}\text{C}$			
Long Term Drift	Notes 3, 6	± 0.1 Max	± 0.1 Max	$^{\circ}\text{C}/\text{Month}$			
Current Noise		40	40	$\text{pA}/\sqrt{\text{Hz}}$			
Power Supply Rejection							
+4V < V+ < +5V					0.5	0.5	$\mu\text{A}/\text{V}$
+5V < V+ < +15V					0.2	0.2	$\mu\text{A}/\text{V}$
+15V < V+ < +30V		0.1	0.1	$\mu\text{A}/\text{V}$			
Case Isolation to Either Lead		10^{10}	10^{10}	Ω			
Effective Shunt Capacitance		100	100	pF			
Electrical Turn-On Time	Note 1	20	20	μs			
Reverse Bias Leakage Current	Note 4	10	10	pA			
Power Supply Range		+4 to +30	+4 to +30	V			

NOTES:

- Does not include self heating effects.
- Maximum deviation between 25°C reading after temperature cycling between -55°C and 150°C .
- Conditions constant +5V, constant 125°C .
- Leakage current doubles every 10°C .
- Mechanical strain on package may disturb calibration of device.
- Guaranteed but not tested.
- -55°C Guaranteed by testing at 25°C and 150°C .

Trimming Out Errors

The ideal graph of current versus temperature for the AD590 is a straight line, but as Figure 1 shows, the actual shape is slightly different. Since the sensor is limited to the range of -55°C to 150°C, it is possible to optimize the accuracy by trimming. Trimming also permits extracting maximum performance from the lower-cost sensors.

The circuit of Figure 2 trims the slope of the AD590 output. The effect of this is shown in Figure 3.

The circuit of Figure 4 trims both the slope and the offset. This is shown in Figure 5. The diagrams are exaggerated to show effects, but it should be clear that these trims can be used to minimize errors over the whole range, or over any selected part of the range. In fact, it is possible to adjust the I-grade device to give less than 0.1°C error over the range 0°C to 90°C and less than 0.05°C error from 25°C to 60°C.

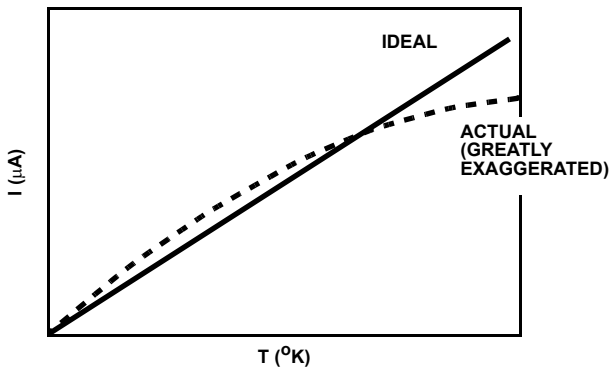

FIGURE 1. TRIMMING OUT ERRORS

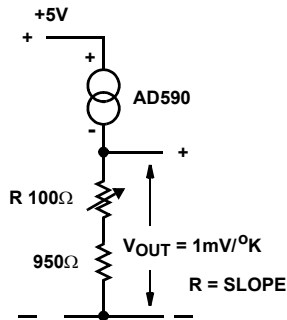

FIGURE 2. SLOPE TRIMMING

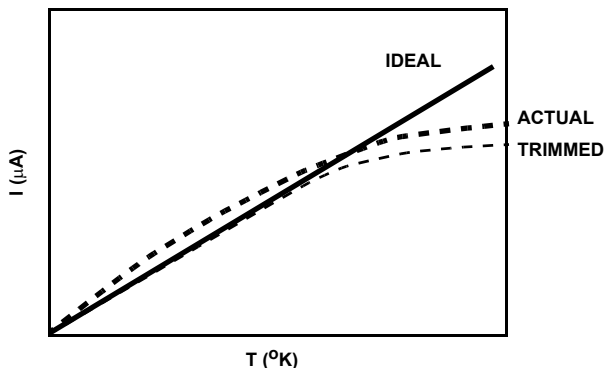

FIGURE 3. EFFECT OF SLOPE TRIM

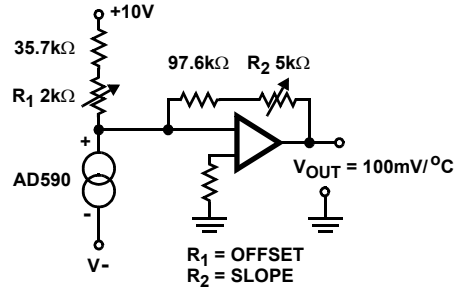

FIGURE 4. SLOPE AND OFFSET TRIMMING

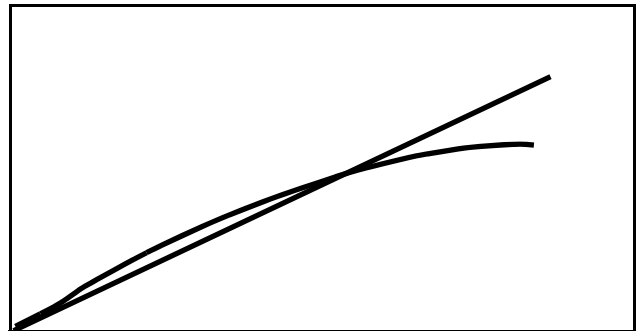

FIGURE 5A. UNTRIMMED

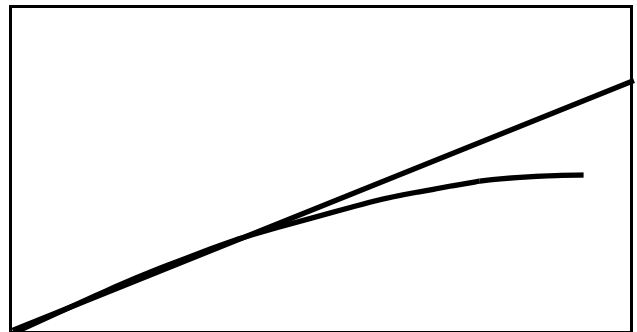

FIGURE 5B. TRIM ONE: OFFSET

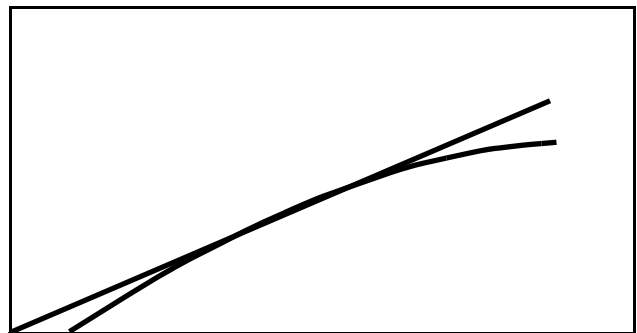

FIGURE 5C. TRIM TWO: SLOPE

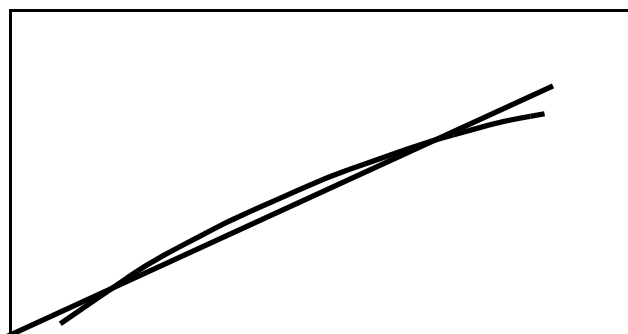

FIGURE 5D. TRIM THREE: OFFSET AGAIN

FIGURE 5. EFFECT OF SLOPE AND OFFSET TRIMMING

Accuracy

Maximum errors over limited temperature spans, with $V_S = +5V$, are listed by device grade in the following tables. The tables reflect the worst-case linearities, which invariably occur at the extremities of the specified temperature range. The trimming conditions for the data in the tables are shown in Figure 2 and Figure 4.

All errors listed in the tables are $\pm^\circ C$. For example, if $\pm 1^\circ C$ maximum error is required over the $25^\circ C$ to $75^\circ C$ range (i.e., lowest temperature of $25^\circ C$ and span of $50^\circ C$), then the trimming of a J-grade device, using the single-trim circuit (Figure 2), will result in output having the required accuracy over the stated range. An I-grade device with two trims (Figure 4) will have less than $\pm 0.2^\circ C$ error. If the requirement is for less than $\pm 1.4^\circ C$ maximum error, from $-25^\circ C$ to $75^\circ C$ ($100^\circ C$ span from $-25^\circ C$), it can be satisfied by an I-grade device with two trims.

I Grade Maximum Errors ($^\circ C$)

NUMBER OF TRIMS	TEMPERATURE SPAN ($^\circ C$)	LOWEST TEMPERATURE IN SPAN ($\times^\circ C$)							
		-55	-25	0	25	50	75	100	125
None	10	8.4	9.2	10.0	10.8	11.6	12.4	13.2	14.4
None	25	10.0	10.4	11.0	11.8	12.0	13.8	15.0	16.0
None	50	13.0	13.0	12.8	13.8	14.6	16.4	18.0	-
None	100	15.2	16.0	16.6	17.4	18.8	-	-	-
None	150	18.4	19.0	19.2	-	-	-	-	-
None	205	20.0	-	-	-	-	-	-	-
One	10	0.6	0.4	0.4	0.4	0.4	0.4	0.4	0.6
One	25	1.8	1.2	1.0	1.0	1.0	1.2	1.6	1.8
One	50	3.8	3.0	2.0	2.0	2.0	3.0	3.8	-
One	100	4.8	4.5	4.2	4.2	5.0	-	-	-
One	150	5.5	4.8	5.5	-	-	-	-	-
One	205	5.8	-	-	-	-	-	-	-
Two	10	0.3	0.2	0.1	(Note 9)	(Note 9)	0.1	0.2	0.3
Two	25	0.5	0.3	0.2	(Note 9)	0.1	0.2	0.3	0.5
Two	50	1.2	0.6	0.4	0.2	0.2	0.3	0.7	-
Two	100	1.8	1.4	1.0	2.0	2.5	-	-	-
Two	150	2.6	2.0	2.8	-	-	-	-	-
Two	205	3.0	-	-	-	-	-	-	-

NOTE:

9. Less than $\pm 0.05^\circ C$.

J Grade Maximum Errors (°C)

NUMBER OF TRIMS	TEMPERATURE SPAN (°C)	LOWEST TEMPERATURE IN SPAN (×°C)							
		-55	-25	0	25	50	75	100	125
None	10	4.2	4.6	5.0	5.4	5.8	6.2	6.6	7.2
None	25	5.0	5.2	5.5	5.9	6.0	6.9	7.5	8.0
None	50	6.5	6.5	6.4	6.9	7.3	8.2	9.0	-
None	100	7.7	8.0	8.3	8.7	9.4	-	-	-
None	150	9.2	9.5	9.6	-	-	-	-	-
None	205	10.0	-	-	-	-	-	-	-
One	10	0.3	0.2	0.2	0.2	0.2	0.2	0.2	0.3
One	25	0.9	0.6	0.5	0.5	0.5	0.6	0.8	0.9
One	50	1.9	1.5	1.0	1.0	1.0	1.5	1.9	-
One	100	2.3	2.2	2.0	2.0	2.3	-	-	-
One	150	2.5	2.4	2.5	-	-	-	-	-
One	205	3.0	-	-	-	-	-	-	-
Two	10	0.1	(Note 10)	(Note 10)	(Note 10)	(Note 10)	(Note 10)	(Note 10)	0.1
Two	25	0.2	0.1	(Note 10)	(Note 10)	(Note 10)	(Note 10)	0.1	0.2
Two	50	0.4	0.2	0.1	(Note 10)	(Note 10)	0.1	0.2	(Note 10)
Two	100	0.7	0.5	0.3	0.7	1.0	-	-	-
Two	150	1.0	0.7	1.2	-	-	-	-	-
Two	205	1.6	-	-	-	-	-	-	-

NOTE:

10. Less than ±0.05°C.

NOTES

- Maximum errors over all ranges are guaranteed based on the known behavior characteristic of the AD590.
- For one-trim accuracy specifications, the 205°C span is assumed to be trimmed at 25°C; for all other spans, it is assumed that the device is trimmed at the midpoint.
- For the 205°C span, it is assumed that the two-trim temperatures are in the vicinity of 0°C and 140°C; for all other spans, the specified trims are at the endpoints.
- In precision applications, the actual errors encountered are usually dependent upon sources of error which are often overlooked in error budgets. These typically include:
 - Trim error in the calibration technique used
 - Repeatability error
 - Long term drift errors

Trim Error is usually the largest error source. This error arises from such causes as poor thermal coupling between the device to be calibrated and the reference sensor; reference sensor errors; lack of adequate time for the device being calibrated to settle to the final temperature; radically different thermal resistances between the case and the surroundings ($R_{\theta CA}$) when trimming and when applying the device.

Repeatability Errors arise from a strain hysteresis of the package. The magnitude of this error is solely a function of the magnitude of the temperature span over which the device is used. For example, thermal shocks between 0°C and 100°C involve extremely low hysteresis and result in repeatability errors of less than ±0.05°C. When the thermal-shock excursion is widened to -55°C to 150°C, the device will typically exhibit a repeatability error of ±0.05°C (±0.10 guaranteed maximum).

Long Term Drift Errors are related to the average operating temperature and the magnitude of the thermal-shocks experienced by the device. Extended use of the AD590 at temperatures above 100°C typically results in long-term drift of ±0.03°C per month; the guaranteed maximum is ±0.10°C per month. Continuous operation at temperatures below 100°C induces no measurable drifts in the device. Besides the effects of operating temperature, the severity of thermal shocks incurred will also affect absolute stability. For thermal-shock excursions less than 100°C, the drift is difficult to measure (<0.03°C). However, for 200°C excursions, the device may drift by as much as ±0.10°C after twenty such shocks. If severe, quick shocks are necessary in the application of the device, realistic simulated life tests are recommended for a thorough evaluation of the error introduced by such shocks.

Typical Applications

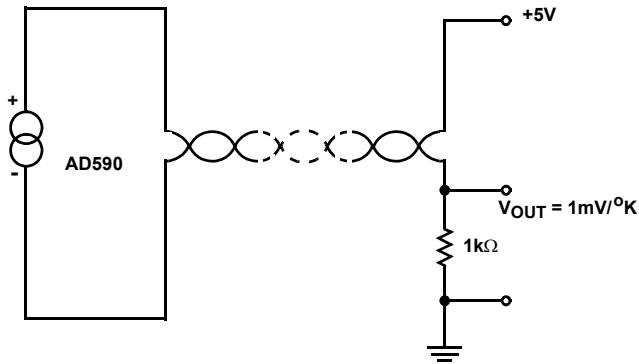

FIGURE 6A.

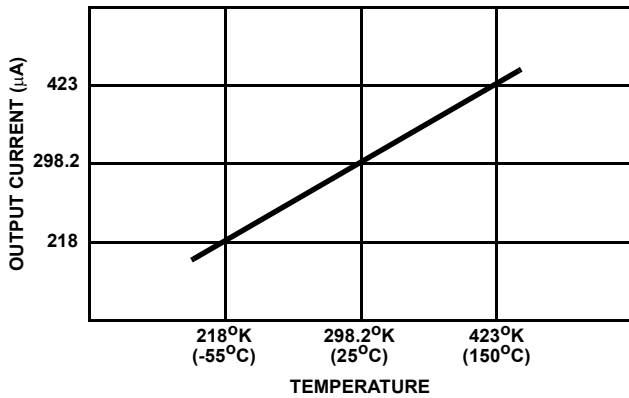

FIGURE 6B.

FIGURE 6. SIMPLE CONNECTION. OUTPUT IS PROPORTIONAL TO ABSOLUTE TEMPERATURE

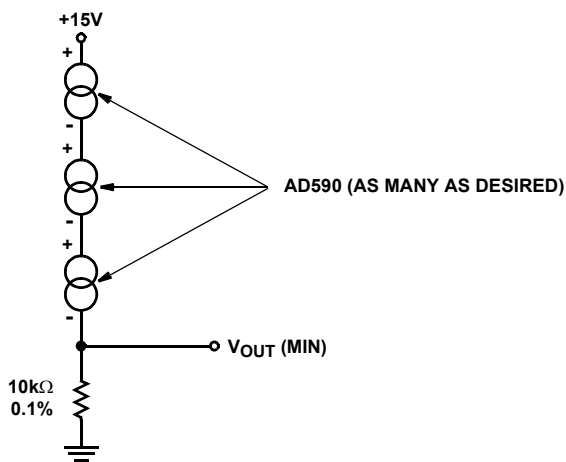

FIGURE 7. LOWEST TEMPERATURE SENSING SCHEME. AVAILABLE CURRENT IS THAT OF THE "COLDEST" SENSOR

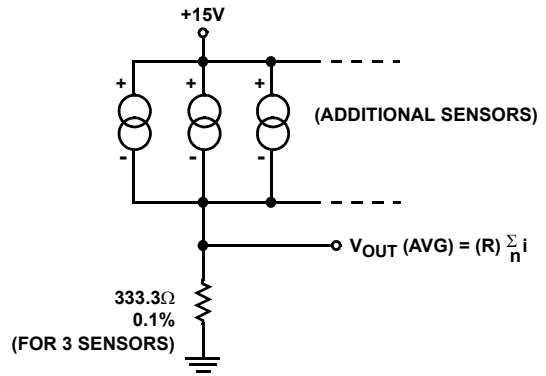

FIGURE 8. AVERAGE TEMPERATURE SENSING SCHEME

The sum of the AD590 currents appears across R, which is chosen by the formula: $R = \frac{10k\Omega}{n}$,

where n = the number of sensors. See Figure 8.

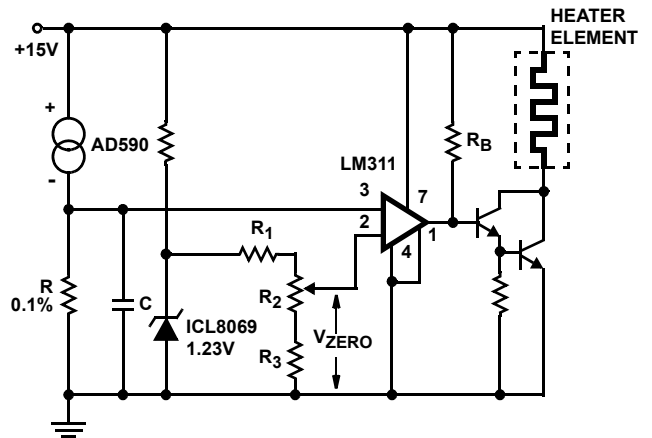

FIGURE 9. SINGLE SETPOINT TEMPERATURE CONTROLLER

The AD590 produces a temperature-dependent voltage across R (C is for filtering noise). Setting R₂ produces a scale-zero voltage. For the celsius scale, make R = 1kΩ and V_{ZERO} = 0.273V. For Fahrenheit, R = 1.8kΩ and V_{ZERO} = 0.460V. See Figure 9.

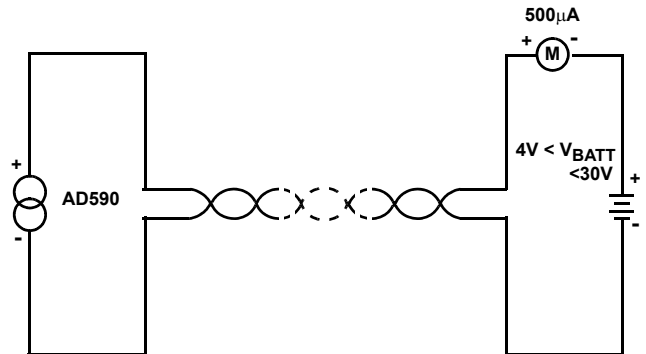

FIGURE 10. SIMPLEST THERMOMETER

Meter displays current output directly in degrees Kelvin. using the AD590J, sensor output is within ±10 degrees over the entire range. See Figure 10.

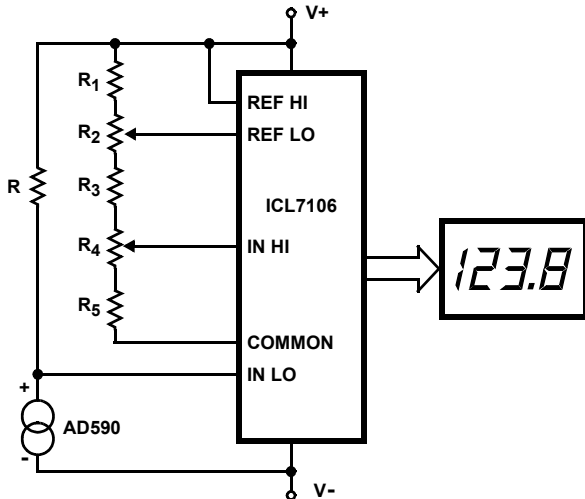

FIGURE 11. BASIC DIGITAL THERMOMETER, CELSIUS AND FAHRENHEIT SCALES

	R	R ₁	R ₂	R ₃	R ₄	R ₅
°F	9.00	4.02	2.0	12.4	10.0	0
°C	5.00	4.02	2.0	5.11	5.0	11.8

5

$$\sum_{n=1}^5 R_n = 28\text{k}\Omega \text{ nominal}$$

ALL values are in kΩ.

The ICL7106 has a V_{IN} span of $\pm 2.0\text{V}$ and a V_{CM} range of $(V_+ - 0.5\text{V})$ to $(V_- + 1\text{V})$. R is scaled to bring each range within V_{CM} while not exceeding V_{IN} . V_{REF} for both scales is 500mV maximum reading on the celsius range 199.9°C limited by the (short-term) maximum allowable sensor temperature. Maximum reading on the fahrenheit range is 199.9°F (93.3°C) limited by the number of display digits. See Figure 11 and notes below.

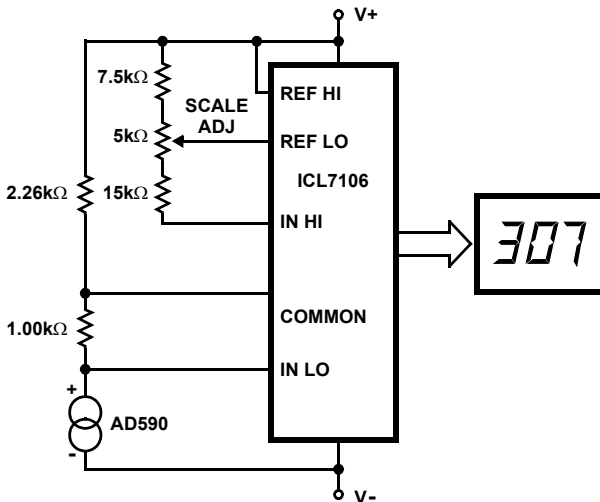

FIGURE 12. BASIC DIGITAL THERMOMETER, KELVIN SCALE

The Kelvin scale version reads from 0 to 1999°K theoretically, and from 223°K to 473°K actually. The 2.26kΩ resistor brings the input within the ICL7106 V_{CM} range: 2 general-purpose silicon diodes or an LED may be substituted. See Figure 12 and notes below.

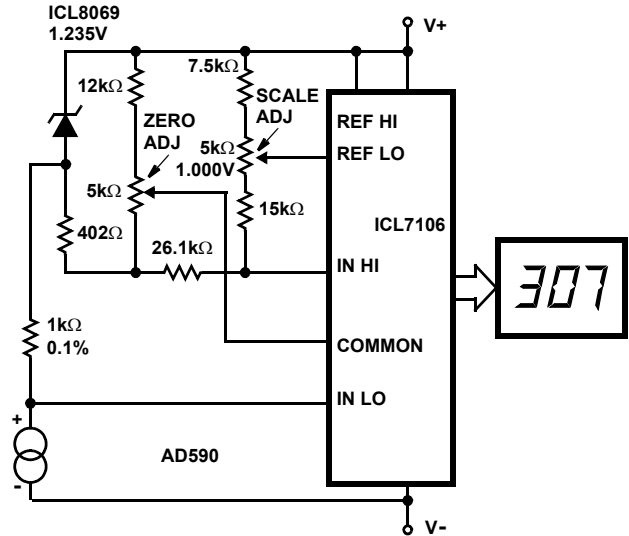

FIGURE 13. BASIC DIGITAL THERMOMETER, KELVIN SCALE WITH ZERO ADJUST

This circuit allows “zero adjustment” as well as slope adjustment. the ICL8069 brings the input within the common-mode range, while the 5kΩ pots trim any offset at 218°K (-55°C), and set the scale factor. See Figure 13 and notes below.

Notes for Figure 11, Figure 12 and Figure 13

Since all 3 scales have narrow V_{IN} spans, some optimization of ICL7106 components can be made to lower noise and preserve CMR. The table below shows the suggested values. Similar scaling can be used with the ICL7126 and ICL7136.

SCALE	V_{IN} RANGE (V)	R_{INT} (kΩ)	C_{AZ} (μF)
K	0.223 to 0.473	220	0.47
C	-0.25 to +1.0	220	0.1
F	-0.29 to +0.996	220	0.1

For all:
 $C_{REF} = 0.1\mu\text{F}$
 $C_{INT} = 0.22\mu\text{F}$
 $C_{OSC} = 100\text{pF}$
 $R_{OSC} = 100\text{k}\Omega$

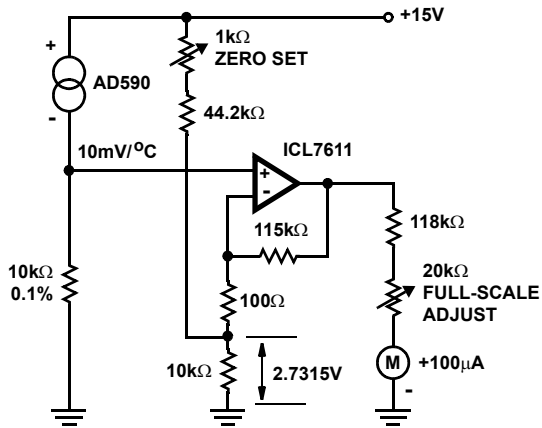

FIGURE 14. CENTIGRADE THERMOMETER (0°C-100°C)

The ultra-low bias current of the ICL7611 allows the use of large value gain resistors, keeping meter current error under 1/2%, and therefore saving the expense of an extra meter driving amplifier. See Figure 14.

The 50kΩ pot trims offsets in the devices whether internal or external, so it can be used to set the size of the difference interval. this also makes it useful for liquid level detection (where there will be a measurable temperature difference). See Figure 15.

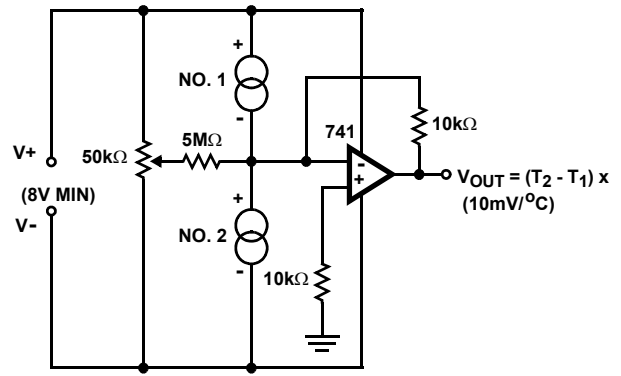

FIGURE 15. DIFFERENTIAL THERMOMETER

The reference junction(s) should be in close thermal contact with the AD590 case. V+ must be at least 4V, while ICL8069 current should be set at 1mA - 2mA. Calibration does not require shorting or removal of the thermocouple: set R₁ for V₂ = 10.98mV. If very precise measurements are needed, adjust R₂ to the exact Seebeck coefficient for the thermocouple used (measured or from table) note V₁, and set R₁ to buck out this voltage (i.e., set V₂ = V₁). For other thermocouple types, adjust values to the appropriate Seebeck coefficient. See Figure 16.

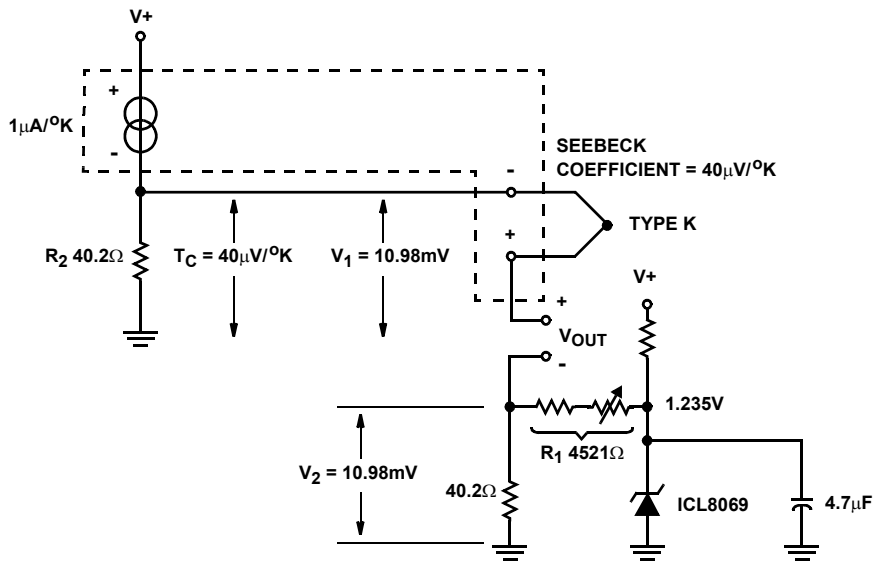

FIGURE 16. COLD JUNCTION COMPENSATION FOR TYPE K THERMOCOUPLE

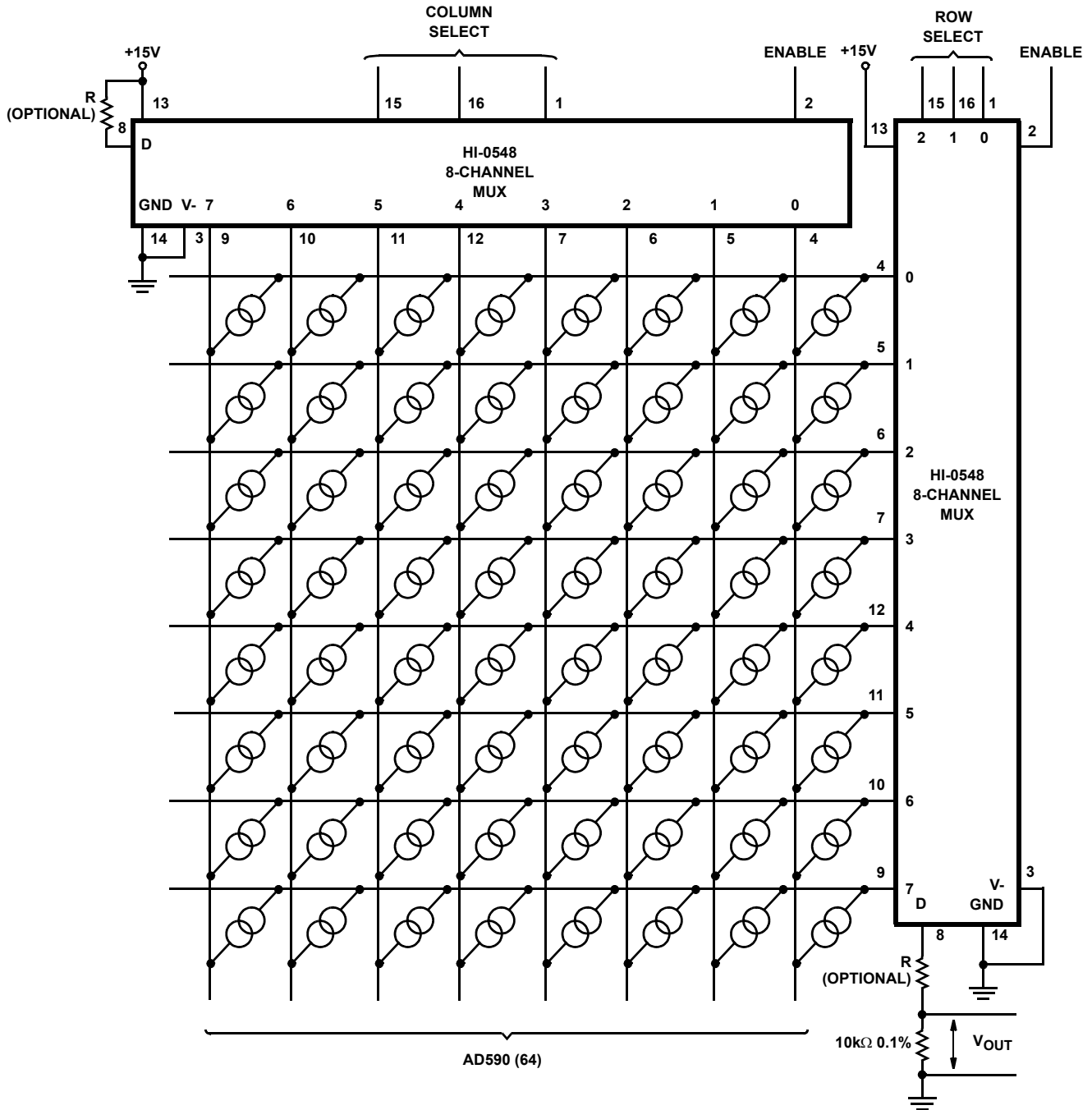

FIGURE 17. MULTIPLEXING SENSORS

If shorted sensors are possible, a series resistor in series with the D line will limit the current (shown as R, above: only one is needed). A six-bit digital word will select one of 64 sensors.

Die Characteristics

DIE DIMENSIONS:

37 mils x 58 mils x 14 mils ± 1 mil

METALLIZATION:

Type: Aluminum 100%

Thickness: $15\text{k}\text{\AA} \pm 1\text{k}\text{\AA}$

PASSIVATION:

Type: PSG/Nitride

PSG Thickness: $7\text{k}\text{\AA} \pm 1.4\text{k}\text{\AA}$

Nitride Thickness: $8\text{k}\text{\AA} \pm 1.2\text{k}\text{\AA}$

Metallization Mask Layout

AD590

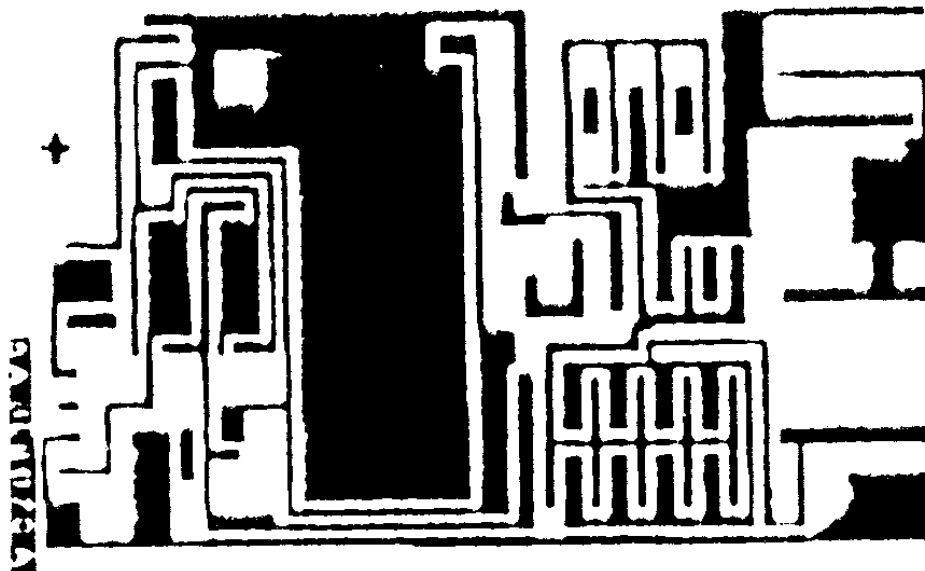

© Copyright Intersil Americas LLC 2002. All Rights Reserved.

All trademarks and registered trademarks are the property of their respective owners.

For additional products, see www.intersil.com/en/products.html

Intersil products are manufactured, assembled and tested utilizing ISO9001 quality systems as noted in the quality certifications found at www.intersil.com/en/support/qualandreliability.html

Intersil products are sold by description only. Intersil may modify the circuit design and/or specifications of products at any time without notice, provided that such modification does not, in Intersil's sole judgment, affect the form, fit or function of the product. Accordingly, the reader is cautioned to verify that datasheets are current before placing orders. Information furnished by Intersil is believed to be accurate and reliable. However, no responsibility is assumed by Intersil or its subsidiaries for its use; nor for any infringements of patents or other rights of third parties which may result from its use. No license is granted by implication or otherwise under any patent or patent rights of Intersil or its subsidiaries.

For information regarding Intersil Corporation and its products, see www.intersil.com