



# Complete Quad, 16-Bit, High Accuracy, Serial Input, Bipolar Voltage Output DAC

## AD5764R

### FEATURES

- Complete quad, 16-bit digital-to-analog converter (DAC)
- Programmable output range:  $\pm 10$  V,  $\pm 10.2564$  V, or  $\pm 10.5263$  V
- $\pm 1$  LSB maximum INL error,  $\pm 1$  LSB maximum DNL error
- Low noise: 60 nV/ $\sqrt{\text{Hz}}$
- Settling time: 10  $\mu\text{s}$  maximum
- Integrated reference buffers
- Internal reference: 10 ppm/ $^{\circ}\text{C}$  maximum
- On-chip die temperature sensor
- Output control during power-up/brownout
- Programmable short-circuit protection
- Simultaneous updating via  $\overline{\text{LDAC}}$
- Asynchronous  $\overline{\text{CLR}}$  to zero code
- Digital offset and gain adjust
- Logic output control pins
- DSP-/microcontroller-compatible serial interface
- Temperature range:  $-40^{\circ}\text{C}$  to  $+85^{\circ}\text{C}$
- iCMOS process technology

### APPLICATIONS

- Industrial automation
- Open-loop/closed-loop servo control
- Process control
- Data acquisition systems
- Automatic test equipment
- Automotive test and measurement
- High accuracy instrumentation

### GENERAL DESCRIPTION

The AD5764R is a quad, 16-bit, serial input, bipolar voltage output DAC that operates from supply voltages of  $\pm 11.4$  V to  $\pm 16.5$  V. Nominal full-scale output range is  $\pm 10$  V. The AD5764R provides integrated output amplifiers, reference buffers, and proprietary power-up/power-down control circuitry. The part also features a digital I/O port, programmed via the serial interface, and an analog temperature sensor. The part incorporates digital offset and gain adjust registers per channel.

The AD5764R is a high performance converter that provides guaranteed monotonicity, integral nonlinearity (INL) of  $\pm 1$  LSB, low noise, and 10  $\mu\text{s}$  settling time. The AD5764R includes an on-chip 5 V reference with a reference temperature coefficient of 10 ppm/ $^{\circ}\text{C}$  maximum. During power-up when the supply voltages are changing,  $\text{VOUTx}$  is clamped to 0 V via a low impedance path.

The AD5764R is based on the iCMOS<sup>®</sup> technology platform, which is designed for analog systems designers within industrial/instrumentation equipment OEMs who need high performance ICs at higher voltage levels. iCMOS enables the development of analog ICs capable of 30 V and operation at  $\pm 15$  V supplies, while allowing reductions in power consumption and package size, coupled with increased ac and dc performance.

The AD5764R uses a serial interface that operates at clock rates of up to 30 MHz and is compatible with DSP and microcontroller interface standards. Double buffering allows the simultaneous updating of all DACs. The input coding is programmable to either twos complement or offset binary formats. The asynchronous clear function clears all DAC registers to either bipolar zero or zero scale, depending on the coding used. The AD5764R is ideal for both closed-loop servo control and open-loop control applications. The AD5764R is available in a 32-lead TQFP and offers guaranteed specifications over the  $-40^{\circ}\text{C}$  to  $+85^{\circ}\text{C}$  industrial temperature range (see Figure 1 for the functional block diagram).

#### Rev. 0

Information furnished by Analog Devices is believed to be accurate and reliable. However, no responsibility is assumed by Analog Devices for its use, nor for any infringements of patents or other rights of third parties that may result from its use. Specifications subject to change without notice. No license is granted by implication or otherwise under any patent or patent rights of Analog Devices. Trademarks and registered trademarks are the property of their respective owners.

One Technology Way, P.O. Box 9106, Norwood, MA 02062-9106, U.S.A.  
Tel: 781.329.4700 [www.analog.com](http://www.analog.com)  
Fax: 781.461.3113 ©2008 Analog Devices, Inc. All rights reserved.

**TABLE OF CONTENTS**

Features .....	1	Function Register .....	24
Applications.....	1	Data Register.....	25
General Description.....	1	Coarse Gain Register .....	25
Revision History .....	2	Fine Gain Register .....	25
Functional Block Diagram .....	3	Offset Register .....	26
Specifications.....	4	Offset and Gain Adjustment Worked Example.....	26
AC Performance Characteristics .....	6	Design Features.....	27
Timing Characteristics .....	7	Analog Output Control .....	27
Absolute Maximum Ratings.....	10	Digital Offset and Gain Control.....	27
Thermal Resistance .....	10	Programmable Short-Circuit Protection .....	27
ESD Caution.....	10	Digital I/O Port.....	27
Pin Configuration and Function Descriptions.....	11	Die Temperature Sensor .....	27
Typical Performance Characteristics .....	13	Local Ground Offset Adjust.....	27
Terminology .....	19	Applications Information .....	28
Theory of Operation .....	21	Typical Operating Circuit .....	28
DAC Architecture.....	21	Layout Guidelines.....	30
Reference Buffers.....	21	Galvanically Isolated Interface .....	30
Serial Interface .....	21	Microprocessor Interfacing.....	30
Simultaneous Updating via $\overline{\text{LDAC}}$ .....	22	Evaluation Board .....	31
Transfer Function .....	23	Outline Dimensions .....	32
Asynchronous Clear ( $\overline{\text{CLR}}$ ).....	23	Ordering Guide .....	32
Registers.....	24		

**REVISION HISTORY****10/08—Revision 0: Initial Version**

# FUNCTIONAL BLOCK DIAGRAM

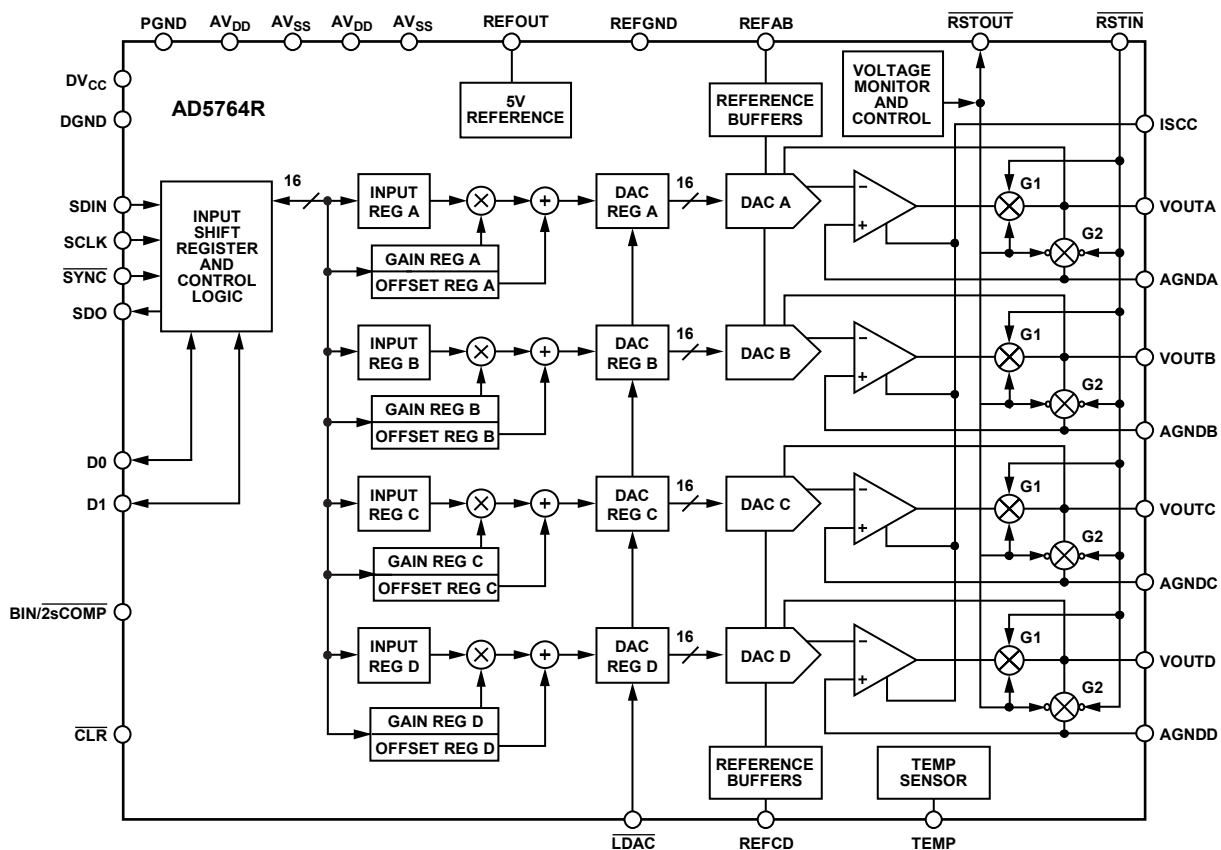

Figure 1.

061064-001

# AD5764R

## SPECIFICATIONS

$AV_{DD} = 11.4\text{ V to }16.5\text{ V}$ ,  $AV_{SS} = -11.4\text{ V to }-16.5\text{ V}$ ,  $AGND = DGND = REFGND = PGND = 0\text{ V}$ ;  $REFAB = REFCD = 5\text{ V external}$ ;  $DV_{CC} = 2.7\text{ V to }5.25\text{ V}$ ,  $R_{LOAD} = 10\text{ k}\Omega$ ,  $C_L = 200\text{ pF}$ . All specifications  $T_{MIN}$  to  $T_{MAX}$ , unless otherwise noted.

**Table 1.**

Parameter	B Grade <sup>1</sup>	C Grade <sup>1</sup>	Unit	Test Conditions/Comments
<b>ACCURACY</b>				
Resolution	16	16	Bits	Outputs unloaded
Relative Accuracy (INL)	±2	±1	LSB max	
Differential Nonlinearity (DNL)	±1	±1	LSB max	
Bipolar Zero Error	±2	±2	mV max	Guaranteed monotonic 25°C; error at other temperatures obtained using bipolar zero tempco
Bipolar Zero Tempco <sup>2</sup>	±3	±3	mV max	
Zero-Scale Error	±2	±2	ppm FSR/°C max	25°C; error at other temperatures obtained using zero-scale tempco
Zero-Scale Tempco <sup>2</sup>	±2.5	±2.5	mV max	
Gain Error	±2	±2	ppm FSR/°C max	
Gain Tempco <sup>2</sup>	±0.02	±0.02	% FSR max	
DC Crosstalk <sup>2</sup>	±2	±2	ppm FSR/°C max	
DC Crosstalk <sup>2</sup>	0.5	0.5	LSB max	
<b>REFERENCE INPUT/OUTPUT</b>				
Reference Input <sup>2</sup>				
Reference Input Voltage	5	5	V nominal	±1% for specified performance
DC Input Impedance	1	1	MΩ min	Typically 100 MΩ
Input Current	±10	±10	μA max	Typically ±30 nA
Reference Range	1/7	1/7	V min/V max	
Reference Output				
Output Voltage	4.995/5.005	4.995/5.005	V min/V max	At 25°C, $AV_{DD}/AV_{SS} = \pm 13.5\text{ V}$
Reference Tempco <sup>2</sup>	±10	±10	ppm/°C max	Typically 1.7ppm/°C
$R_{LOAD}$ <sup>2</sup>	1	1	MΩ min	
Power Supply Sensitivity <sup>2</sup>	300	300	μV/V typ	
Output Noise <sup>2</sup>	18	18	μV p-p typ	0.1 Hz to 10 Hz
Noise Spectral Density <sup>2</sup>	75	75	nV/√Hz typ	At 10 kHz
Output Voltage Drift vs. Time <sup>2</sup>	±40	±40	ppm/500 hr typ	
	±50	±50	ppm/1000 hr typ	
Thermal Hysteresis <sup>2</sup>	70	70	ppm typ	First temperature cycle
	30	30	ppm typ	Subsequent temperature cycles
<b>OUTPUT CHARACTERISTICS<sup>2</sup></b>				
Output Voltage Range <sup>3</sup>	±10.5263	±10.5263	V min/V max	$AV_{DD}/AV_{SS} = \pm 11.4\text{ V}$ , $REFIN = 5\text{ V}$
	±14	±14	V min/V max	$AV_{DD}/AV_{SS} = \pm 16.5\text{ V}$ , $REFIN = 7\text{ V}$
Output Voltage Drift vs. Time	±13	±13	ppm FSR/500 hr typ	
	±15	±15	ppm FSR/1000 hr typ	
Short-Circuit Current	10	10	mA typ	$R_{ISCC} = 6\text{ k}\Omega$ , see Figure 31
Load Current	±1	±1	mA max	For specified performance
Capacitive Load Stability				
$R_{LOAD} = \infty$	200	200	pF max	
$R_{LOAD} = 10\text{ k}\Omega$	1000	1000	pF max	
DC Output Impedance	0.3	0.3	Ω max	

Parameter	B Grade <sup>1</sup>	C Grade <sup>1</sup>	Unit	Test Conditions/Comments
<b>DIGITAL INPUTS<sup>2</sup></b>				$DV_{CC} = 2.7\text{ V to }5.25\text{ V}$
Input High Voltage, $V_{IH}$	2.4	2.4	V min	
Input Low Voltage, $V_{IL}$	0.8	0.8	V max	
Input Current	$\pm 1.2$	$\pm 1.2$	$\mu\text{A max}$	Per pin
Pin Capacitance	10	10	pF max	Per pin
<b>DIGITAL OUTPUTS (D0, D1, SDO)<sup>2</sup></b>				
Output Low Voltage	0.4	0.4	V max	$DV_{CC} = 5\text{ V} \pm 5\%$ , sinking 200 $\mu\text{A}$
Output High Voltage	$DV_{CC} - 1$	$DV_{CC} - 1$	V min	$DV_{CC} = 5\text{ V} \pm 5\%$ , sourcing 200 $\mu\text{A}$
Output Low Voltage	0.4	0.4	V max	$DV_{CC} = 2.7\text{ V to }3.6\text{ V}$ , sinking 200 $\mu\text{A}$
Output High Voltage	$DV_{CC} - 0.5$	$DV_{CC} - 0.5$	V min	$DV_{CC} = 2.7\text{ V to }3.6\text{ V}$ , sourcing 200 $\mu\text{A}$
High Impedance Leakage Current	$\pm 1$	$\pm 1$	$\mu\text{A max}$	SDO only
High Impedance Output Capacitance	5	5	pF typ	SDO only
<b>DIE TEMPERATURE SENSOR<sup>2</sup></b>				
Output Voltage at 25°C	1.47	1.47	V typ	Die temperature
Output Voltage Scale Factor	5	5	mV/°C typ	
Output Voltage Range	1.175/1.9	1.175/1.9	V min/V max	-40°C to +105°C
Output Load Current	200	200	$\mu\text{A max}$	Current source only
Power-On Time	10	10	ms typ	
<b>POWER REQUIREMENTS</b>				
$AV_{DD}/AV_{SS}$	11.4/16.5	11.4/16.5	V min/V max	
$DV_{CC}$	2.7/5.25	2.7/5.25	V min/V max	
Power Supply Sensitivity <sup>2</sup>				
$\Delta V_{OUT}/\Delta V_{DD}$	-85	-85	dB typ	
$AI_{DD}$	3.55	3.55	mA/channel max	Outputs unloaded
$AI_{SS}$	2.8	2.8	mA/channel max	Outputs unloaded
$DI_{CC}$	1.2	1.2	mA max	$V_{IH} = DV_{CC}$ , $V_{IL} = DGND$ , 750 $\mu\text{A typ}$
Power Dissipation	275	275	mW typ	$\pm 12\text{ V operation output unloaded}$

<sup>1</sup> Temperature range: -40°C to +85°C; typical at +25°C. Device functionality is guaranteed to +105°C with degraded performance.

<sup>2</sup> Guaranteed by design and characterization; not production tested.

<sup>3</sup> Output amplifier headroom requirement is 1.4 V minimum.

# AD5764R

## AC PERFORMANCE CHARACTERISTICS

$AV_{DD} = 11.4\text{ V to }16.5\text{ V}$ ,  $AV_{SS} = -11.4\text{ V to }-16.5\text{ V}$ ,  $AGND = DGND = REFGND = PGND = 0\text{ V}$ ;  $REFAB = REFCD = 5\text{ V external}$ ;  $DV_{CC} = 2.7\text{ V to }5.25\text{ V}$ ,  $R_{LOAD} = 10\text{ k}\Omega$ ,  $C_L = 200\text{ pF}$ . All specifications  $T_{MIN}$  to  $T_{MAX}$ , unless otherwise noted.

Table 2.

Parameter	B Grade	C Grade	Unit	Test Conditions/Comments
DYNAMIC PERFORMANCE <sup>1</sup>				
Output Voltage Settling Time	8	8	$\mu\text{s typ}$	Full-scale step to $\pm 1$ LSB
	10	10	$\mu\text{s max}$	
	2	2	$\mu\text{s typ}$	
Slew Rate	5	5	$\text{V}/\mu\text{s typ}$	512 LSB step settling
Digital-to-Analog Glitch Energy	8	8	$\text{nV}\cdot\text{sec typ}$	
Glitch Impulse Peak Amplitude	25	25	$\text{mV max}$	
Channel-to-Channel Isolation	80	80	$\text{dB typ}$	
DAC-to-DAC Crosstalk	8	8	$\text{nV}\cdot\text{sec typ}$	
Digital Crosstalk	2	2	$\text{nV}\cdot\text{sec typ}$	
Digital Feedthrough	2	2	$\text{nV}\cdot\text{sec typ}$	Effect of input bus activity on DAC outputs
Output Noise (0.1 Hz to 10 Hz)	0.1	0.1	$\text{LSB p-p typ}$	
Output Noise (0.1 Hz to 100 kHz)	45	45	$\mu\text{V rms max}$	
1/f Corner Frequency	1	1	$\text{kHz typ}$	
Output Noise Spectral Density	60	60	$\text{nV}/\sqrt{\text{Hz typ}}$	Measured at 10 kHz
Complete System Output Noise Spectral Density <sup>2</sup>	80	80	$\text{nV}/\sqrt{\text{Hz typ}}$	Measured at 10 kHz

<sup>1</sup> Guaranteed by design and characterization; not production tested.

<sup>2</sup> Includes noise contributions from integrated reference buffers, a 16-bit DAC, and an output amplifier.

## TIMING CHARACTERISTICS

$AV_{DD} = 11.4\text{ V to }16.5\text{ V}$ ,  $AV_{SS} = -11.4\text{ V to }-16.5\text{ V}$ ,  $AGND = DGND = REFGND = PGND = 0\text{ V}$ ;  $REFAB = REFCD = 5\text{ V external}$ ;  $DV_{CC} = 2.7\text{ V to }5.25\text{ V}$ ,  $R_{LOAD} = 10\text{ k}\Omega$ ,  $C_L = 200\text{ pF}$ . All specifications  $T_{MIN}$  to  $T_{MAX}$ , unless otherwise noted.

**Table 3.**

Parameter <sup>1, 2, 3</sup>	Limit at $T_{MIN}, T_{MAX}$	Unit	Description
$t_1$	33	ns min	SCLK cycle time
$t_2$	13	ns min	SCLK high time
$t_3$	13	ns min	SCLK low time
$t_4$	13	ns min	$\overline{SYNC}$ falling edge to SCLK falling edge setup time
$t_5^4$	13	ns min	24 <sup>th</sup> SCLK falling edge to $\overline{SYNC}$ rising edge
$t_6$	40	ns min	Minimum $\overline{SYNC}$ high time
$t_7$	2	ns min	Data setup time
$t_8$	5	ns min	Data hold time
$t_9$	1.7	$\mu\text{s min}$	$\overline{SYNC}$ rising edge to $\overline{LDAC}$ falling edge (all DACs updated)
	480	ns min	$\overline{SYNC}$ rising edge to $\overline{LDAC}$ falling edge (single DAC updated)
$t_{10}$	10	ns min	$\overline{LDAC}$ pulse width low
$t_{11}$	500	ns max	$\overline{LDAC}$ falling edge to DAC output response time
$t_{12}$	10	$\mu\text{s max}$	DAC output settling time
$t_{13}$	10	ns min	$\overline{CLR}$ pulse width low
$t_{14}$	2	$\mu\text{s max}$	$\overline{CLR}$ pulse activation time
$t_{15}^{5, 6}$	25	ns max	SCLK rising edge to SDO valid
$t_{16}$	13	ns min	$\overline{SYNC}$ rising edge to SCLK falling edge
$t_{17}$	2	$\mu\text{s max}$	$\overline{SYNC}$ rising edge to DAC output response time ( $\overline{LDAC} = 0$ )
$t_{18}$	170	ns min	$\overline{LDAC}$ falling edge to $\overline{SYNC}$ rising edge

<sup>1</sup> Guaranteed by design and characterization; not production tested.

<sup>2</sup> All input signals are specified with  $t_r = t_f = 5\text{ ns}$  (10% to 90% of  $DV_{CC}$ ) and timed from a voltage level of 1.2 V.

<sup>3</sup> See Figure 2, Figure 3, and Figure 4.

<sup>4</sup> Standalone mode only.

<sup>5</sup> Measured with the load circuit of Figure 5.

<sup>6</sup> Daisy-chain mode only.

# AD5764R

## Timing Diagrams

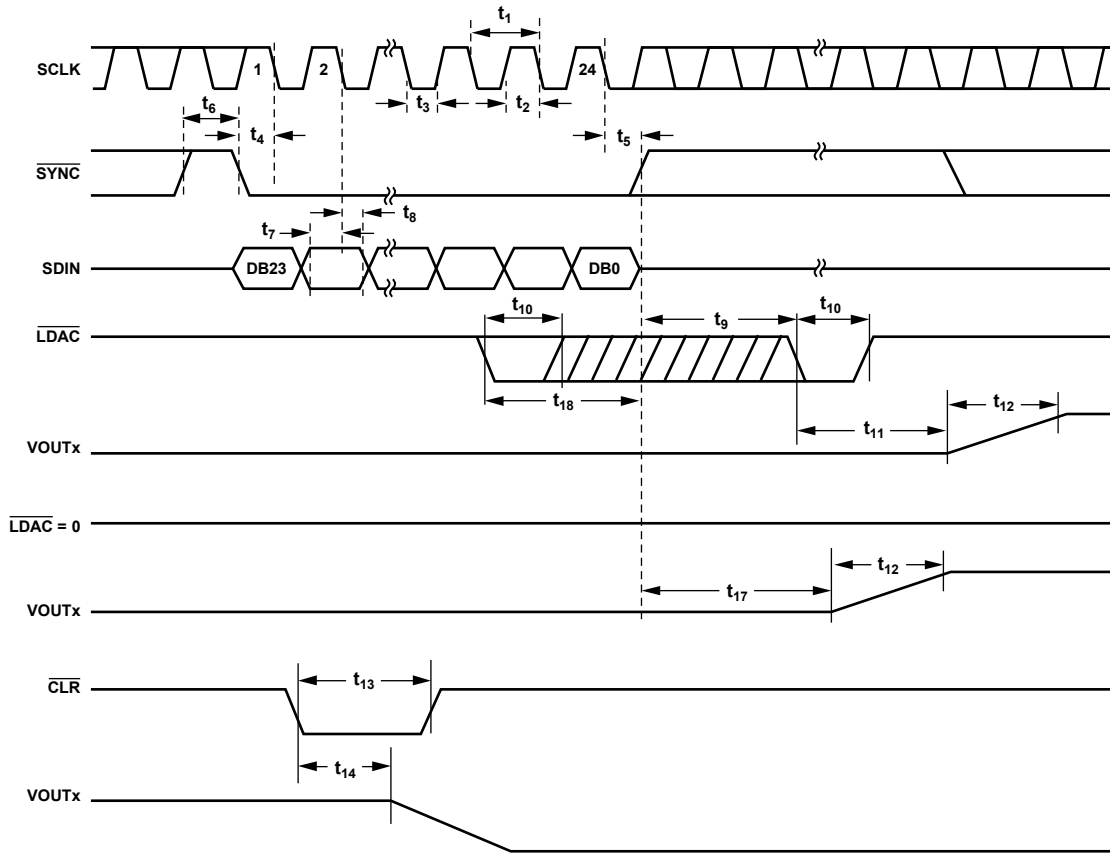

06064-002

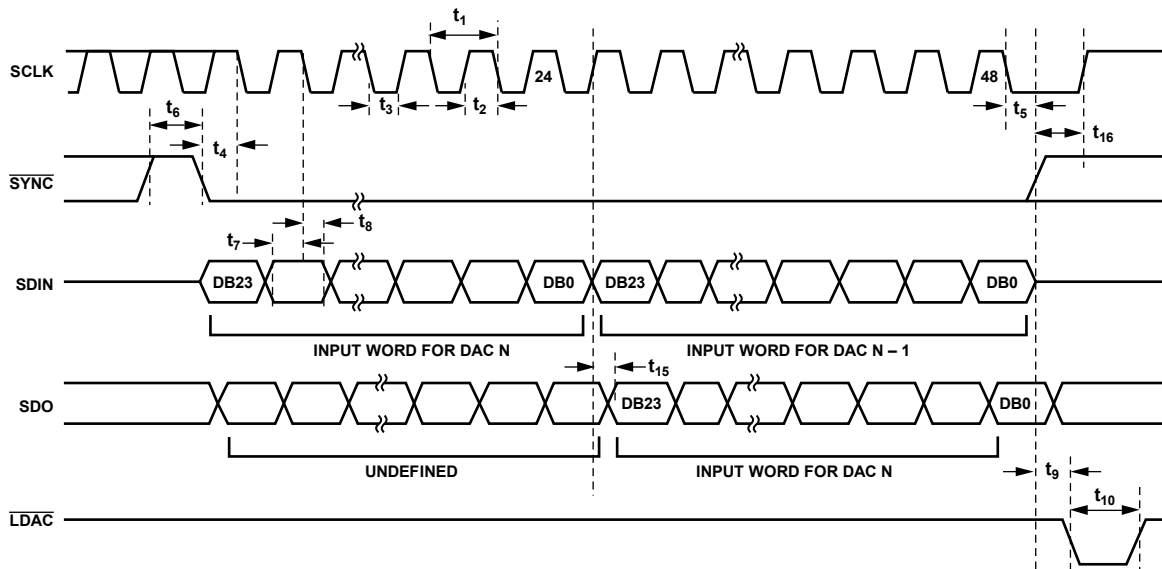

06064-003



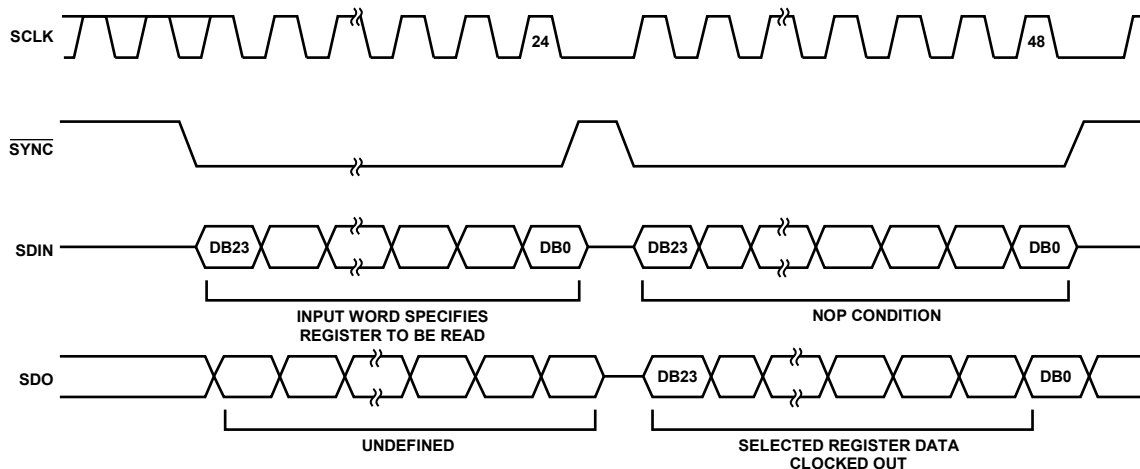

06064-004

Figure 4. Readback Timing Diagram

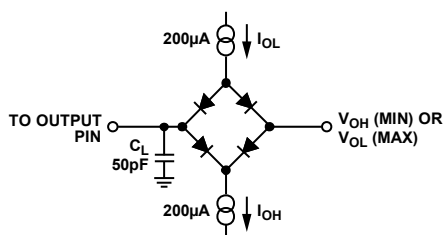

06064-005

Figure 5. Load Circuit for SDO Timing Diagram

## ABSOLUTE MAXIMUM RATINGS

$T_A = 25^\circ\text{C}$ , unless otherwise noted. Transient currents of up to 100 mA do not cause SCR latch-up.

**Table 4.**

Parameter	Rating
$AV_{DD}$ to AGND, DGND	-0.3 V to +17 V
$AV_{SS}$ to AGND, DGND	+0.3 V to -17 V
$DV_{CC}$ to DGND	-0.3 V to +7 V
Digital Inputs to DGND	-0.3 V to ( $DV_{CC} + 0.3$ V) or +7 V, whichever is less
Digital Outputs to DGND	-0.3 V to $DV_{CC} + 0.3$ V
REFIN to AGND, PGND	-0.3 V to $AV_{DD} + 0.3$ V
REFOUT to AGND	$AV_{SS}$ to $AV_{DD}$
TEMP	$AV_{SS}$ to $AV_{DD}$
VOU <sub>Tx</sub> to AGND	$AV_{SS}$ to $AV_{DD}$
AGND to DGND	-0.3 V to +0.3 V
Operating Temperature Range Industrial	-40°C to +85°C
Storage Temperature Range	-65°C to +150°C
Junction Temperature ( $T_J$ max)	150°C
Lead Temperature (Soldering)	JEDEC Industry Standard J-STD-020

Stresses above those listed under Absolute Maximum Ratings may cause permanent damage to the device. This is a stress rating only; functional operation of the device at these or any other conditions above those indicated in the operational section of this specification is not implied. Exposure to absolute maximum rating conditions for extended periods may affect device reliability.

### THERMAL RESISTANCE

$\theta_{JA}$  is specified for the worst-case conditions, that is, a device soldered in a circuit board for surface-mount packages.

**Table 5. Thermal Resistance**

Package Type	$\theta_{JA}$	$\theta_{JC}$	Unit
32-Lead TQFP	65	12	$^\circ\text{C}/\text{W}$

### ESD CAUTION



**ESD (electrostatic discharge) sensitive device.** Charged devices and circuit boards can discharge without detection. Although this product features patented or proprietary protection circuitry, damage may occur on devices subjected to high energy ESD. Therefore, proper ESD precautions should be taken to avoid performance degradation or loss of functionality.

## PIN CONFIGURATION AND FUNCTION DESCRIPTIONS

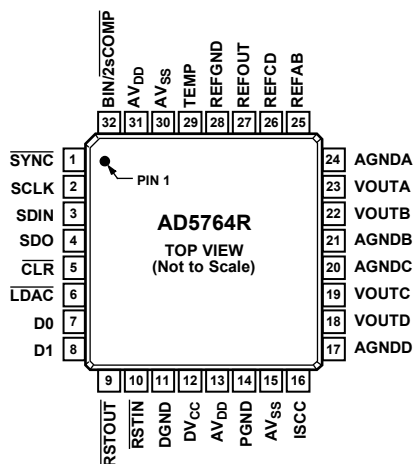

Figure 6. Pin Configuration

Table 6. Pin Function Descriptions

Pin No.	Mnemonic	Description
1	SYNC	Active Low Input. This is the frame synchronization signal for the serial interface. While SYNC is low, data is transferred in on the falling edge of SCLK.
2	SCLK	Serial Clock Input. Data is clocked into the shift register on the falling edge of SCLK. This operates at clock speeds of up to 30 MHz.
3	SDIN	Serial Data Input. Data must be valid on the falling edge of SCLK.
4	SDO	Serial Data Output. This pin is used to clock data from the serial register in daisy-chain or readback mode.
5	CLR	Negative Edge Triggered Input. <sup>1</sup> Asserting this pin sets the DAC registers to 0x0000.
6	LDAC	Load DAC. This logic input is used to update the DAC registers and, consequently, the analog outputs. When tied permanently low, the addressed DAC register is updated on the rising edge of SYNC. If LDAC is held high during the write cycle, the DAC input register is updated but the output update is held off until the falling edge of LDAC. In this mode, all analog outputs can be updated simultaneously on the falling edge of LDAC. The LDAC pin must not be left unconnected.
7, 8	D0, D1	Digital I/O Port. D0 and D1 form a digital I/O port. The user can set up these pins as inputs or outputs that are configurable and readable over the serial interface. When configured as inputs, these pins have weak internal pull-ups to DV <sub>CC</sub> . When programmed as outputs, D0 and D1 are referenced by DV <sub>CC</sub> and DGND.
9	RSTOUT	Reset Logic Output. This is the output from the on-chip voltage monitor used in the reset circuit. If desired, it can be used to control other system components.
10	RSTIN	Reset Logic Input. This input allows external access to the internal reset logic. Applying a Logic 0 to this input clamps the DAC outputs to 0 V. In normal operation, RSTIN should be tied to Logic 1. Register values remain unchanged.
11	DGND	Digital Ground Pin.
12	DV <sub>CC</sub>	Digital Supply Pin. Voltage ranges from 2.7 V to 5.25 V.
13, 31	AV <sub>DD</sub>	Positive Analog Supply Pins. Voltage ranges from 11.4 V to 16.5 V.
14	PGND	Ground Reference Point for Analog Circuitry.
15, 30	AV <sub>SS</sub>	Negative Analog Supply Pins. Voltage ranges from -11.4 V to -16.5 V.
16	ISCC	This pin is used in association with an optional external resistor to AGND to program the short-circuit current of the output amplifiers. Refer to the Design Features section for more information.
17	AGNDD	Ground Reference Pin for DAC D Output Amplifier.
18	VOUTD	Analog Output Voltage of DAC D. Buffered output with a nominal full-scale output range of ±10 V. The output amplifier is capable of directly driving a 10 kΩ, 200 pF load.
19	VOUTC	Analog Output Voltage of DAC C. Buffered output with a nominal full-scale output range of ±10 V. The output amplifier is capable of directly driving a 10 kΩ, 200 pF load.
20	AGNDC	Ground Reference Pin for DAC C Output Amplifier.
21	AGNDB	Ground Reference Pin for DAC B Output Amplifier.

# AD5764R

Pin No.	Mnemonic	Description
22	VOUTB	Analog Output Voltage of DAC B. Buffered output with a nominal full-scale output range of $\pm 10$ V. The output amplifier is capable of directly driving a 10 k $\Omega$ , 200 pF load.
23	VOUTA	Analog Output Voltage of DAC A. Buffered output with a nominal full-scale output range of $\pm 10$ V. The output amplifier is capable of directly driving a 10 k $\Omega$ , 200 pF load.
24	AGNDA	Ground Reference Pin for DAC A Output Amplifier.
25	REFAB	External Reference Voltage Input for Channel A and Channel B. The reference input range is 1 V to 7 V, and it programs the full-scale output voltage. REFIN = 5 V for specified performance.
26	REFCD	External Reference Voltage Input for Channel C and Channel D. The reference input range is 1 V to 7 V, and it programs the full-scale output voltage. REFIN = 5 V for specified performance.
27	REFOUT	Reference Output. This is the reference output from the internal voltage reference. The internal reference is 5 V $\pm$ 3 mV at 25°C, with a reference temperature coefficient of 10 ppm/°C.
28	REFGND	Reference Ground Return for the Reference Generator and Buffers.
29	TEMP	This pin provides an output voltage proportional to temperature. The output voltage is 1.47 V typical at 25°C die temperature; variation with temperature is 5 mV/°C.
32	$\overline{\text{BIN/2sCOMP}}$	This pin determines the DAC coding. This pin should be hardwired to either DV <sub>CC</sub> or DGND. When hardwired to DV <sub>CC</sub> , input coding is offset binary (see Table 7). When hardwired to DGND, input coding is twos complement (see Table 8).

<sup>1</sup> Internal pull-up device on this logic input. Therefore, it can be left floating; and it defaults to a logic high condition.

# TYPICAL PERFORMANCE CHARACTERISTICS

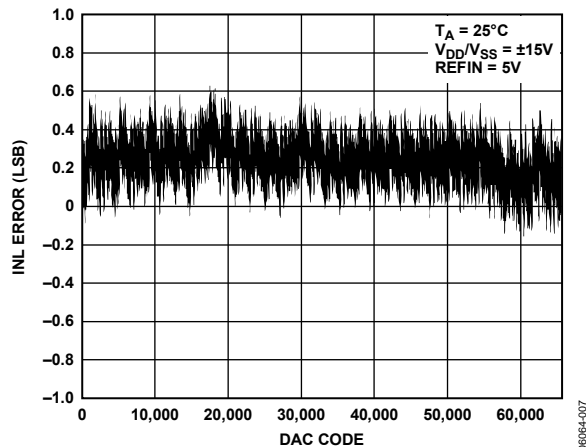

Figure 7. Integral Nonlinearity Error vs. DAC Code,  $V_{DD}/V_{SS} = \pm 15 V$

06064-007

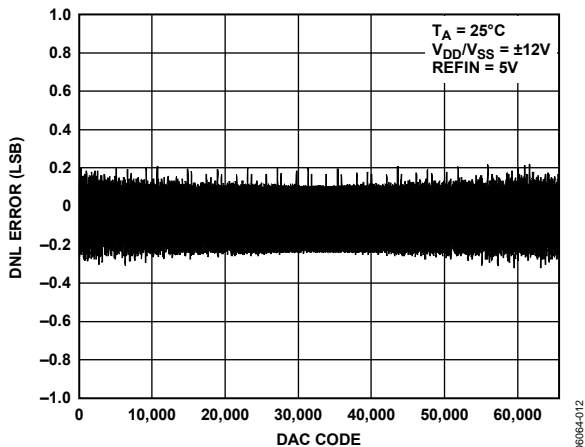

Figure 10. Differential Nonlinearity Error vs. DAC Code,  $V_{DD}/V_{SS} = \pm 12 V$

06064-012

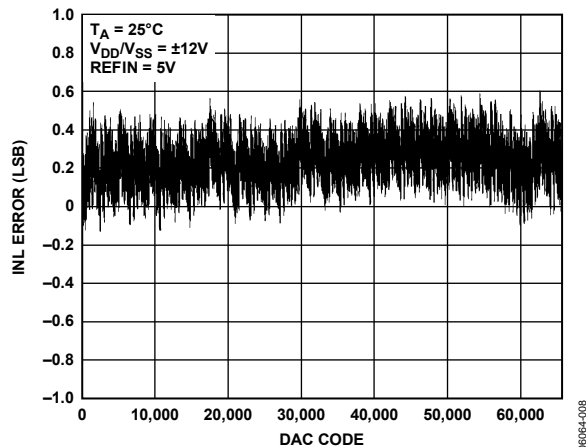

Figure 8. Integral Nonlinearity Error vs. DAC Code,  $V_{DD}/V_{SS} = \pm 12 V$

06064-008

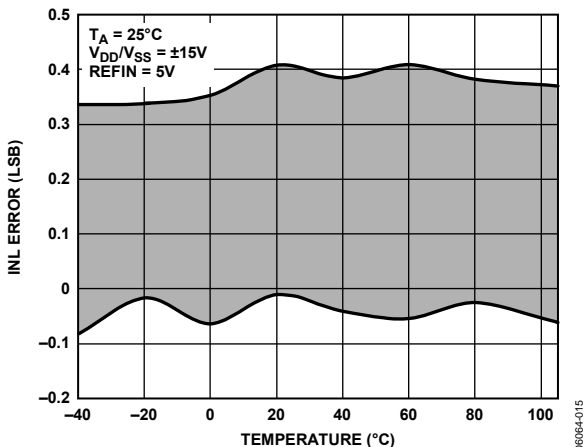

Figure 11. Integral Nonlinearity Error vs. Temperature,  $V_{DD}/V_{SS} = \pm 15 V$

06064-015

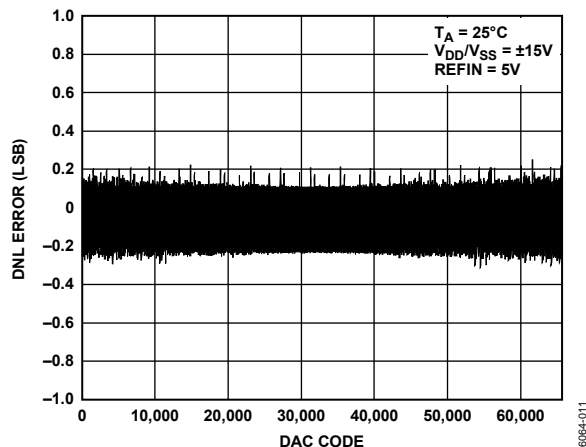

Figure 9. Differential Nonlinearity Error vs. DAC Code,  $V_{DD}/V_{SS} = \pm 15 V$

06064-011

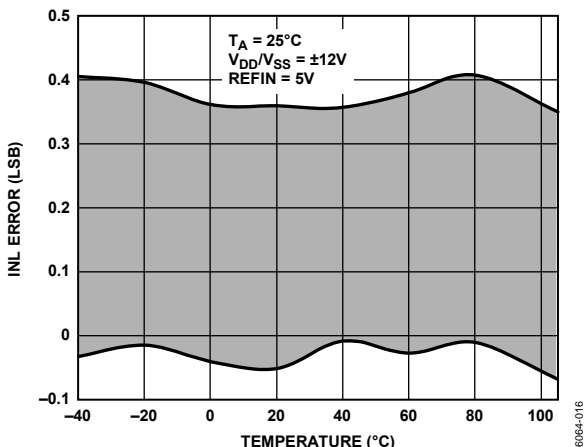

Figure 12. Integral Nonlinearity Error vs. Temperature,  $V_{DD}/V_{SS} = \pm 12 V$

06064-016

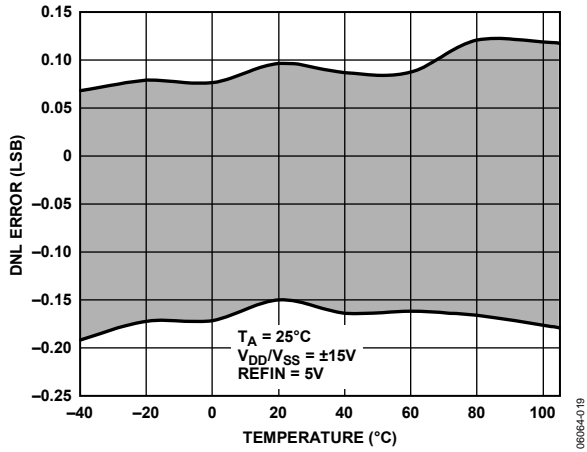

Figure 13. Differential Nonlinearity Error vs. Temperature,  $V_{DD}/V_{SS} = \pm 15\text{ V}$

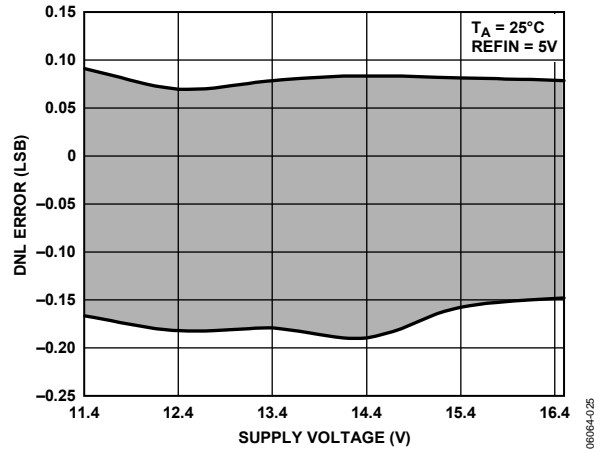

Figure 16. Differential Nonlinearity Error vs. Supply Voltage

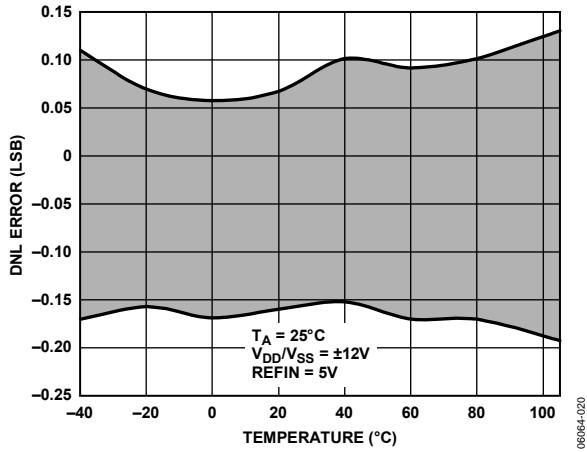

Figure 14. Differential Nonlinearity Error vs. Temperature,  $V_{DD}/V_{SS} = \pm 12\text{ V}$

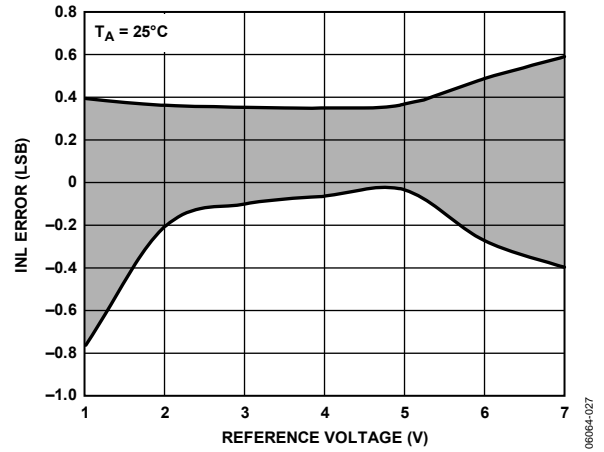

Figure 17. Integral Nonlinearity Error vs. Reference Voltage,  $V_{DD}/V_{SS} = \pm 16.5\text{ V}$

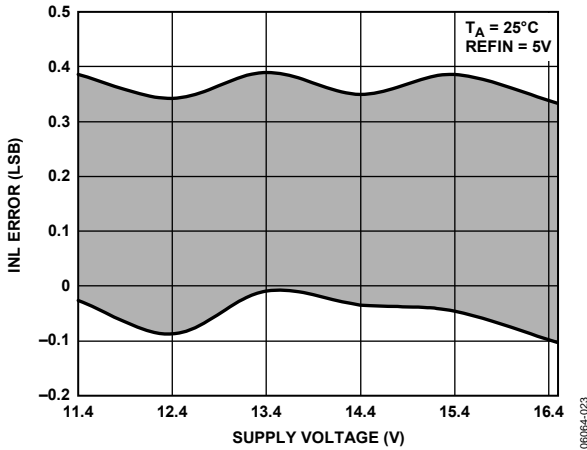

Figure 15. Integral Nonlinearity Error vs. Supply Voltage

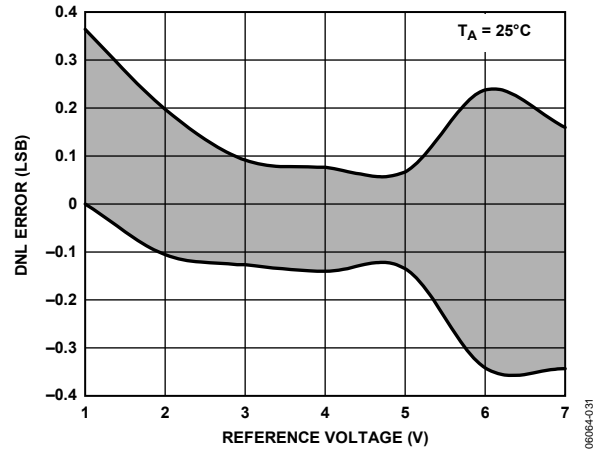

Figure 18. Differential Nonlinearity Error vs. Reference Voltage,  $V_{DD}/V_{SS} = \pm 16.5\text{ V}$

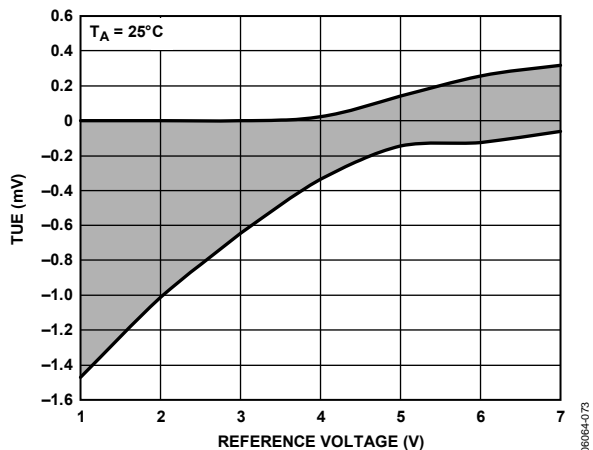

Figure 19. Total Unadjusted Error vs. Reference Voltage,  $V_{DD}/V_{SS} = \pm 16.5V$

06064-073

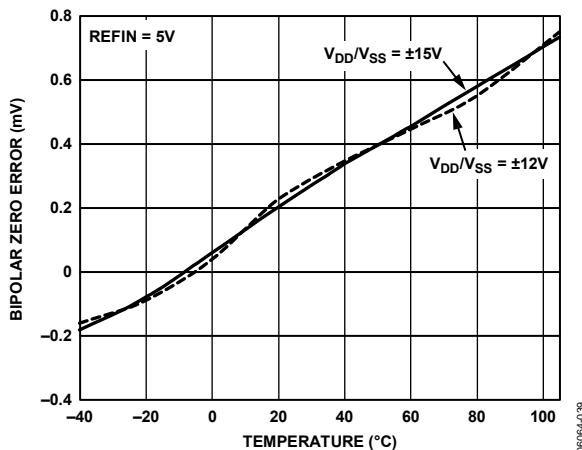

Figure 22. Bipolar Zero Error vs. Temperature

06064-038

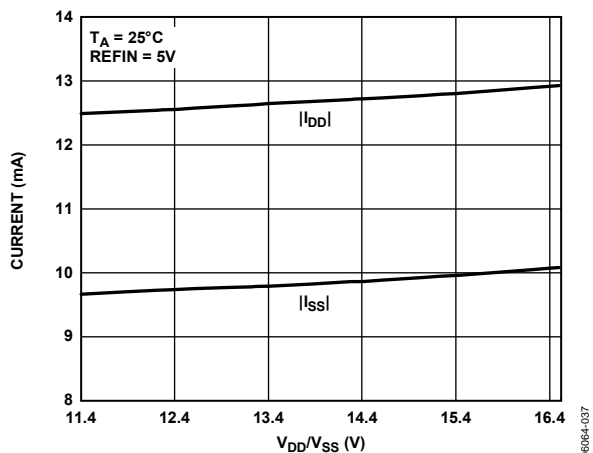

Figure 20.  $I_{DD}/I_{SS}$  vs.  $V_{DD}/V_{SS}$

06064-037

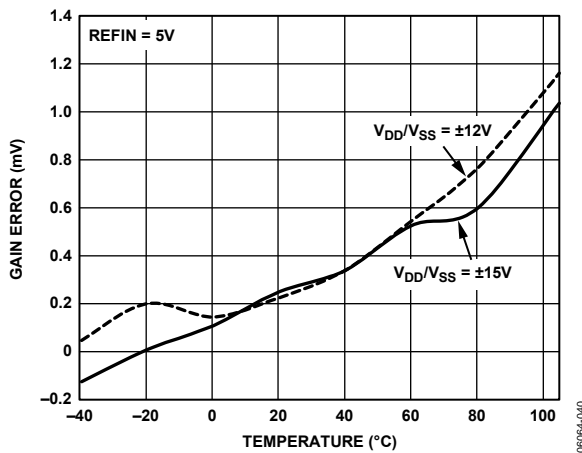

Figure 23. Gain Error vs. Temperature

06064-040

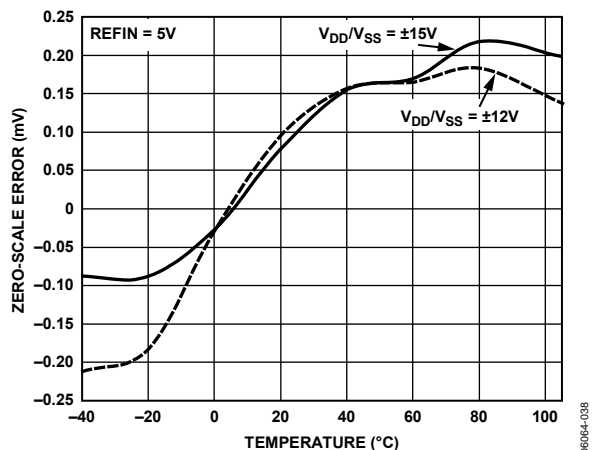

Figure 21. Zero-Scale Error vs. Temperature

06064-038

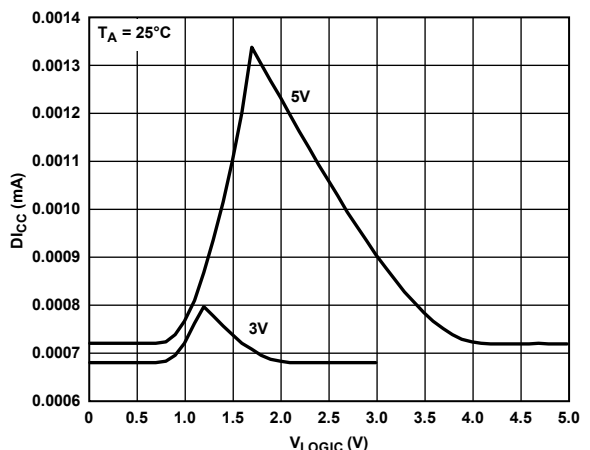

Figure 24.  $D_{ICC}$  vs. Logic Input Voltage

06064-041

# AD5764R

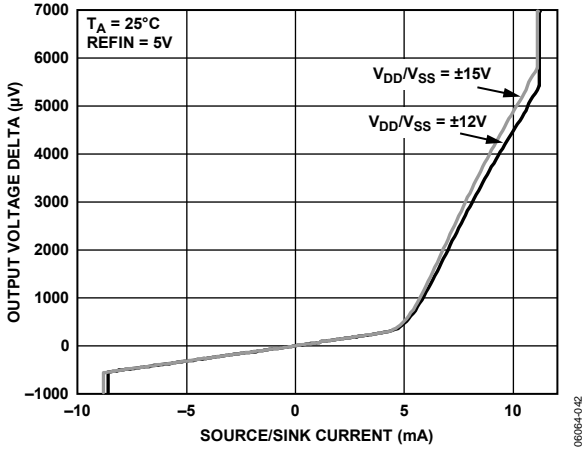

Figure 25. Source and Sink Capability of Output Amplifier with Positive Full Scale Loaded

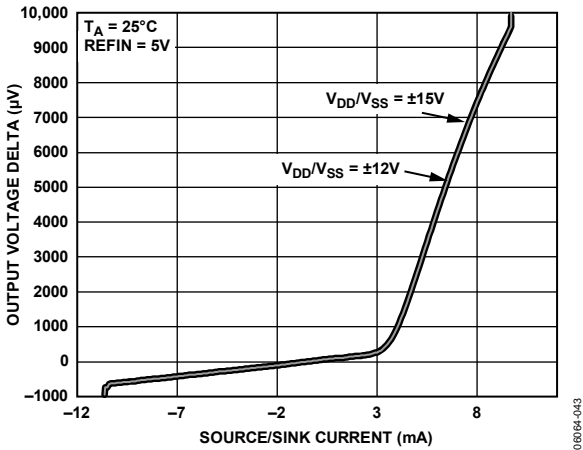

Figure 26. Source and Sink Capability of Output Amplifier with Negative Full Scale Loaded

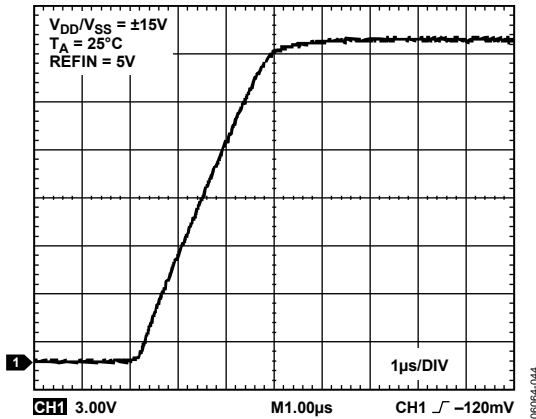

Figure 27. Full-Scale Settling Time

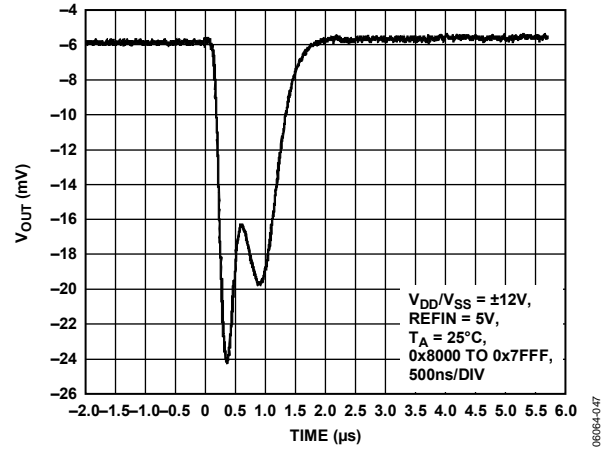

Figure 28. Major Code Transition Glitch Energy,  $V_{DD}/V_{SS} = \pm 12V$

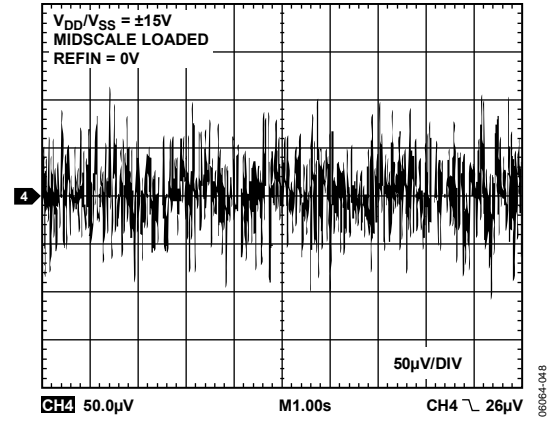

Figure 29. Peak-to-Peak Noise (100 kHz Bandwidth)

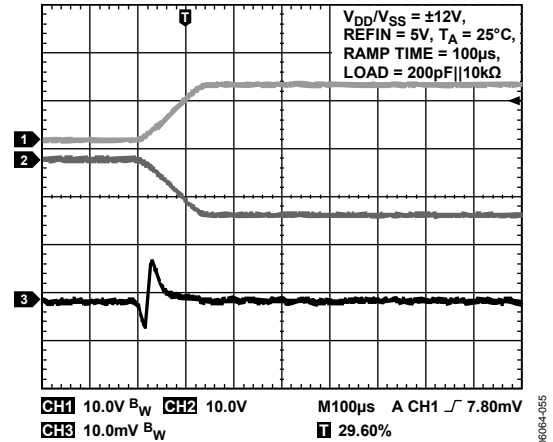

Figure 30.  $V_{OUTx}$  vs.  $V_{DD}/V_{SS}$  on Power-Up



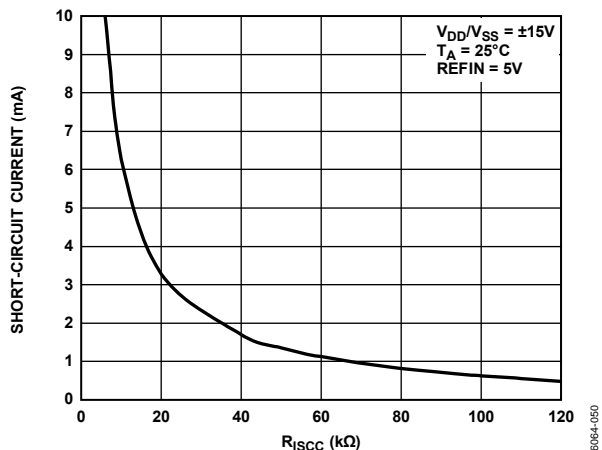

Figure 31. Short-Circuit Current vs.  $R_{isc}$

06064-050

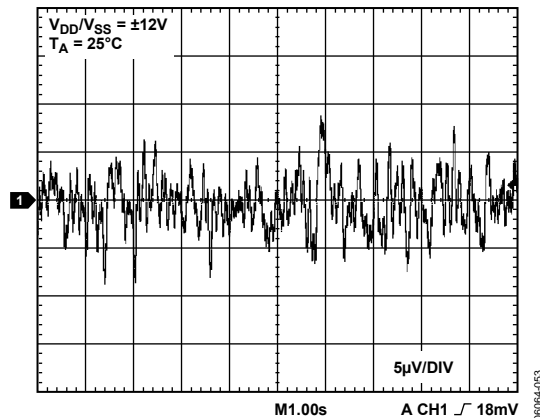

Figure 34. REFOUT Output Noise 0.1 Hz to 10 Hz

06064-053

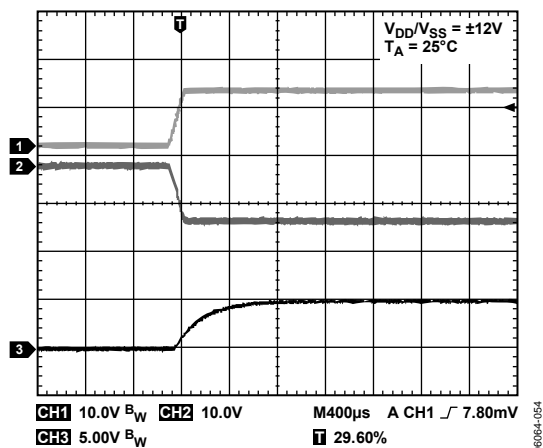

Figure 32. REFOUT Turn-On Transient

06064-054

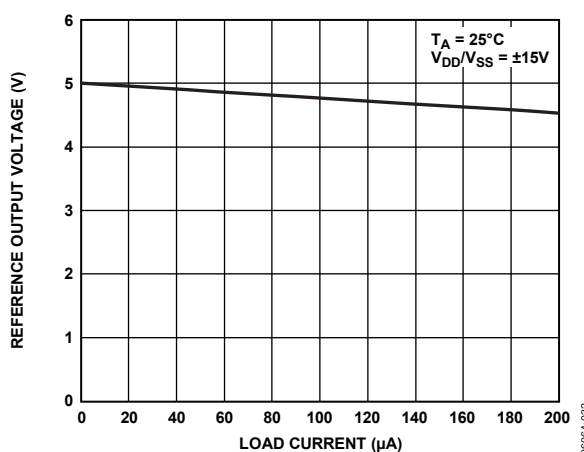

Figure 35. REFOUT Load Regulation

06064-032

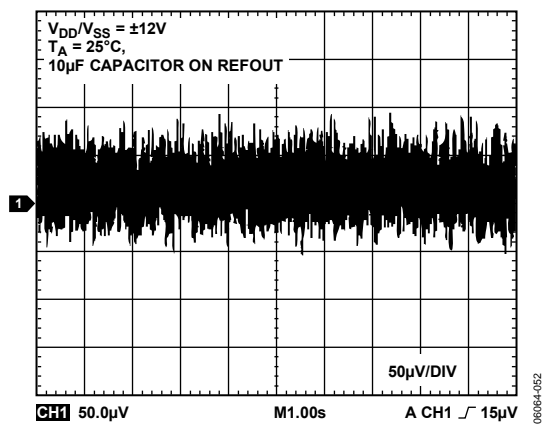

Figure 33. REFOUT Output Noise 100 kHz Bandwidth

06064-052

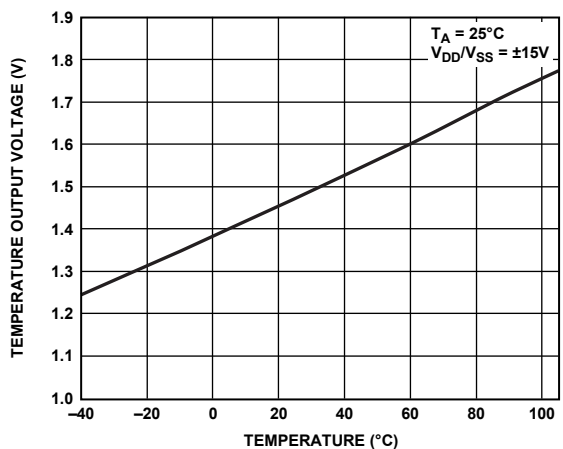

Figure 36. Temperature Output Voltage vs. Temperature

06064-033

# AD5764R

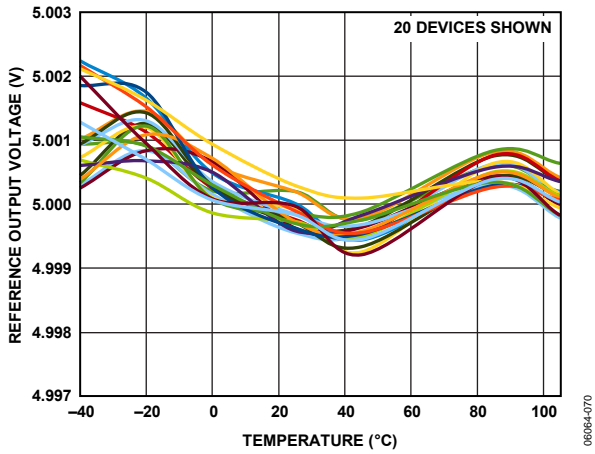

Figure 37. Reference Output Voltage vs. Temperature

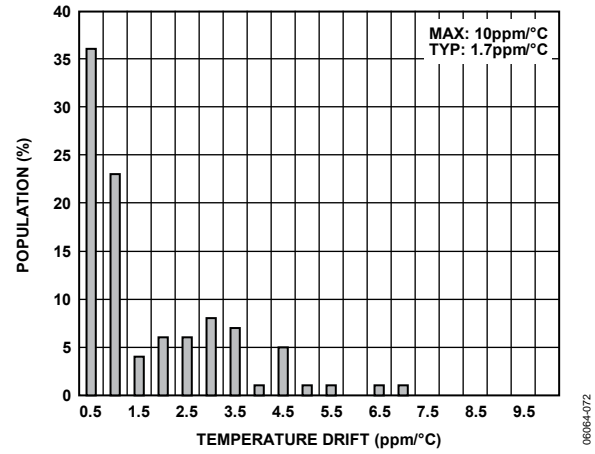

Figure 38. Reference Output Temperature Drift (-40°C to +85°C)

## TERMINOLOGY

### Relative Accuracy or Integral Nonlinearity (INL)

For the DAC, a measure of the maximum deviation, in LSBs, from a straight line passing through the endpoints of the DAC transfer function.

### Differential Nonlinearity (DNL)

The difference between the measured change and the ideal 1 LSB change between any two adjacent codes. A specified differential nonlinearity of  $\pm 1$  LSB maximum ensures monotonicity. This DAC is guaranteed monotonic.

### Monotonicity

A DAC is monotonic if the output either increases or remains constant for increasing digital input code. The AD5744R is monotonic over its full operating temperature range.

### Bipolar Zero Error

The deviation of the analog output from the ideal half-scale output of 0 V when the DAC register is loaded with 0x8000 (offset binary coding) or 0x0000 (twos complement coding). Figure 22 shows a plot of bipolar zero error vs. temperature.

### Bipolar Zero Temperature Coefficient

The measure of the change in the bipolar zero error with a change in temperature. It is expressed as parts per million of full-scale range per degree Celsius (ppm FSR/ $^{\circ}$ C).

### Full-Scale Error

The measure of the output error when full-scale code is loaded to the DAC register. Ideally, the output voltage should be  $2 \times V_{\text{REFIN}} - 1$  LSB. Full-scale error is expressed as a percentage of full-scale range (% FSR).

### Negative Full-Scale Error/Zero-Scale Error

The error in the DAC output voltage when 0x0000 (offset binary coding) or 0x8000 (twos complement coding) is loaded to the DAC register. Ideally, the output voltage should be  $-2 \times V_{\text{REFIN}}$ . Figure 21 shows a plot of zero-scale error vs. temperature.

### Output Voltage Settling Time

The amount of time it takes for the output to settle to a specified level for a full-scale input change.

### Slew Rate

A limitation in the rate of change of the output voltage. The output slewing speed of a voltage-output DAC is usually limited by the slew rate of the amplifier used at its output. Slew rate is measured from 10% to 90% of the output signal and is given in volts per microsecond (V/ $\mu$ s).

### Gain Error

A measure of the span error of the DAC. It is the deviation in slope of the DAC transfer characteristic from the ideal, expressed as a percentage of the full-scale range (% FSR). Figure 23 shows a plot of gain error vs. temperature.

### Total Unadjusted Error (TUE)

A measure of the output error, considering all the various errors. Figure 19 shows a plot of total unadjusted error vs. reference voltage.

### Zero-Scale Error Temperature Coefficient

A measure of the change in zero-scale error with a change in temperature. It is expressed as parts per million of full-scale range per degree Celsius (ppm FSR/ $^{\circ}$ C).

### Gain Error Temperature Coefficient

A measure of the change in gain error with changes in temperature. It is expressed as parts per million of full-scale range per degree Celsius (ppm FSR/ $^{\circ}$ C).

### Digital-to-Analog Glitch Energy

The impulse injected into the analog output when the input code in the DAC register changes state. It is normally specified as the area of the glitch in nanovolt-seconds (nV-sec) and is measured when the digital input code is changed by 1 LSB at the major carry transition (0x7FFF to 0x8000), as shown in Figure 28.

### Digital Feedthrough

A measure of the impulse injected into the analog output of the DAC from the digital inputs of the DAC, but measured when the DAC output is not updated. It is specified in nanovolt-seconds (nV-sec) and measured with a full-scale code change on the data bus, that is, from all 0s to all 1s, and vice versa.

### Power Supply Sensitivity

Indicates how the output of the DAC is affected by changes in the power supply voltage.

### DC Crosstalk

The dc change in the output level of one DAC in response to a change in the output of another DAC. It is measured with a full-scale output change on one DAC while monitoring another DAC, and is expressed in least significant bits (LSBs).

### DAC-to-DAC Crosstalk

The glitch impulse transferred to the output of one DAC due to a digital code change and subsequent output change of another DAC. This includes both digital and analog crosstalk. It is measured by loading one of the DACs with a full-scale code change (from all 0s to all 1s, and vice versa) with  $\overline{\text{LDAC}}$  low and monitoring the output of another DAC. The energy of the glitch is expressed in nanovolt-seconds (nV-sec).

### Channel-to-Channel Isolation

The ratio of the amplitude of the signal at the output of one DAC to a sine wave on the reference input of another DAC. It is measured in decibels (dB).

### Reference Temperature Coefficient

A measure of the change in the reference output voltage with a change in temperature. It is expressed in parts per million per degree Celsius (ppm/ $^{\circ}$ C).

# AD5764R

## **Digital Crosstalk**

A measure of the impulse injected into the analog output of one DAC from the digital inputs of another DAC but is measured when the DAC output is not updated. It is specified in nanovolt-seconds (nV-sec) and measured with a full-scale code change on the data bus; that is, from all 0s to all 1s, and vice versa.

## **Thermal Hysteresis**

The change of reference output voltage after the device is cycled through temperatures from  $-40^{\circ}\text{C}$  to  $+85^{\circ}\text{C}$  and back to  $-40^{\circ}\text{C}$ . This is a typical value from a sample of parts put through such a cycle.

## THEORY OF OPERATION

The AD5764R is a quad, 16-bit, serial input, bipolar voltage output DAC that operates from supply voltages of  $\pm 11.4\text{ V}$  to  $\pm 16.5\text{ V}$  and has a buffered output voltage of up to  $\pm 10.5263\text{ V}$ . Data is written to the AD5764R in a 24-bit word format via a 3-wire serial interface. The AD5764R also offers an SDO pin that is available for daisy chaining or readback.

The AD5764R incorporates a power-on reset circuit that ensures that the DAC registers are loaded with 0x0000 at power-up. The AD5764R features a digital I/O port that can be programmed via the serial interface, an analog die temperature sensor, on-chip 10 ppm/ $^{\circ}\text{C}$  voltage reference, on-chip reference buffers, and per channel digital gain and offset registers.

### DAC ARCHITECTURE

The DAC architecture of the AD5764R consists of a 16-bit current mode segmented R-2R DAC. The simplified circuit diagram for the DAC section is shown in Figure 39.

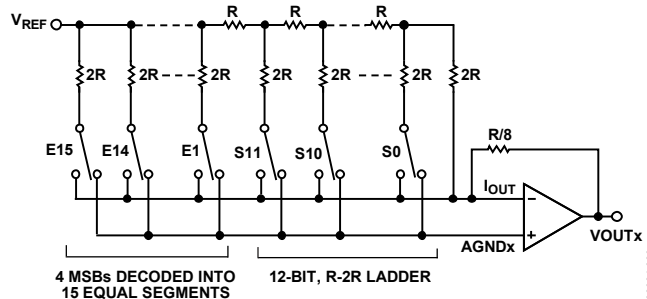

Figure 39. DAC Ladder Structure

The four MSBs of the 16-bit data-word are decoded to drive 15 switches, E1 to E15. Each of these switches connects one of the 15 matched resistors to either  $\text{AGND}_x$  or  $\text{IOUT}$ . The remaining 12 bits of the data-word drive Switch S0 to Switch S11 of the 12-bit R-2R ladder network.

### REFERENCE BUFFERS

The AD5764R can operate with either an external or an internal reference. The reference inputs (REFAB and REFC) have an input range of up to 7 V. This input voltage is then used to provide a buffered positive and negative reference for the DAC cores. The positive reference is given by

$$+V_{REF} = 2 \times V_{REFIN}$$

The negative reference to the DAC cores is given by

$$-V_{REF} = -2 \times V_{REFIN}$$

These positive and negative reference voltages (along with the gain register values) define the output ranges of the DACs.

### SERIAL INTERFACE

The AD5764R is controlled over a versatile 3-wire serial interface that operates at clock rates of up to 30 MHz and is compatible with SPI, QSPI™, MICROWIRE™, and DSP standards.

#### Input Shift Register

The input shift register is 24 bits wide. Data is loaded into the device, MSB first, as a 24-bit word under the control of a serial clock input, SCLK. The input register consists of a read/write bit, a reserved bit that must be set to 0, three register select bits, three DAC address bits, and 16 data bits, as shown in Table 9. The timing diagram for this operation is shown in Figure 2.

Upon power-up, the DAC registers are loaded with zero code (0x0000) and the outputs are clamped to 0 V via a low impedance path. The outputs can be updated with the zero code value by asserting either LDAC or CLR. The corresponding output voltage depends on the state of the BIN/2sCOMP pin. If the BIN/2sCOMP pin is tied to DGND, the data coding is twos complement and the outputs update to 0 V. If the BIN/2sCOMP pin is tied to  $\text{DV}_{CC}$ , the data coding is offset binary and the outputs update to negative full scale. To have the outputs power up with zero code loaded to the outputs, the CLR pin should be held low during power-up.

#### Standalone Operation

The serial interface works with both a continuous and noncontinuous serial clock. A continuous SCLK source can be used only if SYNC is held low for the correct number of clock cycles. In gated clock mode, a burst clock containing the exact number of clock cycles must be used, and SYNC must be taken high after the final clock to latch the data. The first falling edge of SYNC starts the write cycle. Exactly 24 falling clock edges must be applied to SCLK before SYNC is brought high again. If SYNC is brought high before the 24<sup>th</sup> falling SCLK edge, then the data written is invalid. If more than 24 falling SCLK edges are applied before SYNC is brought high, the input data is also invalid. The input register addressed is updated on the rising edge of SYNC. For another serial transfer to take place, SYNC must be brought low again. After the end of the serial data transfer, data is automatically transferred from the input shift register to the addressed register.

When the data has been transferred into the chosen register of the addressed DAC, all DAC registers and outputs can be updated by taking LDAC low.

# AD5764R

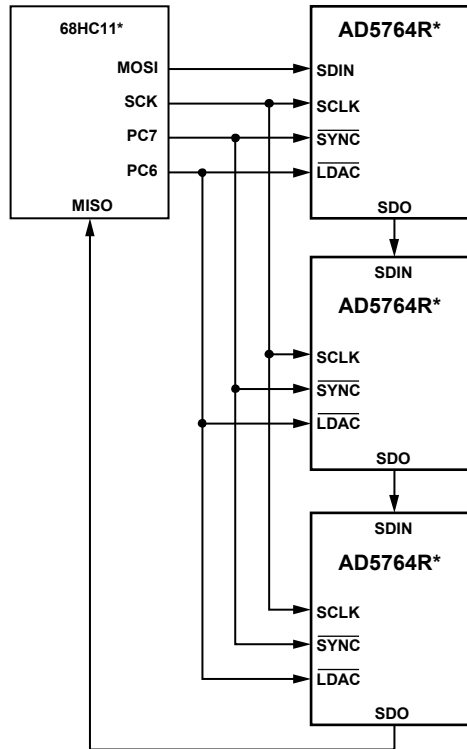

\*ADDITIONAL PINS OMITTED FOR CLARITY.

Figure 40. Daisy-Chaining the AD5764R

## Daisy-Chain Operation

For systems that contain several devices, the SDO pin can be used to daisy-chain several devices together. This daisy-chain mode can be useful in system diagnostics and in reducing the number of serial interface lines. The first falling edge of  $\overline{\text{SYNC}}$  starts the write cycle. The SCLK is continuously applied to the input shift register when  $\overline{\text{SYNC}}$  is low. If more than 24 clock pulses are applied, the data ripples out of the shift register and appears on the SDO line. This data is clocked out on the rising edge of SCLK and is valid on the falling edge. By connecting the SDO of the first device to the SDIN input of the next device in the chain, a multidevice interface is constructed. Each device in the system requires 24 clock pulses. Therefore, the total number of clock cycles must equal  $24n$ , where  $n$  is the total number of AD5764R devices in the chain. When the serial transfer to all devices is complete,  $\overline{\text{SYNC}}$  is taken high. This latches the input data in each device in the daisy chain and prevents any further data from being clocked into the input shift register. The serial clock can be a continuous or a gated clock.

A continuous SCLK source can be used only if  $\overline{\text{SYNC}}$  is held low for the correct number of clock cycles. In gated clock mode, a burst clock containing the exact number of clock cycles must be used, and  $\overline{\text{SYNC}}$  must be taken high after the final clock to latch the data.

## Readback Operation

Before a readback operation is initiated, the SDO pin must be enabled by writing to the function register and clearing the SDO disable bit; this bit is cleared by default. Readback mode is invoked by setting the R/W bit to 1 in the serial input register write. With R/W set to 1, Bit A2 to Bit A0, in association with Bit REG2 to Bit REG0, select the register to be read. The remaining data bits in the write sequence are don't care. During the next SPI write, the data appearing on the SDO output contains the data from the previously addressed register. For a read of a single register, the NOP command can be used in clocking out the data from the selected register on SDO. The readback diagram in Figure 4 shows the readback sequence. For example, to read back the fine gain register of Channel A, implement the following sequence:

1. Write 0xA0XXXX to the input register. This write configures the AD5764R for read mode with the fine gain register of Channel A selected. Note that all the data bits, DB15 to DB0, are don't care.
2. Follow with a second write: an NOP condition, 0x00XXXX. During this write, the data from the fine gain register is clocked out on the SDO line; that is, data clocked out contains the data from the fine gain register in Bit DB5 to Bit DB0.

## SIMULTANEOUS UPDATING VIA $\overline{\text{LDAC}}$

Depending on the status of both  $\overline{\text{SYNC}}$  and  $\overline{\text{LDAC}}$ , and after data has been transferred into the input register of the DACs, there are two ways to update the DAC registers and DAC outputs.

### Individual DAC Updating

In individual DAC updating mode,  $\overline{\text{LDAC}}$  is held low while data is being clocked into the input shift register. The addressed DAC output is updated on the rising edge of  $\overline{\text{SYNC}}$ .

### Simultaneous Updating of All DACs

In simultaneous updating of all DACs mode,  $\overline{\text{LDAC}}$  is held high while data is being clocked into the input shift register. All DAC outputs are updated by taking  $\overline{\text{LDAC}}$  low any time after  $\overline{\text{SYNC}}$  has been taken high. The update then occurs on the falling edge of  $\overline{\text{LDAC}}$ .

See Figure 41 for a simplified block diagram of the DAC load circuitry.

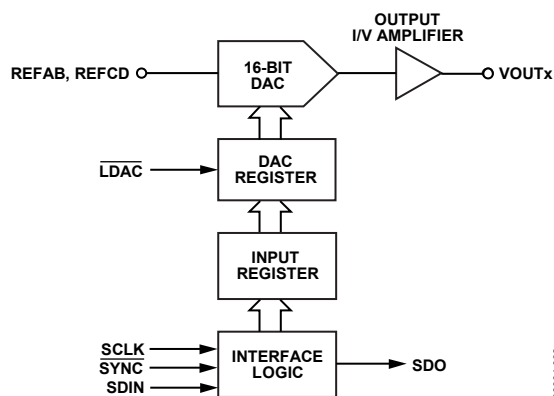

Figure 41. Simplified Serial Interface of Input Loading Circuitry for One DAC Channel

## TRANSFER FUNCTION

Table 7 and Table 8 show the ideal input code to output voltage relationship for offset binary data coding and twos complement data coding, respectively.

Table 7. Ideal Output Voltage to Input Code Relationship—Offset Binary Data Coding

Digital Input				Analog Output
MSB			LSB	V <sub>OUT</sub>
1111	1111	1111	1111	+2 V <sub>REFIN</sub> × (32,767/32,768)
1000	0000	0000	0001	+2 V <sub>REFIN</sub> × (1/32,768)
1000	0000	0000	0000	0 V
0111	1111	1111	1111	-2 V <sub>REFIN</sub> × (1/32,768)
0000	0000	0000	0000	-2 V <sub>REFIN</sub> × (32,767/32,768)

Table 8. Ideal Output Voltage to Input Code Relationship—Twos Complement Data Coding

Digital Input				Analog Output
MSB			LSB	V <sub>OUT</sub>
0111	1111	1111	1111	+2 V <sub>REFIN</sub> × (32,767/32,768)
0000	0000	0000	0001	+2 V <sub>REFIN</sub> × (1/32,768)
0000	0000	0000	0000	0 V
1111	1111	1111	1111	-2 V <sub>REFIN</sub> × (1/32,768)
1000	0000	0000	0000	-2 V <sub>REFIN</sub> × (32,767/32,768)

The output voltage expression for the AD5764R is given by

$$V_{OUT} = -2 \times V_{REFIN} + 4 \times V_{REFIN} \left[ \frac{D}{65,536} \right]$$

where:

$D$  is the decimal equivalent of the code loaded to the DAC.

$V_{REFIN}$  is the reference voltage applied at the REFAB and REFCD pins.

## ASYNCHRONOUS CLEAR ( $\overline{CLR}$ )

$\overline{CLR}$  is a negative edge triggered clear that allows the outputs to be cleared to either 0 V (twos complement coding) or negative full scale (offset binary coding). It is necessary to maintain  $\overline{CLR}$  low for a minimum amount of time for the operation to complete (see Figure 2). When the  $\overline{CLR}$  signal is returned high, the output remains at the cleared value until a new value is programmed.

If  $\overline{CLR}$  is at 0 V at power-on, all DAC outputs are updated with the clear value. A clear can also be initiated through software by writing the command of 0x04XXXX.

# AD5764R

## REGISTERS

Table 9. Input Shift Register Format

MSB									LSB
DB23	DB22	DB21	DB20	DB19	DB18	DB17	DB16	DB15 to DB1	DB0
R/W	0	REG2	REG1	REG0	A2	A1	A0	Data	

Table 10. Input Shift Register Bit Function Descriptions

Register Bit	Description			
R/W	Indicates a read from or a write to the addressed register			
REG2, REG1, REG0	Used in association with the address bits, determines if a read or write operation is to the data register, offset register, gain register, or function register			
	REG2	REG1	REG0	Function
	0	0	0	Function register
	0	1	0	Data register
	0	1	1	Coarse gain register
	1	0	0	Fine gain register
	1	0	1	Offset register
A2, A1, A0	Decodes the DAC channels			
	A2	A1	A0	Channel Address
	0	0	0	DAC A
	0	0	1	DAC B
	0	1	0	DAC C
	0	1	1	DAC D
	1	0	0	All DACs
Data	Data bits			

## FUNCTION REGISTER

The function register is addressed by setting the three REG bits to 000. The values written to the address bits and the data bits determine the function addressed. The functions available via the function register are outlined in Table 11 and Table 12.

Table 11. Function Register Options

REG2	REG1	REG0	A2	A1	A0	DB15 to DB6	DB5	DB4	DB3	DB2	DB1	DB0
0	0	0	0	0	0	NOP, data = don't care						
0	0	0	0	0	1	Don't care	Local ground offset adjust	D1 direction	D1 value	D0 direction	D0 value	SDO disable
0	0	0	1	0	0	Clear, data = don't care						
0	0	0	1	0	1	Load, data = don't care						

Table 12. Explanation of Function Register Options

Option	Description
NOP	No operation instruction used in readback operations.
Local Ground Offset Adjust	Set by the user to enable the local ground offset adjust function. Cleared by the user to disable the local ground offset adjust function (default). See the Design Features section for more information.
D0, D1 Direction	Set by the user to enable the D0 and D1 pins as outputs. Cleared by the user to enable the D0 and D1 pins as inputs (default). See the Design Features section for more information.
D0, D1 Value	I/O port status bits. Logic values written to these locations determine the logic outputs on the D0 and D1 pins when configured as outputs. These bits indicate the status of the D0 and D1 pins when the I/O port is active as an input. When enabled as inputs, these bits are don't cares during a write operation.
SDO Disable	Set by the user to disable the SDO output. Cleared by the user to enable the SDO output (default).
Clear	Addressing this function resets the DAC outputs to 0 V in twos complement mode and negative full scale in binary mode.
Load	Addressing this function updates the DAC registers and consequently the analog outputs.



## DATA REGISTER

The data register is addressed by setting the three REG bits to 010. The DAC address bits select the DAC channel with which the data transfer takes place (see Table 10). The data bits are positioned in DB15 to DB0, as shown in Table 13.

**Table 13. Programming the Data Register**

REG2	REG1	REG0	A2	A1	A0	DB15 to DB0
0	1	0	DAC address			16-bit DAC data

## COARSE GAIN REGISTER

The coarse gain register is addressed by setting the three REG bits to 011. The DAC address bits select the DAC channel with which the data transfer takes place (see Table 10). The coarse gain register is a 2-bit register that allows the user to select the output range of each DAC, as shown in Table 15.

**Table 14. Programming the Coarse Gain Register**

REG2	REG1	REG0	A2	A1	A0	DB15 to DB2	DB1	DB0
0	1	1	DAC address			Don't care	CG1	CG0

**Table 15. Output Range Selection**

Output Range	CG1	CG0
±10 V (Default)	0	0
±10.2564 V	0	1
±10.5263 V	1	0

## FINE GAIN REGISTER

The fine gain register is addressed by setting the three REG bits to 100. The DAC address bits select the DAC channel with which the data transfer takes place (see Table 10). The AD5764R fine gain register is a 6-bit register that allows the user to adjust the gain of each DAC channel by –32 LSBs to +31 LSBs in 1 LSB steps, as shown in Table 16 and Table 17. The adjustment is made to both the positive full-scale points and the negative full-scale points simultaneously, with each point adjusted by one-half of one step. The fine gain register coding is two's complement.

**Table 16. Programming the Fine Gain Register**

REG2	REG1	REG0	A2	A1	A0	DB15 to DB6	DB5	DB4	DB3	DB2	DB1	DB0
1	0	0	DAC address			Don't care	FG5	FG4	FG3	FG2	FG1	FG0

**Table 17. Fine Gain Register Options**

Gain Adjustment	FG5	FG4	FG3	FG2	FG1	FG0
+31 LSBs	0	1	1	1	1	1
+30 LSBs	0	1	1	1	1	0
No Adjustment (Default)	0	0	0	0	0	0
–31 LSBs	1	0	0	0	0	1
–32 LSBs	1	0	0	0	0	0

# AD5764R

## OFFSET REGISTER

The offset register is addressed by setting the three REG bits to 101. The DAC address bits select the DAC channel with which the data transfer takes place (see Table 10). The AD5764R offset register is an 8-bit register that allows the user to adjust the offset of each channel by –16 LSBs to +15.875 LSBs in steps of one-eighth LSB, as shown in Table 18 and Table 19. The offset register coding is twos complement.

**Table 18. Programming the Offset Register**

REG2	REG1	REG0	A2	A1	A0	DB15 to DB8	DB7	DB6	DB5	DB4	DB3	DB2	DB1	DB0
1	0	1	DAC address			Don't care	OF7	OF6	OF5	OF4	OF3	OF2	OF1	OF0

**Table 19. Offset Register Options**

Offset Adjustment	OF7	OF6	OF5	OF4	OF3	OF2	OF1	OF0
+15.875 LSBs	0	1	1	1	1	1	1	1
+15.75 LSBs	0	1	1	1	1	1	1	0
No Adjustment (Default)	0	0	0	0	0	0	0	0
–15.875 LSBs	1	0	0	0	0	0	0	1
–16 LSBs	1	0	0	0	0	0	0	0

## OFFSET AND GAIN ADJUSTMENT WORKED EXAMPLE

Using the information provided in the Offset Register section, the following worked examples demonstrate how the AD5764R functions can be used to eliminate both offset and gain errors. Because the AD5764R is factory calibrated, offset and gain errors should be negligible. However, errors can be introduced by the system within which the AD5764R is operating. For example, a voltage reference value that is not equal to 5 V introduces a gain error. An output range of ±10 V and twos complement data coding are assumed.

### Removing Offset Error

The AD5764R can eliminate an offset error in the range of –4.88 mV to +4.84 mV with a step size of one-eighth of a 16-bit LSB.

1. Calculate the step size of the offset adjustment, using the following equation:

$$\text{Offset Adjust Step Size} = \frac{20}{2^{16} \times 8} = 38.14 \mu\text{V}$$

2. Measure the offset error by programming 0x0000 to the data register and measuring the resulting output voltage. For this example, the measured value is 614 μV.
3. Determine how many offset adjustment steps this value represents, using the following equation:

$$\text{Number of Steps} = \frac{\text{Measured Offset Value}}{\text{Offset Step Size}} = \frac{614 \mu\text{V}}{38.14 \mu\text{V}} = 16 \text{ Steps}$$

The offset error measured is positive; therefore, a negative adjustment of 16 steps is required. The offset register is eight bits wide, and the coding is twos complement.

The required offset register value can be calculated as follows:

1. Convert the adjustment value to binary: 00010000.
2. Convert this binary value to a negative twos complement number by inverting all bits and adding 1: 11110000.
3. Program this value, 11110000, to the offset register.

Note that this twos complement conversion is not necessary in the case of a positive offset adjustment. The value to be programmed to the offset register is simply the binary representation of the adjustment value.

### Removing Gain Error

The AD5764R can eliminate a gain error at negative full-scale output in the range of –9.77 mV to +9.46 mV with a step size of one-half of a 16-bit LSB.

1. Calculate the step size of the gain adjustment, using the following equation:

$$\text{Gain Adjust Step Size} = \frac{20}{2^{16} \times 2} = 152.59 \mu\text{V}$$

2. Measure the gain error by programming 0x8000 to the data register and measuring the resulting output voltage. The gain error is the difference between this value and –10 V. For this example, the gain error is –1.2 mV.
3. Determine how many gain adjustment steps this value represents, using the following equation:

$$\text{Number of Steps} = \frac{\text{Measured Gain Value}}{\text{Gain Step Size}} = \frac{1.2 \text{ mV}}{152.59 \mu\text{V}} = 8 \text{ Steps}$$

The gain error measured is negative (in terms of magnitude). Therefore, a positive adjustment of eight steps is required. The gain register is six bits wide, and the coding is twos complement. The required gain register value can be determined as follows:

1. Convert the adjustment value to binary: 001000.
2. Program this binary number to the gain register.

## DESIGN FEATURES

### ANALOG OUTPUT CONTROL

In many industrial process control applications, it is vital that the output voltage be controlled during power-up and during brownout conditions. When the supply voltages are changing, the VOUTx pins are clamped to 0 V via a low impedance path. To prevent the output amp from being shorted to 0 V during this time, Transmission Gate G1 is also opened (see Figure 42).

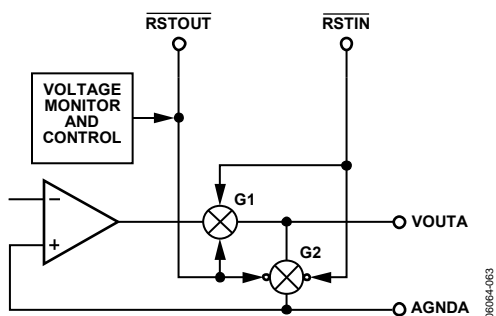

Figure 42. Analog Output Control Circuitry

These conditions are maintained until the power supplies stabilize and a valid word is written to the DAC register. G2 then opens, and G1 closes. Both transmission gates are also externally controllable by using the reset in (RSTIN) control input. For example, if RSTIN is driven from a battery supervisor chip, the RSTIN input is driven low to open G1 and close G2 on power-off or during a brownout. Conversely, the on-chip voltage detector output (RSTOUT) is also available to the user to control other parts of the system. The basic transmission gate functionality is shown in Figure 42.

### DIGITAL OFFSET AND GAIN CONTROL

The AD5764R incorporates a digital offset adjust function with a  $\pm 16$  LSB adjust range and 0.125 LSB resolution. The gain register allows the user to adjust the AD5764R full-scale output range. The full-scale output can be programmed to achieve full-scale ranges of  $\pm 10$  V,  $\pm 10.25$  V, and  $\pm 10.5$  V. A fine gain trim is also available.

### PROGRAMMABLE SHORT-CIRCUIT PROTECTION

The short-circuit current ( $I_{SC}$ ) of the output amplifiers can be programmed by inserting an external resistor between the ISCC pin and the PGND pin. The programmable range for the current is 500  $\mu$ A to 10 mA, corresponding to a resistor range of 120 k $\Omega$  to 6 k $\Omega$ . The resistor value is calculated as follows:

$$R \approx \frac{60}{I_{SC}}$$

If the ISCC pin is left unconnected, the short circuit current limit defaults to 5 mA. It should be noted that limiting the short circuit current to a small value can affect the slew rate of the output when driving into a capacitive load. Therefore, the value of the short-circuit current that is programmed should take into account the size of the capacitive load being driven.

### DIGITAL I/O PORT

The AD5764R contains a 2-bit digital I/O port (D1 and D0). These bits can be configured independently as inputs or outputs and can be driven or have their values read back via the serial interface. The I/O port signals are referenced to DV<sub>CC</sub> and DGND. When configured as outputs, they can be used as control signals to multiplexers or can be used to control calibration circuitry elsewhere in the system. When configured as inputs, the logic signals from limit switches, for example, can be applied to D0 and D1 and can be read back using the digital interface.

### DIE TEMPERATURE SENSOR

The on-chip die temperature sensor provides a voltage output that is linearly proportional to the Celsius temperature scale. Its nominal output voltage is 1.47 V at +25°C die temperature, varying at 5 mV/°C, giving a typical output range of 1.175 V to 1.9 V over the full temperature range. Its low output impedance, and linear output simplify interfacing to temperature control circuitry and analog-to-digital converters (ADCs). The temperature sensor is provided as more of a convenience than as a precise feature; it is intended for indicating a die temperature change for recalibration purposes.

### LOCAL GROUND OFFSET ADJUST

The AD5764R incorporates a local ground offset adjust feature that, when enabled in the function register, adjusts the DAC outputs for voltage differences between the individual DAC ground pins and the REFGND pin, ensuring that the DAC output voltages are always referenced to the local DAC ground pin. For example, if the AGNDA pin is at +5 mV with respect to the REFGND pin, and VOUTA is measured with respect to AGNDA, a -5 mV error results, enabling the local ground offset adjust feature to adjust VOUTA by +5 mV, thereby eliminating the error.

## APPLICATIONS INFORMATION

### TYPICAL OPERATING CIRCUIT

Figure 43 shows the typical operating circuit for the AD5764R. The only external components needed for this precision 16-bit DAC are decoupling capacitors on the supply pins and reference inputs, and an optional short-circuit current setting resistor. Because the AD5764R incorporates a voltage reference and reference buffers, it eliminates the need for an external bipolar reference and associated buffers, resulting in an overall savings in both cost and board space.

In Figure 43, AVDD is connected to +15 V, and AVSS is connected to -15 V, but AV<sub>DD</sub> and AV<sub>SS</sub> can operate with supplies from ±11.4 V to ±16.5 V. In Figure 43, AGND<sub>x</sub> is connected to REFGND.

#### Precision Voltage Reference Selection

To achieve the optimum performance from the AD5764R over its full operating temperature range, an external voltage reference must be used. Care must be taken in the selection of a precision voltage reference. The AD5764R has two reference inputs, REFAB and REFCD. The voltages applied to the reference inputs are used to provide a buffered positive and negative reference for the DAC cores. Therefore, any error in the voltage reference is reflected in the outputs of the device.

There are four possible sources of error to consider when choosing a voltage reference for high accuracy applications: initial accuracy, temperature coefficient of the output voltage, long term drift, and output voltage noise.

Initial accuracy error on the output voltage of an external reference could lead to a full-scale error in the DAC. Therefore, to minimize these errors, a reference with low initial accuracy error specification is preferred. Choosing a reference with an output trim adjustment, such as the [ADR425](#), allows a system designer to trim system errors out by setting the reference voltage to a voltage other than the nominal. The trim adjustment can also be used at temperature to trim out any error.

Long-term drift is a measure of how much the reference output voltage drifts over time. A reference with a tight long-term drift specification ensures that the overall solution remains relatively stable over its entire lifetime.

The temperature coefficient of a reference output voltage affects INL, DNL, and TUE. A reference with a tight temperature coefficient specification should be chosen to reduce the dependence of the DAC output voltage on ambient conditions.

In high accuracy applications, which have a relatively low noise budget, reference output voltage noise must be considered. It is important to choose a reference with as low an output noise voltage as practical for the system resolution that is required. Precision voltage references, such as the [ADR435](#) (XFET® design), produce low output noise in the 0.1 Hz to 10 Hz region. However, as the circuit bandwidth increases, filtering the output of the reference may be required to minimize the output noise.

**Table 20. Some Precision References Recommended for Use with the AD5764R**

Part No.	Initial Accuracy (mV Maximum)	Long-Term Drift (ppm Typical)	Temperature Drift (ppm/°C Maximum)	0.1 Hz to 10 Hz Noise (μV p-p Typical)
<a href="#">ADR435</a>	±6	30	3	3.5
<a href="#">ADR425</a>	±6	50	3	3.4
<a href="#">ADR02</a>	±5	50	3	10
<a href="#">ADR395</a>	±6	50	25	5
<a href="#">AD586</a>	±2.5	15	10	4

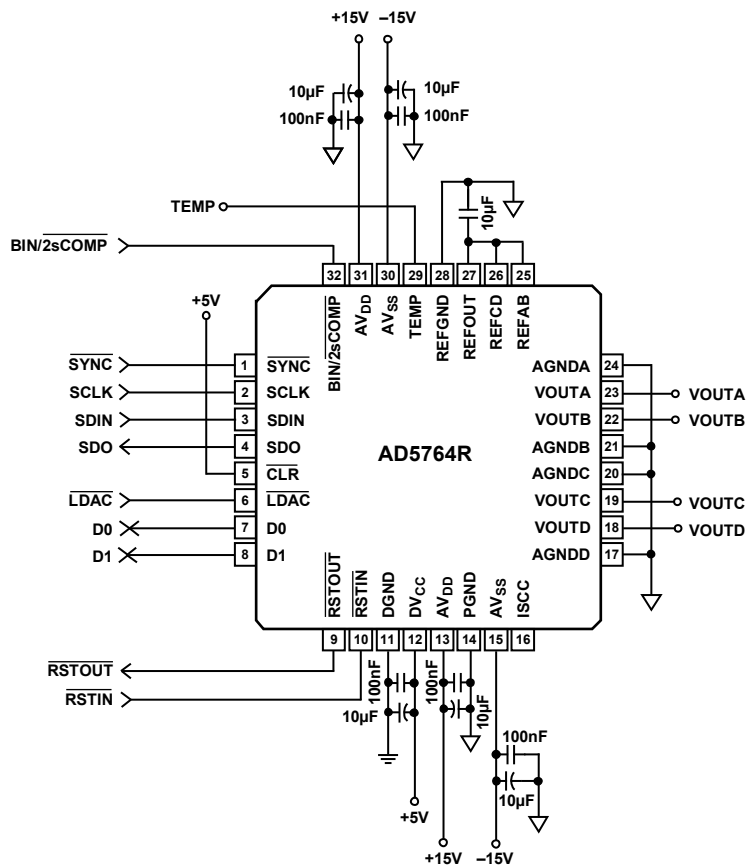

Figure 43. Typical Operating Circuit

060844-084

## LAYOUT GUIDELINES

In any circuit where accuracy is important, careful consideration of the power supply and ground return layout helps to ensure the rated performance. Design the PCB on which the AD5764R is mounted such that the analog and digital sections are separated and confined to certain areas of the board. If the AD5764R is in a system where multiple devices require an AGNDx-to-DGND connection, establish the connection at one point only. Establish the star ground point as close as possible to the device. The AD5764R should have ample supply bypassing of 10  $\mu\text{F}$  in parallel with 0.1  $\mu\text{F}$  on each supply located as close to the package as possible, ideally right up against the device. The 10  $\mu\text{F}$  capacitors are of the tantalum bead type. The 0.1  $\mu\text{F}$  capacitor should have low effective series resistance (ESR) and low effective series inductance (ESI), such as the common ceramic types that provide a low impedance path to ground at high frequencies to handle transient currents due to internal logic switching.

The power supply lines of the AD5764R should use as large a trace as possible to provide low impedance paths and reduce the effects of glitches on the power supply line. Shield fast-switching signals, such as clocks, with digital ground to avoid radiating noise to other parts of the board; they should never be run near the reference inputs. A ground line routed between the SDIN and SCLK lines helps reduce cross talk between them. (A ground line is not required on a multilayer board because it has a separate ground plane; however, it is helpful to separate the lines.) It is essential to minimize noise on the reference inputs because it couples through to the DAC output. Avoid crossover of digital and analog signals. Run traces on opposite sides of the board at right

angles to each other to reduce the effects of feedthrough on the board. A microstrip technique is recommended but not always possible with a double-sided board. In this technique, the component side of the board is dedicated to the ground plane, and the signal traces are placed on the solder side.

## GALVANICALLY ISOLATED INTERFACE

In many process control applications, it is necessary to provide an isolation barrier between the controller and the unit being controlled to protect and isolate the controlling circuitry from any hazardous common-mode voltages that may occur. Iso-couplers provide voltage isolation in excess of 2.5 kV. The serial loading structure of the AD5764R makes it ideal for isolated interfaces because the number of interface lines is kept to a minimum. Figure 44 shows a 4-channel isolated interface to the AD5764R using an ADuM1400 iCoupler<sup>®</sup> product. For more information on iCoupler products, refer to [www.analog.com](http://www.analog.com).

## MICROPROCESSOR INTERFACING

Microprocessor interfacing to the AD5764R is accomplished via a serial bus that uses standard protocol that is compatible with microcontrollers and DSP processors. The communication channel is a 3-wire (minimum) interface consisting of a clock signal, a data signal, and a synchronization signal. The AD5764R requires a 24-bit data-word with data valid on the falling edge of SCLK.

For all the interfaces, a DAC output update can be performed automatically when all the data is clocked in, or it can be done under the control of LDAC. The contents of the DAC register can be read using the readback function.

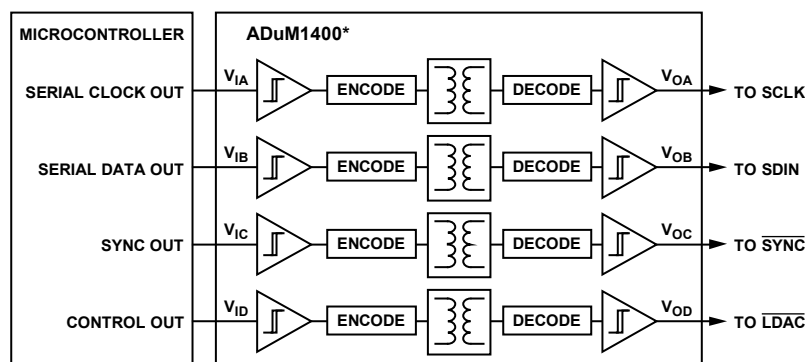

\*ADDITIONAL PINS OMITTED FOR CLARITY.

Figure 44. Isolated Interface

06064-085

**EVALUATION BOARD**

The AD5764R comes with a full evaluation board to help designers evaluate the high performance of the part with a minimum of effort. All that is required to run the evaluation board is a power supply and a PC. The AD5764R evaluation kit includes a populated, tested AD5764R PCB. The evaluation board interfaces to the

USB interface of the PC. Software that allows easy programming of the AD5764R is available with the evaluation board. The software runs on any PC that has Microsoft® Windows® 2000/XP installed.

## OUTLINE DIMENSIONS

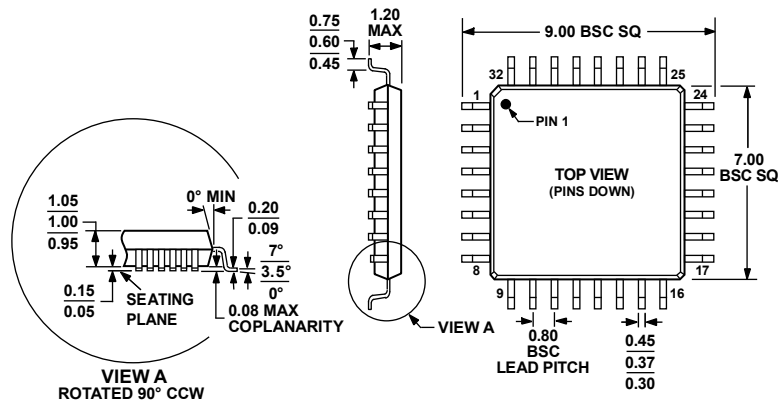

COMPLIANT TO JEDEC STANDARDS MS-026-ABA

Figure 45. 32-Lead Thin Plastic Quad Flat Package [TQFP] (SU-32-2)

Dimensions shown in millimeters

020607-A

## ORDERING GUIDE

Model	Function	INL	Temperature Range	Internal Reference	Package Description	Package Option
AD5764RBSUZ <sup>1</sup>	Quad 16-Bit DAC	±2 LSB Max	-40°C to +85°C	+5 V	32-Lead TQFP	SU-32-2
AD5764RBSUZ-REEL7 <sup>1</sup>	Quad 16-Bit DAC	±2 LSB Max	-40°C to +85°C	+5 V	32-Lead TQFP	SU-32-2
AD5764RCSUZ <sup>1</sup>	Quad 16-Bit DAC	±1 LSB Max	-40°C to +85°C	+5 V	32-Lead TQFP	SU-32-2
AD5764RCSUZ-REEL7 <sup>1</sup>	Quad 16-Bit DAC	±1 LSB Max	-40°C to +85°C	+5 V	32-Lead TQFP	SU-32-2

<sup>1</sup> Z = RoHS Compliant Part.