

## AD293/AD294

### FEATURES

#### High Common-Mode Voltage:

AD293  $\pm 2500\text{V}$  peak max, cont.

AD294  $\pm 3500$  peak max, cont.;  $\pm 8000\text{V}$  peak max Pulse

Nonlinearity:  $\pm 0.05\%$  max (AD293B)

Adjustable Input & Output Gain:  $1\text{V/V}$  to  $1000\text{V/V}$

Meets UL Std 544 Leakage:  $2.0\mu\text{A}$  max @  $115\text{V}$  ac,  $60\text{Hz}$

### APPLICATIONS

Off Ground Signal Measurement  
Industrial Control  
Nuclear Instrumentation  
High Voltage Protection for Data Acquisition Systems  
Medical Diagnostic and Patient Monitoring Equipment

### GENERAL DESCRIPTION

The AD293/AD294 are low cost, high performance isolation amplifiers designed for accurate processing of low level, industrial sensor or biomedical signals, with true galvanic isolation from high common-mode voltages, transients and lethal ground fault currents. The true hybrid architecture of the AD293/AD294 includes a proprietary hybrid magnetic transformer, all housed in a low profile (0.3") epoxy sealed, 40-pin ceramic package.

The AD293 features a maximum nonlinearity of 0.1% (AD293A) or 0.05% (AD293B) and maximum common-mode voltage isolation of either 2500V peak (continuous ac or dc) or 2500V rms (ac 60Hz, 1 minute). The AD294A provides a maximum nonlinearity of 0.1% and maximum common-mode voltage isolation of 3500V peak (continuous ac, dc) and common-mode voltage pulse (defibrillator) or transient protection of  $\pm 8000\text{V}$  peak.

In medical applications requiring patient isolation from lethal ground fault currents, the AD293/AD294 meet UL STD 544 leakage requirements by guaranteeing a maximum leakage current of  $2\mu\text{A}$  rms (115V, 60Hz).

All versions provide small signal ( $-3\text{dB}$ ) frequency response of 2.5kHz and a full power response of 200Hz (at gain of  $1\text{V/V}$ ). Both the input and output sections of the AD293/AD294 are gain programmable, allowing the user to tailor the amplifier to meet an application requirement.

### AD293/AD294 FUNCTIONAL BLOCK DIAGRAM

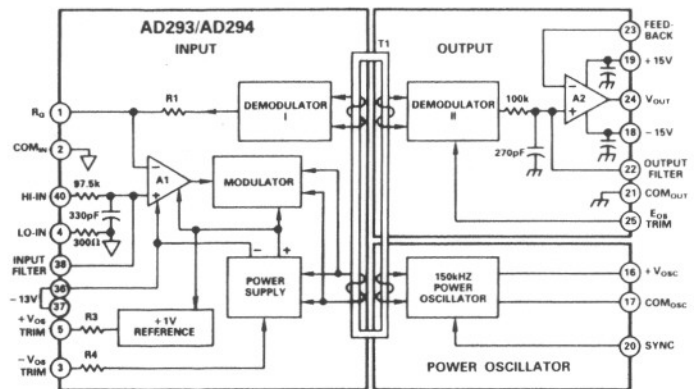

### WHERE TO USE THE AD293/AD294

**Industrial:** In process control systems, high CMV instrumentation and multi-channel computer interface systems, the AD293/AD294 provide guaranteed protection against high transient voltages, lethal ground fault currents and high common-mode voltages.

**Medical:** In biomedical and patient monitoring equipment such as ECG recorders, diagnostic systems and blood pressure monitors, the AD294A offers protection from lethal ground fault currents as well as 8kV peak defibrillator pulse inputs.

Low level signal recording and monitoring is achieved with the AD294A's low input noise ( $10\mu\text{V}$  p-p @  $G = 100\text{V/V}$ ) high CMR (100dB min @ 60Hz).

### DESIGN FEATURES AND USER BENEFITS

**Adjustable Gain:** Gain can be selected at either the input, output, or both. Thus, circuit response can be tailored to the user's application. The input gain can be selected from  $1\text{V/V}$  to  $100\text{V/V}$  with a single resistor. The output gain can be selected from  $1\text{V/V}$  to  $10\text{V/V}$  with or without compensation. The AD293/AD294 provides the user with flexibility for circuit optimization without requiring external active components.

**Buffered Output:** The AD293/AD294 prevent inaccuracies related to low impedance loads by providing an uncommitted output amplifier capable of supplying  $\pm 10\text{V}$  @  $5\text{mA}$  min.

# SPECIFICATIONS (typical @ + 25°C, & V<sub>S</sub> = 15V unless otherwise noted)

MODEL	AD293A	AD293B	AD294A	PIN DESIGNATIONS																																															
<b>GAIN</b>				<table border="1"> <thead> <tr> <th>PIN</th> <th>FUNCTION</th> <th>PIN</th> <th>FUNCTION</th> </tr> </thead> <tbody> <tr> <td>1</td> <td>R<sub>G</sub></td> <td>40</td> <td>HI-IN</td> </tr> <tr> <td>2</td> <td>COM<sub>IN</sub></td> <td></td> <td></td> </tr> <tr> <td>3</td> <td>-V<sub>OS</sub> TRIM</td> <td>38</td> <td>INPUT FILTER</td> </tr> <tr> <td>4</td> <td>LO-IN</td> <td>37</td> <td>-13V</td> </tr> <tr> <td>5</td> <td>+V<sub>OS</sub> TRIM</td> <td>36</td> <td>-13V</td> </tr> <tr> <td>16</td> <td>+V<sub>OSC</sub></td> <td>25</td> <td>E<sub>OS</sub> TRIM</td> </tr> <tr> <td>17</td> <td>COM<sub>OSC</sub></td> <td>24</td> <td>V<sub>OUT</sub></td> </tr> <tr> <td>18</td> <td>-15V</td> <td>23</td> <td>FEEDBACK</td> </tr> <tr> <td>19</td> <td>+15V</td> <td>22</td> <td>OUTPUT FILTER</td> </tr> <tr> <td>20</td> <td>SYNC</td> <td>21</td> <td>COM<sub>OUT</sub></td> </tr> </tbody> </table>				PIN	FUNCTION	PIN	FUNCTION	1	R <sub>G</sub>	40	HI-IN	2	COM <sub>IN</sub>			3	-V <sub>OS</sub> TRIM	38	INPUT FILTER	4	LO-IN	37	-13V	5	+V <sub>OS</sub> TRIM	36	-13V	16	+V <sub>OSC</sub>	25	E <sub>OS</sub> TRIM	17	COM <sub>OSC</sub>	24	V <sub>OUT</sub>	18	-15V	23	FEEDBACK	19	+15V	22	OUTPUT FILTER	20	SYNC	21	COM <sub>OUT</sub>
PIN	FUNCTION	PIN	FUNCTION																																																
1	R <sub>G</sub>	40	HI-IN																																																
2	COM <sub>IN</sub>																																																		
3	-V <sub>OS</sub> TRIM	38	INPUT FILTER																																																
4	LO-IN	37	-13V																																																
5	+V <sub>OS</sub> TRIM	36	-13V																																																
16	+V <sub>OSC</sub>	25	E <sub>OS</sub> TRIM																																																
17	COM <sub>OSC</sub>	24	V <sub>OUT</sub>																																																
18	-15V	23	FEEDBACK																																																
19	+15V	22	OUTPUT FILTER																																																
20	SYNC	21	COM <sub>OUT</sub>																																																
Range	1 to 1000V/V	*	*																																																
Formula (Input)	$G_{IN} = \left(1 + \frac{100k}{R_G}\right)$ ; R <sub>G</sub> ≥ 1kΩ; G <sub>IN</sub> max = 100																																																		
(Output)	$G_{OUT} = \left(1 + \frac{R_A}{R_B}\right)$ ; 1 ≤ G <sub>OUT</sub> ≤ 10; G <sub>OUT</sub> max = 10																																																		
<b>Deviation from Formula</b>																																																			
G = 1	± 1.0%	*	*																																																
G > 1	± 3.0%	*	*																																																
vs. Temperature (-25°C to +85°C) <sup>1,2</sup> (Gain = 1)	± 60ppm/°C max	*	*																																																
(Gain > 1)	± 120ppm/°C max	*	*																																																
Nonlinearity (± 5V swing) <sup>2</sup>	± 0.1% max	± 0.05% max	*																																																
<b>INPUT VOLTAGE RATINGS</b>																																																			
Linear Differential Range	± 10V min	*	± 5V min																																																
Max Safe Differential Input																																																			
Continuous	120V rms max	*	*																																																
1 Minute	240V rms max	*	*																																																
Max CMV (Inputs to Outputs)																																																			
Continuous (ac or dc)	± 2500V peak	*	± 3500V peak																																																
ac, 60Hz, 1 minute Duration	2500V rms	*	3500V rms																																																
Pulse, 10ms Duration, 1 pulse/10 sec	—	—	± 8000V peak																																																
CMR (60Hz), G = 10V/V																																																			
R <sub>S</sub> ≤ 1kΩ Balanced Source Impedance	108dB	*	*																																																
R <sub>S</sub> = 1kΩ Source Impedance Imbalance	100dB min	*	*																																																
R <sub>S</sub> ≤ 5kΩ Balanced Source Impedance	—	—	100dB																																																
R <sub>S</sub> ≤ 5kΩ Source Impedance Imbalance	—	—	95dB min																																																
Leakage Current, Input to Output																																																			
( <i>α</i> 115V ac, 60Hz)	2μA rms max	*	*																																																
Input Impedance, G = 1																																																			
Differential	150pF    10 <sup>8</sup> Ω	*	*																																																
Overload	100kΩ	*	*																																																
Common Mode	30pF    (5 × 10 <sup>10</sup> Ω)	*	*																																																
Input Bias Current																																																			
Initial ( <i>α</i> + 25°C)	2nA (5nA max)	*	*																																																
vs. Temperature	20pA/°C	*	*																																																
Input Noise																																																			
Voltage																																																			
0.05Hz to 100Hz	10μV p-p	*	*																																																
10Hz to 1kHz	5μV rms	*	*																																																
Current																																																			
0.05Hz to 100Hz	50pA p-p	*	*																																																
<b>FREQUENCY RESPONSE</b>																																																			
Small Signal (-3dB) G = 1V/V to 100V/V	2.5kHz	*	*																																																
Full Power, 20V p-p Output (10V p-p AD294)																																																			
G = 1V/V (G <sub>IN</sub> = 1V/V, G <sub>OUT</sub> = 1V/V)	200Hz	*	*																																																
G = 100V/V (G <sub>IN</sub> = 100V/V, G <sub>OUT</sub> = 1V/V)	100Hz	*	*																																																
G = 10V/V (G <sub>IN</sub> = 1V/V, G <sub>OUT</sub> = 10V/V)	1.5kHz	*	*																																																
Slew Rate	9.1V/ms	*	*																																																
<b>OFFSET VOLTAGE, REFERRED TO INPUT</b>																																																			
Initial, ( <i>α</i> + 25°C, max)	$\left(\pm 3 \pm \frac{22}{G_{IN}}\right)$ mV	*	*																																																
vs. Temperature	$\left(\pm 3 \pm \frac{150}{G_{IN}}\right)$ μV/°C		$\left(\pm 10 \pm \frac{300}{G_{IN}}\right)$ μV/°C max																																																
(0 to + 70°C)																																																			
(- 25°C to + 85°C) max	$\left(\pm 10 \pm \frac{500}{G_{IN}}\right)$ μV/°C max	$\left(\pm 5 \pm \frac{250}{G_{IN}}\right)$ μV/°C	$\left(\pm 10 \pm \frac{1000}{G_{IN}}\right)$ μV/°C																																																
vs. Supply Voltage	$\left(\pm 0.01 \pm \frac{3}{G_{IN}}\right)$ mV/V	*	*																																																
<b>RATED OUTPUT</b>																																																			
Voltage, 2kΩ Load	± 10V min	*	*																																																
Output Impedance	< 1Ω	*	*																																																
Output Ripple, (dc to 100kHz) Bandwidth	4mV p-p	*	*																																																
<b>POWER SUPPLY<sup>3</sup></b>																																																			
Voltage, Rated Performance	± 15V dc ± 3%	*	*																																																
Voltage, Operating <sup>4</sup>	± 12V dc ± 18V dc	*	*																																																
Current, Quiescent (V <sub>S</sub> = ± 15V)	+ 1mA, - 1mA	*	*																																																
(+ V <sub>OSC</sub> = + 15V)	+ 11mA	*	*																																																
<b>ISOLATED POWER</b>																																																			
	- 13V dc ( <i>α</i> 200μA)	*	*																																																
<b>TEMPERATURE RANGE</b>																																																			
Rated Performance	- 25°C to + 85°C	*	*																																																
Operating	- 40°C to + 100°C	*	*																																																
<b>CASE DIMENSIONS</b>																																																			
	2.64" × 0.86" × 0.35"	*	*																																																
<b>PACKAGE OPTION<sup>5</sup></b>																																																			
	HY20A	*	*																																																

**NOTES**

\*Specifications same as AD293A.

<sup>1</sup>Gain temperature drift is specified as a percentage of output signal level (*α* 10V pk-pk).

<sup>2</sup>Gain nonlinearity is specified as a percentage of 10V pk-pk output span.

<sup>3</sup>Recommended power supply, ADI Model 904, + 15V (*α* 50mA output).

<sup>4</sup>Output Swing = 0.66V<sub>S</sub>.

<sup>5</sup>See Section 19 for package outline information.

Specifications subject to change without notice.

# Understanding the Isolation Amplifier Performance

**Synchronization:** The unique hybrid transformer design and low power consumption of the AD293/AD294 result in very low RFI (carrier) levels which make it unnecessary to synchronize adjacent amplifiers in a multi-channel application, since "beat frequency" and cross talk caused by intermodulation are virtually eliminated.

If desired by the user, multiple AD293/AD294's may be synchronized by connecting a 0.0015μF capacitor in series with each amplifier's SYNC terminal (pin 20) and driving them with a TTL compatible, 150kHz (± 10%) source. SYNC input impedance for each amplifier is approximately 8kΩ.

**High Reliability:** The AD293/AD294 are designed specifically to provide highly reliable operation in extremely harsh environments. These devices are available in epoxy sealed ceramic packages which use hybrid techniques and incorporate a revolutionary new hybrid magnetic transformer eliminating traditional wire wound methods.

## INTERCONNECTIONS AND SHIELDING TECHNIQUE

To preserve the high CMR performance of the AD293/AD294, care must be taken to keep the capacitance balanced about the input terminals. Use twisted shielded cable, for the input signal, to reduce inductive and capacitive pickup. The cable shield should be connected to the common mode signal source and as close as possible to their respective terminal connections so pick-up can be minimized (shown in Figure 1).

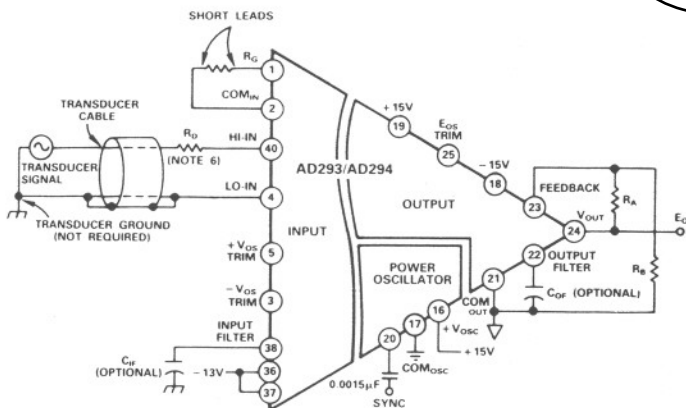

### NOTES:

1. GAIN RESISTORS  $R_G$ ,  $R_A$  AND  $R_B$ , 1% 50ppm/°C METAL FILM TYPE.
2. INPUT GAIN =  $1 + \frac{100k}{R_G}$ ;  $R_G \geq 1k$ ; MAX INPUT GAIN = 100V/V.
3. OUTPUT GAIN =  $1 + \frac{R_A}{R_B}$ ;  $1 \leq$  OUTPUT GAIN  $\leq 10$ .  
FOR OUTPUT GAIN > 1, A 33pF MAY BE REQUIRED ACROSS  $R_A$ .
4.  $C_{if} = \frac{1}{2\pi f(9.75 \times 10^4)}$  FARADS - 330pF.
5.  $C_{of} = \frac{1}{2\pi f(10^5)}$  FARADS - 270pF.
6.  $R_D$  IS REQUIRED ONLY FOR THE AD294 TO PROVIDE PROTECTION AGAINST DEFIBRILLATOR PULSES. USE TWO 240kΩ 1/2 WATT RESISTORS. WHEN MOUNTING, PLACE THEM IN SERIES AND AWAY FROM THE PCB.

Figure 1. Basic Isolator Interconnection

## THEORY OF OPERATION

The AD293/AD294 attribute their outstanding performance to the innovation of a hybrid magnetic ceramic transformer T1 (shown in the block diagram of Figure 2). Windings are screened on two ceramic alumina substrates which are placed together separated by a ceramic isolation barrier. Then an E-core is carefully fitted around the substrates to complete the transformer.

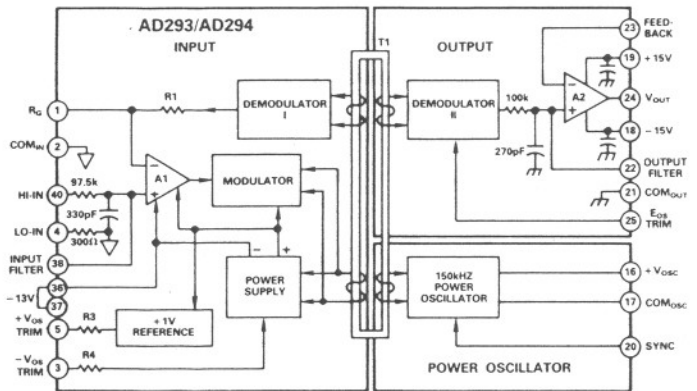

Figure 2. AD293/AD294 Block Diagram

Incorporating the carrier isolation technique, both power and signals are transferred between the amplifier's input stage and output circuitry via T1. The input signal is filtered and appears at the noninverting input of amplifier A1. This signal is then amplified by A1, with its gain (1V/V to 100V/V) determined by the value of resistance connected between  $R_G$  and  $COM_{IN}$ . The output of A1 is modulated, carried across the isolation barrier by signal transformer T1, and demodulated. The demodulator output voltage is filtered and then buffered by A2. Output gain (1V/V to 10V/V) and frequency compensation is determined by the value of resistance and capacitance selected between A2's feedback,  $V_{OUT}$ , and  $COM$  terminals. The 150kHz asymmetric square wave power oscillator drives the primary windings of transformer T1. The secondary windings of T1 then energizes the input power supply and drives both the modulator and demodulator.

## INTERELECTRODE CAPACITANCE AND TERMINAL RATINGS

**Capacitance:** Interelectrode terminal capacitance effects are developed from stray capacitance that couple the input and output terminals together. The difference shown in Figure 3 between the AD293 and AD294 is a result of the separate transformer designs. Each terminal capacitance is shunted by leakage resistance exceeding  $3.4 \times 10^9 \Omega$ .

**Terminal Ratings:** CMV performance is given in peak pulse and continuous ac or dc peak ratings. Continuous peak ratings apply from dc up to the normal full power response frequencies. Figure 3 illustrates the AD293/AD294 ratings between terminals.

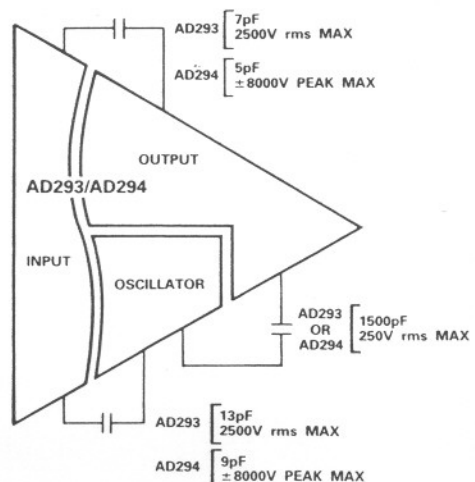

Figure 3. Interelectrode Capacitance and Terminal Ratings

## OFFSET AND GAIN TRIM PROCEDURES

The calibration procedure, shown in Figure 4, illustrates the recommended techniques which can be used to minimize output error. In this example, the output span is +10V to -10V and gain = 100V/V ( $G_{IN} = 10V/V$ ;  $G_{OUT} = 10V/V$ ).

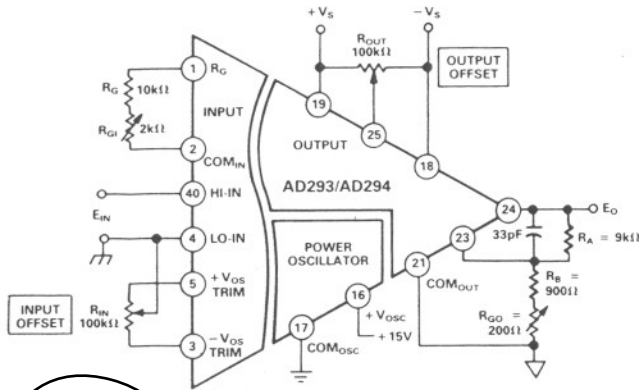

Figure 4. Recommended Offset & Gain Adjustments

### Offset Adjustment

1. Set  $G_{OUT} = 1V/V$  by disconnecting  $R_B$  from COM.
2. Apply  $E_{IN} = 0$  volts and adjust  $R_{IN}$  for  $E_O = 0$  volts.
3. Connect  $R_B$  to COM.
4. Adjust  $R_{OUT}$  for  $E_O = 0$  volts.

### Gain Adjustment

5. Set  $G_{OUT} = 1V/V$  by disconnecting  $R_B$  from COM.
6. Apply  $E_{IN} = +1.000V$  and adjust  $R_{GI}$  for  $E_O = +10.000V$ .
7. Connect  $R_B$  to COM.
8. Apply  $E_{IN} = +0.100V$  and adjust  $R_{GO}$  for  $E_O = +10.000V$ .

## LEAKAGE CURRENT LIMITS

The low coupling capacitance between input and output yields a ground leakage current of less than  $2\mu A$  rms of 115V ac, 60Hz in the AD293/AD294 which meet standards established by UL STD 544.

For medical applications, the AD293/AD294 are designed to improve on patient safety current limits proposed by the F.D.A., U.L., A.A.M.I. and other regulatory agencies.

In patient monitoring equipment, such as ECG recorders, the AD293/AD294 will provide adequate isolation without exposing the patient to potentially lethal microshock hazards. With the use of passive components for input protection, this design limits input fault currents even under amplifier failure conditions.

## PERFORMANCE CHARACTERISTICS

**Phase vs. Frequency:** The phase vs. frequency responses for the AD293/AD294, is shown in Figure 5. The bandwidth is sufficient for the majority of isolation applications where accurate signal measurements must be made in the presence of noise and high common-mode voltages.

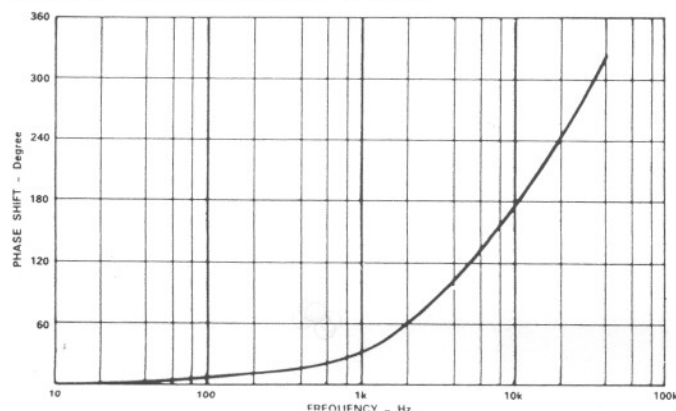

**Common-Mode Rejection:** Input-to-output CMR is dependent on source impedance imbalance, input signal frequency and amplifier gain. CMR is rated at 60Hz and  $1k\Omega$  (AD293)/ $5k\Omega$  (AD294) source impedance imbalance at a gain of 1V/V. Figure 6 illustrates the CMR vs. frequency characteristics for the AD293/AD294. CMR approaches 144dB at dc with source impedance as high as  $1k\Omega$  (AD293)/ $5k\Omega$  (AD294). Figure 7

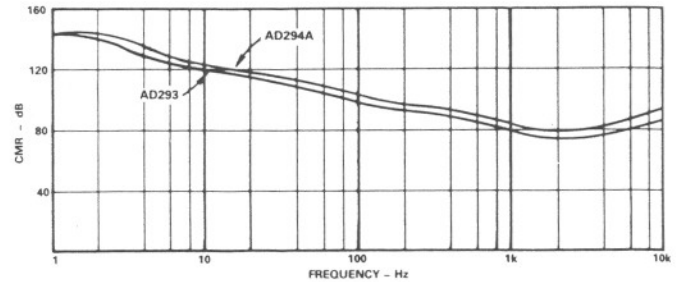

Figure 6. Typical AD293/AD294 - CMR vs. Frequency

illustrates the effect of source impedance imbalance on CMR performance at 60Hz for various gain settings. CMR is maintained greater than 60dB for source imbalances up to  $100k\Omega$ . As shown, increasing isolator gain increases CMR.

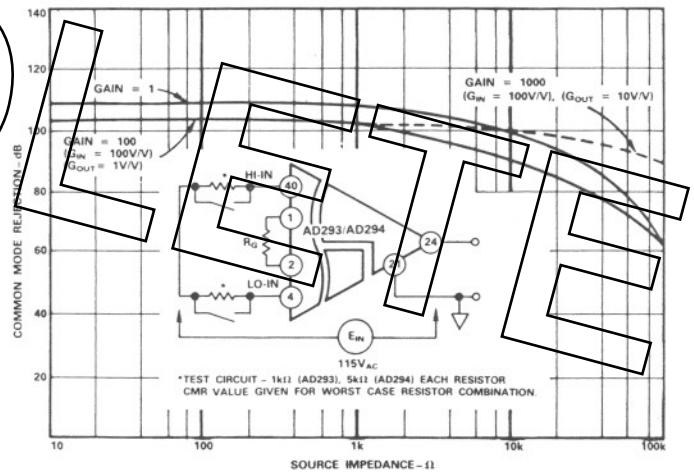

Figure 7. Typical AD293/AD294 - CMR vs. Source Impedance

**Input Voltage Noise:** Voltage noise, referred to input, is dependent on gain and bandwidth as illustrated in Figure 8. RMS voltage noise in a bandwidth from 10Hz to 100kHz is shown on the horizontal axis. The peak-to-peak value is derived by multiplying the rms value @  $F = 100Hz$  ( $0.75\mu V$  rms) by 6.6.

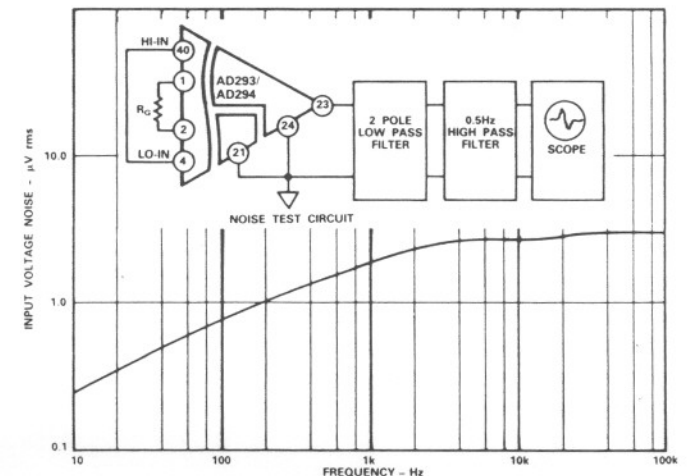

Figure 8. Typical AD293/AD294 - Input Noise vs.



For applications requiring improved noise performance, additional low pass filters may be placed at either the input or output sections to selectively roll-off noise and undesired signals beyond the bandwidth of interest.

### Gain Nonlinearity vs. Gain

Figure 9, shows the AD293/AD294 gain nonlinearity vs. gain as a function of output gain. As input gain is increased, gain nonlinearity increases. Conversely, as output gain is increased to ten, gain nonlinearity decreases.

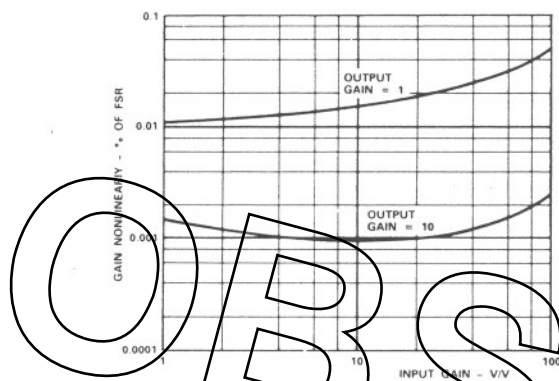

Figure 9. Typical AD293/AD294 - Gain Nonlinearity vs. Gain as a Function of Output Gain

### Full Power Bandwidth vs. Gain

Figure 10 shows the full power bandwidth vs. gain with the input and output gain curves shown separately. As shown, the full power bandwidth with gain provided at the input is typically 200Hz. But with gain provided only at the output, the full power bandwidth approaches the small signal bandwidth.

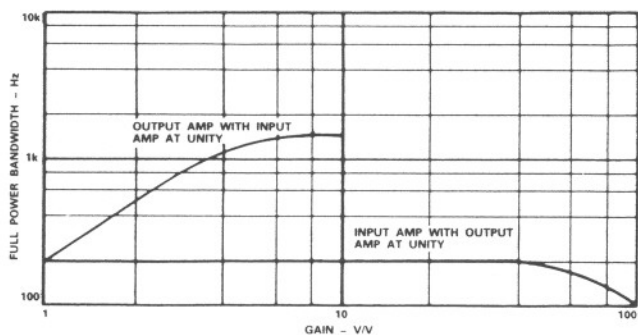

Figure 10. Typical AD293/AD294 - Full Power Bandwidth vs. Gain

### Gain Nonlinearity vs. Output Swing

The gain nonlinearity vs. output swing, for the AD293/AD294, is illustrated in Figure 11. As shown, increasing either the input

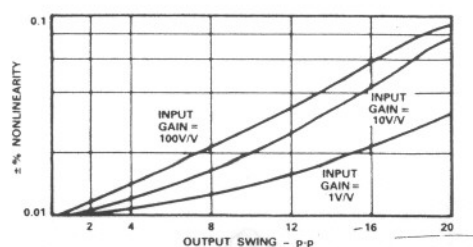

Figure 11. Typical AD293/AD294 - Gain Nonlinearity vs. Output Swina

gain or the output swing will cause the gain nonlinearity to increase if the output gain is held to 1V/V.

### OPTIMIZING THE AD293/AD294

The AD293/AD294 can be optimized for many applications as shown by the performance charts on the previous page. Gain and filtering can be implemented on both the input and output stages while providing true galvanic isolation. Provisions for an additional two poles of filtration are also available without the addition of external operational amplifiers. Due to their low power consumption and novel transformer design, the beat frequency problem normally associated with adjacent isolation amplifiers is eliminated. A sync terminal is provided for applications where ultra-sensitive circuitry might interpret the isolator carrier frequency.

### SELECTING GAIN

The AD293/AD294 contain both input and output amplifiers (see Figures 1 and 2), the gains of which can be set independently. The selection of a particular combination tailors isolator properties to the application, minimizes errors, and optimizes frequency response.

Nonlinearity is the deviation of response from a straight line. This error arises from slight differences in responses of the input demodulator I and demodulator II, their respective transformer windings responses, and rectification of carrier signal in the input stage due to large signal amplitudes in this section. Hence, linearity is best obtained by raising output gain and lowering input gain.

Gain errors are deviations in slope from the predicted gain equation. Gain errors are attributable to the difference in gain between demodulators I and II. These errors are quite small, due to the highly predictable and uniform nature of the thick-film transformer. The gain drift of this portion of gain error is also small. Since this gain error source dominates at unity gain, the unity gain temperature coefficients of these units is very small. As input gain is taken, errors arise due to the inaccuracies of the internal feedback resistor R1, and user selected R<sub>G</sub>. Failure of these resistors to temperature track introduces a gain TC. R1 is trimmed within  $\pm 3\%$  and has a TC of  $\pm 100\text{ppm}/^\circ\text{C}$ . Since the temperature coefficient of R1 is not user controllable, best gain TC at low gains is favored by taking output gain. The output stage also contributes gain error only when gain is taken. Here, both the feedback and gain resistors are user supplied and can be made as accurate as desired.

Offset errors are apparent both in the input stage and in the transformer-output stage combination. Provisions are available to eliminate these initial offset errors at both the input and output stages through trim potentiometers. These errors also have temperature dependence where at unity gain, output offset drift dominates. Taking output gain multiplies output drift by the gain taken. Taking input gain helps dilute output stage offset drift and is recommended where offset drift is to be minimized.

Errors due to small signal and large signal bandwidth limitations can also be optimized in the AD293/AD294. Small signal bandwidth is limited by lack of gain as frequency is raised, a condition caused by the necessity to limit bandwidth internally to preserve stability in the A1, modulator, input demodulator loop. The input stage contains most of the small signal bandwidth limitations thus, taking input gain limits small signal bandwidth (see Figure 10). The demodulators limit slew rate and large signal bandwidth. Apparent slew rate at the isolator output is

multiplied by gain taken in the output stage. With maximum gain taken in the output stage, large signal bandwidth for moderate swings approaches small signal bandwidth (shown in Figure 10). Thus applying input gain limits bandwidth while output gain enhances it.

### FILTERING

With the AD293/AD294, the addition of filtering can be implemented in a number of different configurations without the use of external operational amplifiers. Capacitors can be placed in series with the input or output terminals or configured in combination with the gain setting resistors to tailor performance. An input filter terminal and an output filter terminal are provided for user selectable filtration. Characteristics are determined by the formulas shown in Figure 1.

### REDUCING NORMAL-MODE VOLTAGE

A prime isolator function is the rejection of common-mode signals. The extremely high input to output resistance of isolators allows excellent rejection of dc common-mode voltages. As frequency rises, the small capacitance across the isolation barrier causes an ac common-mode current to flow through that barrier, which is proportional to applied common-mode voltage, frequency and barrier capacitance. Since the isolation mechanism (transformer T1) is more intimately connected to the input low terminal than the input high terminal, the bulk of common mode

current flows through the input low terminal. Any resistance in series with the input source and the input low terminal then develops a normal-mode voltage, which may constitute objectionable interference.

An isolator cannot separate normal-mode interference from the desired signal without help, but interference can be rejected in several ways.

Conversion of common-mode current to normal-mode voltage can be reduced by minimizing resistance in the input low lead. In the AD293/AD294 CMR is enhanced and input trimming sacrificed by returning the input signal to pin 2. With known stable source resistances common-mode current to normal-mode voltage conversion can also be cancelled as shown in Figure 13.

### ISOLATED INDUSTRIAL APPLICATIONS

As illustrated in Figure 14, the AD293 can be applied where differential signal sources are used such as an isolated strain gauge. With a third wire connected to the common-mode potential of that source, a common-mode current is forced to flow through the third wire and through the isolation barrier; thus, sparing the differential input wires the necessity of conducting the common-mode current. In this manner, the isolator is responsive to only the differential inputs while ignoring the passage of common-mode currents. Input gain is selected via  $R_G$  and determined by the input gain formula.

### MEDICAL APPLICATIONS

In medical applications, a good connection to the patient, even on the third wire cannot be guaranteed due to electrode resistance to and through the skin. Illustrated in Figure 12 is a medical front end with right leg drive powered by the AD294A. Here the common-mode drive amplifier helps force common-mode current to flow in the third wire in preference to the differential input wires. The FET input has low noise current to avoid development of voltage noise in the input protection resistors.

These resistors protect the input from defibrillator pulses with the AD294A having the capability of withstanding an 8kV pulse. The patient is also protected from fault currents due to input component failure. It is necessary to connect the third wire to establish the input common-mode level. If not connect the input common-mode level, with respect to common of the input section power supplies, will cause the isolator to drift out of its linear range. Layout is also very important, both for common-mode rejection and isolation.

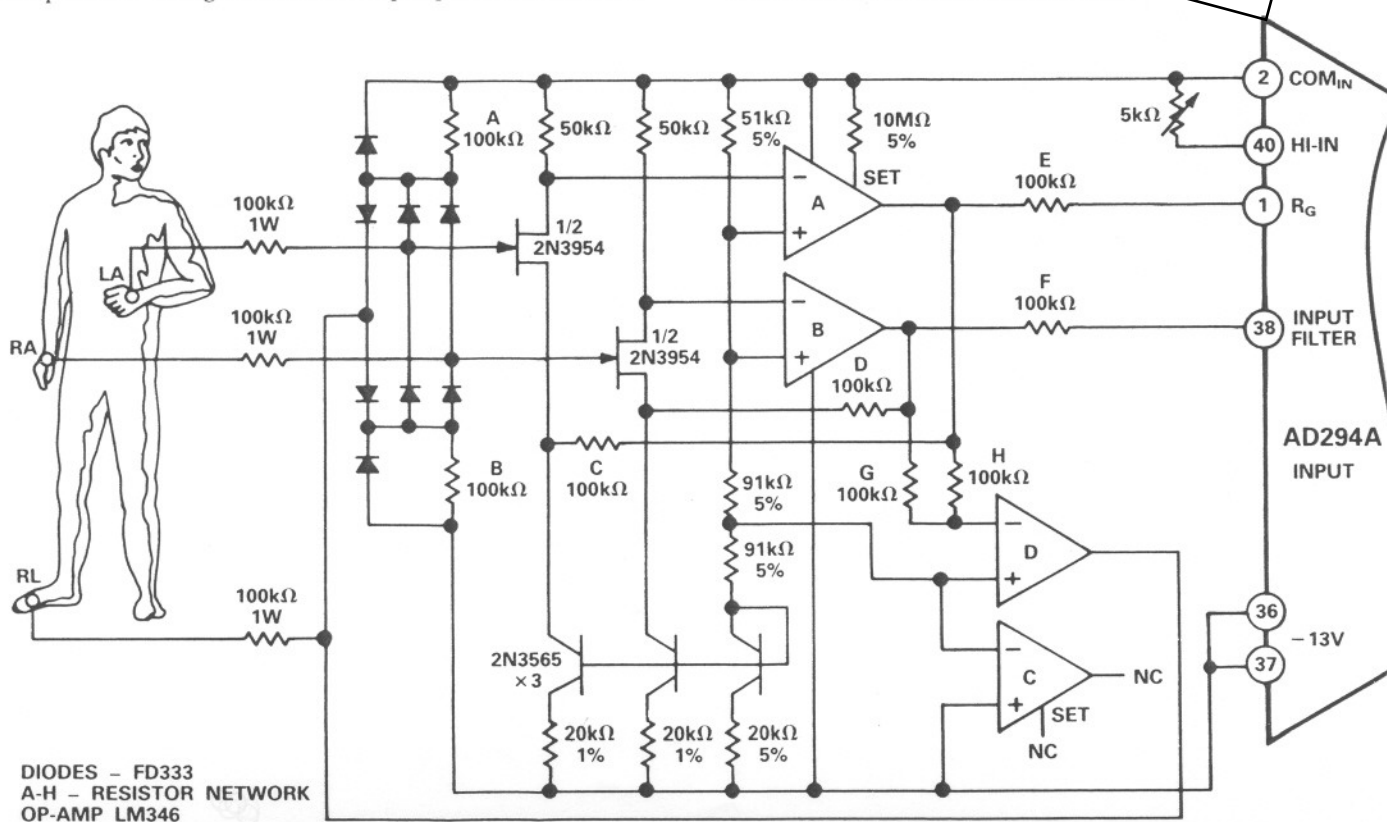

Figure 12. Multilead Medical Application Using the AD294A with Right Leg Drive

AD293 conditions the 0V to 10V input signal and provides a proportional voltage at the isolator's output. Then the circuitry shown converts it into a 4 to 20mA current, which in turn, may be applied to the loop load  $R_L$ .

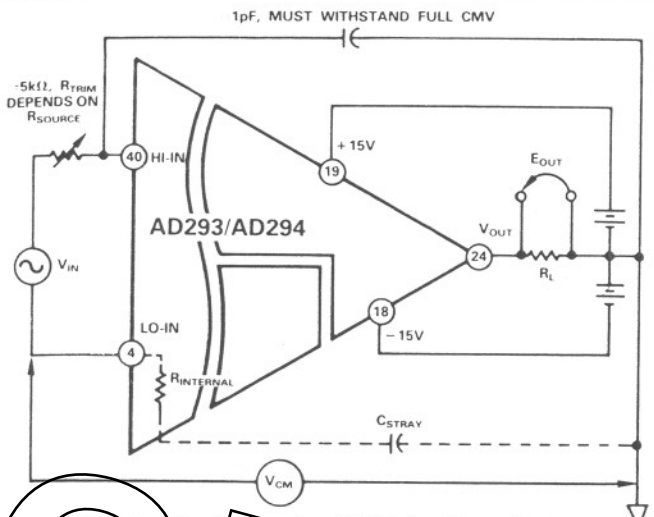

Figure 13. Improving CMR by Cancellation

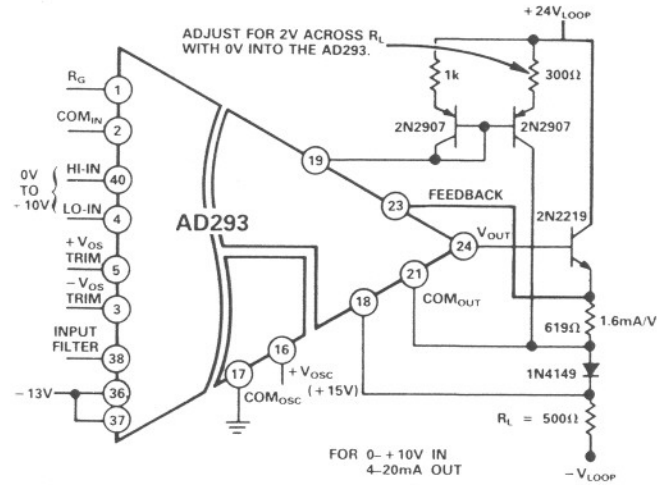

Figure 15. Isolated Current Loop Interface

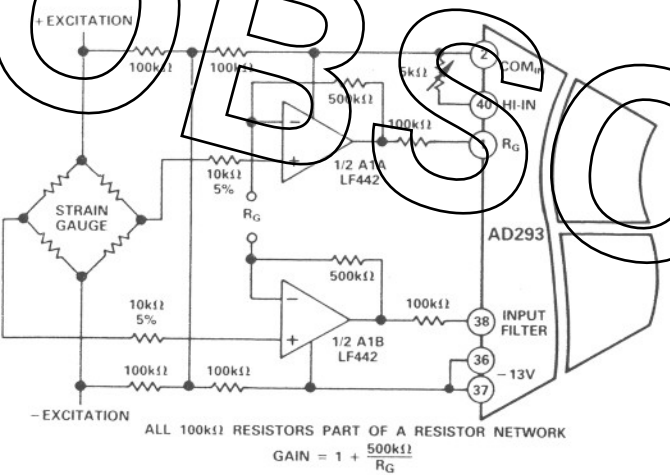

Figure 14. Isolated Strain Gauge Using Front End of AD293

**TEMPERATURE MEASUREMENT AND COLD JUNCTION COMPENSATION**

Illustrated in Figure 16, the AD293 can be used for isolated temperature measurements while providing cold junction compensation. With the circuitry connected as shown, the LM334 must be thermally connected to the cold junction terminal for an accurate temperature measurement to be made of this terminal. In this configuration, accurate temperature measurements using the industry's popular J type thermocouple can be made. For example, assume 1V out of the AD293 at 100°C. From the ANSI tables, the output voltage of a J thermocouple at 100°C is 0.005268V. Set the gain of the AD293 at 1V/0.005268V = 189.8,  $R_G = 530\Omega$ . With the thermocouple junction open, set the voltage between points A and B to 0.015V by adjusting the 500Ω pot. Connect a voltage reference source in place of the thermocouple. Set its output to zero. Set the output of the AD293 to zero by adjusting the 100Ω pot. Set the reference source to 0.005268V. The output of the AD293 should read 1V.

**CURRENT LOOP INTERFACE**

Illustrated in Figure 15, the AD293 provides an isolated sensor interface that is compatible with standard 4-to-20mA current loops. Here high common-mode rejection and high common-mode voltage suppression are easily attained with the AD293. The

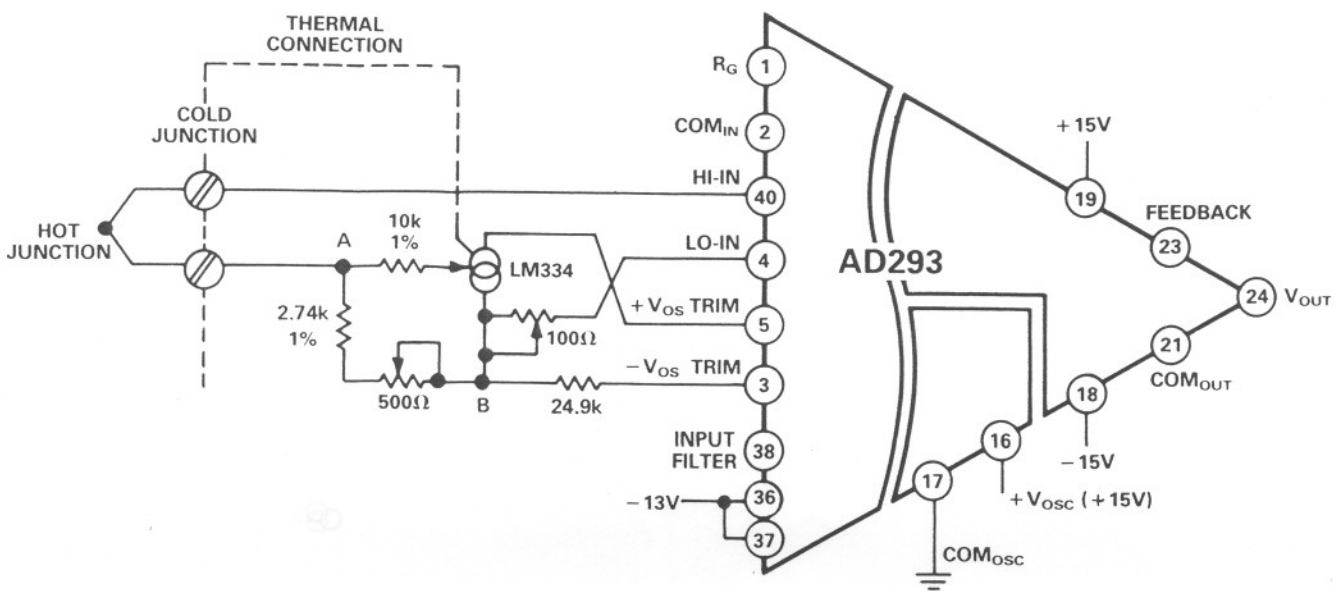

Figure 16. Temperature Measurement & Cold Junction Compensation

## DRIVING CAPACITIVE LOADS

For driving capacitive loads greater than 1000pF, compensation should be implemented as shown in Figure 17. Here a 100pF capacitor and 100Ω resistor are used to insure that the AD293 output stage remains stable. These components can also be changed to tailor frequency response to the particular application. The 100Ω resistor isolates the output of the AD293 while the 100pF provides response lead.

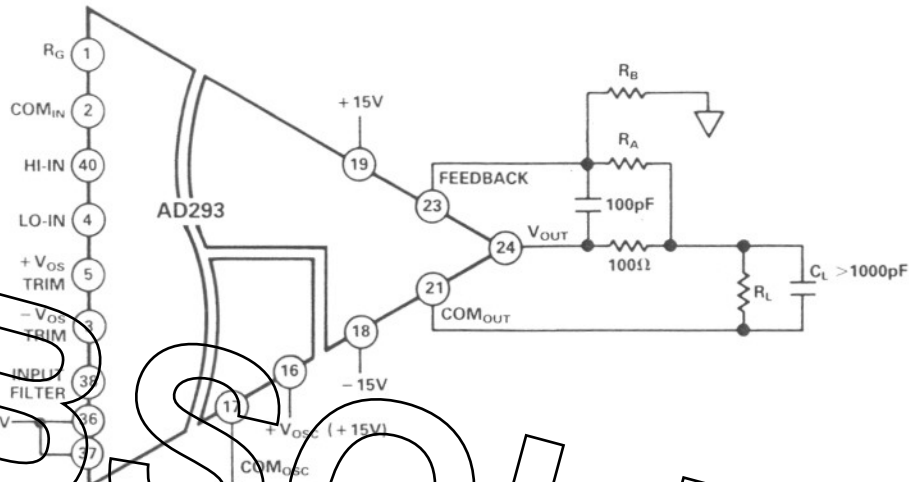

Figure 17. Driving Capacitive Loads

## INCREASING OUTPUT DRIVE CAPABILITY

For applications requiring increased output drive, Figure 18 illustrates a single solution. Here the output voltage of the AD293 is conditioned and applied to the drive circuitry.  $R_A$  will supply the output stage with unity gain as connected. For gain to be added to the output stage, connect  $R_B$  as shown. Output gain will be determined by the output equation previously stated in the specifications. For output gain  $> 1V/V$ ,  $C_O$  should also be implemented so output stability will be insured. With this output drive circuitry, 200Ω loads can be easily driven with  $\pm 10V @ 50mA$ .

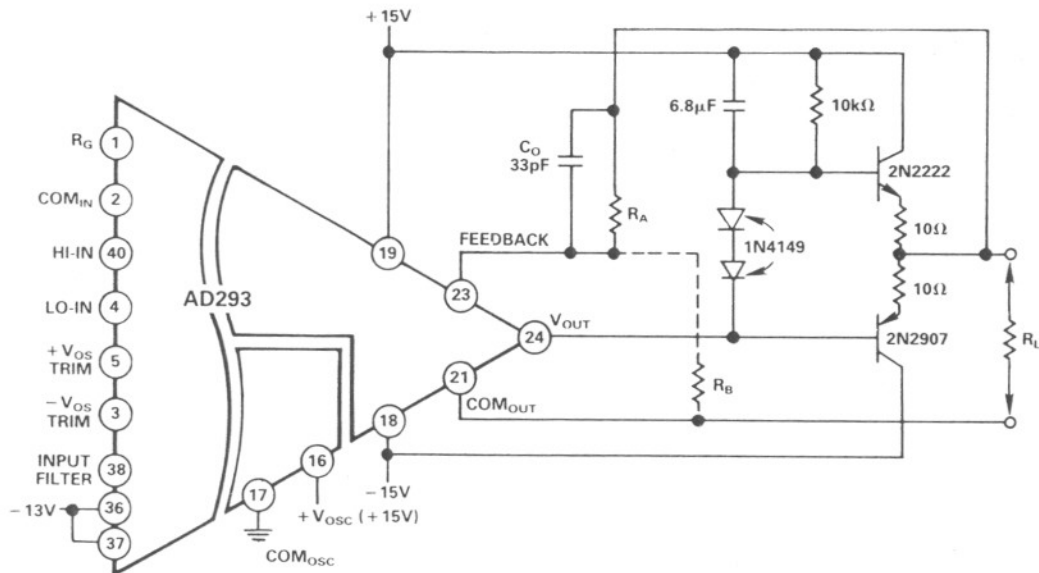

Figure 18. Increasing Output Drive Capability