

FEATURES
FOUR 192 kHz DACs/ADCs

Two independent stereo DAC/ADC pairs
 Simultaneous record of two stereo channels
 Simultaneous playback of two stereo channels
 Independent 8, 11.025, 16, 22.05, 32, 44.1,
 48, 88.2, 96, 176.4, and 192 kHz sample rates
 16, 20, and 24-bit resolution
 Selectable stereo mixer on outputs

S/PDIF OUTPUT

Supports 44.1, 48, 88.2, 96, 176.4, and 192 kHz sample rates
 16, 20, and 24-bit data; PCM, and AC3 formats
 Digital PCM gain control

DEDICATED AUXILIARY PINS

Stereo CD/auxiliary I/O port w/GND sense
 Stereo auxiliary/dock I/O port
 Mono out pin for internal speakers or telephony

ENHANCED FEATURES

Two stereo headphone amplifiers
 Microsoft Vista premium logo for notebook
 90 dB audio outputs, 85 dB audio inputs
 Internal 32-bit arithmetic for greater accuracy
 Impedance and presence detection on all jacks
 Three independent microphone bias pins
 Digital and analog PCBeep
 Three general-purpose digital I/O (GPIO) pins
 3.3 V analog and digital supply voltages
 Advanced power management modes
 48-lead, Pb-free LFCSP_VQ package

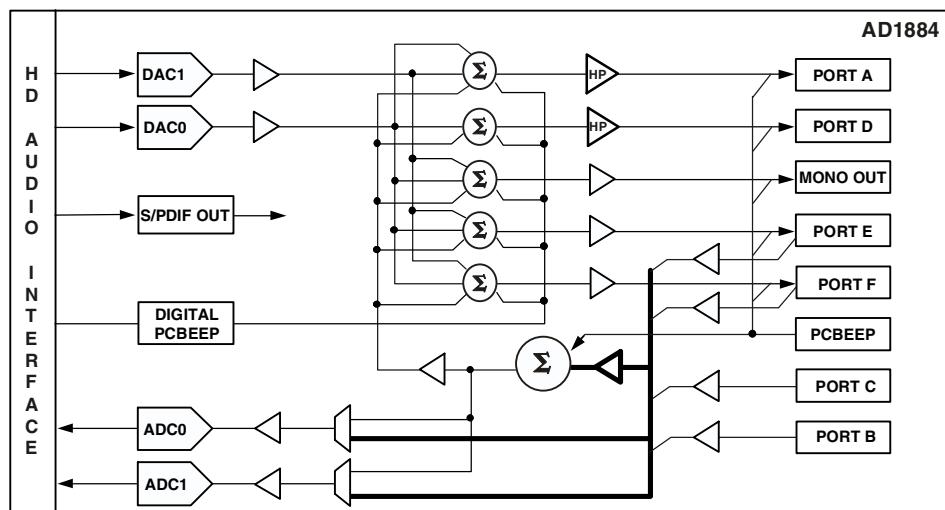

Figure 1. Functional Block Diagram

Rev. 0

Information furnished by Analog Devices is believed to be accurate and reliable. However, no responsibility is assumed by Analog Devices for its use, nor for any infringements of patents or other rights of third parties that may result from its use. Specifications subject to change without notice. No license is granted by implication or otherwise under any patent or patent rights of Analog Devices. Trademarks and registered trademarks are the property of their respective owners.

CONTENTS

General Description	3
Additional Information	3
Jack Configurations	3
AD1884 Specifications	4
Test Conditions	4
Performance	4
General Specifications	4
HD–Audio Link Specification	6
Power Down States	7
Absolute Maximum Ratings	8
ESD Sensitivity	8
Environmental Conditions	8
Pin Configuration and Function Descriptions	9
HD Audio Widgets	12
AD1884 HD Audio Parameters	13
Outline Dimensions	15
Ordering Guide	15

REVISION HISTORY

1/07–Rev 0: Initial version

GENERAL DESCRIPTION

The AD1884 family of audio codecs and SoundMAX® software provides superior high definition audio quality that exceeds Vista Premium for notebook performance. The AD1884 has four 192 kHz DACs, four 192 kHz ADCs, S/PDIF output, Digital Beep and analog PCBeep. These features make the AD1884 the right choice for notebook PCs that meet the Microsoft Vista premium performance specifications as well as desktop PCs that meet the Microsoft Vista Basic performance specifications.

The AD1884 is available in a 48-lead, Pb-free frame chip scale package in both reels and trays. See [Ordering Guide on Page 15](#).

ADDITIONAL INFORMATION

This data sheet provides a general overview of the AD1884 SoundMAX codec's architecture and functionality. Additional information on the AD1884 is available in the AD1884 Programmers Reference Manual. Please contact your local ADI sales representative for more information. For information on SoundMAX codecs and software see Analog Devices website at <http://www.analog.com/soundMAX>.

JACK CONFIGURATIONS

The guideline shown in [Table 1](#) should be used when selecting ports for particular functions. The symbols used in this table are defined as: LI = Line Level Input, LO = Line Level Output, HP = Output capable of driving headphone load, MIC = Input supports microphones with MIC bias and boost amplifier.

Table 1. Port Assignments

Port	HP	MIC	LO	LI
Port A	x		x	
Port B		x		x
Port C		x		x
Port D	x		x	
Port E		x	x	x
Port F			x	x
MONO_OUT			x	

AD1884

AD1884 SPECIFICATIONS

TEST CONDITIONS

Parameter	Test Condition
Temperature	25°C
Digital Supply	3.3 V
Analog Supply	3.3 V
MIC_BIAS_IN (via Low-Pass Filter)	5.0 V
Sample Rate f_s	48 kHz
Input Signal (Frequency Sine Wave)	1008 Hz
Amplitude for THD + N	-3.0 dB Full Scale
Analog Output Pass Band	20 Hz to 20 kHz
DAC	10 k Ω Output Load: Line Out Tests 32 Ω Output Load: Headphone Tests
ADC	0 dB Gain

PERFORMANCE

Parameter	Min	Typ	Max	Unit
Line Out Drive (10 k Ω loads—DAC to Pin)				
Total Harmonic Distortion (THD + N)		-84		dB
Dynamic Range (-60 dB in ref to f_s A-Weighted)		90		dB
Signal-to-Noise Ratio		90		dB
Headphone Drive (32 Ω loads—DAC to Pin)				
Total Harmonic Distortion (THD + N)		-74		dB
Dynamic Range (-60 dB in ref to f_s A-Weighted)		90		dB
Signal-to-Noise Ratio		90		dB
Microphone/Line In (Pin to ADC, Mic Boost = 0 dB)				
Total Harmonic Distortion (THD + N)		-78		dB
Dynamic Range (-60 dB in ref to f_s A-Weighted)		85		dB
Signal-to-Noise Ratio		85		dB

GENERAL SPECIFICATIONS

Parameter	Min	Typ	Max	Unit
DIGITAL DECIMATION AND INTERPOLATION FILTERS¹				
Pass Band - f_s (kHz) = 8 ~ 192	0		0.4 f_s	Hz
Pass-Band Ripple - f_s (kHz) = 8 ~ 192			± 0.005	dB
Stop Band - f_s (kHz) = 8 ~ 192	0.6 f_s			Hz
Stop-Band Rejection - f_s (kHz) = 8 ~ 192			-100	dB
Group Delay - f_s (kHz) = 8 ~ 192		20		1/ f_s
Group Delay Variation Over Pass Band		0		μ s
ANALOG TO DIGITAL CONVERTERS				
Resolution		24		Bits
Gain Error ² (Full-Scale Span Relative to Nominal Input Voltage)			± 10	%
Interchannel Gain Mismatch (Difference of Gain Errors)		± 0.2	± 0.5	dB
ADC Offset Error ¹			± 5	mV
ADC Crosstalk ¹				
Line Inputs (Input L, Ground R, Read R; Input R, Ground L, Read L)		-85		dB
Line_In to Other		-100	-80	dB

Parameter	Min	Typ	Max	Unit
DIGITAL TO ANALOG CONVERTERS				
Resolution		24		Bits
Gain Error ¹ (Full Scale Span Relative to Nominal Input Voltage)			±10	%
Interchannel Gain Mismatch (Difference of Gain Errors)			±0.5	dB
Total Audible Out-of-Band Energy ¹ (Measured from $0.6 \times f_s$ to 20 kHz)		-85		dB
DAC Crosstalk ¹ (Input L, Zero R, Measure R_OUT; Input R, Zero L, Measure L_OUT)		-95		dB
DAC VOLUMES				
Step Size (DAC-0, DAC-1)		1.5		dB
Output Gain/Attenuation Range	-58.5		0	dB
Mute Attenuation of 0 dB Fundamental ¹		-80		dB
ADC VOLUMES				
Step Size (ADCSEL-0, ADCSEL-1)		1.5		dB
PGA Gain/Attenuation Range	-58.5		+22.5	dB
ANALOG MIXER				
Signal-to-Noise Ratio Input to Output – Ports B, C, or F, to Port D Output		90		dB
Step Size: All Mixer Inputs		-1.5		dB
Input Gain/Attenuation Range: All Mixer Inputs	-34.5		+12.0	dB
ANALOG LINE LEVEL OUTPUTS				
Full-Scale Output Voltage: Line Out Drive Enabled	1.0			V rms ³
Ports A, D, E, F, and Mono Out	2.83			V p-p
Output Impedance ¹		190		Ω
External Load Impedance ¹	10			kΩ
Output Capacitance ¹		15		pF
External Load Capacitance			1000	pF
ANALOG HP DRIVE OUTPUTS				
Full-Scale Output Voltage: Line Out Drive Enabled	1.0			V rms
Ports A and D (when HP Drive is Enabled)	2.83			V p-p
Output Impedance ¹			0.5	Ω
External Load Impedance ¹	32			Ω
Output Capacitance ¹		15		pF
External Load Capacitance ¹			1000	pF
ANALOG INPUTS				
Input Voltages—Port B, C, or E		1		V rms
Mic Boost = 0 dB		2.83		V p-p
Input Voltages—Microphone Boost Amplifier, Ports B, C, or E		0.316		V rms
Mic Boost = +10 dB		0.894		V p-p
Mic Boost = +20 dB		0.1		V rms
Mic Boost = +30 dB		0.283		V p-p
		0.032		V rms
		0.089		V p-p
Input Impedance				
PCBEEP		23		kΩ
Ports B, C, E (Mic Boost = 0 dB)		150		kΩ
Port F		45		kΩ
Input Capacitance ¹		5	7.5	pF

AD1884

Parameter	Min	Typ	Max	Unit
MICROPHONE BIAS				
MIC_BIAS-B, MIC_BIAS-C				
MIC_BIAS_IN (Pin 33) = +5 V or +3.3 V	V_{REF} Setting = Hi-Z	Hi-Z		V dc
	V_{REF} Setting = 0 V	0		V dc
	V_{REF} Setting = 50%	1.65		V dc
MIC_BIAS_IN (Pin 33) = +5 V	V_{REF} Setting = 80%	3.7		V dc
	V_{REF} Setting = 100%	3.9		V dc
MIC_BIAS_IN (Pin 33) = +3.3 V	V_{REF} Setting = 80%	2.86		V dc
	V_{REF} Setting = 100%	3.0		V dc
MIC_BIAS-E (When enabled as BIAS)	V_{REF} Setting = Hi-Z	Hi-Z		V dc
	V_{REF} Setting = 0 V	0		V dc
	V_{REF} Setting = 50%	1.65		V dc
	V_{REF} Setting = 80%	2.86		V dc
	V_{REF} Setting = 100%	3.0		V dc
Output Drive Current	V_{REF} Setting = 50%, 80%, or 100%	1.6		mA
GPIO 0				
Input Signal High (V_{IH})		$DV_{IO} \times 0.60$	DV_{IO}	V
Input Signal Low (V_{IL})		0	$DV_{IO} \times 0.24$	V
Output Signal High (V_{OH})	$I_{OUT} = -500 \mu A$	$DV_{IO} \times 0.72$	DV_{IO}	V
Output Signal Low (V_{OL})	$I_{OUT} = +1500 \mu A$	0	$DV_{IO} \times 0.10$	V
Input Leakage Current (Signal High) (I_{IH})		-150		nA
Input Leakage Current (Signal Low) (I_{IL})		-50		μA
GPIO 1 and 2				
Input Signal High (V_{IH})		$AV_{DD} \times 0.60$	AV_{DD}	V
Input Signal Low (V_{IL})		0	$AV_{DD} \times 0.24$	V
Output Signal High (V_{OH})	$I_{OUT} = -500 \mu A$	$AV_{DD} \times 0.72$	AV_{DD}	V
Output Signal Low (V_{OL})	$I_{OUT} = +1500 \mu A$	0	$AV_{DD} \times 0.10$	V
Input Leakage Current (Signal High) (I_{IH})		-150		nA
Input Leakage Current (Signal Low) (I_{IL})		-50		μA
POWER SUPPLY				
Analog (AV_{DD}) 3.3 V $\pm 5\%$				
Power Supply Range	3.13	3.30	3.46	V
Power Dissipation		99		mW
Supply Current		31		mA
Digital (DV_{DD}) 3.3 V $\pm 10\%$				
Power Supply Range	2.97	3.30	3.63	V
Power Dissipation		162		mW
Supply Current		58		mA
Digital I/O (DV_{IO}) 3.3 V $\pm 10\%$				
Power Supply Range	2.97	3.30	3.63	V
Power Dissipation		3.96		mW
Supply Current		1.2		mA
Power Supply Rejection (reference to f_s 100 mV p-p Signal @ 1 kHz) ¹		80		dB

¹ Guaranteed but not tested.

² Measurements reflect main ADC.

³ RMS values assume sine wave input.

HD-AUDIO LINK SPECIFICATION

High-definition audio signals comply with the High-definition Audio specification. Please refer to these specifications at:

<http://www.intel.com/standards/hdaudio/>

POWER DOWN STATES

Parameter	ID _{VDD} Typ	IA _{VDD} Typ	Unit
Function Node in D0, All Nodes Active	58	31	mA
Function Node in D3 ¹	21	2	mA
Codec in RESET	3	3	mA
Individual Block Power Savings			
DAC Pair Powered Down Saves (Each)	6	5	mA
ADC Pair Powered Down Saves (Each)	5	3	mA
Mixer Power Control (And Associated Amps) Saves	0	2	mA
MIC_BIAS Powered Down Saves ²	0	0.5	mA

¹ Function node D3 state powers down all nodes except for the V_{REF}, Mixer and MIC_BIAS nodes which have independent power controls. V_{REF} should be kept active when background functions such as jack presence detection or analog pass-through are required. Mixer should be kept active when analog pass-through is required. MIC_BIAS can be disabled if microphones are not in use in the power-down state.

² Powering down the MIC_BIAS powers down all port MIC_BIAS pins. This disables all microphone bias circuits set to 100% or 50%, setting them to the Hi-Z state. The 0 Ω and Hi-Z states remain unaffected by the MIC_BIAS power state.

ABSOLUTE MAXIMUM RATINGS

Stresses greater than those listed below may cause permanent damage to the device. This is a stress rating only; functional operation of the device at these or any other conditions above those indicated in the operational section of this specification is not implied. Exposure to absolute maximum rating conditions for extended periods may affect device reliability.

Power Supplies	Min	Max	Units
Digital (DV _{DD})	-0.30	+3.65	V
Digital I/O (DV _{IO})	-0.30	+3.65	V
Analog (AV _{DD})	-0.30	+3.65	V
Input Current (Except Supply Pins)		±10.0	mA
Analog Input Voltage (Signal Pins)	-0.30	AV _{DD} + 0.3	V
Digital Input Voltage (Signal Pins)	-0.30	DV _{IO} + 0.3	V
Ambient Temperature (Operating)	0	+70	°C
Storage Temperature	-65	+150	°C

ESD SENSITIVITY



ESD (electrostatic discharge) sensitive device.
 Charged devices and circuit boards can discharge without detection. Although this product features patented or proprietary circuitry, damage may occur on devices subjected to high energy ESD. Therefore, proper ESD precautions should be taken to avoid performance degradation or loss of functionality.

ENVIRONMENTAL CONDITIONS

Ambient Temperature Rating

$$T_{AMB} = T_{CASE} - (PD \times \theta_{CA})$$

T_{CASE} = Case Temperature in °C

PD = Power Dissipation in W

θ_{CA} = Thermal Resistance (Case-to-Ambient)

θ_{JA} = Thermal Resistance (Junction-to-Ambient)

θ_{JC} = Thermal Resistance (Junction-to-Case)

All measurements per EIA-JESD51 with 2S2P test board per EIA-JESD51-7.

Table 2. Thermal Resistance

Package	θ _{JA}	θ _{JC}	θ _{CA}	Unit
LFCSP_VQ	47	15	32	°C/W

PIN CONFIGURATION AND FUNCTION DESCRIPTIONS

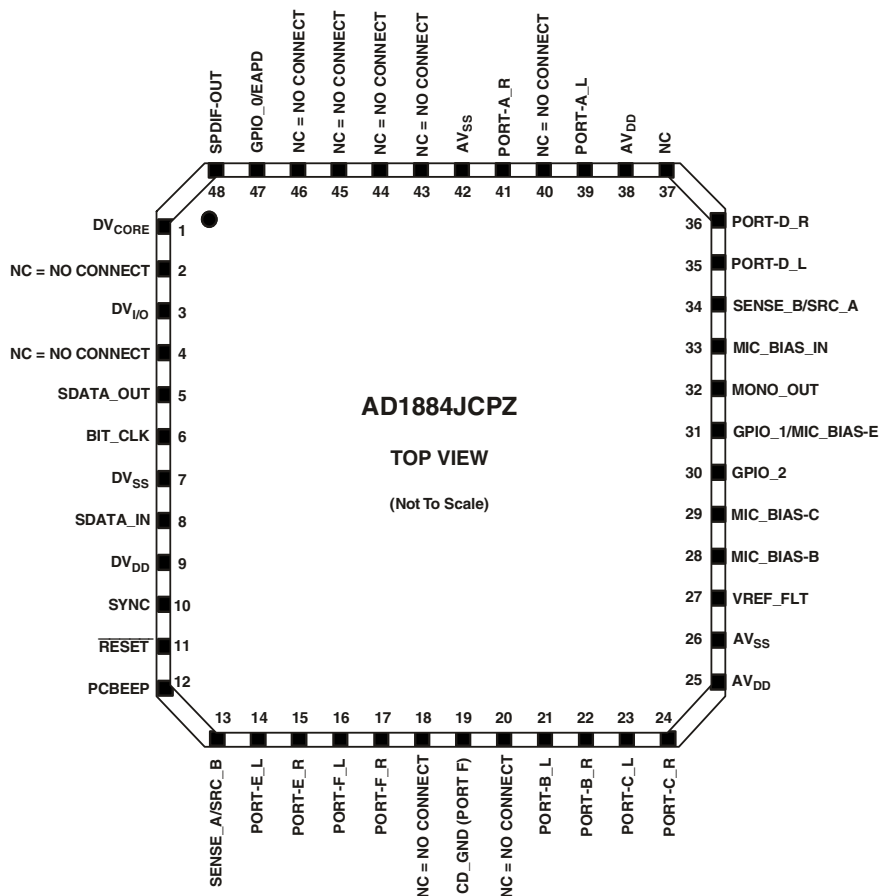

Figure 2. AD1884 48-Lead Package and Pinout

AD1884

Table 3. AD1884 Pin Descriptions

Mnemonic	Pin No.	I/O	Description
DIGITAL INTERFACE			
SDATA_OUT	5	I	Link Serial Data Output. AD1884 input stream. Clocked on both edges of the BIT_CLK.
BIT_CLK	6	I	Link Bit Clock. 24.000 MHz serial data clock.
SDATA_IN	8	I/O	Link Serial Data Input. AD1884 output stream clocked only on one edge of BIT_CLK.
SYNC	10	I	Link Frame Sync.
RESET	11	I	Link Reset. AD1884 master hardware reset.
DIGITAL I/O			
GPIO_2	30	I/O	General Purpose I/O/Microphone Bias for Port E. Capable of Hi-Z, 1.65 V, and 2.86 V. Pin 31 shares functionality between GPIO_1 and MIC_BIAS_E. These functions are mutually exclusive.
GPIO_1/MIC_BIAS-E	31	I/O	
GPIO_0/EAPD	47	I/O	EAPD/General Purpose Input/Output pin. Pin 47 shares functionality between GPIO_0 and EAPD. These functions are mutually exclusive and the EAPD function takes priority over the GPIO function. By default, the pin is in a Hi-Z state. External resistors should be used to insure the proper circuit state when this pin is in Hi-Z.
S/PDIF_OUT	48	O	S/PDIF_OUT – Supports S/PDIF output.
JACK SENSE AND EAPD			
SENSE_A/SRC_B	13	I/O	Jack Sense A-D Input/Sense B drive.
SENSE_B/SRC_A	34	I/O	Jack Sense E-F Input/Sense A drive.
ANALOG I/O			
PCBEEP	12	LI	Monaural Input from system for Analog PCBEEP.
Port E_L	14	LI, MIC, LO	Auxiliary Input/Output Left Channel.
Port E_R	15	LI, MIC, LO	Auxiliary Input/Output Right Channel.
Port F_L	16	LI, LO	Auxiliary Input/Output Left Channel.
Port F_R	17	LI, LO	Auxiliary Input/Output Right Channel.
CD_GND	19	I	CD-Audio-Analog-Ground-Reference. Must be connected to AGND via a 0.1 μ F capacitor if not in use as CD_GND. MUST always be ac-coupled.
Port B_L	21	LI, MIC	Front Panel stereo MIC/Line-In.
Port B_R	22	LI, MIC	Front Panel stereo MIC/Line-In.
Port C_L	23	LI, MIC	Rear Panel stereo MIC/Line-In.
Port C_R	24	LI, MIC	Rear Panel stereo MIC/Line-In.
MONO_OUT	32	LO	Monaural Output to Internal Speaker or Telephony Subsystem Speakerphone.
Port D_L	35	HP, LO	Rear Panel Headphone/Line-Out.
Port D_R	36	HP, LO	Rear Panel Headphone/Line-Out.
Port A_L	39	HP, LO	Front Panel Headphone/Line-Out.
Port A_R	41	HP, LO	Front Panel Headphone/Line-Out.
FILTER/REFERENCE			
V _{REF_FILT}	27	O	Voltage Reference Filter.
MIC_BIAS-B	28	O	Switchable Microphone Bias. For use with Port B (Pins 21, 22).
MIC_BIAS-C	29	O	Switchable Microphone Bias. For use with Port C (Pins 23, 24). Both MIC bias pins are capable of Hi-Z, 0 V, 1.65 V, 3.7 V, and 3.9 V (with 5.0 V on Pin 33), Hi-Z, 0 V, 1.65 V, 2.86 V, and 3.0 V (with 3.3 V on Pin 33).
DV _{CORE}	1	O	CAUTION: DO NOT APPLY 3.3 V TO THIS PIN! Filter connection for internal core voltage regulator. This pin must be connected to filter caps: 10 μ f, 1.0 μ f, and 0.1 μ f connected in parallel between Pin 1 and D _{VSS} (Pin 7).
POWER AND GROUND			
DV _{IO} 3.3V	3	I	Link Digital I/O Voltage Reference. 3.3 V
DV _{SS}	7	I	Digital Supply Return (ground).
DV _{DD} 3.3 V	9	I	Digital Supply Voltage 3.3 V. This is regulated down to DV _{CORE} on Pin 1 to supply the internal digital core internal to the AD1884.

The symbols used in this table are defined as: I = Input, O = Output, LI = Line Level Input, LO = Line Level Output, HP = Output capable of driving headphone load, MIC = Input supports microphones with MIC bias and boost amplifier.

Table 3. AD1884 Pin Descriptions (Continued)

Mnemonic	Pin No.	I/O	Description
AV _{DD} 3.3 V	25, 38	I	CAUTION: DO NOT APPLY 5 V TO THESE PINS! Analog Supply Voltage 3.3 V ONLY. Note: AV _{DD} supplies should be well regulated and filtered as supply noise degrades audio performance.
MIC_BIAS_IN 5.0 V or 3.3 V	33	I	Source Power for Microphone Bias Boost Circuitry. Connect this pin to 5.0 V via a low-pass filter. When connected this way the AD1884 is capable of providing +3.9 V as a mic bias to all of the mic bias pins (except on Pin 31). If 5 V is not available, connect this pin to +3.3 V (AV _{DD}) via a low-pass filter. The AD1884 produces a mic bias voltage relative to the AV _{DD} supply (typically 3.0 V @ AV _{DD} = 3.3 V).
AV _{SS}	26, 42	I	Analog Supply Return (Ground). AV _{SS} should be connected to DV _{SS} using a conductive trace under, or close to, the AD1884.

The symbols used in this table are defined as: I = Input, O = Output, LI = Line Level Input, LO = Line Level Output, HP = Output capable of driving headphone load, MIC = Input supports microphones with MIC bias and boost amplifier.

HD AUDIO WIDGETS

Table 4. HD Audio Widgets

Node ID	Name	Type ID	Type	Description
00	ROOT	x	Root	Device identification
01	FUNCTION	x	Function	Designates this device as an audio codec
02	S/PDIF DAC	0	Audio Output	S/PDIF digital stream output interface
03	DAC_0	0	Audio Output	Stereo headphone channel digital/audio converters
04	DAC_1	0	Audio Output	Stereo front channel digital/audio converters
05	VendorD_1	F	Vendor Defined	Vendor Defined
06	VendorD_2	F	Vendor Defined	Vendor Defined
07	Port A Mixer	2	Audio Mixer	Mixes the of DAC_(0, 1) and mixer output amps to drive Port A
08	ADC_0	1	Audio Input	Stereo record Channel 0 audio/digital converters
09	ADC_1	1	Audio Input	Stereo record Channel 1 audio/digital converters
0A	Port D Mixer	2	Audio Mixer	Mixes the DAC_1 and mixer output amps to drive Port D
0B	Port F Mixer	2	Audio Mixer	Mixes the DAC_(0, 1) and mixer output amps to drive Port F
0C	ADC Selector 0	3	Audio Selector	Selects and amplifies/attenuates the input to ADC_0
0D	ADC Selector 1	3	Audio Selector	Selects and amplifies/attenuates the input to ADC_1
0E	Mono Out Selector	3	Audio Selector	Selects the mono out DAC_(0, 1)
0F	Port F Out Selector	3	Audio Selector	Selects the Port F DAC_(0, 1)
10	Digital Beep	7	Beep Generator	Internal digital PCBeep signal
11	Port A (Headphone)	4	Pin Complex	Headphone jack pins
12	Port D (Line Out)	4	Pin Complex	Line out jack pins
13	Mono Out	4	Pin Complex	Monaural output pin (internal speakers or telephony system)
14	Port B (Mic In)	4	Pin Complex	Microphone in jack pins
15	Port C (Line In)	4	Pin Complex	Line in jack pins
16	Port F (Aux In/Out)	4	Pin Complex	Auxiliary I/O pins
17	VendorD_3	F	Vendor Defined	Vendor Defined
18	VendorD_4	F	Vendor Defined	Vendor Defined
19	Mixer Power Down	5	Power Widget	Powers down the analog mixer and associated amps
1A	Analog PCBeep	4	Pin Complex	External analog PCBeep signal input
1B	S/PDIF Out Pin	4	Pin Complex	S/PDIF output pin
1C	Port E (Dock I/O)	4	Pin Complex	Analog dock I/O pins
1D	V _{REF} Power Down	F	Vendor Defined	Powers down the internal and external V _{REF} circuitry
1E	Mono Out Mixer	2	Audio Mixer	Mixes the DAC_(0, 1) and mixer output amps to drive mono out
1F	Stereo Mix-Down	2	Audio Mixer	Mixes the stereo L/R channels to drive mono output
20	Analog Mixer	2	Audio Mixer	Mixes individually gainable analog inputs
21	Mixer Output Atten	3	Audio Selector	Attenuates the mixer output to drive the port mixers
22	Port A Out Selector	3	Audio Selector	Selects the Port A DAC_(0, 1)
23	Port E Out Selector	3	Audio Selector	Selects the Port E DAC_(0, 1)
24	Port E Mixer	2	Audio Mixer	Mixes the DAC_(0, 1) and mixer output amps to drive Port E
25	Port E Mic Boost	3	Audio Selector	0 dB, 10 dB, 20 dB, or 30 dB gain boost for Port E
26	BIAS Power Down	F	Vendor Defined	Powers down the internal MIC_BIAS_FILT and all MIC_BIAS pins

AD1884 HD AUDIO PARAMETERS

Table 5. Root and Function Node Parameters

Node ID	Name	Type	Vendor ID 00	Revision ID 02	Sub Node Count 04	Func. Group Type 05	Audio F.G. Caps 08	GPIO Caps 11
00	ROOT	Root	11D41884	00100100	00010001			
01	FUNCTION	Function			00020025	00000001	00010C0C	40000003

Table 6. SubSystem ID ¹

Node ID	Name	31:16 SSID	15:8 SKU	7:0 Asm ID
01	FUNCTION	BFD4	00	00

¹The SSID value is set on codec power-up only. SSID is not reset by link or soft reset in order to preserve modifications by BIOS control.

Table 7. Widget Parameters

Node ID	Widget Capabilities 09	PCM Size, Rate 0A	Stream Formats 0B	Pin Capabilities 0C	Input Amp Capabilities 0D	Con. List Length 0E	Power States 0F	Output Amp Capabilities 12
01	000004C0	000E07FF	00000001		80000000		00000009	00052727
02	00030311	000E07E0	00000005			00000003		
03	00000405	000E07FF	00000001			00000000	00000009	00052727
04	00000405	000E07FF	00000001			00000000	00000009	00052727
07	00200103				80000000	00000002		
08	00100501	000E07FF	00000001			00000001	00000009	
09	00100501	000E07FF	00000001			00000001	00000009	
0A	00200103				80000000	00000002		
0B	00200103				80000000	00000002		
0C	0030010D					00000004		80053627
0D	0030010D					00000004		80053627
0E	00300101					00000002		
0F	00300101					00000002		
10	0070000C					00000000		800B0F0F
11	0040018D			0000001F		00000001		80000000
12	0040058D			0001001F		00000001	00000009	80000000
13	0040050C			00010010		00000001	00000009	80051F1F
14	0040008B			00003727	00270300	00000000		
15	0040008B			00003727	00270300	00000000		
16	0040018D			00000037		00000001		80000000
19	00500500					00000002	00000009	
1A	00400000			00000020		00000000		
1B	0040030D			00000010		00000001		80052727
1C	0040018D			00003737		00000001		80000000
1D	00F00100					0000000A		
1E	00200103				80000000	00000002		
1F	00200100					00000001		
20	0020010B				80051F17	00000004		
21	0030010D					00000001		80051F1F
22	00300101					00000002		
23	00300101					00000002		
24	00200103				80000000	00000002		
25	0030010D					00000001		00270300
26	00F00100					00000003		

AD1884

Table 8. Connection List

Node ID	Connection			0	1	2	3	4	5	6	7	8	9
	[0-3]	[4-7]	[8-11]	I NID	I NID	I NID	I NID	I NID	I NID	I NID	I NID	I NID	I NID
02	00090801			01	08	09							
03													
04													
07	00002122			03	21								
08	0000000C			0C									
09	0000000D			0D									
0A	00002104			04	21								
0B	0000210F			0F	21								
0C	25209614			14	16	20	25						
0D	25209614			14	16	20	25						
0E	00000403			03	04								
0F	00000403			03	04								
10													
11	00000007			07									
12	0000000A			0A									
13	0000001F			1F									
14													
15													
16	0000000B			0B									
19	00002120			20	21								
1A													
1B	00000002			02									
1C	00000024			24									
1D	8F0A1907	96111C1A	0000A61E	07	19	0A	1 0F	1A	1C	11	1 16	1E	1 26
1E	0000210E			0E	21								
1F	0000001E			1E									
20	251A9614			14	16	1A	25						
21	00000020			20									
22	00000403			03	04								
23	00000403			03	04								
24	00002123			23	21								
25	0000001C			26									
26	001C1514			14	15								

In Table 9, default configuration values are set on codec power-up only. Default configuration values are not reset by link or soft reset to preserve modifications by BIOS control.

Table 9. Default Configuration Bytes

ID	Name	Value	31:30	29:28	27:24	23:20	19:16	15:12	8	7:4	3:0
			Connectivity	Location		Def. Device	Conn Type	Color	JD OR	Def Assn.	Seq.
				Chasis	Position						
11	Port A	0321401F	Jack	External	Left	HP Out	1/8" Jack	Green	0	1	F
12	Port D	90130110	Fixed	Internal	N/A	Speaker	ATAPI	Unknown	1	1	0
13	Mono Out	901301F0	Fixed	Internal	N/A	Speaker	ATAPI	Unknown	1	F	0
14	Port B	03A190F0	Jack	External	Left	Mic In	1/8" Jack	Pink	0	F	0
15	Port C	96A30120	Fixed	Internal	Bottom	Mic In	ATAPI	Unknown	1	2	0
16	Port F	99330121	Fixed	Internal	Special 3	CD	ATAPI	Unknown	1	2	1
1A	Analog PCBeep	90F301F0	Fixed	Internal	N/A	other	ATAPI	Unknown	1	F	0
1B	S/PDIF Out Pin	014511F0	Jack	External	Rear	SPDIF Out	Optical	Black	1	F	0
1C	Port E	21A1902E	Jack	Separate	Rear	Mic In	1/8" Jack	Pink	0	2	E

OUTLINE DIMENSIONS

Dimensions are shown in millimeters.

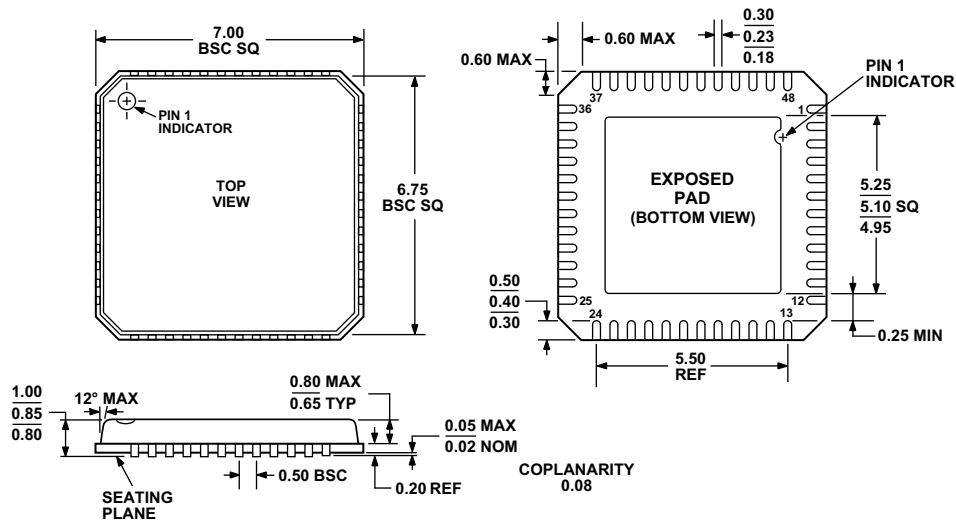

COMPLIANT TO JEDEC STANDARDS MO-220-VKGD-2

Figure 3. 48-Lead, Pb-Free, Frame Chip Scale Package [LFCSP_VQ]
7 mm x 7 mm Body, Very Thin Quad (CP-48-1)

ORDERING GUIDE

Model	Temperature Range	Package Description	Package Option
AD1884JCPZ ¹	0°C to 70°C	48-Lead LFCSP_VQ	CP-48-1
AD1884JCPZ-RL ¹	0°C to 70°C	48-Lead LFCSP_VQ	CP-48-1

¹Z = Pb-free part.

AD1884