

# Fast Asymmetric Thyristors

Type	$V_{DRM}$ V $V_{DSM} = V_{DRM}$	$V_{RRM}$ V $V_{RRM(C)}$ $t_q = 1 \mu s$	$I_{TRSM}$ A	$I_{TSM}$ kA 10ms $t_{vj \max}$	$\int i^2 dt$ A <sup>2</sup> s 10ms $t_{vj \max}$ $\cdot 10^3$	$I_{TAVM}/t_C$ A/°C 180° el sin	$V_{(TO)}$ V $t_{vj} = t_{vj \max}$	$r_T$ mΩ $t_{vj} = t_{vj \max}$	$(di/dt)_{cr}$ A/μs DIN IEC 747-6	$tq^1$ μs	$(dv/dt)_{cr}$ V/μs DIN IEC 747-6	$V_{GT}$ V $t_{vj} = 25^\circ C$	$I_{GT}$ mA $t_{vj} = 25^\circ C$	$R_{thJC}$ °C/W 180° el sin	$t_{vj \max}$ °C	outline
A 158 S	600...1300*	15 (50)	400	2,5	30	158/85	1,30	2,0	400	D ≤ 15 C ≤ 12 B ≤ 10 A ≤ 8 <sup>2)</sup>	C = 500 F = 1000	2,7	300	0,117	125	116
A 198 S	600...1300*	15 (50)	400	2,7	36,5	198/85	1,10	1,3	400	E ≤ 20 D ≤ 15	C = 500 F = 1000	2,7	300	0,117	125	116
A 358 S	600...1300*	15 (50)	800	5,0	125	358/85	1,30	0,9	500	D ≤ 15 C ≤ 12 B ≤ 10 A ≤ 8 <sup>2)</sup>	C = 500 F = 1000	2,7	300	0,053	125	117
A 438 S	600...1300*	15 (50)	900	5,5	151	438/85	1,10	0,6	500	F ≤ 25 E ≤ 20 D ≤ 15	C = 500 F = 1000	2,7	300	0,053	125	117
■ A 901 S	2500, 2800	20 (25)	2200	16,0	1280	900/85	1,45	0,3	250	P ≤ 55	F = 1000	2,5	300	0,021	125	118
■ A 931 S	1800, 2000	20 (25)	2200	16,0	1280	930/85	1,35	0,3	300	G ≤ 30 F ≤ 25	F = 1000	2,5	300	0,021	125	118

■ Not for new design

<sup>1)</sup> With fast inverse diode

\* Delivery for large quantities on request

<sup>2)</sup>  $V_{DRM} \leq 1000$  V

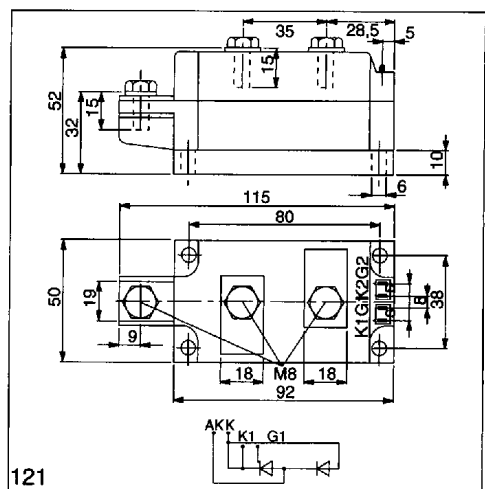
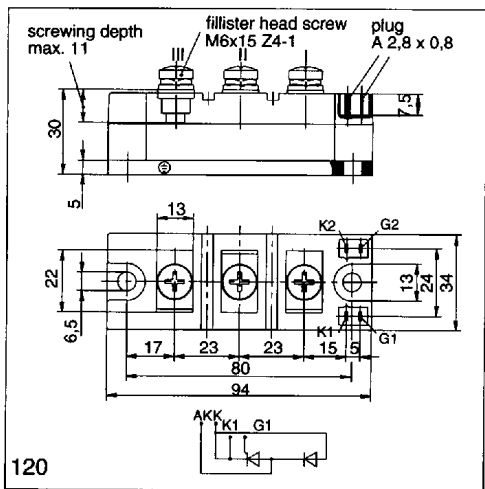
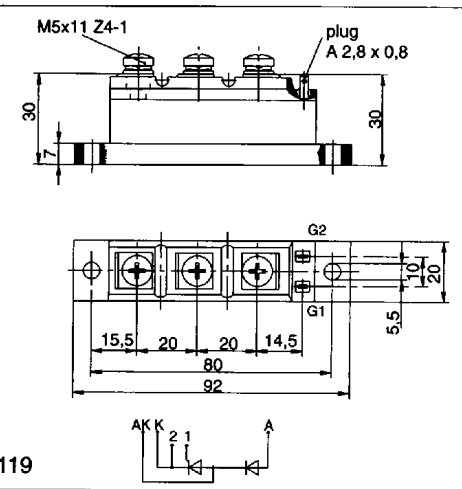
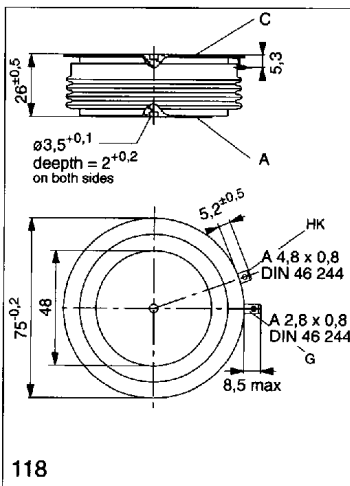
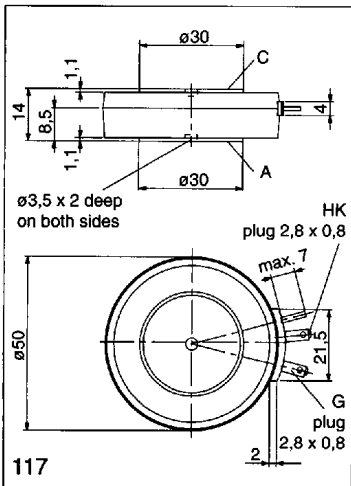
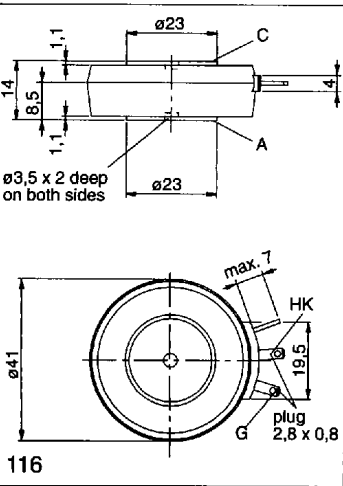

# Fast Asymmetric Thyristor Modules

Type	$V_{DRM}$ V $V_{DSM} = V_{DRM}$	$V_{RRM}$ V ( $V_{RRM(C)}$ ) $t_p = 1 \mu s$	$I_{TRMSM}$ A	$I_{TSM}$ A 10 ms, $t_{vjmax}$	$\int i^2 dt$ A <sup>2</sup> s 10 ms, $t_{vjmax} * 10^3$	$I_{TAVM}/t_c$ A/°C 180° el sin	$V_{(TO)}$ V $t_{vj} = t_{vjmax}$	$r_T$ mΩ $t_{vj} = t_{vjmax}$	$(di/dt)_{cr}$ A/μs DIN IEC 747-6	$t_q$ <sup>1)</sup> μs	$(di/dt)_{cr}$ V/μs DIN IEC 747-6	$R_{thJC}$ °C/W 180° el sin	$R_{thCK}$ °C/W	$t_{vjmax}$ °C	outline
<b>Baseplate = 20 mm</b>															
AD 50 F	800...1300*	15 [50]	120	1300	8,45	50/85 76/56	1,3	3,75	120	$E \leq 20$ $D \leq 15$ $C \leq 12$ $B \leq 10$ $A \leq 8^{2)}$	$C = 500$ $F = 1000$	0,45	0,16	125	119
AD 60 F	800...1300*	15 [50]	150	1450	10,5	60/85 95/56	1,2	2,80	120	$E \leq 20$ $D \leq 15$ $C \leq 12$ $B \leq 10$ $A \leq 8^{2)}$	$C = 500$ $F = 1000$	0,39	0,16	125	119
<b>Baseplate = 34 mm</b>															
AD 96 S	800...1300*	15 [50]	200	2350	27,6	95/85 127/67	1,3	2,15	400	$D \leq 15$ $C \leq 12$ $B \leq 10$ $A \leq 8^{2)}$	$C = 500$ $F = 1000$	0,23	0,06	125	120
AD 116 S	800...1300*	15 [50]	220	2600	33,8	115/85 140/74	1,1	1,45	400	$E \leq 20$ $D \leq 15$	$C = 500$ $F = 1000$	0,23	0,06	125	120
<b>Baseplate = 50 mm</b>															
AD 180 S	800...1300*	15 [50]	350	4800	115	180/85 223/73	1,3	0,90	500	$D \leq 15$ $C \leq 12$ $B \leq 10$ $A \leq 8^{2)}$	$C = 500$ $F = 1000$	0,13	0,04	125	121
AD 220 S	800...1300*	15 [50]	410	5200	135	220/85 261/75	1,1	0,60	500	$F \leq 25$ $E \leq 20$ $D \leq 15$	$C = 500$ $F = 1000$	0,13	0,04	125	121

Most types of the power modules have been UL-recognized

\*Delivery for large quantities on request

<sup>1)</sup> With fast inverse diode

<sup>2)</sup>  $V_{DRM} \leq 1000$  V

## Insulated cells

Type	$V_M$ V	$V_{RMS}$ V	CTI-value	Iso-class	$t_c$ (max) °C	$R_{thCK}$ °C/W	$R_{thC-C}$ (typ) °C/W	clamping force kN	$F_{max}$ kN	weight g	outline
ISO 57/26	6400	2520	250	III a	150	0,010	0,099	20	30	260	122
ISO 75/26	5900	2250	250	III a	150	0,005	0,052	40	45	460	123
ISO 65/35	10600	4180	250	III a	150	0,010	0,146	20	30	350	124
ISO 120/35	11700	4400	250	III a	150	0,002	0,030	45	70	1650	125
ISO 120/59		on request									

Mech. values refer to the material of the case

Insulating material: AlN

# ISOPACK Modules

Type	$V_{DRM}, V_{RRM}$ V $V_{DSM} = V_{DRM}$ $V_{RSM} = V_{RRM} + 100$ V	$I_{FRMSM}$ A 10 ms, $t_{vj\ max}$	$I_{FSM}$ A	$\int i^2 dt$ A <sup>2</sup> s 10 ms, $t_{vj\ max}$	$I_d/t_C$ A/°C	$V_{(TO)}$ V $t_{vj} = t_{vj\ max}$	$r_T$ mΩ $t_{vj} = t_{vj\ max}$	$R_{thJC}$ °C/W per arm	$R_{thCK}$ °C/W per arm	$t_{vj\ max}$ °C	outline
<b>Single phase diode bridges</b>											
DD B2U 15 N	800...1600	12	480	1150	15/95	0,75	7,5	7,8 <sup>1)</sup>	0,6	150	126
<b>Three phase diode bridges</b>											
DD B6U 20 N	800...1600	15	480	1150	20/87	0,75	7,5	10 <sup>2)</sup>	0,9	150	127
■ DD B6U 60 N	1000...1600	50	500	1250	60/110	0,80	6,8	1,7 <sup>2)</sup>	0,2	150	129
▼ DD B6U 85 N	1000...1600	60	550	1510	85/100	0,75	5,5	1,45 <sup>2)</sup>	0,2	150	129A
■ DD B6U 70 N	1000...1600	60	550	1500	70/110	0,75	5,8	1,5 <sup>2)</sup>	0,2	150	129
■ DD B6U 90 N	1000...1600	75	850	3600	90/110	0,80	4,1	1,15 <sup>2)</sup>	0,2	150	129
■ DD B6U 110 N	1000...1600	90	950	4500	110/110	0,75	3,4	0,95 <sup>2)</sup>	0,2	150	129
■ DD B6U 130 N	1000...1600	100	1150	6600	130/110	0,80	2,7	0,8 <sup>2)</sup>	0,2	150	129
▼ DD B6U 145 N	1000...1600	100	1000	5000	145/100	0,75	3,1	0,89 <sup>2)</sup>	0,2	150	129A
■ DD B6U 160 N	1000...1600	120	1350	9100	160/110	0,75	2,2	0,68 <sup>2)</sup>	0,2	150	129
▼ DD B6U 205 N	1000...1600	120	1375	9450	205/100	0,75	2,2	0,59 <sup>2)</sup>	0,2	150	129A
<b>Three phase bridges, fully controlled</b>											
■ TT B6C 60 N	600...1600	50	500	1250	60/85	1,05	8,0	1,3 <sup>1)</sup>	0,2	125	128
■ TT B6C 75 N	600...1600	60	580	1680	75/85	1,00	6,0	1,1 <sup>1)</sup>	0,2	125	128
■ TT B6C 90 N	600...1600	75	750	2810	90/85	1,05	5,2	0,86 <sup>1)</sup>	0,2	125	128
▼ TT B6C 95 N	1000...1200	75	620	1920	95/85	0,95	5,5	0,82 <sup>2)</sup>	0,2	125	129B
■ TT B6C 110 N	600...1600	90	870	3780	110/85	1,00	4,2	0,75 <sup>1)</sup>	0,2	125	128
▼ TT B6C 135 N	1000...1200	100	900	4050	135/85	0,95	4,3	0,59 <sup>2)</sup>	0,2	125	129B
▼ TT B6C 165 N	1000...1200	120	1200	7200	165/85	0,95	3,2	0,49 <sup>2)</sup>	0,2	125	129B
<b>Three phase bridges, half controlled</b>											
■ TD B6HK 60 N	600...1600	50	500	1250	60/85	1,05	8,0	1,3 <sup>1)</sup>	0,2	125	128
■ TD B6HK 75 N	600...1600	60	580	1680	75/85	1,00	6,0	1,1 <sup>1)</sup>	0,2	125	128
■ TD B6HK 90 N	600...1600	75	750	2810	90/85	1,05	5,2	0,86 <sup>1)</sup>	0,2	125	128
▼ TD B6HK 95 N	1000...1200	75	620	1920	95/85	0,95	5,5	0,82 <sup>2)</sup>	0,2	125	129B
■ TD B6HK 110 N	600...1600	90	870	3780	110/85	1,00	4,2	0,75 <sup>2)</sup>	0,2	125	128
▼ TD B6HK 135 N	1000...1200	100	900	4050	135/85	0,95	4,3	0,59 <sup>2)</sup>	0,2	125	129B
▼ TD B6HK 165 N	1000...1200	120	1200	7200	165/85	0,95	3,2	0,49 <sup>2)</sup>	0,2	125	129B
<b>Single phase bridges, fully controlled</b>											
■ TT B2C 70 N	600...1600	75	750	2810	70/85	1,05	5,2	0,75 <sup>2)</sup>	0,2	125	128
■ TT B2C 85 N	600...1600	90	870	3780	85/85	1,00	4,2	0,65 <sup>2)</sup>	0,2	125	128
<b>Single phase bridges, half controlled</b>											
■ TD B2HZ 70 N	600...1600	75	750	2810	70/85	1,05	5,2	0,75 <sup>2)</sup>	0,2	125	128
■ TD B2HZ 85 N	600...1600	90	870	3780	85/85	1,00	4,2	0,65 <sup>2)</sup>	0,2	125	128
<b>Single phase bridges, half controlled, with free-wheeling diode</b>											
■ TD B2HKF 70 N	600...1600	75	750	2810	70/85	1,05	5,2	0,75 <sup>2)</sup>	0,2	125	128
■ TD B2HKF 85 N	600...1600	90	870	3780	85/85	1,00	4,2	0,65 <sup>2)</sup>	0,2	125	128
<b>Three phase AC switches</b>											
■ TT W3C 80 N	600...1600	75	750	2810	(80/85)	1,05	5,2	0,75 <sup>2)</sup>	0,2	125	128
▼ TT W3C 85 N	1000...1600	75	620	1920	85/85	0,95	5,5	0,7 <sup>1)</sup>	0,2	125	129B
■ TT W3C 95 N	600...1600	90	870	3780	(95/85)	1,00	4,2	0,65 <sup>2)</sup>	0,2	125	128
▼ TT W3C 115 N	1000...1600	100	900	4050	115/85	0,95	4,3	0,5 <sup>1)</sup>	0,2	125	129B
▼ TT W3C 145 N	1000...1600	120	1200	7200	145/85	0,95	3,2	0,42 <sup>1)</sup>	0,2	125	129B

Most types of the power modules have been UL-recognized

<sup>1)</sup> 180° el Sinus

<sup>2)</sup> 120° el Square

■ not for new design

▼ New type

