

Agilent ACSL-6xx0 Multi-Channel and Bi-Directional, 15 MBd Digital Logic Gate Optocoupler Data Sheet

Description

ACSL-6xx0 are truly isolated, multi-channel and bi-directional, high-speed optocouplers. Integration of multiple optocouplers in monolithic form is achieved through patented process technology. These devices provide full duplex and bi-directional isolated data transfer and communication capability in compact surface mount packages. Available in 15 Mbd speed option and wide supply voltage range.

These high channel density make them ideally suited to isolating data conversion devices, parallel buses and peripheral interfaces.

They are available in 8-pin and 16-pin narrow-body SOIC package and are specified over the temperature range of -40°C to +100°C.

Applications

- Full duplex communication
- Isolated line receiver
- Computer-peripheral interfaces
- Microprocessor system interfaces
- Digital isolation for A/D and D/A conversion
- Switching power supply
- Instrument input/output isolation
- Ground loop elimination
- Pulse transformer replacement

CAUTION:

It is advised that normal static precautions be taken in handling and assembly of this component to prevent damage and/or degradation, which may be induced by ESD.

Features

- Available in dual, triple and quad channel configurations
- Bi-directional
- Wide supply voltage range 3.0V to 5.5V
- High-speed: 15 MBd typical, 10 MBd minimum
- 10 kV/ μ s minimum Common Mode Rejection (CMR) at $V_{cm} = 1000$ V
- LSTTL/TTL compatible
- Safety and regulatory approvals (Pending)
 - 2500Vrms for 1 min per UL1577
 - CSA Component Acceptance
 - IEC/EN/DIN EN 60747-5-2
- 16 Pin narrow-body SOIC package for triple and quad channel
- -40 to 100°C temperature range



Device Selection Guide

Device Number	Channel Configuration	Package
ACSL-6210	Dual, Bi-Directional`	8-pin Small Outline
ACSL-6300*	Triple, All-in-One	16-pin Small Outline
ACSL-6310*	Triple, Bi-Directional, 2/1	16-pin Small Outline
ACSL-6400	Quad, All-in-One	16-pin Small Outline
ACSL-6410*	Quad, Bi-Directional, 3/1	16-pin Small Outline
ACSL-6420*	Quad, Bi-Directional, 2/2	16-pin Small Outline

* Advanced Information

Ordering Information

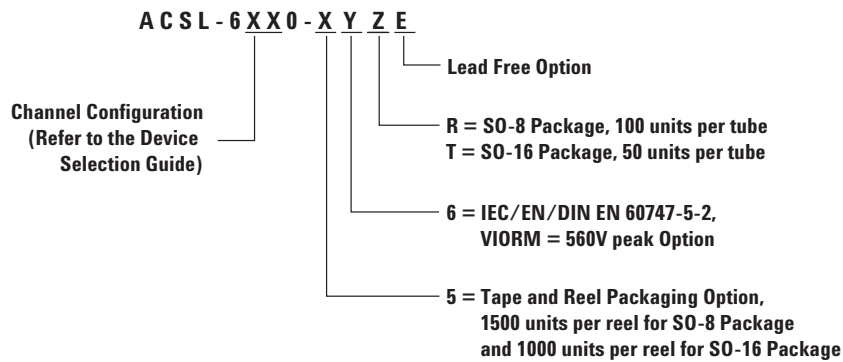

Pin Description

Symbol	Description	Symbol	Description
V_{DD1}	Power Supply 1	GND_1	Power Supply Ground 1
V_{DD2}	Power Supply 2	GND_2	Power Supply Ground 2
$ANODE_x$	LED Anode	NC	Not Connected
$CATHODE_x$	LED Cathode	V_{OX}	Output Signal

Truth Table (Positive Logic)

LED	OUTPUT
ON	L
OFF	H

Functional Diagrams

ACSL-6210 - Dual-Ch, Bi-Dir

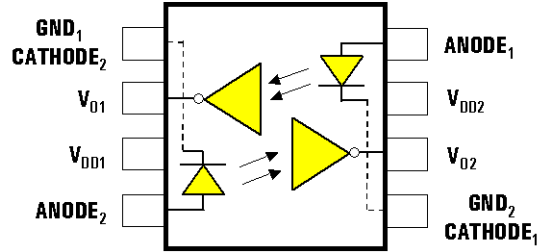

ACSL-6300 - Triple-Ch, All-in-One*

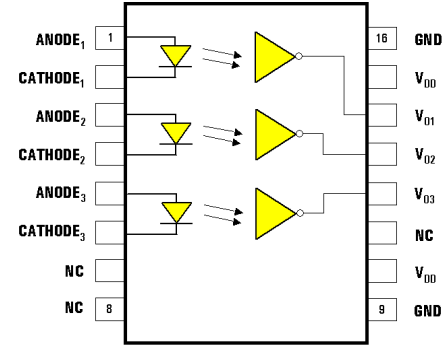

ACSL-6310 - Triple-Ch, Bi-Dir (2/1)*

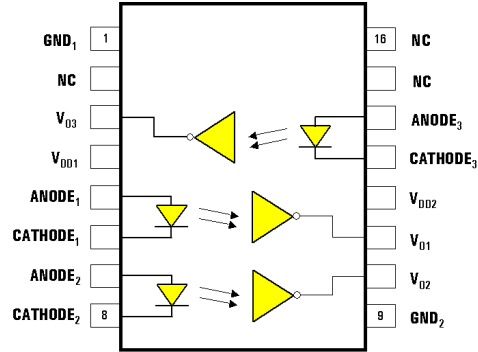

ACSL-6400 - Quad-Ch, All-in-One

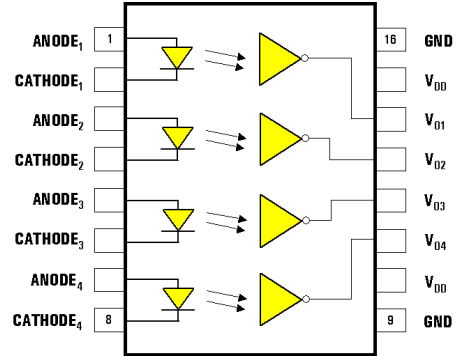

ACSL-6410 - Quad-Ch, Bi-Dir (3/1)*

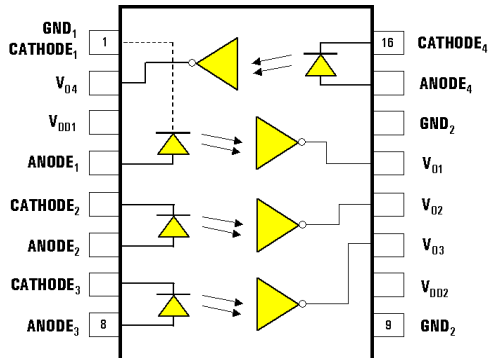

ACSL-6420 - Quad-Ch, Bi-Dir (2/2)*

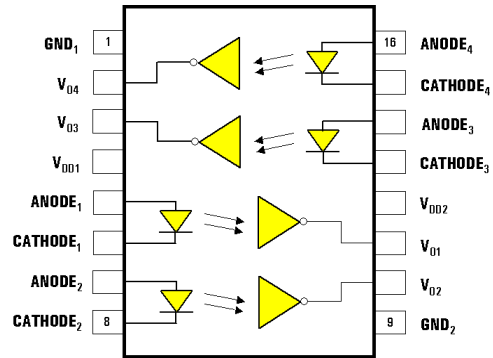

* Advanced Information

Package Outline Drawings

ACSL-6210 Small Outline SO-8 Package

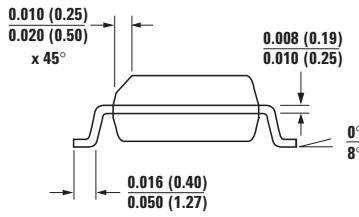
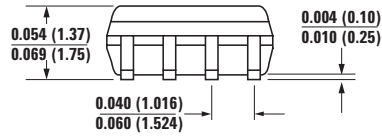
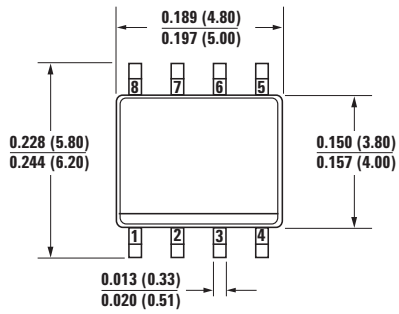

DIMENSIONS: INCHES (MILLIMETERS) MIN
MAX

ACSL-6300*, ACSL-6310*, ACSL-6400, ACSL-6410* and ACSL-6420* Small Outline SO-16 Package

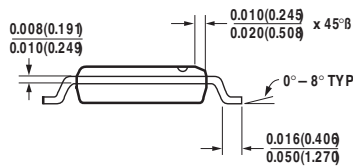
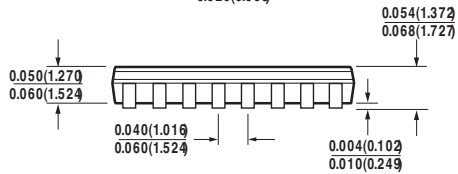
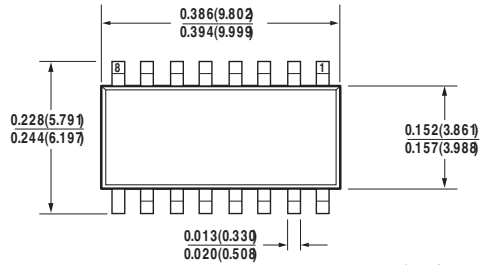

DIMENSIONS: INCHES (MILLIMETERS) MIN
MAX

Solder Reflow Temperature Profile

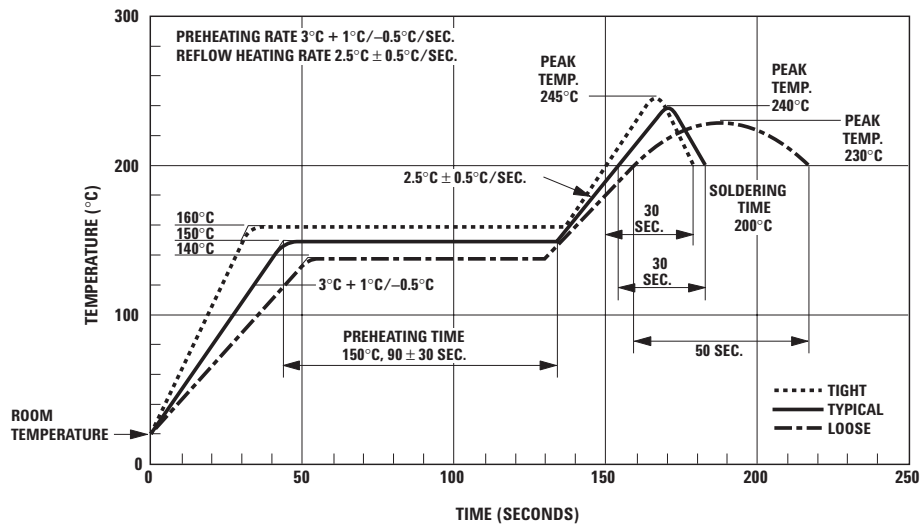

Pb-free IR Profile

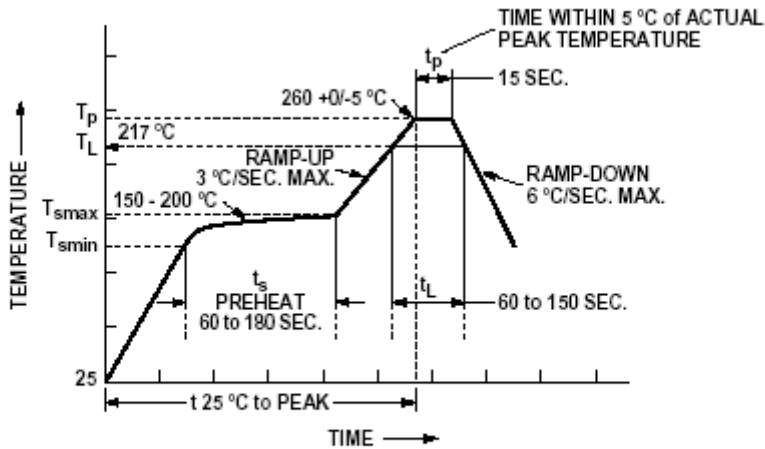

NOTES:
 THE TIME FROM 25°C TO PEAK TEMPERATURE = 8 MINUTES MAX.
 $T_{smax} = 200^{\circ}\text{C}$, $T_{smin} = 150^{\circ}\text{C}$

Regulatory Information

Insulation and Safety Related Specifications

Parameter	Symbol	Value	Units	Conditions
Minimum External Air Gap (Clearance)	L(I01)	4.9	mm	Measured from input terminals to output terminals, shortest distance through air
Minimum External Tracking (Creepage)	L(I02)	4.5	mm	Measured from input terminals to output terminals, shortest distance path through body
Minimum Internal Plastic Gap (Internal Clearance)		0.08	mm	Insulation thickness between emitter and detector; also known as distance through insulation
Tracking Resistance (Comparative Tracking Index)	CTI	175	Volts	DIN IEC 112/VDE0303 Part 1
Isolation Group		IIIa		Material Group (DIN VDE 0110, 1/89, Table 1)

IEC/EN/DIN EN 60747-5-2 Insulation Related Characteristics (Option X6X Only)

Description	Symbol	ACSL-6XX0-X6X	Units
Installation Classification per DIN VDE 0110/1.89, Table 1 for rated mains voltage $\leq 150V$ rms for rated mains voltage $\leq 300V$ rms		I-IV I-III	
Climatic Classification		55/100/21	
Pollution Degree (DIN VDE 0110/1.89)		2	
Maximum Working Insulation Voltage	V_{IORM}	560	V_{peak}
Input to Output Test Voltage, Method b * $V_{IORM} \times 1.875 = V_{PR}$, 100% Production Test with $t_m = 1$ sec, Partial Discharge < 5 pC	V_{PR}	1050	V_{peak}
Input to Output Test Voltage, Method a * $V_{IORM} \times 1.5 = V_{PR}$, Type and Sample Test, $T_m = 60$ sec, Partial Discharge < 5 pC	V_{PR}	840	V_{peak}
Highest Allowable Overvoltage * (Transient Overvoltage, $t_{ni} = 10$ sec)	V_{IOTM}	4000	V_{peak}
Safety Limiting Values (Maximum values allowed in the event of a failure)			
Case Temperature	T_S	175	$^{\circ}C$
Input Current	$I_{S,INPUT}$	150	mA
Output Power	$P_{S,OUTPUT}$	600	mW
Insulation Resistance at T_S , $V_{IO} = 500V$	R_{IO}	10^9	Ω

*Refer to the front of the optocoupler section of the current catalog, under Product Safety Regulations section, IEC/EN/DIN EN 60747-5-2, for a detailed description.

Note: Isolation characteristics are guaranteed only within the safety maximum ratings, which must be ensured by protective circuits in application.

Absolute Maximum Ratings

Parameter	Symbol	Min.	Max.	Units
Storage Temperature	T_s	-55	125	°C
Operating Temperature	T_A	-40	100	°C
Supply Voltage (1 Minute Maximum)	V_{DD1}, V_{DD2}		7	V
Reverse Input Voltage (Per Channel)	V_R		5	V
Output Voltage (Per Channel)	V_O		7	V
Average Forward Input Current ^[1] (Per Channel)	I_F		15	mA
Output Current (Per Channel)	I_O		50	mA
Input Power Dissipation ^[2] (Per Channel)	P_I		27	mW
Output Power Dissipation ^[2] (Per Channel)	P_O		60	mW

Recommended Operating Conditions

Parameter	Symbol	Min.	Max.	Units
Operating Temperature	T_A	-40	100	°C
Input Current, Low Level ^[3]	I_{FL}	0	250	μA
Input Current, High Level ^[4]	I_{FH}	7	15	mA
Supply Voltage	V_{DD1}, V_{DD2}	3.0	5.5	V
Fan Out (at $T_A = 1k\Omega$)	N		5	TTL Loads
Output Pull-up Resistor	R_L	330	4k	Ω

Notes:

1. Peaking circuits may produce transient input currents up to 50 mA, 50 ns max. pulse width, provided average current does not exceed its max. values.
2. Derate total package power dissipation, P_T linearly above +80°C free-air temperature at a rate of 5.45 mW/°C for the SO8 package. $P_T = \text{number of channels multiply by } (P_I + P_O)$. For SO16 package data, contact factory for assistance.
3. The off condition can be guaranteed by ensuring that $V_{FL} \leq 0.8V$.
4. The initial switching threshold is 7 mA or less. It is recommended that minimum 8 mA be used for best performance and to permit guardband for LED degradation.

Electrical Specifications

Over recommended operating range ($3.0V \leq V_{DD1} \leq 3.6V$, $3.0V \leq V_{DD2} \leq 3.6V$, $T_A = -40^\circ C$ to $+100^\circ C$) unless otherwise specified.

All typical specifications are at $T_A = +25^\circ C$, $V_{DD1} = V_{DD2} = +3.3V$.

Parameter	Symbol	Min.	Typ.	Max.	Units	Test Conditions
Input Threshold Current	I_{TH}		2.7	7.0	mA	$I_{OL(Sinking)} = 13 \text{ mA}$, $V_O = 0.6V$
High Level Output Current	I_{OH}		4.7	100.0	μA	$I_F = 250 \mu A$, $V_O = 3.3V$
Low Level Output Voltage	V_{OL}		0.36	0.68	V	$I_{OL(Sinking)} = 13 \text{ mA}$, $I_F = 7 \text{ mA}$
High Level Supply Current (per channel)	I_{DDH}		3.2	5.0	mA	$I_F = 0 \text{ mA}$
Low Level Supply Current (per channel)	I_{DDL}		4.6	7.5	mA	$I_F = 10 \text{ mA}$
Input Forward Voltage	V_F	1.25	1.52	1.80	V	$I_F = 10 \text{ mA}$, $T_A = 25^\circ C$
Input Reverse Breakdown Voltage	BV_R	5.0			V	$I_R = 10 \mu A$
Input Diode Temperature Coefficient	$\Delta V_F / \Delta T_A$		-1.8		mV/ $^\circ C$	$I_F = 10 \text{ mA}$
Input Capacitance	C_{IN}		80		pF	$f = 1 \text{ MHz}$, $V_F = 0V$

Switching Specifications

Over recommended operating range ($3.0V \leq V_{DD1} \leq 3.6V$, $3.0V \leq V_{DD2} \leq 3.6V$, $I_F = 8.0 \text{ mA}$, $T_A = -40^\circ C$ to $+100^\circ C$) unless otherwise specified.

All typical specifications are at $T_A = +25^\circ C$, $V_{DD1} = V_{DD2} = +3.3V$.

Parameter	Symbol	Min.	Typ.	Max.	Units	Test Conditions
Maximum Data Rate		10	15		MBd	$R_L = 350\Omega$, $C_L = 15 \text{ pF}$
Pulse Width	t_{PW}	100			ns	$R_L = 350\Omega$, $C_L = 15 \text{ pF}$
Propagation Delay Time to Logic High Output Level ^[5]	t_{PLH}		52	100	ns	$R_L = 350\Omega$, $C_L = 15 \text{ pF}$
Propagation Delay Time to Logic Low Output Level ^[6]	t_{PHL}		44	100	ns	$R_L = 350\Omega$, $C_L = 15 \text{ pF}$
Pulse Width Distortion $ t_{PHL} - t_{PLH} $	$ PWD $		8	35	ns	$R_L = 350\Omega$, $C_L = 15 \text{ pF}$
Propagation Delay Skew ^[7]	t_{PSK}			40	ns	$R_L = 350\Omega$, $C_L = 15 \text{ pF}$
Output Rise Time (10 – 90%)	t_R		35		ns	$R_L = 350\Omega$, $C_L = 15 \text{ pF}$
Output Fall Time (10 – 90%)	t_F		12		ns	$R_L = 350\Omega$, $C_L = 15 \text{ pF}$
Logic High Common Mode Transient Immunity ^[8]	$ CM_H $	10			kV/ μs	$V_{cm} = 1000V$, $I_F = 0 \text{ mA}$, $V_O = 2.0V$, $R_L = 350\Omega$, $T_A = 25^\circ C$
Logic Low Common Mode Transient Immunity ^[8]	$ CM_L $	10			kV/ μs	$V_{cm} = 1000V$, $I_F = 8 \text{ mA}$, $V_O = 0.8V$, $R_L = 350\Omega$, $T_A = 25^\circ C$

Notes:

- t_{PLH} is measured from the 4.0 mA level on the falling edge of the input pulse to the 1.5V level on the rising edge of the output pulse.
- t_{PHL} is measured from the 4.0 mA level on the rising edge of the input pulse to the 1.5V level on the falling edge of the output pulse.
- t_{PSK} is equal to the worst case difference in t_{PHL} and/or t_{PLH} that will be seen between units at any given temperature and specified test conditions.
- CM_H is the maximum common mode voltage slew rate that can be sustained while maintaining $V_O > 2.0V$. CM_L is the maximum common mode voltage slew rate that can be sustained while maintaining $V_O < 0.8V$. The common mode voltage slew rates apply to both rising and falling common mode voltage edges.

Electrical Specifications

Over recommended operating range ($4.5V \leq V_{DD1} \leq 5.5V$, $4.5V \leq V_{DD2} \leq 5.5V$, $T_A = -40^\circ C$ to $+100^\circ C$) unless otherwise specified.

All typical specifications are at $T_A = +25^\circ C$, $V_{DD1} = V_{DD2} = +5.0V$.

Parameter	Symbol	Min.	Typ.	Max.	Units	Test Conditions
Input Threshold Current	I_{TH}		2.7	7.0	mA	$I_{OL(Sinking)} = 13 \text{ mA}$, $V_O = 0.6V$
High Level Output Current	I_{OH}		3.8	100.0	μA	$I_F = 250 \mu A$, $V_O = 5.5V$
Low Level Output Voltage	V_{OL}		0.36	0.6	V	$I_{OL(Sinking)} = 13 \text{ mA}$, $I_F = 7 \text{ mA}$
High Level Supply Current (per channel)	I_{DDH}		4.3	7.5	mA	$I_F = 0 \text{ mA}$
Low Level Supply Current (per channel)	I_{DDL}		5.8	10.5	mA	$I_F = 10 \text{ mA}$
Input Forward Voltage	V_F	1.25	1.52	1.8	V	$I_F = 10 \text{ mA}$, $T_A = 25^\circ C$
Input Reverse Breakdown Voltage	BV_R	5.0			V	$I_R = 10 \mu A$
Input Diode Temperature Coefficient	$\Delta V_F / \Delta T_A$		-1.8		mV/ $^\circ C$	$I_F = 10 \text{ mA}$
Input Capacitance	C_{IN}		80		pF	$f = 1 \text{ MHz}$, $V_F = 0V$

Switching Specifications

Over recommended operating range ($4.5V \leq V_{DD1} \leq 5.5V$, $4.5V \leq V_{DD2} \leq 5.5V$, $I_F = 8.0 \text{ mA}$, $T_A = -40^\circ C$ to $+100^\circ C$) unless otherwise specified.

All typical specifications are at $T_A = +25^\circ C$, $V_{DD1} = V_{DD2} = +5.0V$.

Parameter	Symbol	Min.	Typ.	Max.	Units	Test Conditions
Maximum Data Rate		10	15		MBd	$R_L = 350\Omega$, $C_L = 15 \text{ pF}$
Pulse Width	t_{PW}	100			ns	$R_L = 350\Omega$, $C_L = 15 \text{ pF}$
Propagation Delay Time to Logic High Output Level ^[5]	t_{PLH}		46	100	ns	$R_L = 350\Omega$, $C_L = 15 \text{ pF}$
Propagation Delay Time to Logic Low Output Level ^[6]	t_{PHL}		43	100	ns	$R_L = 350\Omega$, $C_L = 15 \text{ pF}$
Pulse Width Distortion $ t_{PHL} - t_{PLH} $	$ PWD $		5	35	ns	$R_L = 350\Omega$, $C_L = 15 \text{ pF}$
Propagation Delay Skew ^[7]	t_{PSK}			40	ns	$R_L = 350\Omega$, $C_L = 15 \text{ pF}$
Output Rise Time (10 – 90%)	t_R		30		ns	$R_L = 350\Omega$, $C_L = 15 \text{ pF}$
Output Fall Time (10 – 90%)	t_F		12		ns	$R_L = 350\Omega$, $C_L = 15 \text{ pF}$
Logic High Common Mode Transient Immunity ^[8]	$ CM_H $	10			kV/ μs	$V_{cm} = 1000V$, $I_F = 0 \text{ mA}$, $V_O = 2.0V$, $R_L = 350\Omega$, $T_A = 25^\circ C$
Logic Low Common Mode Transient Immunity ^[8]	$ CM_L $	10			kV/ μs	$V_{cm} = 1000V$, $I_F = 8 \text{ mA}$, $V_O = 0.8V$, $R_L = 350\Omega$, $T_A = 25^\circ C$

Notes:

- t_{PLH} is measured from the 4.0 mA level on the falling edge of the input pulse to the 1.5V level on the rising edge of the output pulse.
- t_{PHL} is measured from the 4.0 mA level on the rising edge of the input pulse to the 1.5V level on the falling edge of the output pulse.
- t_{PSK} is equal to the worst case difference in t_{PHL} and/or t_{PLH} that will be seen between units at any given temperature and specified test conditions.
- CM_H is the maximum common mode voltage slew rate that can be sustained while maintaining $V_O > 2.0V$. CM_L is the maximum common mode voltage slew rate that can be sustained while maintaining $V_O < 0.8V$. The common mode voltage slew rates apply to both rising and falling common mode voltage edges.

Package Characteristics

All specifications are at $T_A = +25^\circ\text{C}$.

Parameter		Symbol	Min.	Typ.	Max.	Units	Test Conditions
Input-Output Momentary Withstand Voltage ^[9]	S08	V_{ISO}	2500			V_{RMS}	RH \leq 50%, t = 1 min
	S016	V_{ISO}	2500				RH \leq 50%, t = 1 min
Input-Output Insulation ^{[10][11]}	S08	I_{I-O}			5	μA	45% RH, t = 5 sec, $V_{I-O} = 3\text{kV DC}$
	S016	I_{I-O}			5		45% RH, t = 5 sec, $V_{I-O} = 3\text{kV DC}$
Input-Output Resistance ^[10]	S08	R_{I-O}	10^9	10^{11}		Ω	$V_{I-O} = 500\text{V DC}$
	S016	R_{I-O}	10^9	10^{11}			$V_{I-O} = 500\text{V DC}$
Input-Output Capacitance ^[10]	S08	C_{I-O}		0.7		pF	f = 1 MHz
	S016	C_{I-O}		0.7			f = 1 MHz
Input-Input Insulation Leakage Current ^[12]	S08	I_{I-I}		0.005		μA	RH \leq 45%, t = 5 sec, $V_{I-I} = 500\text{V}$
	S016	I_{I-I}		0.005			RH \leq 45%, t = 5 sec, $V_{I-I} = 500\text{V}$
Input-Input Resistance ^[12]	S08	R_{I-I}		10^{11}		Ω	RH \leq 45%, t = 5 sec, $V_{I-I} = 500\text{V}$
	S016	R_{I-I}		10^{11}			RH \leq 45%, t = 5 sec, $V_{I-I} = 500\text{V}$
Input-Input Capacitance ^[12]	S08	C_{I-I}		0.1		pF	f = 1 MHz
	S016	C_{I-I}		0.12			f = 1 MHz

Electrostatic Discharge Sensitivity

This product has been tested for electrostatic sensitivity to the limits stated in the specifications. However, Agilent recommends that all integrated circuits be handled with appropriate care to avoid damage. Damage caused by inappropriate handling or storage could range from performance degradation to complete failure.

Notes:

- V_{ISO} is a dielectric voltage rating that should not be interpreted as an input-output continuous voltage rating. For continuous voltage rating, refer to the IEC/EN/DIN EN 60747-5-2 Insulation Characteristics Table (if applicable), the equipment level safety specification or Agilent Application Note 1074 entitled "Optocoupler Input-Output Endurance Voltage."
- Measured between each input pair shorted together and all output connections for that channel shorted together.
- In accordance with UL1577, each optocoupler is proof tested by applying an insulation test voltage $\geq 3000\text{ Vrms}$ for 1 sec (leakage detection current limit, $I_{I-O} \leq 5\ \mu\text{A}$). This test is performed before the 100% production test for partial discharge (Method b) shown in the IEC/EN/DIN EN 60747-5-2 Insulation Characteristics Table, if applicable.
- Measured between inputs with the LED anode and cathode shorted together.

www.agilent.com/semiconductors

For product information and a complete list of distributors, please go to our web site.

For technical assistance call:

Americas/Canada: +1 (800) 235-0312 or (916) 788-6763

Europe: +49 (0) 6441 92460

China: 10800 650 0017

Hong Kong: (65) 6756 2394

India, Australia, New Zealand: (65) 6755 1939

Japan: (+81 3) 3335-8152(Domestic/International), or 0120-61-1280(Domestic Only)

Korea: (65) 6755 1989

Singapore, Malaysia, Vietnam, Thailand, Philippines, Indonesia: (65) 6755 2044

Taiwan: (65) 6755 1843

Data subject to change.

Copyright © 2004 Agilent Technologies, Inc.

November 1, 2004

5989-1343EN



Agilent Technologies