

# ACPL-M75L

Single-channel High Speed 15 MBd CMOS optocoupler with Glitch-Free Power-Up Feature



## Data Sheet



Lead (Pb) Free  
RoHS 6 fully compliant

RoHS 6 fully compliant options available;  
-xxxE denotes a lead-free product

### Description

The ACPL-M75L (single-channel) is 15 MBd CMOS optocouplers in SOIC-5 package. The optocouplers utilize the latest CMOS IC technology to achieve outstanding performance with very low power consumption. Basic building blocks of ACPL-M75L are high speed LEDs and CMOS detector ICs. Each detector incorporates an integrated photodiode, a high speed transimpedance amplifier, and a voltage comparator with an output driver.

### Component Image

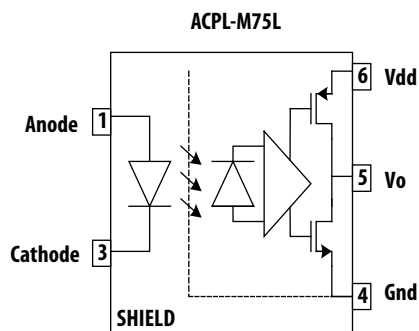

A 0.1uF bypass capacitor must be connected between pins 4 and 6.

### TRUTH TABLE

LED	V <sub>O</sub> , OUTPUT
OFF	H
ON	L

### Features

- +3.3V and +5 V CMOS compatibility
- 25ns max. pulse width distortion
- 55ns max. propagation delay
- 40ns max. propagation delay skew
- High speed: 15 MBd min
- 10 kV/μs minimum common mode rejection
- -40 to 105°C temperature range
- Glitch-Free Power-UP Feature
- Safety and regulatory approvals:
  - UL recognized: 3750 V rms for 1 min. per UL 1577
  - CSA component acceptance Notice #5
  - IEC/EN/DIN EN 60747-5-2 approved Option 060

### Applications

- Digital field bus isolation:
  - RS485, RS232, CANbus
- Multiplexed data transmission
- Computer peripheral interface
- Microprocessor system interface
- DC/DC converter
- Servo Motor

**CAUTION:** It is advised that normal static precautions be taken in handling and assembly of this component to prevent damage and/or degradation which may be induced by ESD.

## Ordering Information

ACPL-M75L will be UL Recognized with 3750 Vrms for 1 minute per UL1577.

Part number	Option		Surface Mount	Gull Wing	Tape & Reel	UL 5000 Vrms/ 1 Minute rating	IEC/EN/DIN EN 60747-5-2	Quantity
	RoHS Compliant	Package						
ACPL-M75L	-000E	SO-5	X					100 per tube
	-500E		X		X			1500 per reel
	-060E		X				X	100 per tube
	-560E		X		X		X	1500 per reel

To order, choose a part number from the part number column and combine with the desired option from the option column to form an order entry.

Example 1:

ACPL-M75L-500E to order product of Small Outline SO-5 package in Tape and Reel packaging in RoHS compliant.

Example 2:

ACPL-M75L-000E to order product of Small Outline SO-5 package in tube packaging and in RoHS compliant.

Option datasheets are available. Contact your Avago sales representative or authorized distributor for information.

## Package Dimensions

### ACPL-M75L (JEDEC MO-155 Package)

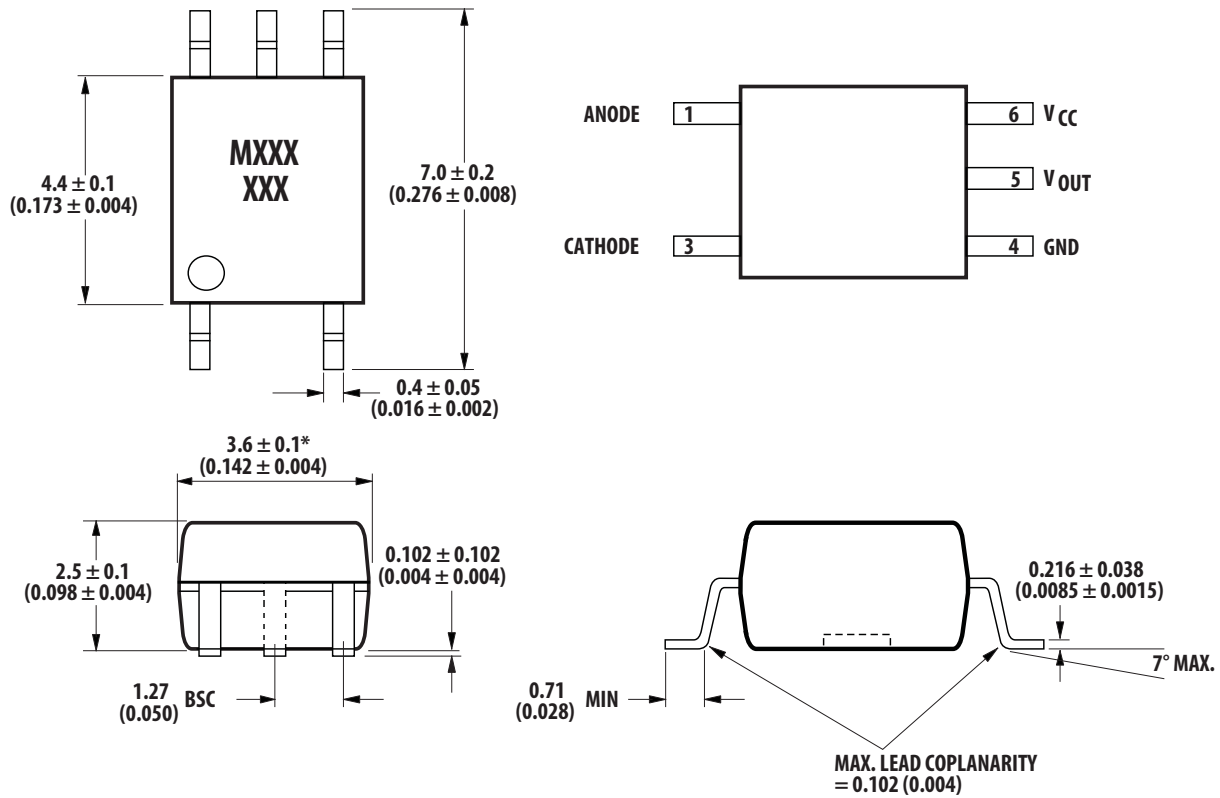

DIMENSIONS IN MILLIMETERS (INCHES)

\* MAXIMUM MOLD FLASH ON EACH SIDE IS 0.15 mm (0.006)

NOTE: FLOATING LEAD PROTRUSION IS 0.15 mm (6 mils) MAX.

## Land Pattern Recommendation

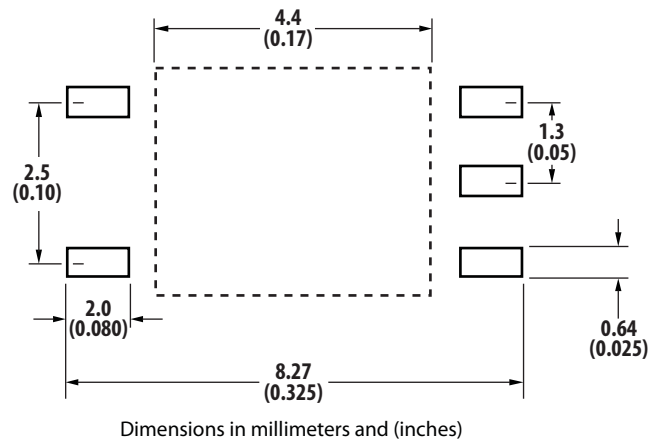

## Solder Reflow Thermal Profile

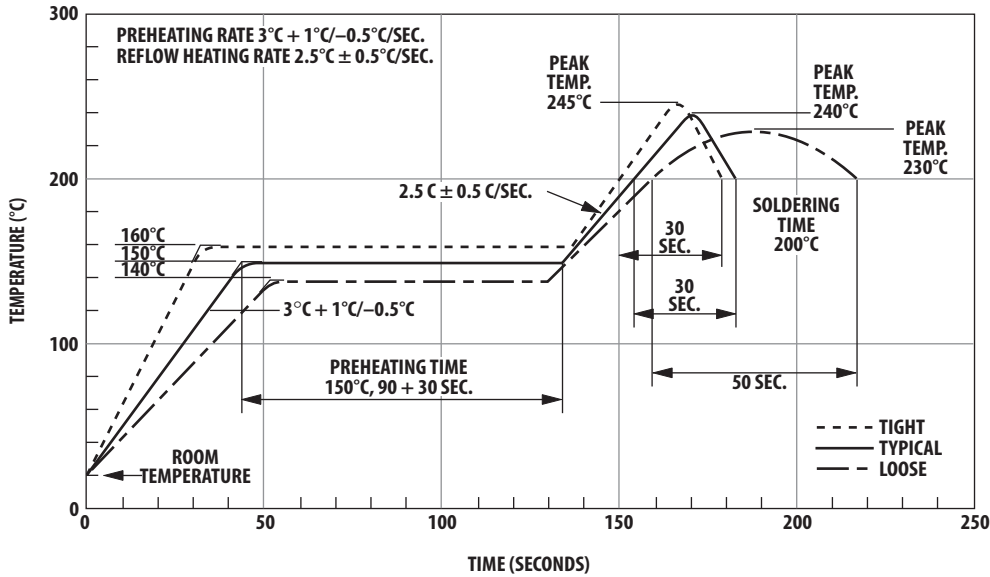

Non-halide flux should be used.

## Recommended Pb-Free IR Flow

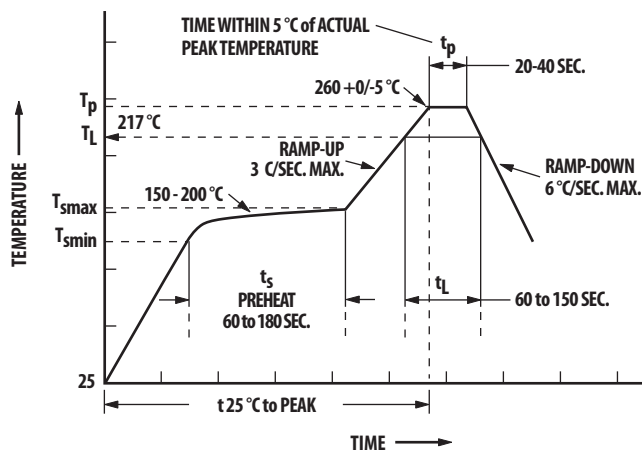

Notes:

The time from 25 °C to peak temperature = 8 minutes max.

$T_{smax} = 200^{\circ}\text{C}$ ,  $T_{smin} = 150^{\circ}\text{C}$

Non-halide flux should be used

## Regulatory Information

The ACPL-M75L has been approved by the following organizations:

### UL

Recognized under UL 1577, component recognition program, File E55361.

### CSA

Approved under CSA Component Acceptance Notice #5, File CA88324.

### IEC/EN/DIN EN 60747-5-2

Approved under:

IEC 60747-5-2:1997 + A1:2002

EN 60747-5-2:2001 + A1:2002

DIN EN 60747-5-2 (VDE 0884Teil 2):2003-01

(Option 060 only)

## Insulation and Safety Related Specifications

Parameter	Symbol	Value	Units	Conditions
Minimum External Air Gap (Clearance)	L(I01)	$\geq 5$	mm	Measured from input terminals to output terminals, shortest distance through air.
Minimum External Tracking (Creepage)	L(I02)	$\geq 5$	mm	Measured from input terminals to output terminals, shortest distance path along body.
Minimum Internal Plastic Gap (Internal Clearance)		0.08	mm	Insulation thickness between emitter and detector; also known as distance through insulation.
Tracking Resistance (Comparative Tracking Index)	CTI	$\geq 175$	Volts	DIN IEC 112/VDE 0303 Part 1
Isolation Group		IIIa		Material Group (DIN VDE 0110, 1/89, Table 1)

All Avago Technologies data sheets report the creepage and clearance inherent to the optocoupler component itself. These dimensions are needed as a starting point for the equipment designer when determining the circuit insulation requirements. However, once mounted on a printed circuit board, minimum creepage and clearance requirements must be met as specified for individual equipment standards. For creepage, the shortest distance

path along the surface of a printed circuit board between the solder fillets of the input and output leads must be considered. There are recommended techniques such as grooves and ribs which may be used on a printed circuit board to achieve desired creepage and clearances. Creepage and clearance distances will also change depending on factors such as pollution degree and insulation level.

### IEC/EN/DIN EN 60747-5-2 Insulation Related Characteristics (Option 060)

Description	Symbol	option 060	Units
Installation classification per DIN VDE 0110/1.89, Table 1 for rated mains voltage $\leq 150$ V rms for rated mains voltage $\leq 300$ V rms		I-IV I-III	
Climatic Classification		55/105/21	
Pollution Degree (DIN VDE 0110/1.89)		2	
Maximum Working Insulation Voltage	$V_{IORM}$	560	$V_{PEAK}$
Input to Output Test Voltage, Method b† $V_{IORM} \times 1.875 = V_{PR}$ , 100% Production Test with $t_m = 1$ sec, Partial Discharge $< 5$ pC	$V_{PR}$	1050	$V_{PEAK}$
Input to Output Test Voltage, Method a† $V_{IORM} \times 1.5 = V_{PR}$ , Type and Sample Test, $t_m = 60$ sec, Partial Discharge $< 5$ pC	$V_{PR}$	840	$V_{PEAK}$
Highest Allowable Overvoltage† (Transient Overvoltage, $t_{ini} = 10$ sec)	$V_{IOTM}$	4000	$V_{PEAK}$
Safety Limiting Values (Maximum values allowed in the event of a failure, also see Thermal Derating curve, Figure 11.)			
Case Temperature	$T_S$	150	$^{\circ}C$
Input Current	$I_{S, INPUT}$	150	mA
Output Power	$P_{S, OUTPUT}$	600	mW
Insulation Resistance at $T_S$ , $V_{10} = 500$ V	$R_{IO}$	$\geq 10^9$	$\Omega$

## Absolute Maximum Ratings

Parameter	Symbol	Min.	Max.	Units
Storage Temperature	$T_S$	-55	+125	°C
Ambient Operating Temperature	$T_A$	-40	+105	°C
Supply Voltages	$V_{DD}$	0	6.0	Volts
Output Voltage	$V_O$	-0.5	$V_{DD} + 0.5$	Volts
Average Forward Input Current	$I_F$	-	10.0	mA
Average Output Current	$I_O$	-	10.0	mA
Lead Solder Temperature		260°C for 10 sec., 1.6 mm below seating plane		
Solder Reflow Temperature Profile		See Solder Reflow Temperature Profile Section		

## Recommended Operating Conditions

Parameter	Symbol	Min.	Max.	Units
Ambient Operating Temperature	$T_A$	-40	+105	°C
Supply Voltages	$V_{DD}$	4.5	5.5	V
		3.0	3.6	V
Input Current (ON)	$I_F$	4	8	mA
Forward Input Voltage (OFF)	$V_{F(OFF)}$	0	0.8	V
Supply Voltage Slew Rate <sup>[1]</sup>	$S_R$	0.5	500	V/ms

## Electrical Specifications

Over recommended temperature ( $T_A = -40^\circ\text{C}$  to  $+105^\circ\text{C}$ ),  $3.0\text{V} \leq V_{DD} \leq 3.6\text{V}$  and  $4.5\text{V} \leq V_{DD} \leq 5.5\text{V}$ .

All typical specifications are at  $T_A = +25^\circ\text{C}$ ,  $V_{DD} = +3.3\text{V}$ .

Parameter	Symbol	Min.	Typ.	Max.	Units	Test Conditions
Input Forward Voltage	$V_F$	1.3	1.5	1.8	V	$I_F = 6\text{mA}$
Input Reverse Breakdown Voltage	$BV_R$	5.0			V	$I_R = 10\ \mu\text{A}$
Logic High Output Voltage	$V_{OH}$	$V_{DD} - 1$	$V_{DD} - 0.3$		V	$I_F = 0, I_O = -4\text{mA}, V_{DD} = 3.3\text{V}$
		$V_{DD} - 1$	$V_{DD} - 0.2$		V	$I_F = 0, I_O = -4\text{mA}, V_{DD} = 5\text{V}$
Logic Low Output Voltage	$V_{OL}$		0.2	0.8	V	$I_F = 6\text{mA}, I_O = 4\text{mA}, V_{DD} = 3.3\text{V}$
			0.35	0.8	V	$I_F = 6\text{mA}, I_O = 4\text{mA}, V_{DD} = 5\text{V}$
Input Threshold Current	$I_{TH}$		1	3	mA	$I_{OL} = 20\ \mu\text{A}$
Logic Low Output Supply Current	$I_{DDL}$		4.5	6.5	mA	$I_F = 6\text{mA}$
Logic High Output Supply Current	$I_{DDH}$		4	6	mA	$I_F = 0$

## Switching Specifications

Over recommended temperature ( $T_A = -40^\circ\text{C}$  to  $+105^\circ\text{C}$ ),  $3.0\text{V} \leq V_{DD} \leq 3.6\text{V}$  and  $4.5\text{V} \leq V_{DD} \leq 5.5\text{V}$ .

All typical specifications are at  $T_A = +25^\circ\text{C}$ ,  $V_{DD} = +3.3\text{V}$ .

Parameter	Symbol	Min.	Typ.	Max.	Units	Test Conditions
Propagation Delay Time to Logic Low Output <sup>[2]</sup>	$t_{PHL}$		25	55	ns	$I_F = 6\text{mA}$ , $C_L = 15\text{pF}$ CMOS Signal Levels
Propagation Delay Time to Logic High Output <sup>[2]</sup>	$t_{PLH}$		21	55	ns	$I_F = 6\text{mA}$ , $C_L = 15\text{pF}$ , CMOS Signal Levels
Pulse Width	$t_{PW}$	66.7			ns	
Pulse Width Distortion <sup>[3]</sup>	$ PWD $	0	4	25	ns	$I_F = 6\text{mA}$ , $C_L = 15\text{pF}$ , CMOS Signal Levels
Propagation Delay Skew <sup>[4]</sup>	$t_{PSK}$			40	ns	$I_F = 6\text{mA}$ , $C_L = 15\text{pF}$ CMOS Signal Levels
Output Rise Time (10% – 90%)	$t_R$		3.5		ns	$I_F = 6\text{mA}$ , $C_L = 15\text{pF}$ CMOS Signal Levels
Output Fall Time (90% - 10%)	$t_F$		3.5		ns	$I_F = 6\text{mA}$ , $C_L = 15\text{pF}$ CMOS Signal Levels
Common Mode Transient Immunity at Logic High Output <sup>[5]</sup>	$ CMH $	10	15		kV/ $\mu\text{s}$	$V_{CM} = 1000\text{V}$ , $T_A = 25^\circ\text{C}$ , $I_F = 0\text{mA}$ (Figure 18)
		30	35		kV/ $\mu\text{s}$	Using Avago's Application Circuit (Figure 13)
Common Mode Transient Immunity at Logic Low Output <sup>[6]</sup>	$ CML $	10	15		kV/ $\mu\text{s}$	$V_{CM} = 1000\text{V}$ , $T_A = 25^\circ\text{C}$ , $I_F = 6\text{mA}$ (Figure 18)
		30	35		kV/ $\mu\text{s}$	Using Avago's Application Circuit (Figure 13)

## Package Characteristics

All Typical at  $T_A = 25^\circ\text{C}$ .

Parameter	Symbol	Min.	Typ.	Max.	Units	Test Conditions
Input-Output Insulation	$I_{I-O}$			1.0	$\mu\text{A}$	45% RH, $t = 5\text{s}$ $V_{I-O} = 3\text{kV DC}$ , $T_A = 25^\circ\text{C}$
Input-Output Momentary Withstand Voltage	$V_{ISO}$	3750			V <sub>rms</sub>	RH $\leq 50\%$ , $t = 1\text{min.}$ , $T_A = 25^\circ\text{C}$
Input-Output Resistance	$R_{I-O}$		$10^{12}$		$\Omega$	$V_{I-O} = 500\text{V dc}$
Input-Output Capacitance	$C_{I-O}$		0.6		pF	$f = 1\text{MHz}$ , $T_A = 25^\circ\text{C}$

Notes:

1. Slow rate of supply voltage ramping is recommended to ensure no glitch more than 1V to appear at the output pin.
2.  $t_{PHL}$  propagation delay is measured from the 50%  $V_{DD}$  level on the rising edge of the input pulse to the 50%  $V_{DD}$  level of the falling edge of the  $V_O$  signal.  $t_{PLH}$  propagation delay is measured from the 50%  $V_{DD}$  level on the falling edge of the input pulse to the 50%  $V_{DD}$  level of the rising edge of the  $V_O$  signal.
3. PWD is defined as  $|t_{PHL} - t_{PLH}|$ .
4.  $t_{PSK}$  is equal to the magnitude of the worst case difference in  $t_{PHL}$  and/or  $t_{PLH}$  that will be seen between units at any given temperature within the recommended operating conditions.
5.  $CM_H$  is the maximum tolerable rate of rise of the common mode voltage to assure that the output will remain in a high logic state.
6.  $CM_L$  is the maximum tolerable rate of fall of the common mode voltage to assure that the output will remain in a low logic state.

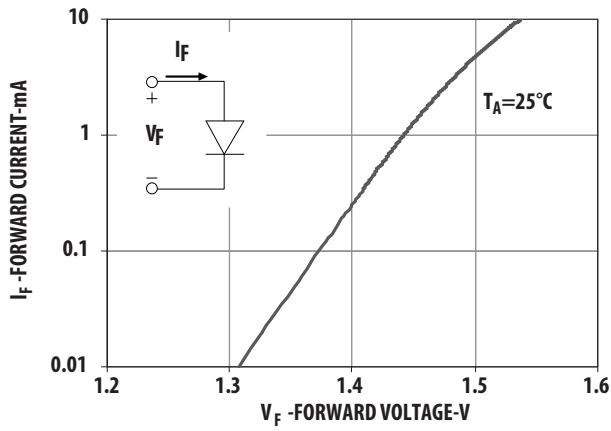

Figure 1. Typical input diode forward characteristic.

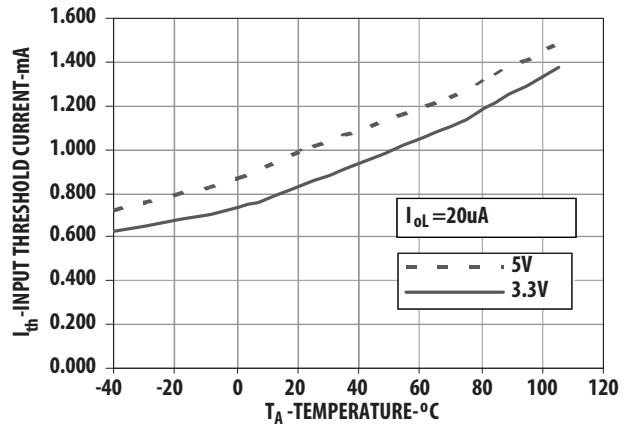

Figure 2. Typical input threshold current vs. temperature.

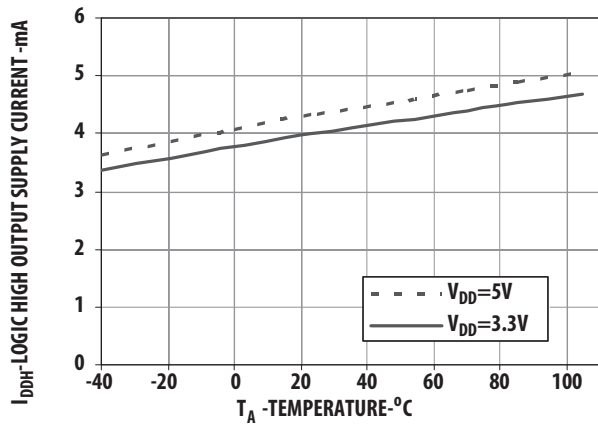

Figure 3. Typical logic high O/P supply current vs. temperature.

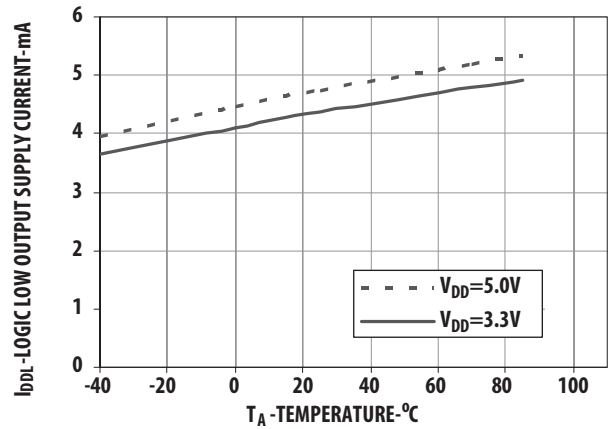

Figure 4. Typical logic low O/P supply current vs. temperature.

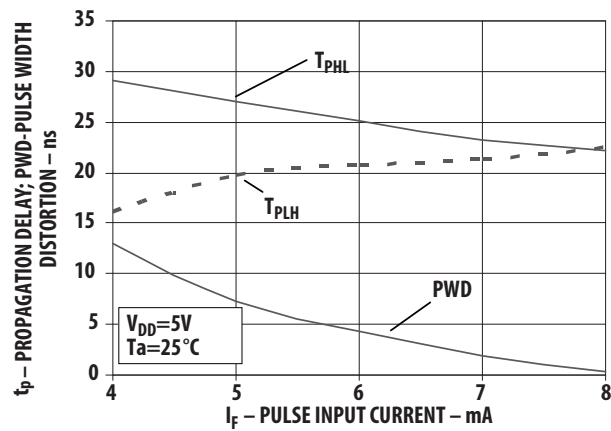

Figure 5. Typical switching speed vs. pulse input current at 5V supply voltage.

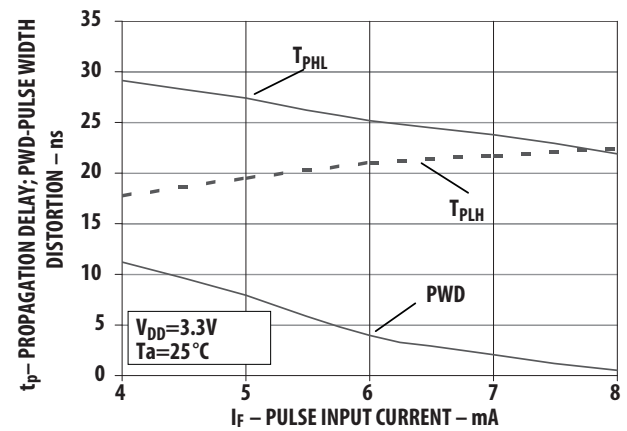

Figure 6. Typical switching speed vs. pulse input current at 3.3V supply voltage.



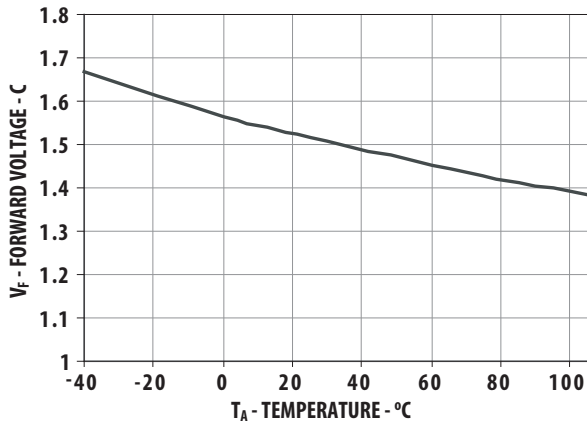

Figure 7. Typical  $V_F$  vs. temperature.

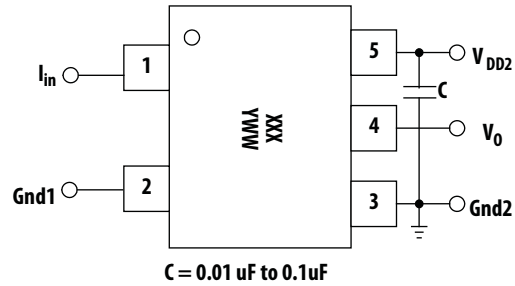

Figure 8. Recommended printed circuit board layout

## Application Information

### Bypassing and PC Board Layout

The ACPL-M75L optocoupler is extremely easy to use. ACPL-M75L provides CMOS logic output due to the high-speed CMOS IC technology used.

The external components required for proper operation are the input limiting resistor and the output bypass capacitor. Capacitor values should be between  $0.01 \mu\text{F}$  and  $0.1 \mu\text{F}$ .

For each capacitor, the total lead length between both ends of the capacitor and the power-supply pins should not exceed 20 mm.

### Propagation Delay, Pulse-Width Distortion and Propagation Delay Skew

Propagation delay is a figure of merit which describes how quickly a logic signal propagates through a system. The propagation delay from low to high ( $t_{PLH}$ ) is the amount of time required for an input signal to propagate to the output, causing the output to change from low to high.

Similarly, the propagation delay from high to low ( $t_{PHL}$ ) is the amount of time required for the input signal to propagate to the output, causing the output to change from high to low (see Figure 9).

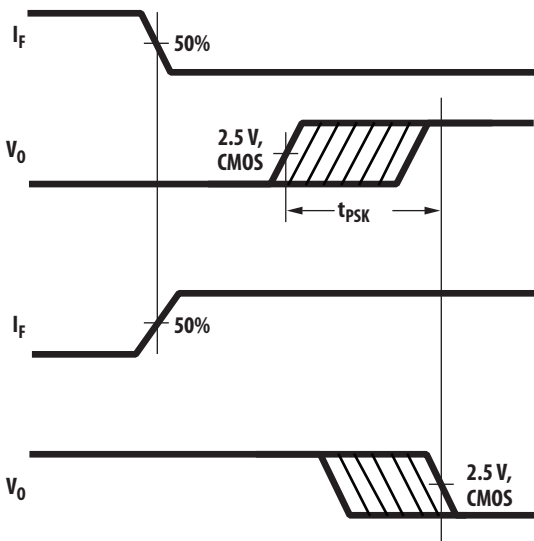

Figure 9. Propagation delay and skew waveform

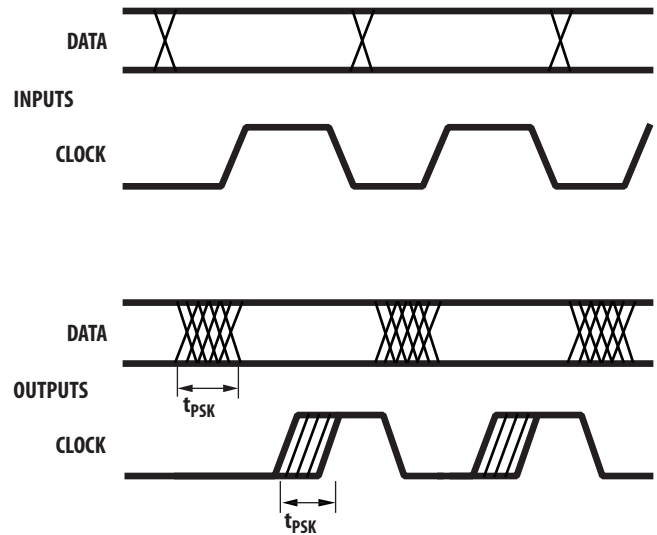

Figure 10. Parallel data transmission example

Pulse-width distortion (PWD) results when  $t_{PLH}$  and  $t_{PHL}$  differ in value. PWD is defined as the difference between  $t_{PLH}$  and  $t_{PHL}$  and often PWD determines the maximum data rate capability of a transmission system. PWD can be expressed in percent by dividing the PWD (in ns) by the minimum pulse width (in ns) being transmitted. Typically, PWD on the order of 20-30% of the minimum pulse width is tolerable; the exact figure depends on the particular application (RS232, RS422, T-1, etc.).

Propagation delay skew,  $t_{PSK}$ , is an important parameter to consider in parallel data applications where synchronization of signals on parallel data lines is a concern.

If the parallel data is being sent through a group of optocouplers, differences in propagation delays will cause the data to arrive at the outputs of the optocouplers at different times. If this difference in propagation delays is large enough, it will determine the maximum rate at which parallel data can be sent through the optocouplers.

Propagation delay skew is defined as the difference between the minimum and maximum propagation delays, either  $t_{PLH}$  or  $t_{PHL}$ , for any given group of optocouplers which are operating under the same conditions (i.e., the same supply voltage, output load, and operating temperature). As illustrated in Figure 10, if the inputs of a group of optocouplers are switched either ON or OFF at the same time,  $t_{PSK}$  is the difference between the shortest propagation delay, either  $t_{PLH}$  or  $t_{PHL}$ , and the longest propagation delay, either  $t_{PLH}$  or  $t_{PHL}$ . As mentioned earlier,  $t_{PSK}$  can determine the maximum parallel data transmission rate.

Figure 10 is the timing diagram of a typical parallel data application with both the clock and the data lines being sent through optocouplers. The figure shows data and clock signals at the inputs and outputs of the optocouplers. To obtain the maximum data transmission rate, both

edges of the clock signal are being used to clock the data; if only one edge were used, the clock signal would need to be twice as fast.

Propagation delay skew represents the uncertainty of where an edge might be after being sent through an optocoupler. Figure 10 shows that there will be uncertainty in both the data and the clock lines. It is important that these two areas of uncertainty not overlap, otherwise the clock signal might arrive before all of the data outputs have settled, or some of the data outputs may start to change before the clock signal has arrived.

From these considerations, the absolute minimum pulse width that can be sent through optocouplers in a parallel application is twice  $t_{PSK}$ . A cautious design should use a slightly longer pulse width to ensure that any additional uncertainty in the rest of the circuit does not cause a problem.

The  $t_{PSK}$  specified optocouplers offer the advantages of guaranteed specifications for propagation delays, pulse-width distortion and propagation delay skew over the recommended temperature, and power supply ranges.

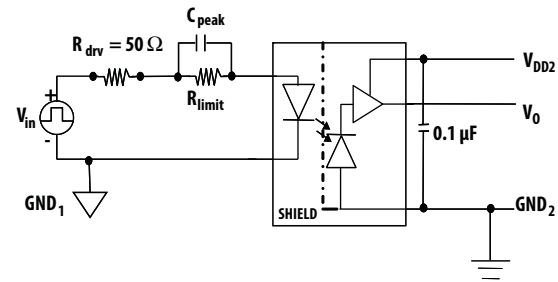
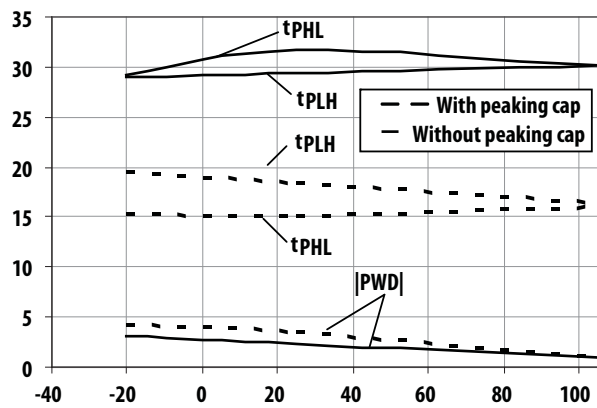
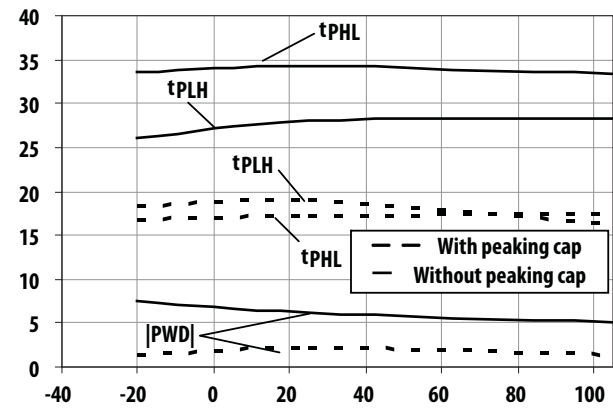

Figure 11. Connection of peaking capacitor ( $C_{peak}$ ) in parallel of the input limiting resistor ( $R_{limit}$ ) to improve speed performance



(i)  $V_{DD}=5V$ ,  $C_{peak}=100pF$ ,  $R_{imit}=530\Omega$



(ii)  $V_{DD}=3.3V$ ,  $C_{peak}=100pF$ ,  $R_{imit}=250\Omega$

Figure 12. Improvement of  $t_p$  and PWD with added 100pF peaking capacitor in parallel of input limiting resistor.

## Powering Sequence

$V_{DD}$  needs to achieve a minimum level of 3V before powering up the output connecting component.

## Input Limiting Resistors

ACPL-M75L is direct current driven (Figure 8), and thus eliminate the need for input power supply. To limit the amount of current flowing through the LED, it is recommended that a 530ohm resistor is connected in series with anode of LED (i.e. Pin 1 for ACPL-M75L) at 5V input signal. At 3.3V input signal, it is recommended to connect 250Ω resistor in series with anode of LED. The recommended limiting resistors is based on the assumption that the driver output impedance is 50Ω (as shown in Figure 11).

## Speed Improvement

A peaking capacitor can be placed across the input current limit resistor (Figure 11) to achieve enhanced speed performance. The value of the peaking cap is dependent to the rise and fall time of the input signal and supply voltages and LED input driving current ( $I_f$ ). Figure 12 shows significant improvement of propagation delay and pulse with distortion with added peak capacitor at driving current of 6mA for both 3.3V and 5V power supply.

## Common Mode Rejection for ACPL-M75L

Figure 13 shows the recommended drive circuit for the ACPL-M75L for optimal common-mode rejection performance. Two LED-current setting resistors are used instead of one. This is to balance the common mode impedance at LED anode and cathode. Common-mode transients can capacitively couple from the LED anode (or cathode) to the output-side ground causing current to be shunted away from the LED (which can be bad if the LED is on) or

conversely cause current to be injected into the LED (bad if the LED is meant to be off). Figure 14 shows the parasitic capacitances which exists between LED anode/cathode and output ground ( $C_{LA}$  and  $C_{LC}$ ). Also shown in Figure 14 on the input side is an AC-equivalent circuit.

Table 1 indicates the directions of  $I_{LP}$  and  $I_{LN}$  flow depending on the direction of the common-mode transient. For transients occurring when the LED is on, common-mode rejection ( $CM_L$ , since the output is in the “low” state) depends upon the amount of LED current drive ( $I_f$ ). For conditions where  $I_f$  is close to the switching threshold ( $I_{TH}$ ),  $CM_L$  also depends on the extent which  $I_{LP}$  and  $I_{LN}$  balance each other. In other words, any condition where common-mode transients cause a momentary decrease in  $I_f$  (i.e. when  $dV_{CM}/dt > 0$  and  $|I_{FP}| > |I_{FN}|$ , referring to Table 1) will cause common-mode failure for transients which are fast enough.

Likewise for common-mode transients which occur when the LED is off (i.e.  $CM_H$ , since the output is “high”), if an imbalance between  $I_{LP}$  and  $I_{LN}$  results in a transient  $I_f$  equal to or greater than the switching threshold of the optocoupler, the transient “signal” may cause the output to spike below 2V (which constitutes a  $CM_H$  failure).

By using the recommended circuit in Figure 13, good CMR can be achieved. The resistors recommended in Figure 13 include both the output impedance of the logic driver circuit and the external limiting resistor. The balanced  $I_{LED}$ -setting resistors help equalize the common mode voltage change at anode and cathode to reduce the amount by which  $I_{LED}$  is modulated from transient coupling through  $C_{LA}$  and  $C_{LC}$ .

**Table 1. Effects of Common Mode Pulse Direction on Transient  $I_{LED}$**

If $dV_{CM}/dt$ Is:	then $I_{LP}$ Flows:	and $I_{LN}$ Flows:	If $ I_{LP}  <  I_{LN} $ , LED $I_f$ Current Is Momentarily:	If $ I_{LP}  >  I_{LN} $ , LED $I_f$ Current Is Momentarily:
positive (>0)	away from LED anode through $C_{LA}$	away from LED cathode through $C_{LC}$	increased	decreased
negative (<0)	toward LED anode through $C_{LA}$	toward LED cathode through $C_{LC}$	decreased	increased

## CMR with Other Drive Circuits

CMR performance with drive circuits other than that shown in Figure 13 may be enhanced by following these guidelines:

1. Use of drive circuits where current is shunted from the LED in the LED "off" state (as shown in Figures 15 and 16). This is beneficial for good  $CM_H$ .
  2. Use of typical  $I_{FH} = 6\text{mA}$  per datasheet recommendation
- Using any one of the drive circuits in Figures 15-17 with  $I_F = 6\text{mA}$  will result in a typical CMR of  $10\text{ kV}/\mu\text{s}$  for ACPL-M75L, as long as the PC board layout practices are followed. Figure 15 shows a circuit which can be used with

any totem-pole-output TTL/LSTTL/HCMOS logic gate. The buffer PNP transistor allows the circuit to be used with logic devices which have low current-sinking capability. It also helps maintain the driving-gate power-supply current at a constant level to minimize ground shifting for other devices connected to the input-supply ground.

When using an open-collector TTL or open-drain CMOS logic gate, the circuit in Figure 16 may be used. When using a CMOS gate to drive the optocoupler, the circuit shown in Figure 17, where the resistor is recommended to connect to the anode of the LED, may be used.

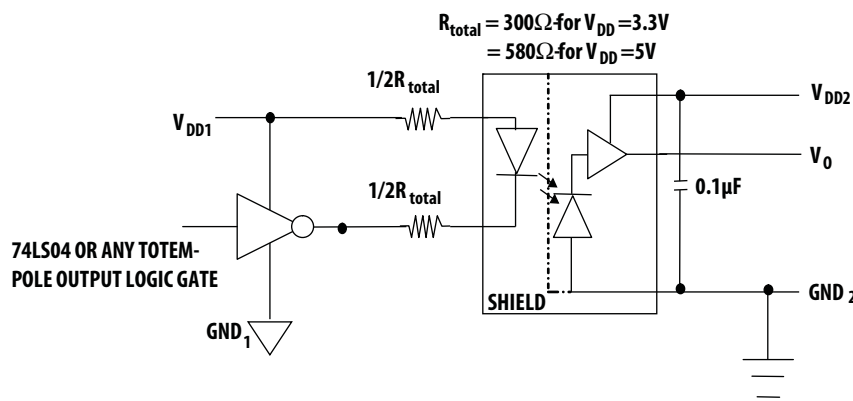

Figure 13. Recommended drive circuit for ACPL-M75L for high-CMR

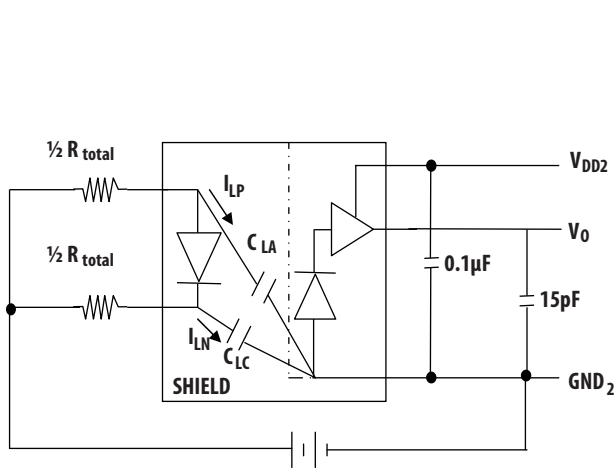

Figure 14. AC equivalent of ACPL-M75L

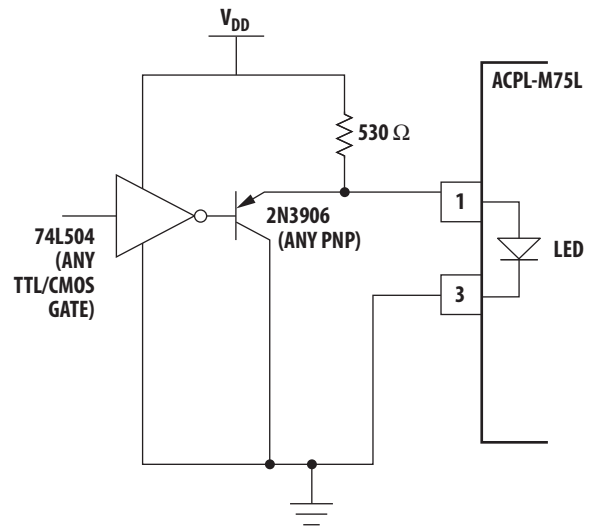

Figure 15. TTL interface circuit for the ACPL-M75L families.

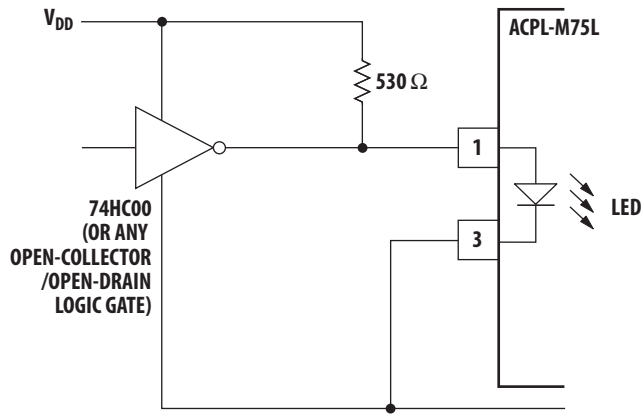

Figure 16. TTL open-collector/open drain gate drive circuit for ACPL-M75L families.

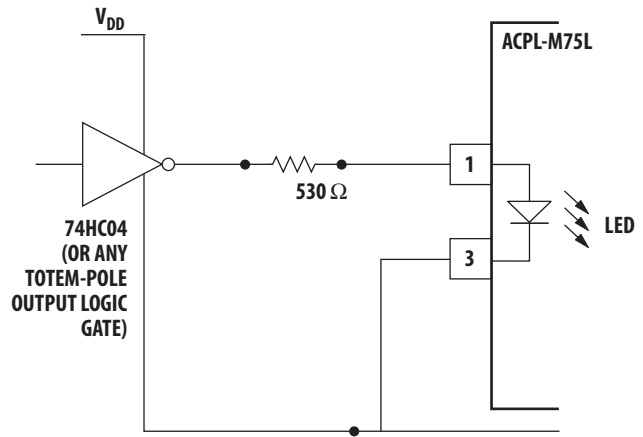

Figure 17. CMOS gate drive circuit for ACPL-M75L families.

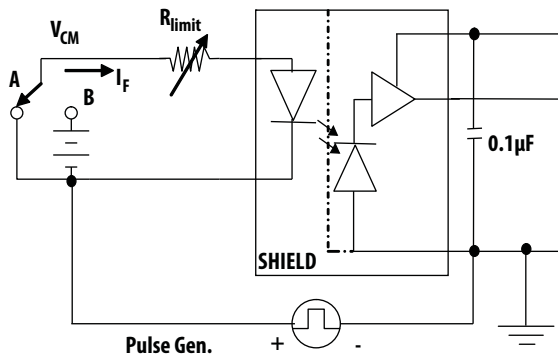
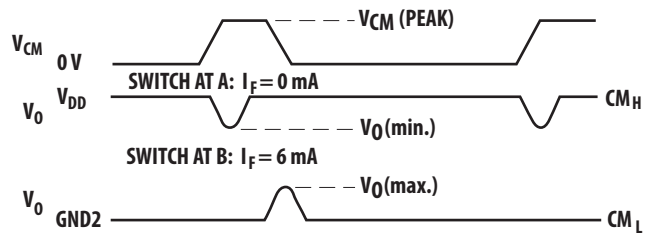

Figure 18. Test circuit for common mode transient immunity and typical waveforms.



For product information and a complete list of distributors, please go to our web site: [www.avagotech.com](http://www.avagotech.com)

Avago, Avago Technologies, and the A logo are trademarks of Avago Technologies in the United States and other countries. Data subject to change. Copyright © 2005-2012 Avago Technologies. All rights reserved. AV02-0963EN - August 15, 2012

**AVAGO**  
TECHNOLOGIES