

# XC164CM

## More Than a 16-bit Microcontroller



The XC164CM is a member of the enhanced 16-bit microcontroller family XC166 which offers impressive DSP performance and advanced interrupt handling combined with a powerful integrated peripheral set and high performance and reliable on-chip Flash memory.

The XC164CM is more than just a 16-bit microcontroller. The huge flexibility in combination with a small package makes it fit to any industrial and automotive applications that require little board space and low cost.

The XC166 family is the logic successor of Infineon's successful C166 family. The migration path from C166 to XC166 is supported by the same basic architecture and instruction set, so a high level of reuse can be achieved.

### Applications

- Automotive body & comfort
- Automotive safety
- Motor drive

### Features

- Single cycle 16-bit CPU with 5-stage pipeline
- 1-cycle multiplication (16 x 16 bit), background division (32/16 bit), 1-cycle multiply-and-accumulate (MAC) instructions
- Zero-cycle jump execution
- Register-based design with multiple variable register banks
- Fast context switch with two additional local register banks
- 16 Mbytes total linear address space for code and data
- 1024 Bytes on-chip SFR area (C166 family compatible)
- 16-priority-level interrupt system with up to 75 sources, sample rate down to 50 ns
- 8-channel interrupt-driven single-cycle data transfer facilities via peripheral event controller
- Clock generation via on-chip PLL or via prescaler

- 2 Kbytes on-chip dual-port RAM
- 2 Kbytes on-chip data SRAM
- 2 Kbytes on-chip program/data SRAM
- 64 Kbytes on-chip program memory (eFlash with ECC)
- 14-channel A/D converter with programmable resolution and conversion time down to 2.15  $\mu$ s
- One 16-channel general purpose capture/compare units
- Capture/compare unit for flexible PWM signal generation (3/6 capture/compare channels and 1 compare channel)
- Multi-functional general purpose timer unit with 5 timers
- Two synchronous/asynchronous serial channels (USARTs)
- Two high-speed synchronous serial channels
- On-chip TwinCAN interface (Rev. 2.0B active) with 32 MO and gateway functionality
- On-chip real time clock
- Enhanced power saving modes with flexible power management
- Programmable watchdog timer and oscillator watchdog
- Up to 47 general purpose I/O
- On-chip bootstrap loader
- Supported by a large range of development tools
- On-chip debug support via JTAG interface
- 64-pin PG-TQFP package, 0.5 mm (19.7 mil) pitch

[www.infineon.com/microcontrollers](http://www.infineon.com/microcontrollers)

## Microcontrollers



Never stop thinking.

## XC164CM Block Diagram

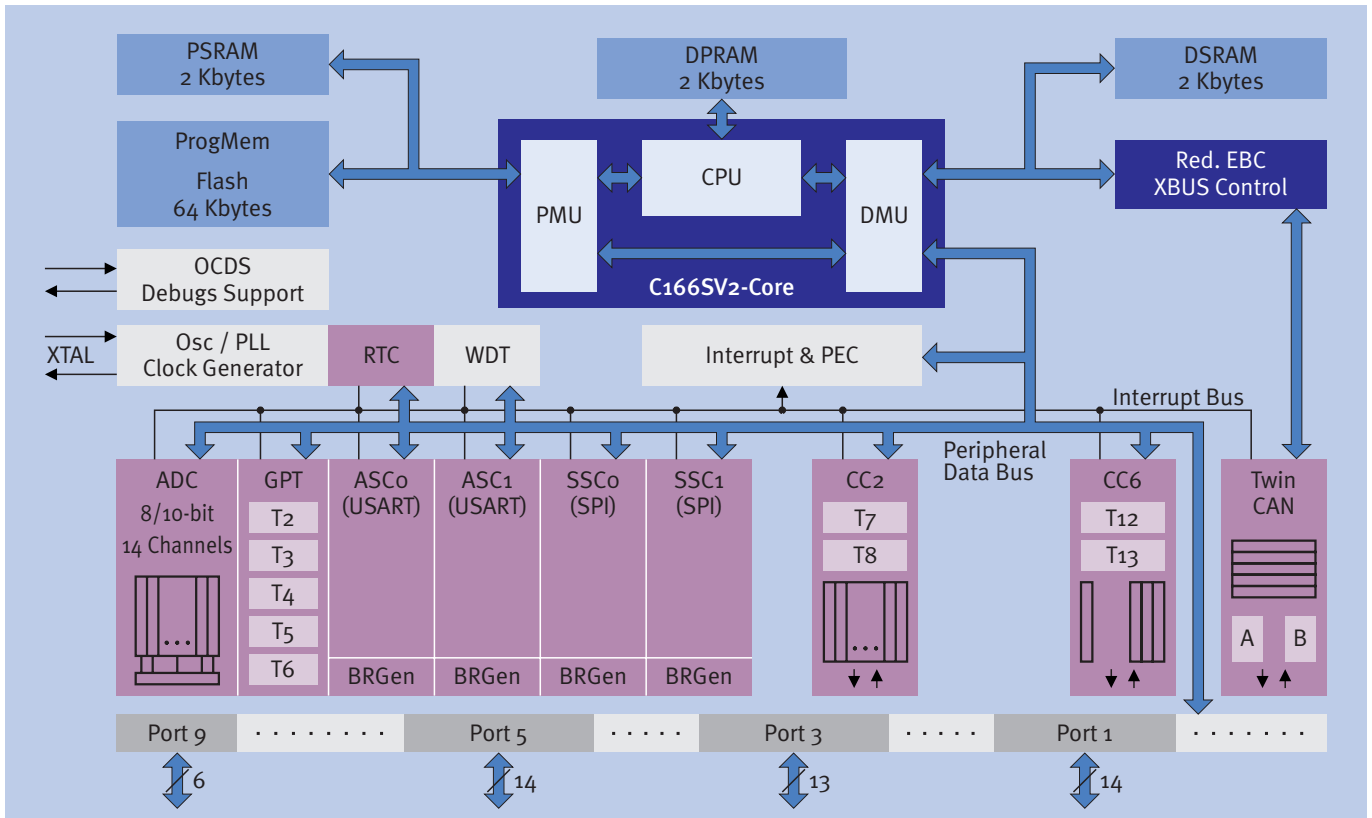

## Derivatives

Type	Sales Code	Package
SAF-XC164CM-8F2oF	Q67127-*	PG-TQFP-64
SAK-XC164CM-8F2oF	Q67127-*	PG-TQFP-64
SAF-XC164CM-8F4oF	Q67127-*	PG-TQFP-64
SAK-XC164CM-8F4oF	Q67127-*	PG-TQFP-64

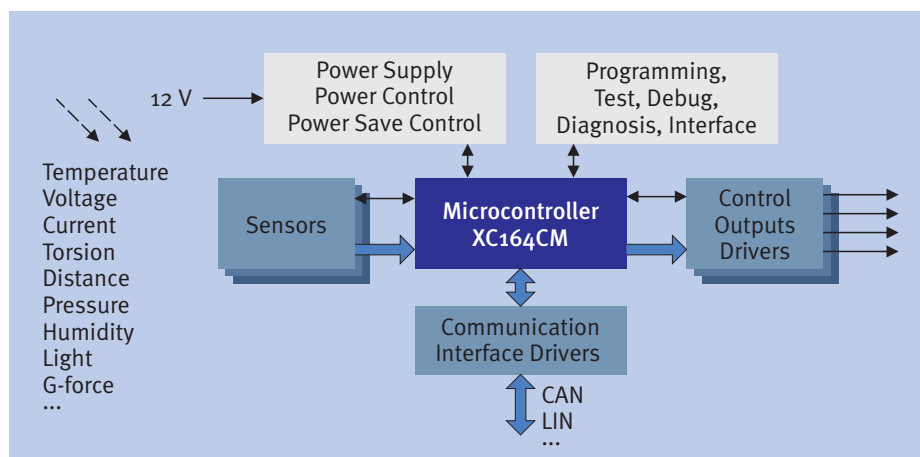

## Generic Application

How to reach us:  
<http://www.infineon.com>

Published by  
**Infineon Technologies AG,**  
 St.-Martin-Strasse 53,  
 D-81669 München

© Infineon Technologies AG 2004.  
 All Rights Reserved.

Template: pb\_tmplt.fm/4/2004-01-01

### Attention please!

The information herein is given to describe certain components and shall not be considered as a guarantee of characteristics. Terms of delivery and rights to technical change reserved.

We hereby disclaim any and all warranties, including but not limited to warranties of non-infringement, regarding circuits, descriptions and charts stated herein.

### Information

For further information on technology, delivery terms and conditions and prices please contact your nearest Infineon Technologies Office.

### Warnings

Due to technical requirements components may contain dangerous substances. For information on the types in question please contact your nearest Infineon Technologies Office.

Infineon Technologies Components may only be used in life-support devices or systems with the express written approval of Infineon Technologies, if a failure of such components can reasonably be expected to cause the failure of that life-support device or system, or to affect the safety or effectiveness of that device or system. Life support devices or systems are intended to be implanted in the human body, or to support and/or maintain and sustain and/or protect human life. If they fail, it is reasonable to assume that the health of the user or other persons may be endangered.

Ordering No. B158-H8386-X-X-7600  
 Printed in Germany  
 PS 02042. NB