

WCT1111DS

Features

- Compliant with the latest version Wireless Power Consortium (WPC) power class 0 specification power transmitter design
- Supports wide transmitter DC input voltage ranging from 4.2 V, typically 12 V and 19 V
- Integrated digital demodulation
- Supports two-way communication, transmitter to receiver by FSK and receiver to transmitter by ASK
- Supports all types of receiver modulation strategies (AC capacitor, AC resistor and DC resistor)
- Supports Q factor detection and calibrated power loss based Foreign Object Detection (FOD) framework
- Supports low standby power
- Supports various power control techniques: operation frequency control, duty cycle control, phase difference control and topology switch
- LED for system status indication
- Over-voltage/current/temperature protection
- Supports CAN/IIC/SCI/SPI interfaces
- Software-based solution to provide maximum design freedom and product differentiation
- FreeMASTER GUI tool to enable configuration, calibration and debugging

Applications

- Extended Power Profile Power Transmitter
Extended power profile consumer power transmitter solution with operation frequency and duty cycle control, phase difference control, and topology switch (WPC MP-Ax types, MP-Bx types or customer properties)

Overview Description

The WCT1111 is a wireless power transmitter controller that integrates all required functions for WPC “Qi” compliant wireless power transmitter design. It is an intelligent device that works with the NXP touch sensing technology or uses periodically analog PING to detect a mobile device for charging while gaining super low standby power. Once the mobile device is detected, the WCT1111 controls the power transfer by adjusting the operation frequency and duty cycle, or switching topology, or adjusting the phase difference of the power stage according to message packets sent by the mobile device.

To maximize the design freedom and product differentiation, the WCT1111 supports the extended power profile consumer power transmitter design (WPC MP-Ax types, MP-Bx types or customization) using operation frequency and duty cycle control, phase difference control and topology switch by software based solution, which can support wireless charging with both extended power profile power receiver and baseline power profile power receiver. In addition, the easy-to-use FreeMASTER GUI tool has configuration, calibration and debugging functions to provide the user-friendly design experience and reduce time-to-market.

The WCT1111 includes a digital demodulation module to reduce the external components, an FSK modulation module to support two-way communication, a protection module to handle the over-voltage/current/temperature protection, an FOD module to protect from overheating by misplaced metallic foreign objects, and general CAN/IIC/SCI/SPI interfaces for external communications. It also handles any abnormal condition and operational status and provides comprehensive indicator outputs for robust system design.

Wireless Charging System Functional Diagram

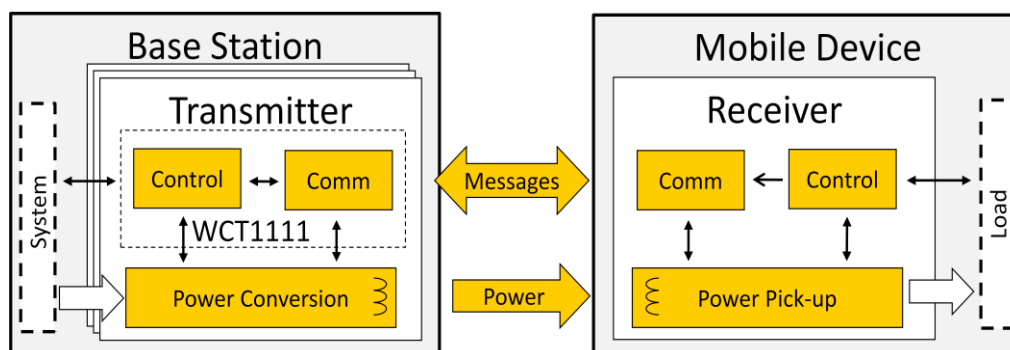

Contents

1	Absolute Maximum Ratings	4
1.1	Electrical operating ratings.....	4
1.2	Thermal handling ratings	5
1.3	ESD handling ratings	5
1.4	Moisture handling ratings	5
2	Electrical Characteristics	6
2.1	General characteristics.....	6
2.2	Device characteristics.....	8
2.3	Thermal operating characteristics	18
3	Typical Performance Characteristics	19
3.1	System efficiency	19
3.2	Standby power	19
3.3	Digital demodulation	19
3.4	Two-way communication.....	19
3.5	Foreign object detection	19
4	Device Information	20
4.1	Functional block diagram	20
4.2	Product features overview	20
4.3	Pinout diagram	22
4.4	Pin function description	22
4.5	Ordering information	32

4.6	Package outline drawing	32
5	Software Library	33
5.1	Memory map	33
5.2	Software library and API description.....	33
6	Design Considerations	34
6.1	Electrical design considerations	34
6.2	PCB layout considerations.....	35
6.3	Thermal design considerations.....	35
7	Links	37
8	Revision History.....	37

1 Absolute Maximum Ratings

1.1 Electrical operating ratings

Table 1. Absolute maximum electrical ratings ($V_{SS} = 0\text{ V}$, $V_{SSA} = 0\text{ V}$)

Characteristic	Symbol	Notes ¹	Min.	Max.	Unit
Supply Voltage Range	V_{DD}		-0.3	4.0	V
Analog Supply Voltage Range	V_{DDA}		-0.3	4.0	V
ADC High Voltage Reference	V_{REFHx}		-0.3	4.0	V
Voltage difference V_{DD} to V_{DDA}	ΔV_{DD}		-0.3	0.3	V
Voltage difference V_{SS} to V_{SSA}	ΔV_{SS}		-0.3	0.3	V
Digital Input Voltage Range	V_{IN}	Pin Group 1	-0.3	5.5	V
$\overline{\text{RESET}}$ Input Voltage Range	V_{IN_RESET}	Pin Group 2	-0.3	4.0	V
Oscillator Input Voltage Range	V_{OSC}	Pin Group 4	-0.4	4.0	V
Analog Input Voltage Range	V_{INA}	Pin Group 3	-0.3	4.0	V
Input clamp current, per pin ($V_{IN} < V_{SS} - 0.3\text{ V}$) ^{2,3}	V_{IC}		-	-5.0	mA
Output clamp current, per pin ⁴	V_{OC}		-	± 20.0	mA
Contiguous pin DC injection current—regional limit sum of 16 contiguous pins	I_{Icont}		-25	25	mA
Output Voltage Range (normal push-pull mode)	V_{OUT}	Pin Group 1,2	-0.3	4.0	V
Output Voltage Range (open drain mode)	V_{OUTOD}	Pin Group 1	-0.3	5.5	V
$\overline{\text{RESET}}$ Output Voltage Range	V_{OUTOD_RESET}	Pin Group 2	-0.3	4.0	V
DAC Output Voltage Range	V_{OUT_DAC}	Pin Group 5	-0.3	4.0	V
Ambient Temperature	T_A		-40	85	°C
Storage Temperature Range	T_{STG}		-55	150	°C

- Default Mode:
 - Pin Group 1: GPIO, TDI, TDO, TMS, TCK
 - Pin Group 2: $\overline{\text{RESET}}$
 - Pin Group 3: ADC and Comparator Analog Inputs
 - Pin Group 4: XTAL, EXTAL
 - Pin Group 5: DAC analog output
- Continuous clamp current.
- All 5 volt tolerant digital I/O pins are internally clamped to V_{SS} through an ESD protection diode. There is no diode connection to V_{DD} . If V_{IN} greater than V_{DIO_MIN} ($= V_{SS} - 0.3\text{ V}$) is observed, then there is no need to provide current limiting resistors at the pads. If this limit cannot be observed, then a current limiting resistor is required.
- I/O is configured as push-pull mode.

1.2 Thermal handling ratings

Table 2. Thermal handling ratings

Symbol	Description	Min.	Max.	Unit	Notes
T _{STG}	Storage temperature	-55	150	°C	1
T _{SDR}	Solder temperature, lead-free	-	260	°C	2

1. Determined according to JEDEC Standard JESD22-A103, *High Temperature Storage Life*.
2. Determined according to IPC/JEDEC Standard J-STD-020, *Moisture/Reflow Sensitivity Classification for Nonhermetic Solid State Surface Mount Devices*.

1.3 ESD handling ratings

Table 3. ESD handling ratings

Characteristic ¹	Min.	Max.	Unit
ESD for Human Body Model (HBM)	-2000	+2000	V
ESD for Machine Model (MM)	-200	+200	V
ESD for Charge Device Model (CDM)	-500	+500	V
Latch-up current at TA= 85°C (I _{LAT})	-100	+100	mA

1. Parameter is achieved by design characterization on a small sample size from typical devices under typical conditions unless otherwise noted.

1.4 Moisture handling ratings

Table 4. Moisture handling ratings

Symbol	Description	Min.	Max.	Unit	Notes
MSL	Moisture sensitivity level	-	3	-	1

1. Determined according to IPC/JEDEC Standard J-STD-020, *Moisture/Reflow Sensitivity Classification for Nonhermetic Solid State Surface Mount Devices*.

2 Electrical Characteristics

2.1 General characteristics

Table 5. General electrical characteristics

Recommended operating conditions ($V_{REFLX} = 0\text{ V}$, $V_{SSA} = 0\text{ V}$, $V_{SS} = 0\text{ V}$)							
Characteristic	Symbol	Notes	Min.	Typ.	Max.	Unit	Test conditions
Supply Voltage ²	V_{DD}, V_{DDA}		2.7	3.3	3.6	V	-
ADC (Cyclic) Reference Voltage High	V_{REFHA} V_{REFHB}		3.0		V_{DDA}	V	-
Voltage difference V_{DD} to V_{DDA}	ΔV_{DD}		-0.1	0	0.1	V	-
Voltage difference V_{SS} to V_{SSA}	ΔV_{SS}		-0.1	0	0.1	V	-
Input Voltage High (digital inputs)	V_{IH}	1 (Pin Group 1)	$0.7 \times V_{DD}$		5.5	V	-
$\overline{\text{RESET}}$ Voltage High	V_{IH_RESET}	1 (Pin Group 2)	$0.7 \times V_{DD}$	-	V_{DD}	V	-
Input Voltage Low (digital inputs)	V_{IL}	1 (Pin Group 1,2)			$0.35 \times V_{DD}$	V	-
Oscillator Input Voltage High XTAL driven by an external clock source	V_{IHOSC}	1 (Pin Group 4)	2.0		$V_{DD} + 0.3$	V	-
Oscillator Input Voltage Low	V_{ILOSC}	1 (Pin Group 4)	-0.3		0.8	V	-
Output Source Current High (at V_{OH} min.) ^{3,4} • Programmed for low drive strength • Programmed for high drive strength	I_{OH}	1 (Pin Group 1) 1 (Pin Group 1)	- -		-2 -9	mA	-
Output Source Current Low (at V_{OL} max.) ^{3,4} • Programmed for low drive strength • Programmed for high drive strength	I_{OL}	1 (Pin Group 1,2) 1 (Pin Group 1,2)	- -		2 9	mA	-
Output Voltage High	V_{OH}	1 (Pin Group 1)	$V_{DD} - 0.5$	-	-	V	$I_{OH} = I_{OHmax}$
Output Voltage Low	V_{OL}	1 (Pin Group 1,2)	-	-	0.5	V	$I_{OL} = I_{OLmax}$

Digital Input Current High pull-up enabled or disabled	I _{IH}	1 (Pin Group 1)	-	0	+/-2.5	μA	V _{IN} = 2.4 V to 5.5 V
		1 (Pin Group 2)					V _{IN} = 2.4 V to V _{DD}
Comparator Input Current High	I _{IHC}	1 (Pin Group 3)		0	+/-2	μA	V _{IN} = V _{DDA}
Oscillator Input Current High	I _{IHOSC}	1 (Pin Group 4)	-	0	+/-2	μA	V _{IN} = V _{DDA}
Internal Pull-Up Resistance	R _{Pull-Up}		20	-	50	kΩ	-
Internal Pull-Down Resistance	R _{Pull-Down}		20	-	50	kΩ	-
Comparator Input Current Low	I _{IILC}	1 (Pin Group 3)	-	0	+/-2	μA	V _{IN} = 0V
Oscillator Input Current Low	I _{ILOSC}	1 (Pin Group 4)	-	0	+/-2	μA	V _{IN} = 0V
DAC Output Voltage Range	V _{DAC}	1 (Pin Group 5)	V _{SSA} + 0.04	-	V _{DDA} - 0.04	V	R _{LD} = 3 kΩ, C _{LD} = 400 pF
Output Current ¹ High Impedance State	I _{oZ}	1 (Pin Group 1,2)	-	0	+/-1	μA	-
Schmitt Trigger Input Hysteresis	V _{HYS}	1 (Pin Group 1,2)	0.06×V _{DD}	-	-	V	-
Input capacitance	C _{IN}		-	10	-	pF	-
Output capacitance	C _{OUT}		-	10	-	pF	-
GPIO pin interrupt pulse width ⁵	T _{INT_Pulse}	6	1.5	-	-	Bus clock	-
Port rise and fall time (high drive strength). Slew disabled.	T _{Port_H_DIS}	7	5.5	-	15.1	ns	2.7 ≤ V _{DD} ≤ 3.6 V
Port rise and fall time (high drive strength). Slew enabled.	T _{Port_H_EN}	7	1.5	-	6.8	ns	2.7 ≤ V _{DD} ≤ 3.6 V
Port rise and fall time (low drive strength). Slew disabled.	T _{Port_L_DIS}	8	8.2	-	17.8	ns	2.7 ≤ V _{DD} ≤ 3.6 V
Port rise and fall time (low drive strength). Slew enabled.	T _{Port_L_EN}	8	3.2	-	9.2	ns	2.7 ≤ V _{DD} ≤ 3.6 V
Device (system and core) clock frequency	f _{SYSClk}		0	-	100	MHz	-
Bus clock	f _{BUS}		-	-	50	MHz	-

1. Default Mode

- Pin Group 1: GPIO, TDI, TDO, TMS, TCK
- Pin Group 2: $\overline{\text{RESET}}$
- Pin Group 3: ADC and Comparator Analog Inputs

- Pin Group 4: XTAL, EXTAL
 - Pin Group 5: DAC analog output
2. ADC (Cyclic) specifications are not guaranteed when VDDA is below 3.0 V.
 3. Total chip source or sink current cannot exceed 75 mA.
 4. Contiguous pin DC injection current of regional limit—including sum of negative injection currents or sum of positive injection currents of 16 contiguous pins—is 25 mA.
 5. Applies to a pin only when it is configured as GPIO and configured to cause an interrupt by appropriately programming GPIO_n_IPOLR and GPIO_n_IENR.
 6. The greater synchronous and asynchronous timing must be met.
 7. 75 pF load.
 8. 15 pF load.

2.2 Device characteristics

Table 6. General device characteristics

Power mode transition behavior					
Symbol	Description	Min.	Max.	Unit	Notes
T _{POR}	After a POR event, the amount of delay from when VDD reaches 2.7 V to when the first instruction executes (over the operating temperature range).	199	225	μs	
T _{S2R}	STOP mode to RUN mode	6.79	7.27	μs	1
T _{LPS2LPR}	LPS mode to LPRUN mode	240.9	551	μs	2
T _{VLPS2VLPR}	VLPS mode to VLPRUN mode	1424	1459	μs	4
T _{W2R}	WAIT mode to RUN mode	0.57	0.62	μs	3
T _{LPW2LPR}	LPWAIT mode to LPRUN mode	237.2	554	μs	2
T _{VLPW2VLPR}	VLPWAIT mode to VLPRUN mode	1413	1500	μs	4
Power consumption operating behaviors					
Mode	Conditions	Max. frequency	Typical at 3.3 V, 25 °C		Notes
			I _{DD}	I _{DDA}	

RUN1	100 MHz core clock, 50 MHz peripheral clock, regulators are in full regulation, relaxation oscillator on, PLL powered on, continuous MAC instructions with fetches from program Flash, all peripheral modules enabled, TMRs and SCIs using 1× peripheral clock, NanoEdge within eFlexPWM using 2× peripheral clock, ADC/DAC (only one 12-bit DAC and all 6-bit DACs) powered on and clocked, comparator powered on, all ports configured as inputs with input low and no DC loads	100 MHz	38.1 mA	9.9 mA	
RUN2	50 MHz core and peripheral clock, regulators are in full regulation, relaxation oscillator on, PLL powered on, continuous MAC instructions with fetches from program Flash, all peripheral modules enabled, TMRs and SCIs using 1× peripheral clock, NanoEdge within eFlexPWM using 2× peripheral clock, ADC/DAC (only one 12-bit DAC and all 6-bit DACs) powered on and clocked, comparator powered on, all ports configured as inputs with input low and no DC loads	50 MHz	27.6 mA	9.9 mA	
WAIT	50 MHz core and peripheral clock, regulators are in full regulation, relaxation oscillator on, PLL powered on, core in WAIT state, all peripheral modules enabled, TMRs and SCIs using 1× clock, NanoEdge within eFlexPWM using 2× clock, ADC/DAC (one 12-bit DAC, all 6-bit DACs)/comparator powered off, all ports configured as inputs with input low and no DC loads	50 MHz	24.0 mA	-	
STOP	4 MHz core and peripheral clock, regulators are in full regulation, relaxation oscillator on, PLL powered off, core in STOP state, all peripheral module and core clocks are off, ADC/DAC/Comparator powered off, all ports configured as inputs with input low and no DC loads	4 MHz	6.3 mA	-	

LPRUN	200 kHz core and peripheral clock from relaxation oscillator's low-speed clock, relaxation oscillator in standby mode, regulators are in standby, PLL disabled, repeat NOP instructions, all peripheral modules enabled, except NanoEdge within eFlexPWM and cyclic ADCs, one 12-bit DAC and all 6-bit DACs enabled, simple loop with running from platform instruction buffer, all ports configured as inputs with input low and no DC loads	2 MHz	2.8 mA	3.1 mA	
LPWAIT	200 kHz core and peripheral clock from relaxation oscillator's low-speed clock, relaxation oscillator in standby mode, regulators are in standby, PLL disabled, all peripheral modules enabled, except NanoEdge within eFlexPWM and cyclic ADCs, one 12-bit DAC and all 6-bit DACs enabled, core in WAIT mode, all ports configured as inputs with input low and no DC loads	2 MHz	2.7 mA	3.1 mA	
LPSTOP	200 kHz core and peripheral clock from relaxation oscillator's low-speed clock, relaxation oscillator in standby mode, regulators are in standby, PLL disabled, only PITs and COP enabled, other peripheral modules disabled and clocks gated off, core in STOP mode, all ports configured as inputs with input low and no DC loads	2 MHz	1.2 mA	-	
VLPRUN	32 kHz core and peripheral clock from a 64 kHz external clock source, oscillator in power down, all relaxation oscillators disabled, large regulator is in standby, small regulator is disabled, PLL disabled, repeat NOP instructions, all peripheral modules, except COP and EWM, disabled and clocks gated off, simple loop running from platform instruction buffer, all ports configured as inputs with input low and no DC loads	200 kHz	0.7 mA	-	
VLPWAIT	32 kHz core and peripheral clock from a 64 kHz external clock source, oscillator in power down, all relaxation oscillators disabled, large regulator is in standby, small regulator is disabled, PLL disabled, all peripheral modules, except COP, disabled and clocks gated off, core in WAIT mode, all ports configured as inputs with input low and no DC loads	200 kHz	0.7 mA	-	

VLPSTOP	32 kHz core and peripheral clock from a 64 kHz external clock source, oscillator in power down, all relaxation oscillators disabled, large regulator is in standby, small regulator is disabled, PLL disabled, all peripheral modules, except COP, disabled and clocks gated off, core in STOP mode, all ports configured as inputs with input low and no DC loads	200 kHz	0.7 mA	-	
Reset and interrupt timing					
Symbol	Characteristic	Min.	Max.	Unit	Notes
t_{RA}	Minimum \overline{RESET} Assertion Duration	16	-	ns	5
t_{RDA}	\overline{RESET} desertion to First Address Fetch	$865 \times T_{OSC} + 8 \times T_{SYSCLK}$	-	ns	6
t_{IF}	Delay from Interrupt Assertion to Fetch of first instruction (exiting STOP mode)	361.3	570.9	ns	
PMC Low-Voltage Detection (LVD) and Power-On Reset (POR) parameters					
Symbol	Characteristic	Min.	Typ.	Max.	Unit
V_{POR_A}	POR Assert Voltage ⁷	-	2.0	-	V
V_{POR_R}	POR Release Voltage ⁸	-	2.7	-	V
V_{LVI_2p7}	LVI_2p7 Threshold Voltage	-	2.73	-	V
V_{LVI_2p2}	LVI_2p2 Threshold Voltage	-	2.23	-	V
JTAG timing					
Symbol	Description	Min.	Max.	Unit	Notes
f_{OP}	TCK frequency of operation	DC	$f_{SYSCLK}/8$	MHz	
t_{PW}	TCK clock pulse width	50	-	ns	
t_{DS}	TMS, TDI data set-up time	5	-	ns	
t_{DH}	TMS, TDI data hold time	5	-	ns	
t_{DV}	TCK low to TDO data valid	-	30	ns	
t_{TS}	TCK low to TDO tri-state	-	30	ns	
Regulator 1.2 V parameters					
Symbol	Characteristic	Min.	Typ.	Max.	Unit
V_{CAP}	Output Voltage ⁹	-	1.22	-	V
I_{SS}	Short Circuit Current ¹⁰	-	600	-	mA
T_{RSC}	Short Circuit Tolerance (V_{CAP} shorted to ground)	-	-	30	Mins

V _{REF}	Reference Voltage (after trim)	-	1.21	-	V
External clock timing					
Symbol	Characteristic	Min.	Typ.	Max.	Unit
f _{OSC}	Frequency of operation (external clock driver)	-	-	50	MHz
t _{PW}	Clock pulse width ¹¹	8			ns
t _{rise}	External clock input rise time ¹²	-	-	1	ns
t _{fall}	External clock input fall time ¹³	-	-	1	ns
V _{ih}	Input high voltage overdrive by an external clock	0.85×V _{DD}	-	-	V
V _{il}	Input low voltage overdrive by an external clock	-	-	0.3×V _{DD}	V
Phase-Locked Loop (PLL) timing					
Symbol	Characteristic	Min.	Typ.	Max.	Unit
f _{Ref_PLL}	PLL input reference frequency ¹⁴	8	8	16	MHz
f _{OP_PLL}	PLL output frequency ¹⁵	200	-	400	MHz
t _{Lock_PLL}	PLL lock time ¹⁶	35.5	-	73.2	μs
t _{DC_PLL}	Allowed Duty Cycle of input reference	40	50	60	%
External crystal or resonator specifications					
Symbol	Characteristic	Min.	Typ.	Max.	Unit
f _{XOSC}	Frequency of operation	4	8	16	MHz
Relaxation oscillator electrical specifications					
Symbol	Characteristic	Min.	Typ.	Max.	Unit
f _{ROSC_8M}	8 MHz Output Frequency ¹⁷ RUN Mode • 0 °C to 85 °C	7.84	8	8.16	MHz
	• -40 °C to 85 °C	7.76	8	8.24	MHz
	Standby Mode (IRC trimmed @ 8 MHz) • -40 °C to 85 °C	-	405	-	kHz
f _{ROSC_8M_Delta}	8 MHz Frequency Variation over 25 °C RUN Mode Due to temperature • 0 °C to 85 °C	-	+/-1.5	+/-2	%
	• -40 °C to 85 °C	-	+/-1.5	+/-3	%
f _{ROSC_200k} ¹⁷	200 kHz Output Frequency ¹⁸ RUN Mode • -40 °C to 85 °C	194	200	206	kHz

$f_{ROSC_200k_Delta}$ ¹⁷	200 kHz Output Frequency Variation over 25 °C ¹⁸ RUN Mode Due to temperature • 0 °C to 85 °C • -40 °C to 85 °C	- -	+/-1.5 +/-1.5	+/-2 +/-3	% %
t_{Stab}	Stabilization Time • 8 MHz output ¹⁹ • 200 kHz output ²⁰	- -	0.12 10	- -	µs µs
t_{DC_ROSC}	Output Duty Cycle	48	50	52	%

Flash specifications

Symbol	Description	Min.	Typ.	Max.	Unit
t_{hvp4}	Longword Program high-voltage time	-	7.5	18	µs
$t_{hversscr}$	Sector Erase high-voltage time ²¹	-	13	113	ms
$t_{hversall}$	Erase All high-voltage time ²¹	-	52	452	ms
$t_{rd1sec1k}$	Read 1s Section execution time (flash sector) ²²	-	-	60	µs
t_{pgmchk}	Program Check execution time ²²	-	-	45	µs
t_{rdsrc}	Read Resource execution time ²²	-	-	30	µs
t_{pgm4}	Program Longword execution time	-	65	145	µs
t_{ersscr}	Erase Flash Sector execution time ²³	-	14	114	ms
t_{rd1all}	Read 1s All Blocks execution time	-	-	0.9	ms
t_{rdonce}	Read Once execution time ²²	-	-	25	µs
$t_{pgmonce}$	Program Once execution time	-	65	-	µs
t_{ersall}	Erase All Blocks execution time ²³	-	70	575	ms
t_{vtykey}	Verify Backdoor Access Key execution time ²²	-	-	30	µs
$t_{flashret10k}$	Data retention after up to 10 K cycles	5	50 ²⁴	-	years
$t_{flashret1k}$	Data retention after up to 1 K cycles	20	100 ²⁴	-	years
$n_{flashcyc}$	Cycling endurance ²⁵	10 K	50 K ²⁴	-	cycles

12-bit cyclic ADC electrical specifications

Symbol	Characteristic	Min.	Typ.	Max.	Unit
V_{DDA}	Supply voltage ²⁶	3.0	3.3	3.6	V
V_{REFHX}	V_{REFH} supply voltage ²⁷	$V_{DDA} - 0.6$		V_{DDA}	V
f_{ADCCLK}	ADC conversion clock ²⁸	0.1	-	10	MHz
R_{ADC}	Conversion range ²⁹ • Fully differential • Single-ended/unipolar	$-(V_{REFH} - V_{REFL})$ V_{REFL}	- -	$V_{REFH} - V_{REFL}$ V_{REFH}	V V

V_{ADCIN}	Input voltage range (per input) ³⁰ <ul style="list-style-type: none"> External Reference Internal Reference 	V_{REFL} V_{SSA}	- -	V_{REFH} V_{DDA}	V V
t_{ADC}	Conversion time	-	8	-	t_{ADCCLK}
t_{ADCPU}	ADC power-up time (from adc_pdn)	-	13	-	t_{ADCCLK}
I_{ADCRUN}	ADC RUN current (per ADC block)	-	1.8	-	mA
I_{ADPWRDWN}	ADC power down current (adc_pdn enabled)	-	0.1	-	μA
I_{VREFH}	V_{REFH} current (in external mode)	-	190	225	μA
INL_{ADC}	Integral non-linearity ³¹	-	+/- 1.5	+/- 2.2	LSB ³²
DNL_{ADC}	Differential non-linearity ³¹	-	+/- 0.5	+/- 0.8	LSB ³²
V_{OFFSET}	Offset ³³ <ul style="list-style-type: none"> Fully differential Single ended/Unipolar 	- -	+/- 8 +/- 12	- -	mV mV
E_{GAIN}	Gain Error	-	0.996 to 1.004	0.99 to 1.101	-
ENOB	Effective number of bits	-	10.6	-	bits
I_{INJ}	Input injection current ³⁴	-	-	+/-3	mA
C_{ADCI}	Input sampling capacitance	-	4.8	-	pF

12-bit DAC electrical specifications

Symbol	Characteristic	Min.	Typ.	Max.	Unit
t_{SETTLE}	Settling time ³⁵ under $R_{\text{LD}} = 3 \text{ k}\Omega$, $C_{\text{LD}} = 400 \text{ pF}$	-	1	-	μs
t_{DACPU}	DAC power-up time (from PWRDWN release to valid DACOUT)	-	-	11	μs
INL_{DAC}	Integral non-linearity ³⁷	-	+/- 3	+/- 4	LSB ³⁶
DNL_{DAC}	Differential non-linearity ³⁷	-	+/- 0.8	+/- 0.9	LSB ³⁶
MON_{DAC}	Monotonicity (> 6 sigma monotonicity, < 3.4 ppm non-monotonicity)	Guaranteed			-
V_{OFFSET}	Offset error ³⁷ (5% to 95% of full range)	-	+/- 25	+/- 43	mV
E_{GAIN}	Gain error ³⁷ (5% to 95% of full range)	-	+/- 0.5	+/- 1.5	%
V_{OUT}	Output voltage range	$V_{\text{SSA}} + 0.04$	-	$V_{\text{DDA}} - 0.04$	V
SNR	Signal-to-noise ratio	-	85	-	dB
ENOB	Effective number of bits	-	11	-	bits

Comparator and 6-bit DAC electrical specifications

Symbol	Description	Min.	Typ.	Max.	Unit
V_{DD}	Supply voltage	2.7	-	3.6	V

I _{DDHS}	Supply current, High-speed mode(EN=1, PMODE=1)	-	300	-	μA
I _{DDL}	Supply current, Low-speed mode(EN=1, PMODE=0)	-	36	-	μA
V _{AIN}	Analog input voltage	V _{SS}	-	V _{DD}	V
V _{AIO}	Analog input offset voltage	-	-	20	mV
V _H	Analog comparator hysteresis ³⁸ <ul style="list-style-type: none"> • CR0[HYSTCTR]=00 • CR0[HYSTCTR]=01 • CR0[HYSTCTR]=10 • CR0[HYSTCTR]=11 	-	5	13	mV
		-	25	48	mV
		-	55	105	mV
		-	80	148	mV
V _{CMPOh}	Output high	V _{DD} - 0.5	-	-	V
V _{CMPOl}	Output low	-	-	0.5	V
t _{DHS}	Propagation delay, high-speed mode(EN=1, PMODE=1) ³⁹	-	25	50	ns
t _{DLS}	Propagation delay, low-speed mode(EN=1, PMODE=0) ³⁹	-	60	200	ns
t _{DInit}	Analog comparator initialization delay ⁴⁰	-	40	-	μs
I _{DAC6b}	6-bit DAC current adder (enabled)	-	7	-	μA
R _{DAC6b}	6-bit DAC reference inputs	V _{DDA}	-	V _{DD}	V
INL _{DAC6b}	6-bit DAC integral non-linearity	-0.5	-	0.5	LSB ⁴¹
DNL _{DAC6b}	6-bit DAC differential non-linearity	-0.3	-	0.3	LSB ⁴¹
eFlexPWM timing parameters					
Symbol	Characteristic	Min.	Typ.	Max.	Unit
f _{PWM}	PWM clock frequency	-	100	-	MHz
S _{PWMNEP}	NanoEdge Placement (NEP) step size ^{42,43}	-	312	-	ps
t _{DFLT}	Delay for fault input activating to PWM output deactivated	1	-	-	ns
t _{PWMPU}	Power-up time ⁴⁴	-	25	-	μs
Quad timer timing					
Symbol	Characteristic	Min.	Max.	Unit	Notes
P _{IN}	Timer input period	2T _{timer} + 6	-	ns	45
P _{INHL}	Timer input high/low period	1T _{timer} + 3	-	ns	45
P _{OUT}	Timer output period	2T _{timer} - 2	-	ns	45
P _{OUTH}	Timer output high/low period	1T _{timer} - 2	-	ns	45

QSPI timing							
Symbol	Characteristic	Min.		Max.		Unit	
		Master	Slave	Master	Slave		
t _C	Cycle time	60	60	-	-	ns	
t _{ELD}	Enable lead time	-	20	-	-	ns	
t _{ELG}	Enable lag time	-	20	-	-	ns	
t _{CH}	Clock (SCLK) high time	28	28	-	-	ns	
t _{CL}	Clock (SCLK) low time	28	28	-	-	ns	
t _{DS}	Data set-up time required for inputs	20	1	-	-	ns	
t _{DH}	Data hold time required for inputs	1	3	-	-	ns	
t _A	Access time (time to data active from high-impedance state)		5		-	ns	
t _D	Disable time (hold time to high-impedance state)		5		-	ns	
t _{DV}	Data valid for outputs	-	-			ns	
t _{DI}	Data invalid	0	0	-	-	ns	
t _R	Rise time	-	-	1	1	ns	
t _F	Fall time	-	-	1	1	ns	
QSCI timing							
Symbol	Characteristic	Min.	Max.	Unit	Notes		
BR _{SCI}	Baud rate	-	(f _{MAX_SCI} / 16)	Mbit/s	46		
PW _{RXD}	RXD pulse width	0.965/BR _{SCI}	1.04/BR _{SCI}	μs			
PW _{TXD}	TXD pulse width	0.965/BR _{SCI}	1.04/BR _{SCI}	μs			
CAN timing							
Symbol	Characteristic	Min.	Max.	Unit	Notes		
BR _{CAN}	Baud rate	-	1	Mbit/s			
T _{WAKEUP}	CAN Wakeup dominant pulse filtered	-	1.5	μs			
T _{WAKEUP}	CAN Wakeup dominant pulse pass	5	-	μs			
IIC timing							
Symbol	Characteristic	Min.		Max.		Unit	Notes
		Min.	Max.	Min.	Max.		
f _{SCL}	SCL clock frequency	0	100	0	400	kHz	
t _{HD_STA}	Hold time (repeated) START condition. After this period, the first clock pulse is generated.	4	-	0.6	-	μs	
t _{SCL_LOW}	LOW period of the SCL clock	4.7	-	1.3	-	μs	
t _{SCL_HIGH}	HIGH period of the SCL clock	4	-	0.6	-	μs	

t _{SU_STA}	Set-up time for a repeated START condition	4.7	-	0.6	-	μs	
t _{HD_DAT}	Data hold time for IIC bus devices	0 ⁴⁷	3.45 ⁴⁸	0 ⁴⁹	0.9 ⁴⁷	μs	
t _{SU_DAT}	Data set-up time	250 ⁵⁰	-	100 ⁵¹	-	ns	48
t _r	Rise time of SDA and SCL signals	-	1000	20 + 0.1C _b	300	ns	52
t _f	Fall time of SDA and SCL signals	-	300	20 + 0.1C _b	300	ns	51
t _{SU_STOP}	Set-up time for STOP condition	4	-	0.6	-	μs	
t _{BUS_Free}	Bus free time between STOP and START condition	4.7	-	1.3	-	μs	
t _{SP}	Pulse width of spikes that must be suppressed by the input filter	N/A	N/A	0	50	ns	

- CPU clock = 4 MHz and System running from 8 MHz IRC Applicable to all wakeup times: Wakeup times (in 1,2,3,4) are measured from GPIO toggle for wakeup till GPIO toggle at the wakeup interrupt subroutine from respective stop/wait mode.
- CPU clock = 200 kHz and 8 MHz IRC on standby. Exit via interrupt on Port C GPIO.
- Clock configuration: CPU and system clocks= 100 MHz; Bus Clock = 50 MHz. Exit via an interrupt on PortC GPIO.
- Using 64 KHz external clock; CPU Clock = 32 KHz. Exit via an interrupt on PortC GPIO.
- If the RESET pin filter is enabled by setting the RST_FLT bit in the SIM_CTRL register to 1, the minimum pulse assertion must be greater than 21 ns.
- TOSC means oscillator clock cycle; TSYCLK means system clock cycle.
- During 3.3 V VDD power supply ramp down.
- During 3.3 V VDD power supply ramp up (gated by LVI_2p7).
- Value is after trim.
- Guaranteed by design.
- The chip may not function if the high or low pulse width is smaller than 6.25 ns.
- External clock input rise time is measured from 10% to 90%.
- External clock input fall time is measured from 90% to 10%.
- An externally supplied reference clock should be as free as possible from any phase jitter for the PLL to work correctly. The PLL is optimized for 8 MHz input.
- The frequency of the core system clock cannot exceed 100 MHz. If the NanoEdge PWM is available, the PLL output must be set to 400 MHz.
- This is the time required after the PLL is enabled to ensure reliable operation.
- Frequency after application of 8 MHz trimmed.
- Frequency after application of 200 kHz trimmed.
- Standby to run mode transition.
- Power down to run mode transition.
- Maximum time based on expectations at cycling end-of-life.
- Assumes 25 MHz flash clock frequency.
- Maximum times for erase parameters based on expectations at cycling end-of-life.
- Typical data retention values are based on measured response accelerated at high temperature and derated to a constant 25°C use profile. Engineering Bulletin EB618 does not apply to this technology. Typical endurance defined in Engineering Bulletin EB619.
- Cycling endurance represents number of program/erase cycles at -40°C ≤ T_j ≤ 125°C.
- The ADC functions up to VDDA = 2.7 V. When VDDA is below 3.0 V, ADC specifications are not guaranteed.
- When the input is at the V_{REFL} level, the resulting output is all zeros (hex 000), plus any error contribution due to offset and gain error. When the input is at the V_{REFH} level the output is all ones (hex FFF), minus any error contribution due to offset and gain error.
- ADC clock duty cycle is 45% ~ 55%.
- Conversion range is defined for x1 gain setting. For x2 and x4 the range is 1/2 and 1/4, respectively.
- In unipolar mode, positive input must be ensured to be always greater than negative input.
- INL_{ADC}/DNL_{ADC} is measured from VADCIN = VREFL to VADCIN = VREFH using Histogram method at x1 gain setting.
- Least Significant Bit = 0.806 mV at 3.3 V VDDA, x1 gain setting.
- Any off-channel with 50 kHz full-scale input to the channel being sampled with DC input (isolation crosstalk).
- The current that can be injected into or sourced from an unselected ADC input without affecting the performance of the ADC.
- Settling time is swing range from VSSA to VDDA.

36. LSB = 0.806 mV.
37. No guaranteed specification within 5% of VDDA or VSSA.
38. Typical hysteresis is measured with input voltage range limited to 0.7 to VDD-0.7 V.
39. Signal swing is 100 mV.
40. Comparator initialization delay is defined as the time between software writes to change control inputs (Writes to DACEN, VRSEL, PSEL, MSEL, VOSEL) and the comparator output settling to a stable level.
41. $1 \text{ LSB} = V_{\text{reference}}/64$.
42. Reference IPbus clock of 100 MHz in NanoEdge Placement mode.
43. Temperature and voltage variations do not affect NanoEdge Placement step size.
44. Powerdown to NanoEdge mode transition.
45. $T_{\text{timer}} = \text{Timer input clock cycle}$. For 100 MHz operation, $T_{\text{timer}} = 10 \text{ ns}$.
46. $f_{\text{MAX_SCI}}$ is the frequency of operation of the SCI clock in MHz, which can be selected as the bus clock or 2x bus clock for the device.
47. The master mode IIC deasserts ACK of an address byte simultaneously with the falling edge of SCL. If no slaves acknowledge this address byte, then a negative hold time can result, depending on the edge rates of the SDA and SCL lines.
48. The maximum $t_{\text{HD_DAT}}$ must be met only if the device does not stretch the LOW period ($t_{\text{SCL_LOW}}$) of the SCL signal.
49. Input signal Slew = 10 ns and Output Load = 50 pF
50. Set-up time in slave-transmitter mode is 1 IPBus clock period, if the TX FIFO is empty.
51. A Fast mode IIC bus device can be used in a Standard mode IIC bus system, but the requirement $t_{\text{SU_DAT}} \geq 250 \text{ ns}$ must then be met. This occurs when the device does not stretch the LOW period of the SCL signal. If such a device does stretch the LOW period of the SCL signal, then it must output the next data bit to the SDA line $t_{\text{rmax}} + t_{\text{SU_DAT}} = 1000 + 250 = 1250 \text{ ns}$ (according to the Standard mode IIC bus specification) before the SCL line is released.
52. C_b = total capacitance of the one bus line in pF.

2.3 Thermal operating characteristics

Table 7. General thermal characteristics

Symbol	Description	Min.	Max.	Unit
T_J	Die junction temperature	-40	125	°C
T_A	Ambient temperature	-40	85	°C

3 Typical Performance Characteristics

3.1 System efficiency

The maximum system efficiency (receiver output power vs. transmitter input power) on NXP WCT1111-based transmitter solutions can usually reach more than 75%. The detailed number depends on the specific solution type. For example, NXP WCT-15W1COILTX reference solution has more than 75% system efficiency with the MP Qi Receiver Simulator.

Note: Power components are the main factor to determine the system efficiency, such as drivers and MOSFETs.

3.2 Standby power

The purpose of the standby mode of operation is to reduce the power consumption of a wireless power transfer system when power transfer is not required. There are two ways to enter standby mode. The first is when the transmitter does not detect the presence of a valid receiver. The second is when the receiver sends only an End Power Transfer Packet. In standby mode, the transmitter only monitors if a receiver is placed on the active charging area of the transmitter or removed from there.

It is recommended that the power consumption of the transmitter in standby mode meets the relative regional regulations especially for “No-load power consumption”.

In NXP WCT-15W1COILTX reference design solution:

- Transmitter power consumption in standby mode with analog PING: < 8mA (96mW with 12 V DC input)

3.3 Digital demodulation

To optimize system BOM cost, the WCT1111 solution employs digital demodulation algorithm to communicate with the receiver. This method can achieve high performance, low cost, and very simple coil signal sensing circuit with less components number.

3.4 Two-way communication

The WCT1111 solution supports two-way communication and uses FSK to send messages to receiver. This method allows transmitter to negotiate with receiver to establish advanced power transfer contract, and calibrate power loss for more precise FOD protection.

3.5 Foreign object detection

The WCT1111 solution supports power class 0 FOD framework, which is based on calibrated power loss method and quality factor (Q factor) method. With NXP FreeMASTER GUI tool, the FOD algorithm can be easily calibrated to get accurate power loss information especially for very sensitive foreign objects.

4 Device Information

4.1 Functional block diagram

This functional block diagram shows the functional block pin assignment information of MWCT1111CLH. For the detailed pin multiplexing information, see Section 4.4 “Pin Function Description”.

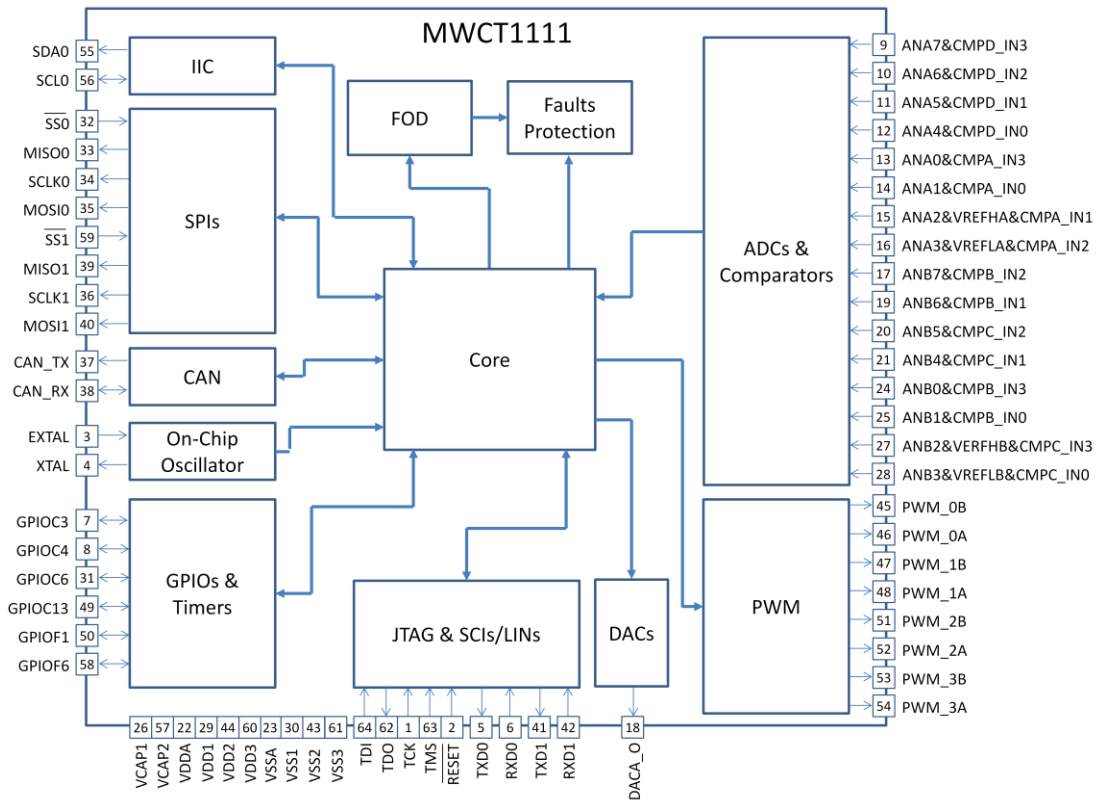

Figure 1. MWCT1111CLH functional block diagram

4.2 Product features overview

The following table lists the main on-chip features of the MWCT1111CLH device.

Table 8. Product features overview

Part	WCT1111
Maximum Core/Bus Clock (MHz)	100/50
Maximum Fully Run Current Consumption (mA)	38.1 (V_{DD}) + 9.9 (V_{DDA})
On-Chip Program Flash Memory Size (KB)	64
On-Chip SRAM Memory Size (KB)	8
Memory Resource Protection	Yes
Inter-Peripheral Crossbar Switches with AOI	Yes
On-Chip Relaxation Oscillator	1 (8 MHz) + 1 (200 kHz)

Windowed Computer Operating Properly		1
External Watchdog Monitor		1
Cyclic Redundancy Check		1
Periodic Interrupt Timer		2
Quad Timer		1 x 4
12-bit Cyclic ADC Channels		2 x 8
PWM Channels	High-Resolution	8
	Standard	4
12-bit DAC		2
Analog Comparator /w 6-bit REF DAC		4
DMA Channels		4
Queued Serial Communications Interface		2
Queued Serial Peripheral Interface		2
Inter-Integrated Circuit		1
Controller Area Network (MSCAN)		1
GPIO		54
Package		64 LQFP

4.3 Pinout diagram

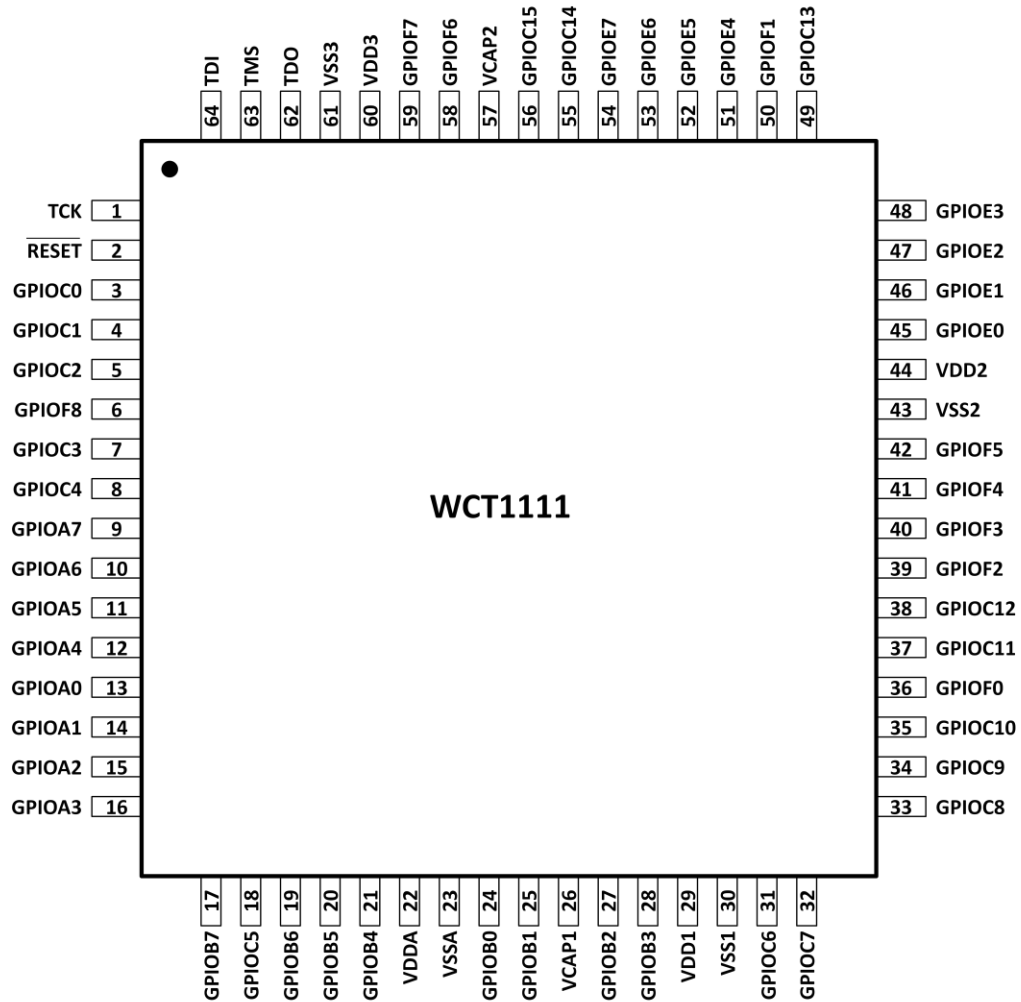

Figure 2. MWCT1111CLH pinout diagram

4.4 Pin function description

By default, each pin is configured for its primary function (listed first). Any alternative functionality, shown in parentheses, can be programmed through GPIO module peripheral enable registers and SIM module GPIO peripheral select registers.

Table 9. Pin signal descriptions

Signal name	Pin No.	Multiplexing signals	Function description
TCK	1	GPIOD2	Test Clock Input — This input pin provides a gated clock to synchronize the test logic and shift serial data to the JTAG/EOnCE port. The pin is connected internally to a pull-up resistor. A Schmitt-trigger input is used for noise immunity.

			<p>Port D GPIO — This GPIO pin can be individually programmed as an input or output pin.</p> <p>After reset, the default state is TCK.</p>
$\overline{\text{RESET}}$	2	GPIOD4	<p>$\overline{\text{RESET}}$ — This input is a direct hardware reset on the processor. When $\overline{\text{RESET}}$ is asserted low, the device is initialized and placed in the reset state. A Schmitt-trigger input is used for noise immunity. The internal reset signal is de-asserted synchronous with the internal clocks after a fixed number of internal clocks.</p> <p>Port D GPIO — This GPIO pin can be individually programmed as an input or output pin. If $\overline{\text{RESET}}$ functionality is disabled in this mode and the chip can be reset only via POR, COP reset, or software reset.</p> <p>After reset, the default state is $\overline{\text{RESET}}$.</p>
GPIOC0	3	EXTAL/CLKIN0	<p>Port C GPIO — This GPIO pin can be individually programmed as an input or output pin.</p> <p>EXTAL — External Crystal Oscillator Input. This input connects the internal crystal oscillator input to an external crystal or ceramic resonator.</p> <p>CLKIN0 — This pin serves as an external clock input 0.</p> <p>After reset, the default state is GPIOC0.</p>
GPIOC1	4	XTAL	<p>Port C GPIO — This GPIO pin can be individually programmed as an input or output pin.</p> <p>XTAL — External Crystal Oscillator Output. This output connects the internal crystal oscillator output to an external crystal or ceramic resonator.</p> <p>After reset, the default state is GPIOC1.</p>
GPIOC2	5	TXD0/XB_OUT11/ XB_IN2/CLKO0	<p>Port C GPIO — This GPIO pin can be individually programmed as an input or output pin.</p> <p>TXD0 — The SCI0 transmit data output or transmit/receive in single wire operation.</p> <p>XB_OUT11 — Crossbar module output 11.</p> <p>XB_IN2 — Crossbar module input 2.</p> <p>CLKO0 — This is a buffered clock output 0; the clock source is selected by clock out select (CLKOSEL) bits in the clock output select register (CLKOUT) of the SIM.</p> <p>After reset, the default state is GPIOC2.</p>
GPIOF8	6	RXD0/XB_OUT10 /CMPD_O/PWM_2X	<p>Port F GPIO — This GPIO pin can be individually programmed as an input or output pin.</p> <p>RXD0 — The SCI0 receive data input.</p> <p>XB_OUT10 — Crossbar module output 10.</p> <p>CMPD_O — Analog comparator D output.</p> <p>PWM_2X — NanoEdge eFlexPWM sub-module 2 output X or input capture X.</p> <p>After reset, the default state is GPIOF8.</p>

GPIOC3	7	TA0/CMPA_O/RXD0/CLKIN1	<p>Port C GPIO — This GPIO pin can be individually programmed as an input or output pin.</p> <p>TA0 — Quad timer module A channel 0 input/output.</p> <p>CMPA_O — Analog comparator A output.</p> <p>RXD0 — The SCI0 receive data input.</p> <p>CLKIN1 — This pin serves as an external clock input 1.</p> <p>After reset, the default state is GPIOC3.</p>
GPIOC4	8	TA1/CMPB_O/XB_IN6/EWM_OUT	<p>Port C GPIO — This GPIO pin can be individually programmed as an input or output pin.</p> <p>TA1 — Quad timer module A channel 1 input/output.</p> <p>CMPB_O — Analog comparator B output.</p> <p>XB_IN6 — Crossbar module input 6.</p> <p>EWM_OUT — External watchdog monitor output.</p> <p>After reset, the default state is GPIOC4.</p>
GPIOA7	9	ANA7&CMPD_IN3	<p>Port A GPIO — This GPIO pin can be individually programmed as an input or output pin.</p> <p>ANA7&CMPD_IN3 — Analog input to channel 7 of ADCA and input 3 of analog comparator D. When used as an analog input, the signal goes to the ANA7 and CMPD_IN3.</p> <p>After reset, the default state is GPIOA7.</p>
GPIOA6	10	ANA6&CMPD_IN2	<p>Port A GPIO — This GPIO pin can be individually programmed as an input or output pin.</p> <p>ANA6&CMPD_IN2 — Analog input to channel 6 of ADCA and input 2 of analog comparator D. When used as an analog input, the signal goes to the ANA6 and CMPD_IN2.</p> <p>After reset, the default state is GPIOA6.</p>
GPIOA5	11	ANA5&CMPD_IN1	<p>Port A GPIO — This GPIO pin can be individually programmed as an input or output pin.</p> <p>ANA5&CMPD_IN1 — Analog input to channel 5 of ADCA and input 1 of analog comparator D. When used as an analog input, the signal goes to the ANA5 and CMPD_IN1.</p> <p>After reset, the default state is GPIOA5.</p>
GPIOA4	12	ANA4&CMPD_IN0	<p>Port A GPIO — This GPIO pin can be individually programmed as an input or output pin.</p> <p>ANA4&CMPD_IN0 — Analog input to channel 4 of ADCA and input 0 of analog comparator D. When used as an analog input, the signal goes to the ANA4 and CMPD_IN0.</p> <p>After reset, the default state is GPIOA4.</p>
GPIOA0	13	ANA0&CMPA_IN3 /CMPC_O	<p>Port A GPIO — This GPIO pin can be individually programmed as an input or output pin.</p> <p>ANA0&CMPA_IN3 — Analog input to channel 0 of ADCA and input 3 of</p>

			<p>analog comparator A. When used as an analog input, the signal goes to the ANA0 and CMPA_IN3.</p> <p>CMPC_O — Analog comparator C output.</p> <p>After reset, the default state is GPIOA0.</p>
GPIOA1	14	ANA1&CMPA_IN0	<p>Port A GPIO — This GPIO pin can be individually programmed as an input or output pin.</p> <p>ANA1 and CMPA_IN0 — Analog input to channel 1 of ADCA and input 0 of analog comparator A. When used as an analog input, the signal goes to the ANA1 and CMPA_IN0.</p> <p>After reset, the default state is GPIOA1.</p>
GPIOA2	15	ANA2&VREFHA&CMPA_IN1	<p>Port A GPIO — This GPIO pin can be individually programmed as an input or output pin.</p> <p>ANA2&VREFHA&CMPA_IN1 — Analog input to channel 2 of ADCA and analog references high of ADCA and input 1 of analog comparator A. When used as an analog input, the signal goes to ANA2 and VREFHA and CMPA_IN1. ADC control register configures this input as ANA2 or VREFHA.</p> <p>After reset, the default state is GPIOA2.</p>
GPIOA3	16	ANA3&VREFLA&CMPA_IN2	<p>Port A GPIO — This GPIO pin can be individually programmed as an input or output pin.</p> <p>ANA3&VREFLA&CMPA_IN2 — Analog input to channel 3 of ADCA and analog references low of ADCA and input 2 of analog comparator A. When used as an analog input, the signal goes to ANA3 and VREFLA and CMPA_IN2. ADC control register configures this input as ANA3 or VREFLA.</p> <p>After reset, the default state is GPIOA3.</p>
GPIOB7	17	ANB7&CMPB_IN2	<p>Port B GPIO — This GPIO pin can be individually programmed as an input or output pin.</p> <p>ANB7&CMPB_IN2 — Analog input to channel 7 of ADCB and input 2 of analog comparator B. When used as an analog input, the signal goes to the ANB7 and CMPB_IN2.</p> <p>After reset, the default state is GPIOB7.</p>
GPIOC5	18	DACA_O/XB_IN7	<p>Port C GPIO — This GPIO pin can be individually programmed as an input or output pin.</p> <p>DACA_O — 12-bit Digital-to-Analog Converter A output.</p> <p>XB_IN7 — Crossbar module input 7.</p> <p>After reset, the default state is GPIOC5.</p>
GPIOB6	19	ANB6&CMPB_IN1	<p>Port B GPIO — This GPIO pin can be individually programmed as an input or output pin.</p> <p>ANB6&CMPB_IN1 — Analog input to channel 6 of ADCB and input 1 of analog comparator B. When used as an analog input, the signal goes to the ANB6 and CMPB_IN1.</p> <p>After reset, the default state is GPIOB6.</p>
GPIOB5	20	ANB5&CMPC_IN2	<p>Port B GPIO — This GPIO pin can be individually programmed as an input or output pin.</p>

			<p>ANB5&CMPC_IN2 — Analog input to channel 5 of ADCB and input 2 of analog comparator C. When used as an analog input, the signal goes to the ANB5 and CMPC_IN2.</p> <p>After reset, the default state is GPIOB5.</p>
GPIOB4	21	ANB4&CMPC_IN1	<p>Port B GPIO — This GPIO pin can be individually programmed as an input or output pin.</p> <p>ANB4&CMPC_IN1 — Analog input to channel 4 of ADCB and input 1 of analog comparator C. When used as an analog input, the signal goes to the ANB4 and CMPC_IN1.</p> <p>After reset, the default state is GPIOB4.</p>
VDDA	22	-	Analog Power — This pin supplies 3.3 V power to the analog modules. It must be connected to a clean analog power supply.
VSSA	23	-	Analog Ground — This pin supplies an analog ground to the analog modules. It must be connected to a clean power supply.
GPIOB0	24	ANB0&CMPB_IN3	<p>Port B GPIO — This GPIO pin can be individually programmed as an input or output pin.</p> <p>ANB0&CMPB_IN3 — Analog input to channel 0 of ADCB and input 3 of analog comparator B. When used as an analog input, the signal goes to ANB0 and CMPB_IN3.</p> <p>After reset, the default state is GPIOB0.</p>
GPIOB1	25	ANB1&CMPB_IN0 /DACB_O	<p>Port B GPIO — This GPIO pin can be individually programmed as an input or output pin.</p> <p>ANB1&CMPB_IN0 — Analog input to channel 1 of ADCB and input 0 of analog comparator B. When used as an analog input, the signal goes to ANB1 and CMPB_IN0.</p> <p>DACB_O — 12-bit Digital-to-Analog Converter B output.</p> <p>After reset, the default state is GPIOB1.</p>
VCAP1	26	-	Connect a 2.2 μ F or greater bypass capacitor between this pin and VSS to stabilize the core voltage regulator output required for proper device operation.
GPIOB2	27	ANB2&VREFHB&CMPC_IN3	<p>Port B GPIO — This GPIO pin can be individually programmed as an input or output pin.</p> <p>ANB2&VREFHB&CMPC_IN3 — Analog input to channel 2 of ADCB and analog references high of ADCB and input 3 of analog comparator C. When used as an analog input, the signal goes to ANB2 and VREFHB and CMPC_IN3. ADC control register configures this input as ANB2 or VREFHB.</p> <p>After reset, the default state is GPIOB2.</p>
GPIOB3	28	ANB3&VREFLB&CMPC_IN0	<p>Port B GPIO — This GPIO pin can be individually programmed as an input or output pin.</p> <p>ANB3&VREFLB&CMPC_IN0 — Analog input to channel 3 of ADCB and analog references low of ADCB and input 0 of analog comparator C. When used as an analog input, the signal goes to ANB3 and VREFLB and CMPC_IN0. ADC control register configures this input as ANB3 or VREFLB.</p> <p>After reset, the default state is GPIOB3.</p>
VDD1	29	-	I/O Power — Supplies 3.3 V power to on-chip digital module.

VSS1	30	-	I/O Ground — Provides ground on-chip digital module.
GPIOC6	31	TA2/XB_IN3/CMP_REF/ $\overline{SS0}$	<p>Port C GPIO — This GPIO pin can be individually programmed as an input or output pin.</p> <p>TA2 — Quad timer module A channel 2 input/output.</p> <p>XB_IN3 — Crossbar module input 3.</p> <p>CMP_REF — Input 5 of analog comparator A and B and C and D.</p> <p>$\overline{SS0}$ — $\overline{SS0}$ is used in slave mode to indicate to the SPI0 module that the current transfer is to be received.</p> <p>After reset, the default state is GPIOC6.</p>
GPIOC7	32	$\overline{SS0}$ /TXD0/XB_IN8	<p>Port C GPIO — This GPIO pin can be individually programmed as an input or output pin.</p> <p>$\overline{SS0}$ — $\overline{SS0}$ is used in slave mode to indicate to the SPI0 module that the current transfer is to be received.</p> <p>TXD0 — SCI0 transmit data output or transmit/receive in single wire operation.</p> <p>XB_IN8 — Crossbar module input 8.</p> <p>After reset, the default state is GPIOC7.</p>
GPIOC8	33	MISO0/RXD0/XB_IN9/XB_OUT6	<p>Port C GPIO — This GPIO pin can be individually programmed as an input or output pin.</p> <p>MISO0 — Master in/slave out. In master mode, this pin serves as the data input. In slave mode, this pin serves as the data output. The MISO0 line of a slave device is placed in the high-impedance state if the slave device is not selected.</p> <p>RXD0 — SCI0 receive data input.</p> <p>XB_IN9 — Crossbar module input 9.</p> <p>XB_OUT6 — Crossbar module output 6.</p> <p>After reset, the default state is GPIOC8.</p>
GPIOC9	34	SCLK0/XB_IN4/TXD0/XB_OUT8	<p>Port C GPIO — This GPIO pin can be individually programmed as an input or output pin.</p> <p>SCLK0 — The SPI0 serial clock. In master mode, this pin serves as an output, clocking slaved listeners. In slave mode, this pin serves as the data clock input.</p> <p>XB_IN4 — Crossbar module input 4.</p> <p>TXD0 — SCI0 transmit data output or transmit/receive in single wire operation.</p> <p>XB_OUT8 — Crossbar module output 8.</p> <p>After reset, the default state is GPIOC9.</p>
GPIOC10	35	MOSI0/XB_IN5/MISO0/XB_OUT9	<p>Port C GPIO — This GPIO pin can be individually programmed as an input or output pin.</p> <p>MOSI0 — Master out/slave in. In master mode, this pin serves as the data</p>

			<p>output. In slave mode, this pin serves as the data input.</p> <p>XB_IN5 — Crossbar module input 5.</p> <p>MISO0 — Master in/slave out. In master mode, this pin serves as the data input. In slave mode, this pin serves as the data output. The MISO0 line of a slave device is placed in the high-impedance state if the slave device is not selected.</p> <p>XB_OUT9 — Crossbar module output 9.</p> <p>After reset, the default state is GPIOC10.</p>
GPIOF0	36	XB_IN6/SCLK1	<p>Port F GPIO — This GPIO pin can be individually programmed as an input or output pin.</p> <p>XB_IN6 — Crossbar module input 6.</p> <p>SCLK1 — The SPI1 serial clock. In master mode, this pin serves as an output, clocking slaved listeners. In slave mode, this pin serves as the data clock input.</p> <p>After reset, the default state is GPIOF0.</p>
GPIOC11	37	CAN_TX/SCL0/TXD1	<p>Port C GPIO — This GPIO pin can be individually programmed as an input or output pin.</p> <p>CANTX — CAN transmit data output.</p> <p>SCL0 — IIC0 serial clock.</p> <p>TXD1 — SCI1 transmit data output or transmit/receive in single wire operation.</p> <p>After reset, the default state is GPIOC11.</p>
GPIOC12	38	CAN_RX/SDA0/RXD1	<p>Port C GPIO — This GPIO pin can be individually programmed as an input or output pin.</p> <p>CANRX — CAN receive data input.</p> <p>SDA0 — IIC0 serial data line.</p> <p>RXD1 — SCI1 receive data input.</p> <p>After reset, the default state is GPIOC12.</p>
GPIOF2	39	SCL0/XB_OUT6/MISO1	<p>Port F GPIO — This GPIO pin can be individually programmed as an input or output pin.</p> <p>SCL0 — IIC0 serial clock.</p> <p>XB_OUT6 — Crossbar module output 6.</p> <p>MISO1 — Master in/slave out. In master mode, this pin serves as the data input. In slave mode, this pin serves as the data output. The MISO1 line of a slave device is placed in the high-impedance state if the slave device is not selected.</p> <p>After reset, the default state is GPIOF2.</p>
GPIOF3	40	SDA0/XB_OUT7/MOSI1	<p>Port F GPIO — This GPIO pin can be individually programmed as an input or output pin.</p> <p>SDA0 — IIC0 serial data line.</p>

			<p>XB_OUT7 — Crossbar module output 7.</p> <p>MOSI1 — Master out/slave in. In master mode, this pin serves as the data output. In slave mode, this pin serves as the data input.</p> <p>After reset, the default state is GPIOF3.</p>
GPIOF4	41	TXD1/XB_OUT8/ PWM_0X/PWM_F AULT6	<p>Port F GPIO — This GPIO pin can be individually programmed as an input or output pin.</p> <p>TXD1 — The SCI1 transmit data output or transmit/receive in single wire operation.</p> <p>XB_OUT8 — Crossbar module output 8.</p> <p>PWM_0X — NanoEdge eFlexPWM sub-module 0 output X or input capture X.</p> <p>PWM_FAULT6 — NanoEdge eFlexPWM fault input 6.</p> <p>After reset, the default state is GPIOF4.</p>
GPIOF5	42	RXD1/XB_OUT9/ PWM_1X/PWM_F AULT7	<p>Port F GPIO — This GPIO pin can be individually programmed as an input or output pin.</p> <p>RXD1 — The SCI1 receive data input.</p> <p>XB_OUT9 — Crossbar module output 9.</p> <p>PWM_1X — NanoEdge eFlexPWM sub-module 1 output X or input capture X.</p> <p>PWM_FAULT7 — NanoEdge eFlexPWM fault input 7.</p> <p>After reset, the default state is GPIOF5.</p>
VSS2	43	-	I/O Ground — Provides ground to on-chip digital module.
VDD2	44	-	I/O Power — Supplies 3.3 V power to on-chip digital module.
GPIOE0	45	PWM_0B	<p>Port E GPIO — This GPIO pin can be individually programmed as an input or output pin.</p> <p>PWM_0B — NanoEdge eFlexPWM sub-module 0 output B or input capture B.</p> <p>After reset, the default state is GPIOE0.</p>
GPIOE1	46	PWM_0A	<p>Port E GPIO — This GPIO pin can be individually programmed as an input or output pin.</p> <p>PWM_0A — NanoEdge eFlexPWM sub-module 0 output A or input capture A.</p> <p>After reset, the default state is GPIOE1.</p>
GPIOE2	47	PWM_1B	<p>Port E GPIO — This GPIO pin can be individually programmed as an input or output pin.</p> <p>PWM_1B — NanoEdge eFlexPWM sub-module 1 output B or input capture B.</p> <p>After reset, the default state is GPIOE2.</p>
GPIOE3	48	PWM_1A	<p>Port E GPIO — This GPIO pin can be individually programmed as an input or output pin.</p> <p>PWM_1A — NanoEdge eFlexPWM sub-module 1 output A or input capture</p>

			A. After reset, the default state is GPIOE3.
GPIOC13	49	TA3/XB_IN6/ EWM_OUT	Port C GPIO — This GPIO pin can be individually programmed as an input or output pin. TA3 — Quad timer module A channel 3 input/output. XB_IN6 — Crossbar module input 6. EWM_OUT — External watchdog monitor output. After reset, the default state is GPIOC13.
GPIOF1	50	CLKO1/XB_IN7/C MPD_O	Port F GPIO — This GPIO pin can be individually programmed as an input or output pin. CLKO1 — This is a buffered clock output 1; the clock source is selected by clock out select (CLKOSEL) bits in the clock output select register (CLKOUT) of the SIM. XB_IN7 — Crossbar module input 7. CMPD_O — Analog comparator D output. After reset, the default state is GPIOF1.
GPIOE4	51	PWM_2B/XB_IN2	Port E GPIO — This GPIO pin can be individually programmed as an input or output pin. PWM_2B — NanoEdge eFlexPWM sub-module 2 output B or input capture B. XB_IN2 — Crossbar module input 2. After reset, the default state is GPIOE4.
GPIOE5	52	PWM_2A/XB_IN3	Port E GPIO — This GPIO pin can be individually programmed as an input or output pin. PWM_2A — NanoEdge eFlexPWM sub-module 2 output A or input capture A. XB_IN3 — Crossbar module input 3. After reset, the default state is GPIOE5.
GPIOE6	53	PWM_3B/XB_IN4	Port E GPIO — This GPIO pin can be individually programmed as an input or output pin. PWM_3B — NanoEdge eFlexPWM sub-module 3 output B or input capture B. XB_IN4 — Crossbar module input 4. After reset, the default state is GPIOE6.
GPIOE7	54	PWM_3A/XB_IN5	Port E GPIO — This GPIO pin can be individually programmed as an input or output pin. PWM_3A — NanoEdge eFlexPWM sub-module 3 output A or input capture A. XB_IN5 — Crossbar module input 5.

			After reset, the default state is GPIOE7.
GPIOC14	55	SDA0/XB_OUT4/ PWM_FAULT4	Port C GPIO — This GPIO pin can be individually programmed as an input or output pin. SDA0 — IIC0 serial data line. XB_OUT4 — Crossbar module output 4. PWM_FAULT4 — NanoEdge eFlexPWM fault input 4. After reset, the default state is GPIOC14.
GPIOC15	56	SCL0/XB_OUT5/ WM_FAULT5	Port C GPIO — This GPIO pin can be individually programmed as an input or output pin. SCL0 — IIC0 serial clock. XB_OUT5 — Crossbar module output 5. PWM_FAULT5 — NanoEdge eFlexPWM fault input 5. After reset, the default state is GPIOC15.
VCAP2	57	-	Connect a 2.2 μ F or greater bypass capacitor between this pin and VSS to stabilize the core voltage regulator output required for proper device operation.
GPIOF6	58	PWM_3X/XB_IN2	Port F GPIO — This GPIO pin can be individually programmed as an input or output pin. PWM_3X — NanoEdge eFlexPWM sub-module 3 output X or input capture X. XB_IN2 — Crossbar module input 2. After reset, the default state is GPIOF6.
GPIOF7	59	CMPC_O/ $\overline{SS1}$ /XB_IN3	Port F GPIO — This GPIO pin can be individually programmed as an input or output pin. CMPC_O — Analog comparator C output. $\overline{SS1}$ — $\overline{SS1}$ is used in slave mode to indicate to the SPI1 module that the current transfer is to be received. XB_IN3 — Crossbar module input 3. After reset, the default state is GPIOF7.
VDD3	60	-	I/O Power — Supplies 3.3 V power to on-chip digital module.
VSS3	61	-	I/O Ground — Provides ground to on-chip digital module.
TDO	62	GPIOD1	Test Data Output — This tri-stateable output pin provides a serial output data stream from the JTAG/EOnCE port. It is driven in the shift-IR and shift-DR controller states, and changes on the falling edge of TCK. Port D GPIO — This GPIO pin can be individually programmed as an input or output pin. After reset, the default state is TDO.
TMS	63	GPIOD3	Test Mode Select Input — This input pin is used to sequence the JTAG TAP controller's state machine. It is sampled on the rising edge of TCK and has an on-chip pull-up resistor. Port D GPIO — This GPIO pin can be individually programmed as an input or output pin.

			<p>After reset, the default state is TMS.</p> <p>NOTE: Always tie the TMS pin to VDD through a 2.2 kΩ resistor if need to keep on-board debug capability. Otherwise, directly tie to VDD.</p>
TDI	64	GPIOD0	<p>Test Data Input — This input pin provides a serial input data stream to the JTAG/EOnCE port. It is sampled on the rising edge of TCK and has an on-chip pull-up resistor.</p> <p>Port D GPIO — This GPIO pin can be individually programmed as an input or output pin.</p> <p>After reset, the default state is TDI.</p>

4.5 Ordering information

Table 10 lists the pertinent information needed to place an order. Consult a NXP Semiconductors sales office to determine availability and to order this device.

Table 10 MWCT1111CLH ordering information

Device	Supply Voltage	Package Type	Pin Count	Ambient Temp.	Order Number
MWCT1111CLH	3.0 to 3.6V	LQFP	64	-40 to +85°C	MWCT1111CLH

4.6 Package outline drawing

To find a package drawing, go to nxp.com and perform a keyword search for the drawing's document number of 98ASS23234W.

5 Software Library

WCT1111 does not only run the core wireless charging function, but also allows the user to add user application functions. NXP provides a Wireless Charging Transmitter (WCT) software library to speed user designs for different solutions designed with WCT1111. In the library, low level drivers of HAL (Hardware Abstract Layer), callback functions for library access are open to the user. For the software API and library details, see WCT1x1x TX Library User's Guide in the WCT-15W1COILTX reference design platform.

5.1 Memory map

WCT1111 has large on-chip Flash memory and RAM for user design. Besides for wireless charging transmitter library code, the user can develop private functions and link them to the library through predefined APIs.

Table 11. WCT1111 memory footprint

Part	Memory	Total size	Example code size	Library size	FreeMASTER size	Free size
WCT1111	Flash	64 Kbytes	40.8 Kbyte	26.8 Kbytes	1.5 Kbytes	23.2 Kbytes
	RAM	8 Kbytes	4.67 Kbyte	3.4 Kbytes	0.1 Kbytes	3.33 Kbytes

5.2 Software library and API description

For more information about the WCT software library and API definition, see the WCT1x1x TX Library User's Guide in the WCT-15W1COILTX reference design platform.

6 Design Considerations

6.1 Electrical design considerations

Use the following list of considerations to assure correct operation of the device and system:

- The minimum bypass requirement is to place 0.01 - 0.1 μ F capacitors positioned as near as possible to the package supply pins. The recommended bypass configuration is to place one bypass capacitor on each of the VDD/VSS pairs, including VDDA/VSSA. Ceramic and tantalum capacitors tend to provide better tolerances.
- Bypass the VDD and VSS with approximately 10 μ F, plus the number of 0.1 μ F ceramic capacitors.
- Consider all device loads as well as parasitic capacitance due to PCB traces when calculating capacitance. This is especially critical in systems with higher capacitive loads that could create higher transient currents in the VDD and VSS circuits.
- Take special care to minimize noise levels on the VDDA, and VSSA pins.
- Using separate power planes for VDD and VDDA and separate ground planes for VSS and VSSA are recommended. Connect the separate analog and digital power and ground planes as near as possible to power supply outputs. If analog circuit and digital circuit are powered by the same power supply, connect a small inductor or ferrite bead in serial with VDDA trace.
- If desired, connect an external RC circuit to the RESET pin. The resistor value should be in the range of 4.7 k Ω – 10 k Ω ; and the capacitor value should be in the range of 0.1 μ F – 4.7 μ F.
- Add a 2.2 k Ω external pull-up on the TMS pin of the JTAG port to keep device in a restate during normal operation if JTAG converter is not present.
- During reset and after reset but before I/O initialization, all I/O pins are at input mode with internal weak pull-up.
- To eliminate PCB trace impedance effect, each ADC input should have a no less than 33 pF/10 Ω RC filter.
- To assure chip reliable operation, reserve enough margins for chip electrical design. Figure 3 shows the relationship between electrical ratings and electrical operating characteristics for correct chip operation.

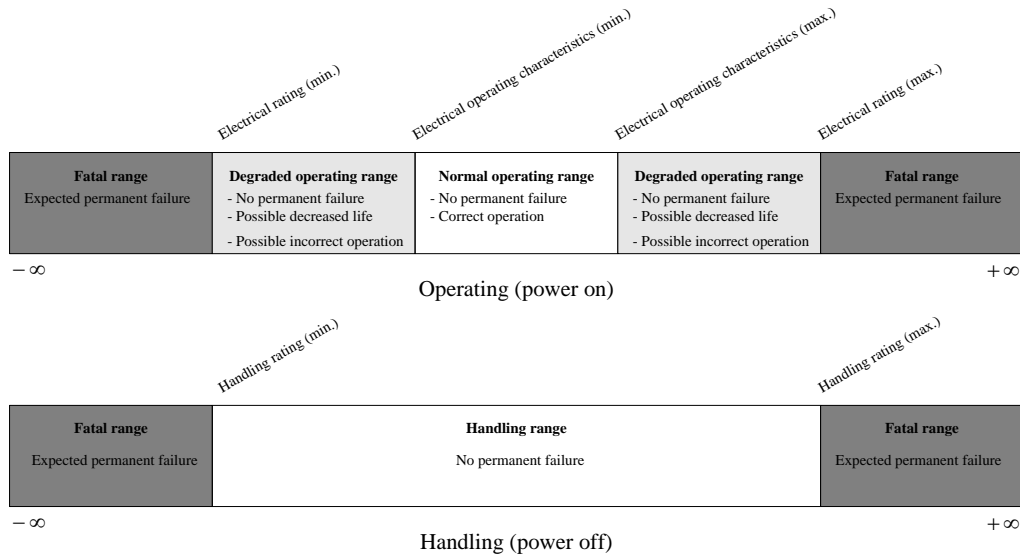

Figure 3. Relationship between ratings and operating characteristics

6.2 PCB layout considerations

- Provide a low-impedance path from the board power supply to each VDD pin on the device and from the board ground to each VSS pin.
- Ensure that capacitor leads and associated printed circuit traces that connect to the chip VDD and VSS pins are as short as possible.
- PCB trace lengths should be minimal for high-frequency signals.
- Physically separate analog components from noisy digital components by ground planes. Do not place an analog trace in parallel with digital traces. Place an analog ground trace around an analog signal trace to isolate it from digital traces.
- The decoupling capacitors of 0.1 μ F must be placed on the VDD pins as close as possible, and place those ceramic capacitors on the same PCB layer with WCT1111 device. VIA is not recommend between the VDD pins and decoupling capacitors.
- As the Wireless Charging system functions as a switching-mode power supply, the power components layout is very important to the whole system power transfer efficiency and EMI performance. The power routing loop should be as small and short as possible, especially for the resonant network. The traces of this circuit should be short and wide, and the current loop should be optimized smaller for the MOSFETs, resonant capacitor and primary coil. Another important thing is that the control circuit and power circuit should be separated.

6.3 Thermal design considerations

WCT1111 power consumption is not so critical, so there is not additional part needed for power dissipation. However, the power inverter needs an additional PCB Cu copper to dissipate the heat, so good

thermal package MOSFET is recommended to select, such as DFN package, and for the resonant capacitor, COG material, and 1206 package is recommended to meet the thermal requirement. The worst thermal case is on the inverter, so the user should make some special actions to dissipate the heat for good transmitter system thermal performance.

7 Links

- nxp.com
- nxp.com/products/power-management/wireless-charging-ics
- www.wirelesspowerconsortium.com

8 Revision History

This table summarizes revisions to this document.

Table 12. Revision history

Revision number	Date	Substantial changes
1.0	12/2014	Initial release.
1.1	09/2016	Some wordings are updated according to the latest WPC Qi specifications.

How to Reach Us:

Home Page:

www.nxp.com

Web Support:

www.nxp.com/support

Information in this document is provided solely to enable system and software implementers to use Freescale products. There are no express or implied copyright licenses granted hereunder to design or fabricate any integrated circuits based on the information in this document.

Freescale reserves the right to make changes without further notice to any products herein. Freescale makes no warranty, representation, or guarantee regarding the suitability of its products for any particular purpose, nor does Freescale assume any liability arising out of the application or use of any product or circuit, and specifically disclaims any and all liability, including without limitation consequential or incidental damages. "Typical" parameters that may be provided in Freescale data sheets and/or specifications can and do vary in different applications, and actual performance may vary over time. All operating parameters, including "typicals," must be validated for each customer application by customer's technical experts. Freescale does not convey any license under its patent rights nor the rights of others. Freescale sells products pursuant to standard terms and conditions of sale, which can be found at the following address: nxp.com/SalesTermsandConditions.

Freescale, the Freescale logo, and Kinetis are trademarks of Freescale Semiconductor, Inc., Reg. U.S. Pat. & Tm. Off. All other product or service names are the property of their respective owners. All rights reserved.

© 2016 Freescale Semiconductor, Inc. All rights reserved.

Document Number: WCT1111DS
Rev. 1.1
09/2016

