



# VN920 VN920-B5 / VN920SO

## SINGLE CHANNEL HIGH SIDE SOLID STATE RELAY

TYPE	$R_{DS(on)}$	$I_{OUT}$	$V_{CC}$
VN920			
VN920-B5	16m $\Omega$	30 A	36 V
VN920SO			

- CMOS COMPATIBLE INPUT
- PROPORTIONAL LOAD CURRENT SENSE
- SHORTED LOAD PROTECTION
- UNDERVOLTAGE AND OVERVOLTAGE SHUTDOWN
- OVERVOLTAGE CLAMP
- THERMAL SHUTDOWN
- CURRENT LIMITATION
- PROTECTION AGAINST LOSS OF GROUND AND LOSS OF  $V_{CC}$
- VERY LOW STAND-BY POWER DISSIPATION
- REVERSE BATTERY PROTECTION (\*)

### DESCRIPTION

The VN920, VN920-B5, VN920SO is a monolithic device made by using STMicroelectronics VIPower M0-3 Technology, intended for driving any kind of load with one side connected to

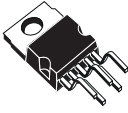

**PENTAWATT**

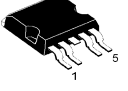

**P<sup>2</sup>PAK**

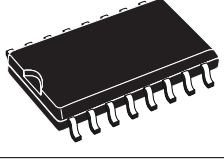

**SO-16L**

ORDER CODES		
PACKAGE	TUBE	T&R
PENTAWATT	VN920	-
P <sup>2</sup> PAK	VN920-B5	VN920-B513TR
SO-16L	VN920SO	VN920SO13TR

ground. Active  $V_{CC}$  pin voltage clamp protects the device against low energy spikes (see ISO7637 transient compatibility table). Active current limitation combined with thermal shutdown and automatic restart protect the device against overload. The device integrates an analog current sense output which delivers a current proportional to the load current. Device automatically turns off in case of ground pin disconnection.

### BLOCK DIAGRAM

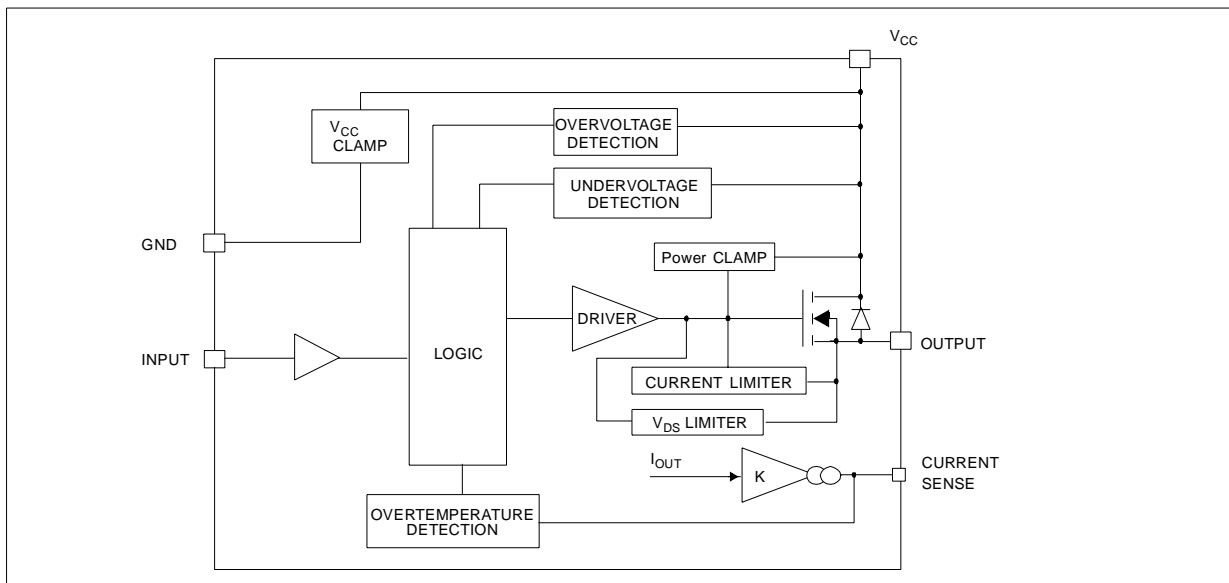

(\*) See application schematic at page 8

**ABSOLUTE MAXIMUM RATING**

Symbol	Parameter	Value			Unit
		PENTAWATT	P <sup>2</sup> PAK	SO-16L	
V <sub>CC</sub>	DC Supply Voltage	41			V
-V <sub>CC</sub>	Reverse DC Supply Voltage	- 0.3			V
-I <sub>GND</sub>	DC Reverse Ground Pin Current	- 200			mA
I <sub>OUT</sub>	DC Output Current	Internally Limited			A
-I <sub>OUT</sub>	Reverse DC Output Current	- 21			A
I <sub>IN</sub>	DC Input Current	+/- 10			mA
V <sub>CSENSE</sub>	Current Sense Maximum Voltage	-3			V
		+15			V
V <sub>ESD</sub>	Electrostatic Discharge (Human Body Model: R=1.5KΩ; C=100pF)				
	- INPUT	4000			V
	- CURRENT SENSE	2000			V
	- OUTPUT	5000			V
	- V <sub>CC</sub>	5000			V
E <sub>MAX</sub>	Maximum Switching Energy (L=0.25mH; R <sub>L</sub> =0Ω; V <sub>bat</sub> =13.5V; T <sub>jstart</sub> =150°C; I <sub>L</sub> =45A)		364	352	mJ
P <sub>TOT</sub>	Power Dissipation T <sub>C</sub> ≤25°C	96.1	96.1	8.3	W
T <sub>j</sub>	Junction Operating Temperature	Internally limited			°C
T <sub>C</sub>	Case Operating Temperature	- 40 to 150			°C
T <sub>STG</sub>	Storage Temperature	- 55 to 150			°C

**CONFIGURATION DIAGRAM (TOP VIEW) & SUGGESTED CONNECTIONS FOR UNUSED AND N.C. PINS**

**SO-16L**

**PENTAWATT**

**P<sup>2</sup>PAK**

Connection / Pin	Current Sense	N.C.	Output	Input
Floating		X	X	X
To Ground	Through 1KΩ resistor	X		Through 10KΩ resistor

**CURRENT AND VOLTAGE CONVENTIONS**

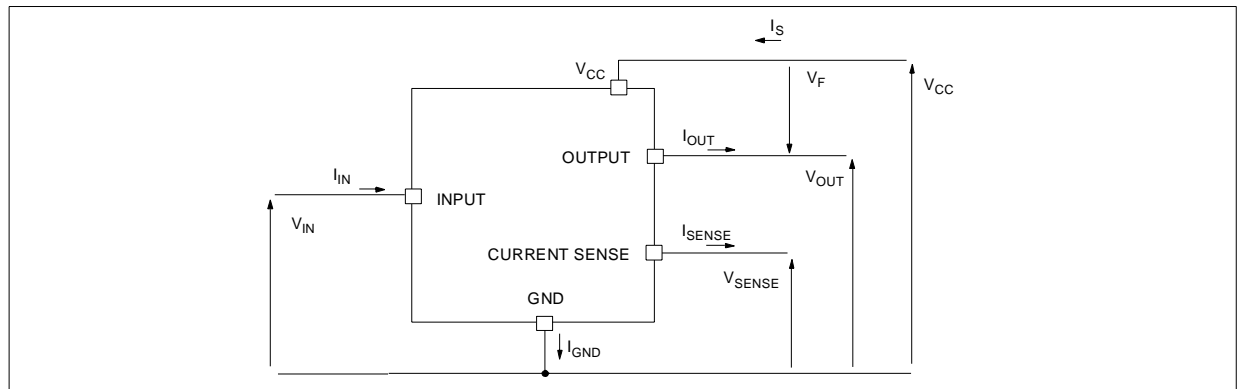

**THERMAL DATA**

Symbol	Parameter		Value			Unit
			PENTAWATT	P <sup>2</sup> PAK	SO-16L	
R <sub>thj-case</sub>	Thermal Resistance Junction-case	Max	1.3	1.3		°C/W
R <sub>thj-lead</sub>	Thermal Resistance Junction-lead	Max			15	°C/W
R <sub>thj-amb</sub>	Thermal Resistance Junction-ambient	Max	61.3	51.3 <sup>(1)</sup>	65 <sup>(3)</sup>	°C/W
				37 <sup>(2)</sup>	48 <sup>(4)</sup>	°C/W

<sup>(1)</sup> When mounted on a standard single-sided FR-4 board with 0.5cm<sup>2</sup> of Cu (at least 35µm thick).

<sup>(2)</sup> When mounted on a standard single-sided FR-4 board with 6cm<sup>2</sup> of Cu (at least 35µm thick).

<sup>(3)</sup> When mounted on a standard single-sided FR-4 board with 0.5cm<sup>2</sup> of Cu (at least 35µm thick) connected to all V<sub>CC</sub> pins.

<sup>(4)</sup> When mounted on a standard single-sided FR-4 board with 6cm<sup>2</sup> of Cu (at least 35µm thick) connected to all V<sub>CC</sub> pins.

**ELECTRICAL CHARACTERISTICS** (8V < V<sub>CC</sub> < 36V; -40°C < T<sub>j</sub> < 150°C unless otherwise specified)

**POWER**

Symbol	Parameter	Test Conditions	Min	Typ	Max	Unit
V <sub>CC</sub>	Operating Supply Voltage		5.5	13	36	V
V <sub>USD</sub>	Undervoltage Shut-down		3	4	5.5	V
V <sub>OV</sub>	Overvoltage Shut-down		36			V
R <sub>ON</sub>	On State Resistance	I <sub>OUT</sub> =10A; T <sub>j</sub> =25°C			16	mΩ
		I <sub>OUT</sub> =10A			32	mΩ
		I <sub>OUT</sub> =3A; V <sub>CC</sub> =6V			55	mΩ
V <sub>clamp</sub>	Clamp Voltage	I <sub>CC</sub> =20mA (See note 1)	41	48	55	V
I <sub>S</sub>	Supply Current	Off State; V <sub>CC</sub> =13V; V <sub>IN</sub> =V <sub>OUT</sub> =0V		10	25	µA
		Off State; V <sub>CC</sub> =13V; V <sub>IN</sub> =V <sub>OUT</sub> =0V; T <sub>j</sub> =25°C		10	20	µA
		On State; V <sub>CC</sub> =13V; V <sub>IN</sub> =5V; I <sub>OUT</sub> =0A; R <sub>SENSE</sub> =3.9KΩ				5
I <sub>L(off1)</sub>	Off State Output Current	V <sub>IN</sub> =V <sub>OUT</sub> =0V	0		50	µA
I <sub>L(off2)</sub>	Off State Output Current	V <sub>IN</sub> =0V; V <sub>OUT</sub> =3.5V	-75		0	µA
I <sub>L(off3)</sub>	Off State Output Current	V <sub>IN</sub> =V <sub>OUT</sub> =0V; V <sub>CC</sub> =13V; T <sub>j</sub> =125°C			5	µA
I <sub>L(off4)</sub>	Off State Output Current	V <sub>IN</sub> =V <sub>OUT</sub> =0V; V <sub>CC</sub> =13V; T <sub>j</sub> =25°C			3	µA

**SWITCHING** (V<sub>CC</sub>=13V)

Symbol	Parameter	Test Conditions	Min	Typ	Max	Unit
t <sub>d(on)</sub>	Turn-on Delay Time	R <sub>L</sub> =1.3Ω (see figure 2)		50		µs
t <sub>d(off)</sub>	Turn-off Delay Time	R <sub>L</sub> =1.3Ω (see figure 2)		50		µs
dV <sub>OUT</sub> /dt <sub>(on)</sub>	Turn-on Voltage Slope	R <sub>L</sub> =1.3Ω (see figure 2)		See relative diagram		V/µs
dV <sub>OUT</sub> /dt <sub>(off)</sub>	Turn-off Voltage Slope	R <sub>L</sub> =1.3Ω (see figure 2)		See relative diagram		V/µs

**ELECTRICAL CHARACTERISTICS** (continued)

**LOGIC INPUT**

Symbol	Parameter	Test Conditions	Min	Typ	Max	Unit
$V_{IL}$	Input Low Level				1.25	V
$I_{IL}$	Low Level Input Current	$V_{IN}=1.25V$	1			$\mu A$
$V_{IH}$	Input High Level		3.25			V
$I_{IH}$	High Level Input Current	$V_{IN}=3.25V$			10	$\mu A$
$V_{I(hyst)}$	Input Hysteresis Voltage		0.5			V
$V_{ICL}$	Input Clamp Voltage	$I_{IN}=1mA$ $I_{IN}=-1mA$	6	6.8 -0.7	8	V V

Note 1:  $V_{clamp}$  and  $V_{OV}$  are correlated. Typical difference is 5V.

**CURRENT SENSE ( $9V \leq V_{CC} \leq 16V$ ) (See Fig. 1)**

Symbol	Parameter	Test Conditions	Min	Typ	Max	Unit
$K_1$	$I_{OUT}/I_{SENSE}$	$I_{OUT}=1A$ ; $V_{SENSE}=0.5V$ ; $T_j = -40^\circ C \dots 150^\circ C$	3300	4400	6000	
$dK_1/K_1$	Current Sense Ratio Drift	$I_{OUT}=1A$ ; $V_{SENSE}=0.5V$ ; $T_j = -40^\circ C \dots +150^\circ C$	-10		+10	%
$K_2$	$I_{OUT}/I_{SENSE}$	$I_{OUT}=10A$ ; $V_{SENSE}=4V$ ; $T_j = -40^\circ C$ $T_j = 25^\circ C \dots 150^\circ C$	4200 4400	4900 4900	6000 5750	
$dK_2/K_2$	Current Sense Ratio Drift	$I_{OUT}=10A$ ; $V_{SENSE}=4V$ ; $T_j = -40^\circ C \dots +150^\circ C$	-8		+8	%
$K_3$	$I_{OUT}/I_{SENSE}$	$I_{OUT}=30A$ ; $V_{SENSE}=4V$ ; $T_j = -40^\circ C$ $T_j = 25^\circ C \dots 150^\circ C$	4200 4400	4900 4900	5500 5250	
$dK_3/K_3$	Current Sense Ratio Drift	$I_{OUT}=30A$ ; $V_{SENSE}=4V$ ; $T_j = -40^\circ C \dots +150^\circ C$	-6		+6	%
$I_{SENSE0}$	Analog Sense Leakage Current	$V_{CC}=6 \dots 16V$ ; $I_{OUT}=0A$ ; $V_{SENSE}=0V$ ; $T_j = -40^\circ C \dots +150^\circ C$	0		10	$\mu A$
$V_{SENSE}$	Max Analog Sense Output Voltage	$V_{CC}=5.5V$ ; $I_{OUT}=5A$ ; $R_{SENSE}=10K\Omega$ $V_{CC}>8V$ ; $I_{OUT}=10A$ ; $R_{SENSE}=10K\Omega$	2 4			V V
$V_{SENSEH}$	Sense Voltage in Overtemperature conditions	$V_{CC}=13V$ ; $R_{SENSE}=3.9K\Omega$		5.5		V
$R_{VSENSEH}$	Analog Sense Output Impedance in Overtemperature Condition	$V_{CC}=13V$ ; $T_j > T_{TSD}$ ; Output Open		400		$\Omega$
$t_{DSENSE}$	Current sense delay response	to 90% $I_{SENSE}$ (see note 2)			500	$\mu s$

Note 2: current sense signal delay after positive input slope.

**ELECTRICAL CHARACTERISTICS** (continued)

## PROTECTIONS (see note 3)

Symbol	Parameter	Test Conditions	Min	Typ	Max	Unit
$T_{TSD}$	Shut-down Temperature		150	175	200	°C
$T_R$	Reset Temperature		135			°C
$T_{hyst}$	Thermal Hysteresis		7	15		°C
$I_{lim}$	DC Short Circuit Current	$V_{CC}=13V$ $5V < V_{CC} < 36V$	30	45	75 75	A A
$V_{demag}$	Turn-off Output Clamp Voltage	$I_{OUT}=2A$ ; $V_{IN}=0V$ ; $L=6mH$	$V_{CC}-41$	$V_{CC}-48$	$V_{CC}-55$	V
$V_{ON}$	Output Voltage Drop Limitation	$I_{OUT}=1A$ ; $T_j=-40^{\circ}C \dots +150^{\circ}C$		50		mV

Note 3: To ensure long term reliability under heavy overload or short circuit conditions, protection and related diagnostic signals must be used together with a proper software strategy. If the device is subjected to abnormal conditions, this software must limit the duration and number of activation cycles.

## VCC - OUTPUT DIODE

Symbol	Parameter	Test Conditions	Min	Typ	Max	Unit
$V_F$	Forward on Voltage	$-I_{OUT}=5A$ ; $T_j=150^{\circ}C$			0.6	V

Figure 1:  $I_{OUT}/I_{SENSE}$  versus  $I_{OUT}$

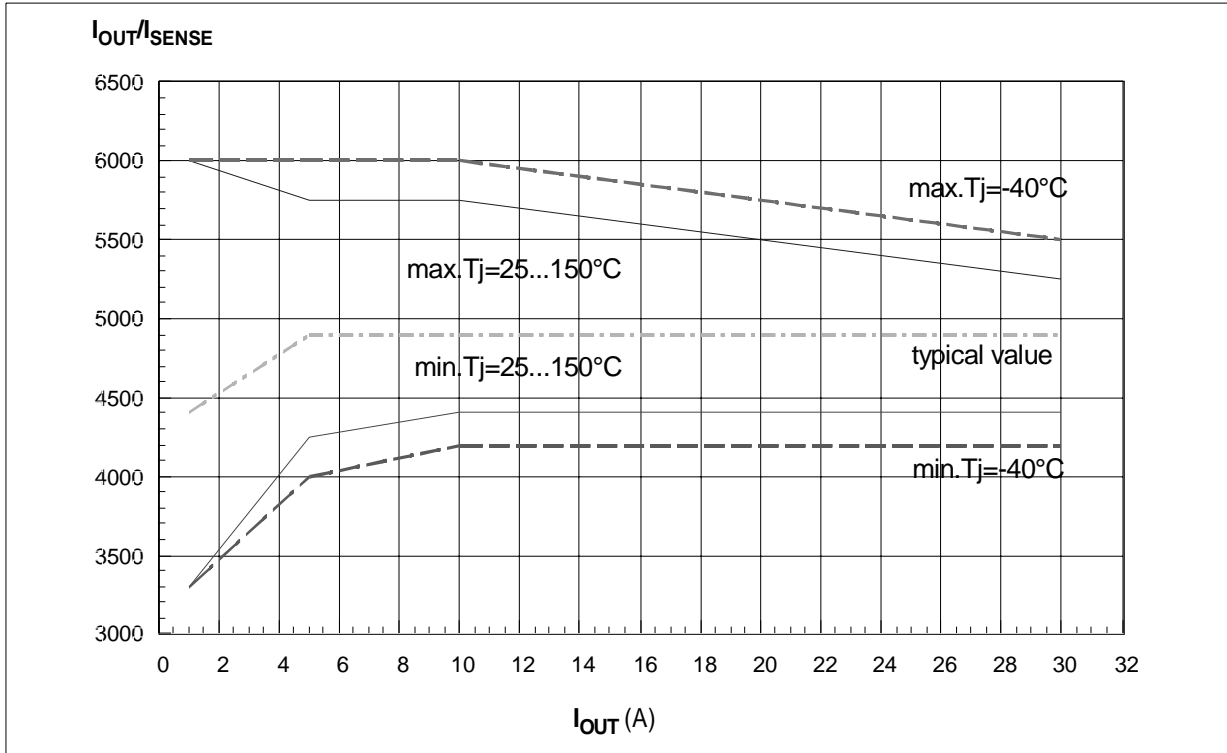
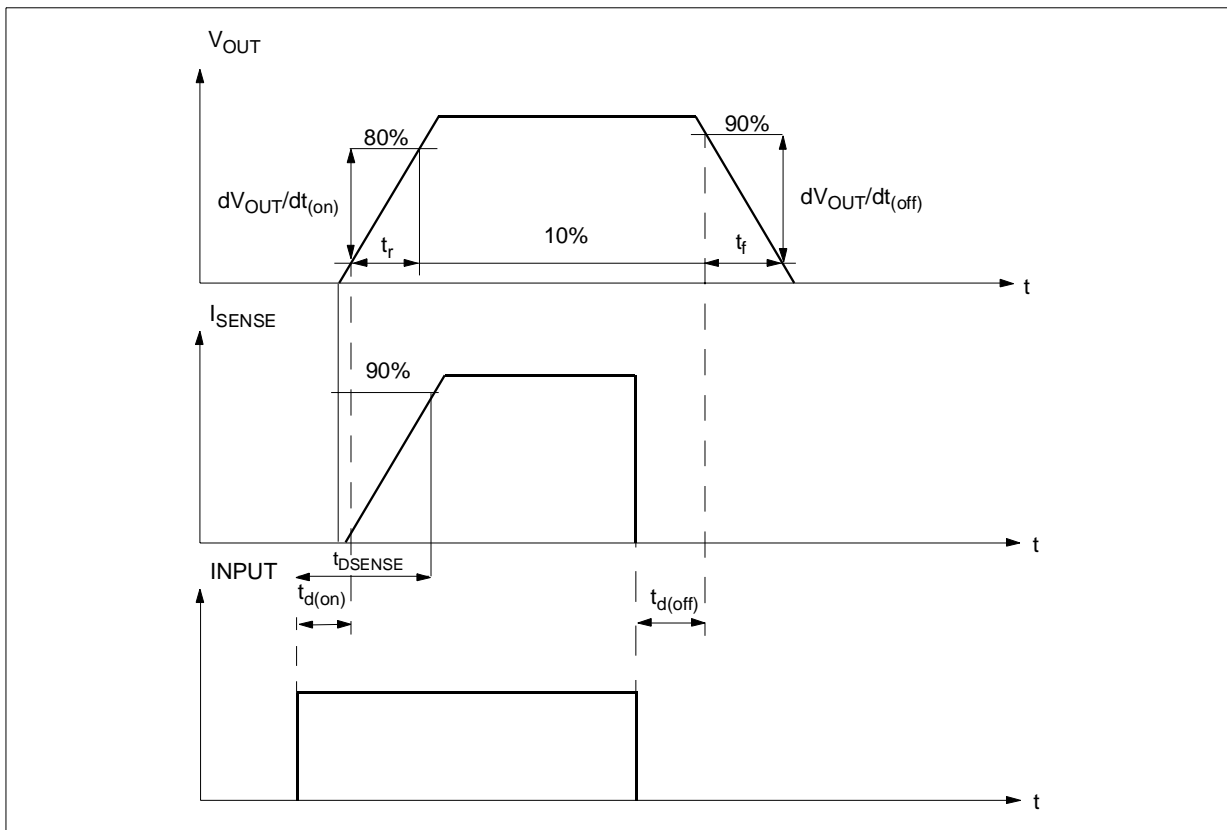

Figure 2: Switching Characteristics (Resistive load  $R_L = 1.3\Omega$ )



**TRUTH TABLE**

CONDITIONS	INPUT	OUTPUT	SENSE
Normal operation	L	L	0
	H	H	Nominal
Overtemperature	L	L	0
	H	L	$V_{SENSEH}$
Undervoltage	L	L	0
	H	L	0
Overvoltage	L	L	0
	H	L	0
Short circuit to GND	L	L	0
	H	L	$(T_j < T_{TSD})$ 0
	H	L	$(T_j > T_{TSD})$ $V_{SENSEH}$
Short circuit to $V_{CC}$	L	H	0
	H	H	< Nominal
Negative output voltage clamp	L	L	0

**ELECTRICAL TRANSIENT REQUIREMENTS**

ISO T/R 7637/1 Test Pulse	TEST LEVELS				Delays and Impedance
	I	II	III	IV	
1	-25 V	-50 V	-75 V	-100 V	2 ms 10 $\Omega$
2	+25 V	+50 V	+75 V	+100 V	0.2 ms 10 $\Omega$
3a	-25 V	-50 V	-100 V	-150 V	0.1 $\mu$ s 50 $\Omega$
3b	+25 V	+50 V	+75 V	+100 V	0.1 $\mu$ s 50 $\Omega$
4	-4 V	-5 V	-6 V	-7 V	100 ms, 0.01 $\Omega$
5	+26.5 V	+46.5 V	+66.5 V	+86.5 V	400 ms, 2 $\Omega$

ISO T/R 7637/1 Test Pulse	TEST LEVELS RESULTS			
	I	II	III	IV
1	C	C	C	C
2	C	C	C	C
3a	C	C	C	C
3b	C	C	C	C
4	C	C	C	C
5	C	E	E	E

CLASS	CONTENTS
C	All functions of the device are performed as designed after exposure to disturbance.
E	One or more functions of the device is not performed as designed after exposure to disturbance and cannot be returned to proper operation without replacing the device.

Figure 3: Waveforms

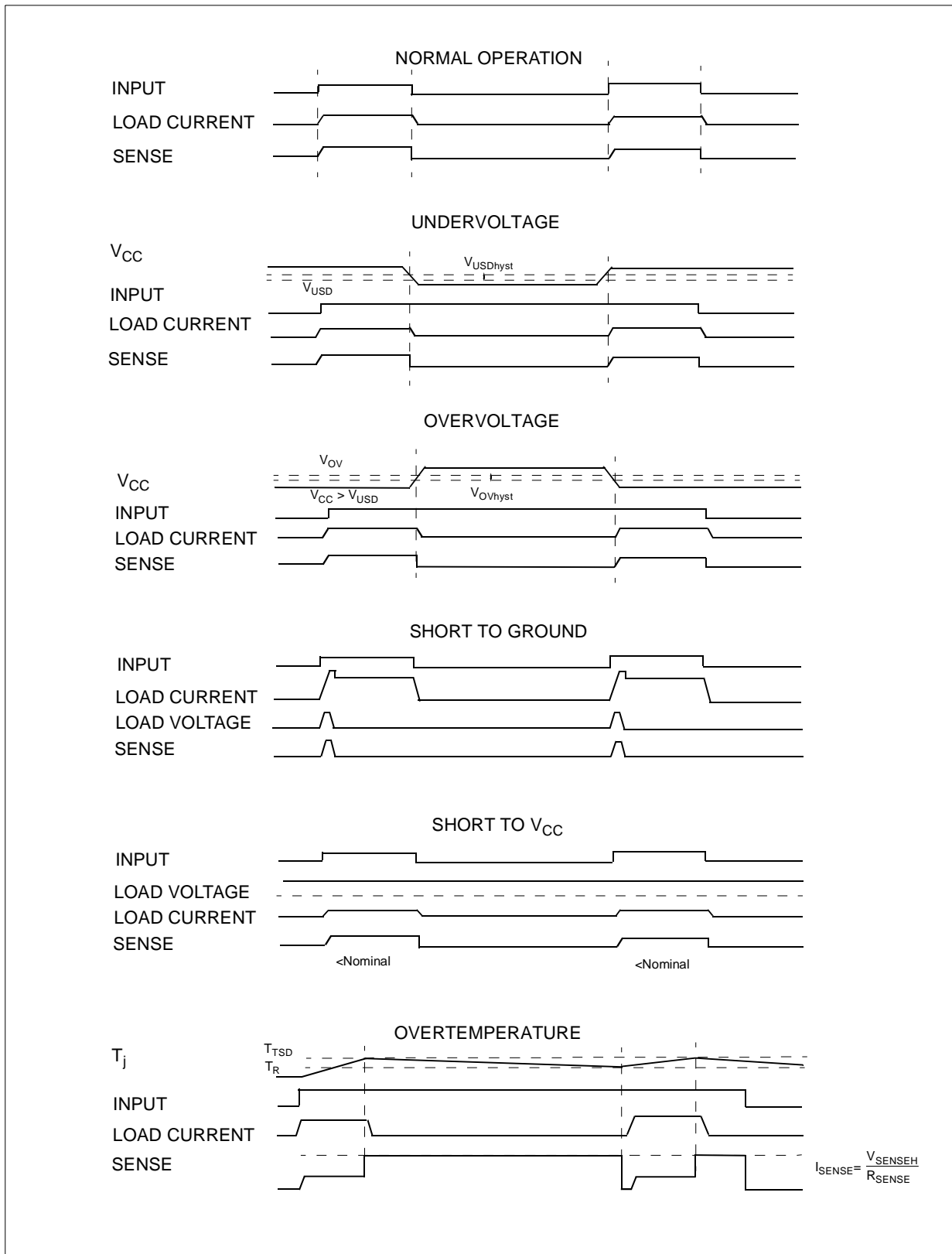



**APPLICATION SCHEMATIC**

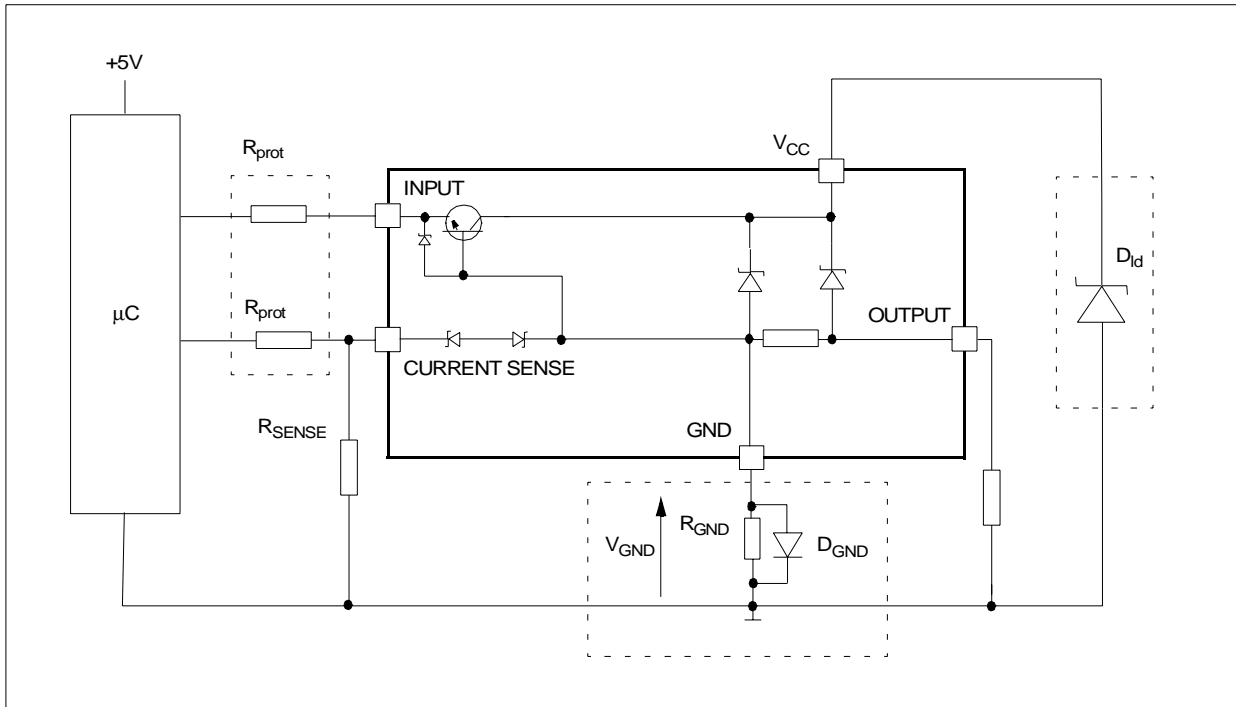

**GND PROTECTION NETWORK AGAINST REVERSE BATTERY**

**Solution 1:** Resistor in the ground line ( $R_{GND}$  only). This can be used with any type of load.

The following is an indication on how to dimension the  $R_{GND}$  resistor.

- 1)  $R_{GND} \leq 600mV / (I_{S(on)max})$ .
- 2)  $R_{GND} \geq (-V_{CC}) / (-I_{GND})$

where  $-I_{GND}$  is the DC reverse ground pin current and can be found in the absolute maximum rating section of the device's datasheet.

Power Dissipation in  $R_{GND}$  (when  $V_{CC} < 0$ : during reverse battery situations) is:

$$P_D = (-V_{CC})^2 / R_{GND}$$

This resistor can be shared amongst several different HSD. Please note that the value of this resistor should be calculated with formula (1) where  $I_{S(on)max}$  becomes the sum of the maximum on-state currents of the different devices.

Please note that if the microprocessor ground is not common with the device ground then the  $R_{GND}$  will produce a shift ( $I_{S(on)max} * R_{GND}$ ) in the input thresholds and the status output values. This shift will vary depending on how many devices are ON in the case of several high side drivers sharing the same  $R_{GND}$ .

If the calculated power dissipation leads to a large resistor or several devices have to share the same resistor then the ST suggests to utilize Solution 2 (see below).

**Solution 2:** A diode ( $D_{GND}$ ) in the ground line.

A resistor ( $R_{GND} = 1k\Omega$ ) should be inserted in parallel to  $D_{GND}$  if the device will be driving an inductive load.

This small signal diode can be safely shared amongst several different HSD. Also in this case, the presence of the ground network will produce a shift ( $\approx 600mV$ ) in the input threshold and the status output values if the microprocessor ground is not common with the device ground. This shift will not vary if more than one HSD shares the same diode/resistor network.

Series resistor in INPUT line is also required to prevent that, during battery voltage transient, the current exceeds the Absolute Maximum Rating.

Safest configuration for unused INPUT pin is to leave it unconnected, while unused SENSE pin has to be connected to Ground pin.

**LOAD DUMP PROTECTION**

$D_{Id}$  is necessary (Voltage Transient Suppressor) if the load dump peak voltage exceeds  $V_{CC}$  max DC rating. The same applies if the device will be subject to transients on the  $V_{CC}$  line that are greater than the ones shown in the ISO T/R 7637/1 table.

**µC I/Os PROTECTION:**

If a ground protection network is used and negative transients are present on the  $V_{CC}$  line, the control pins will be pulled negative. ST suggests to insert a resistor ( $R_{prot}$ ) in line to prevent the µC I/Os pins to latch-up.

The value of these resistors is a compromise between the leakage current of µC and the current required by the HSD I/Os (Input levels compatibility) with the latch-up limit of µC I/Os.

$$-V_{CCpeak} / I_{latchup} \leq R_{prot} \leq (V_{OHµC} - V_{IH} - V_{GND}) / I_{IHmax}$$

Calculation example:

For  $V_{CCpeak} = -100V$  and  $I_{latchup} \geq 20mA$ ;  $V_{OHµC} \geq 4.5V$   
 $5k\Omega \leq R_{prot} \leq 65k\Omega$ .

Recommended  $R_{prot}$  value is 10kΩ.



Off State Output Current

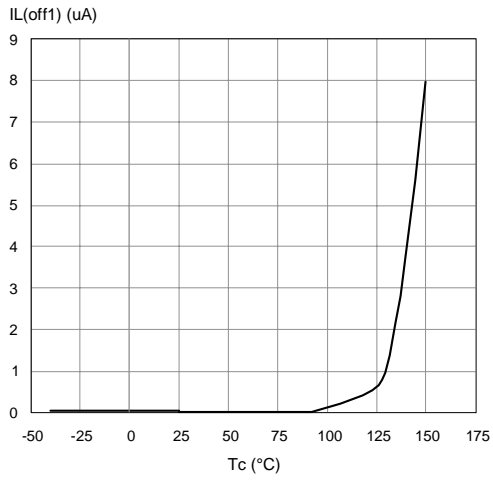

High Level Input Current

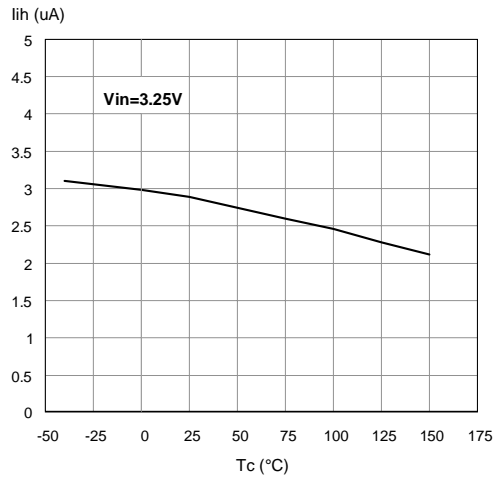

Input Clamp Voltage

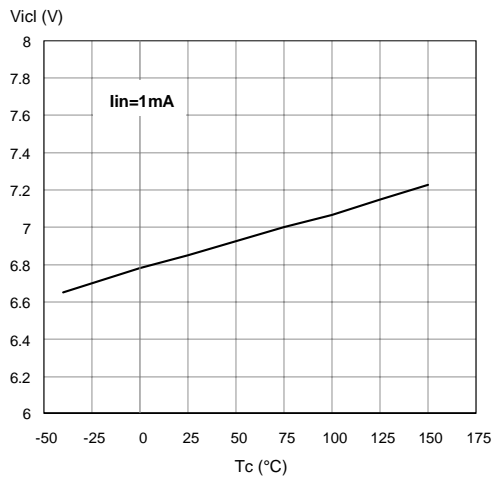

Input High Level

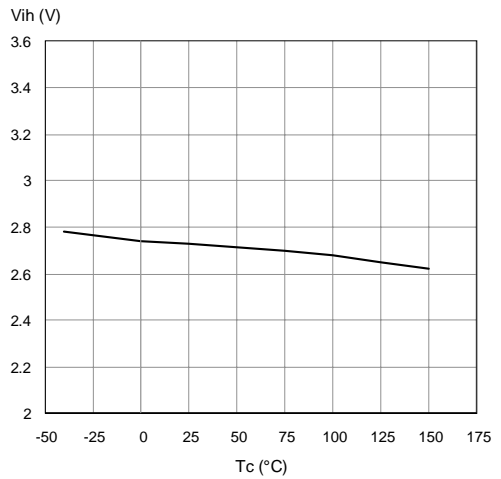

Input Low Level

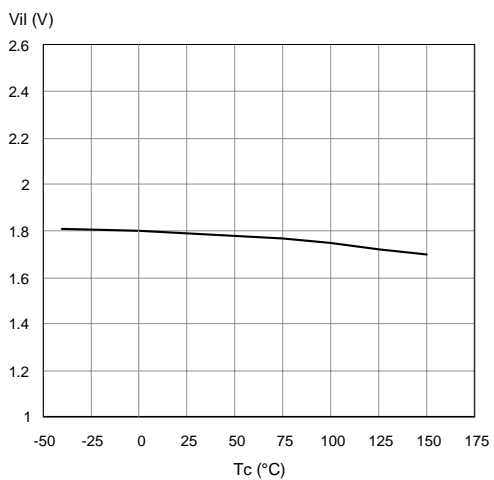

Input Hysteresis Voltage

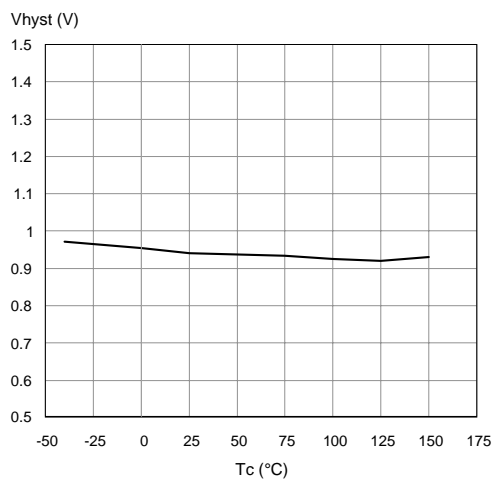

Overvoltage Shutdown

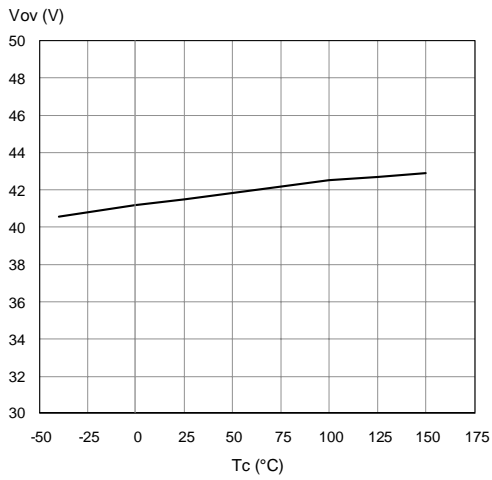

I<sub>LIM</sub> Vs T<sub>case</sub>

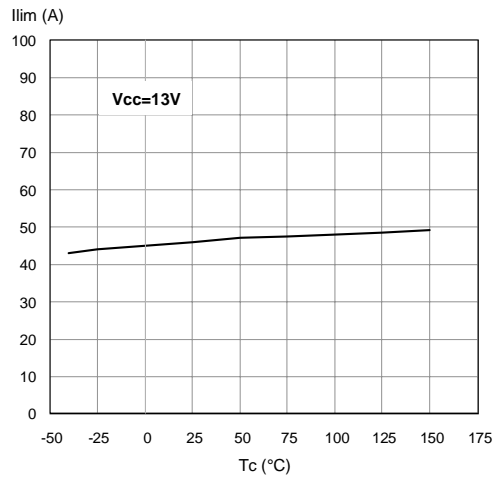

Turn-on Voltage Slope

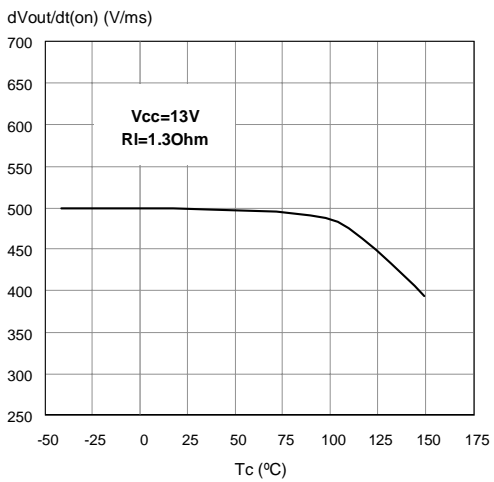

Turn-off Voltage Slope

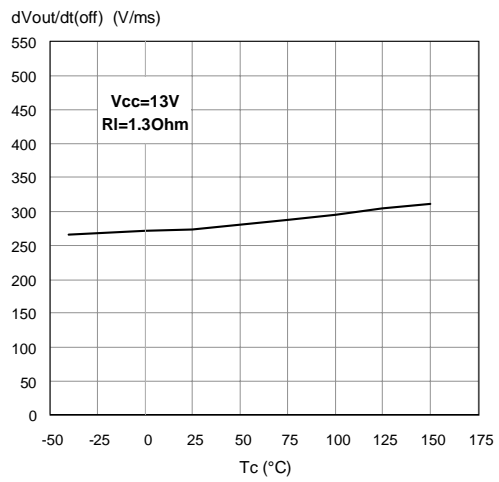

On State Resistance Vs T<sub>case</sub>

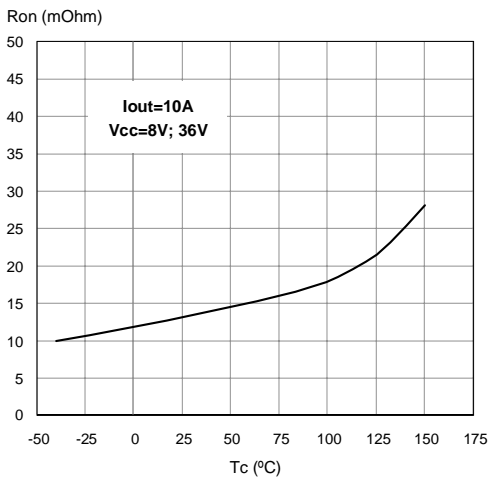

On State Resistance Vs V<sub>CC</sub>

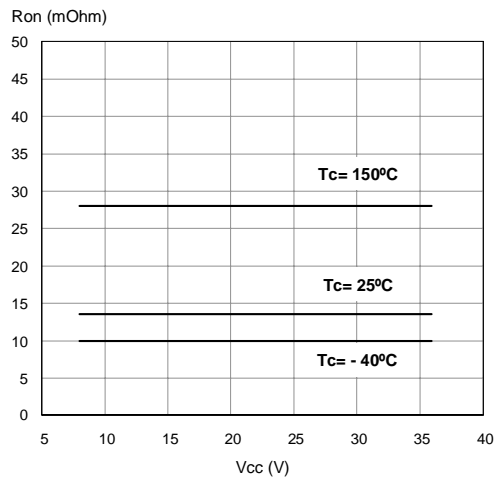

SO-16L Maximum turn off current versus load inductance

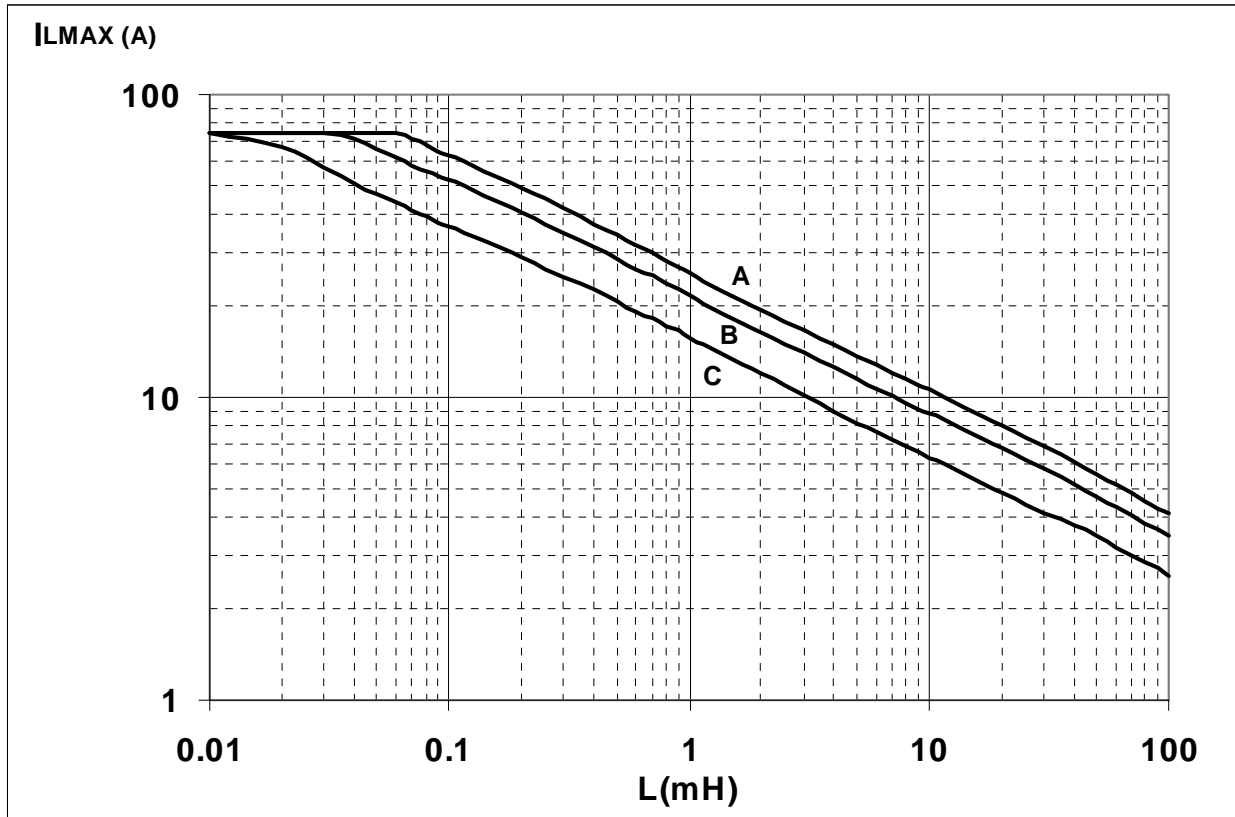

- A = Single Pulse at  $T_{jstart}=150^{\circ}C$
- B= Repetitive pulse at  $T_{jstart}=100^{\circ}C$
- C= Repetitive Pulse at  $T_{jstart}=125^{\circ}C$

Conditions:

$V_{CC}=13.5V$

Values are generated with  $R_L=0\Omega$

In case of repetitive pulses,  $T_{jstart}$  (at beginning of each demagnetization) of every pulse must not exceed the temperature specified above for curves B and C.

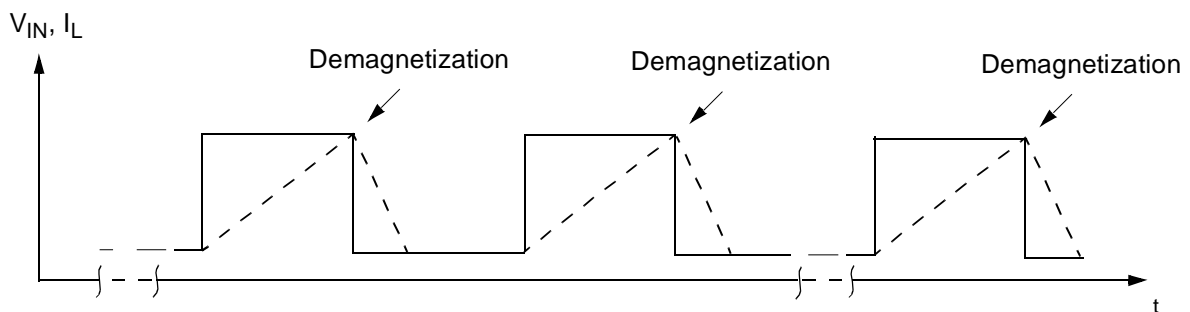

P<sup>2</sup>PAK Maximum turn off current versus load inductance

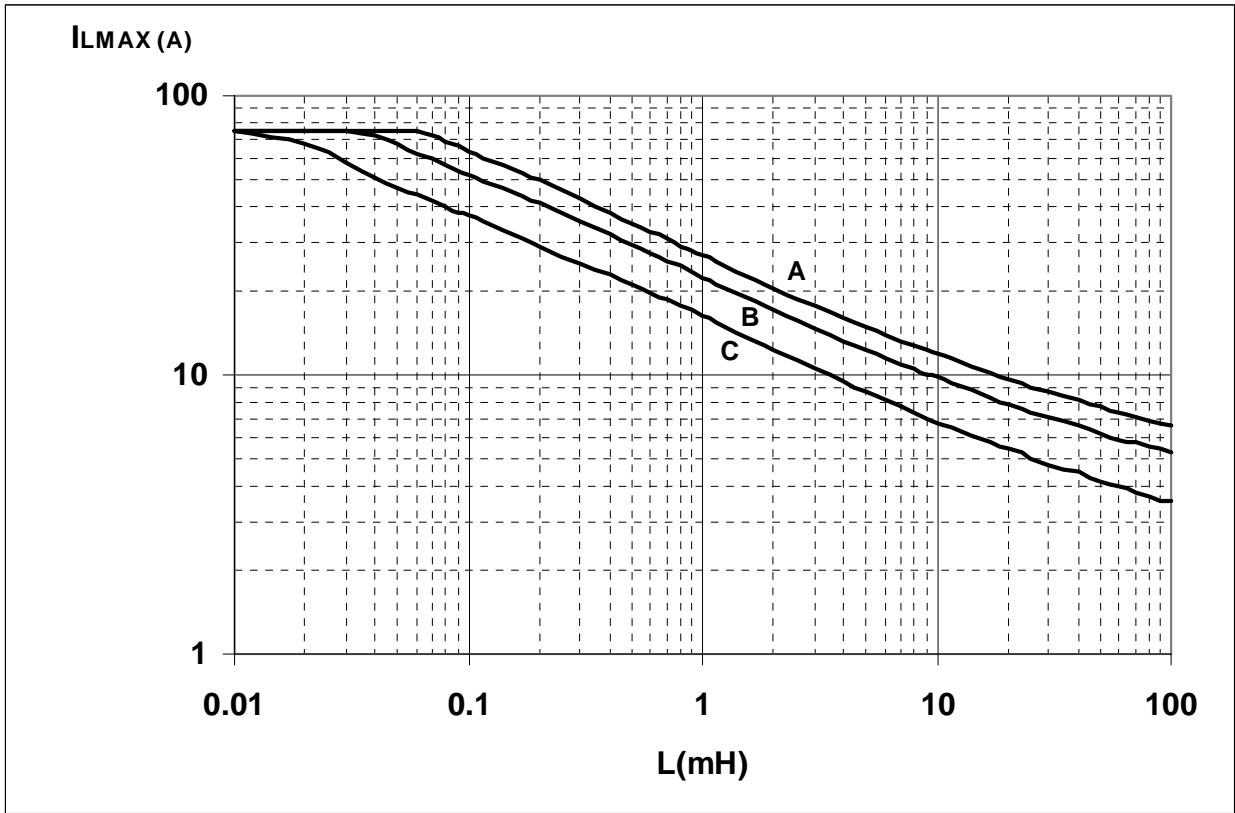

- A = Single Pulse at  $T_{jstart} = 150^\circ\text{C}$
- B = Repetitive pulse at  $T_{jstart} = 100^\circ\text{C}$
- C = Repetitive Pulse at  $T_{jstart} = 125^\circ\text{C}$

Conditions:

$V_{CC} = 13.5\text{V}$

Values are generated with  $R_L = 0\Omega$

In case of repetitive pulses,  $T_{jstart}$  (at beginning of each demagnetization) of every pulse must not exceed the temperature specified above for curves B and C.

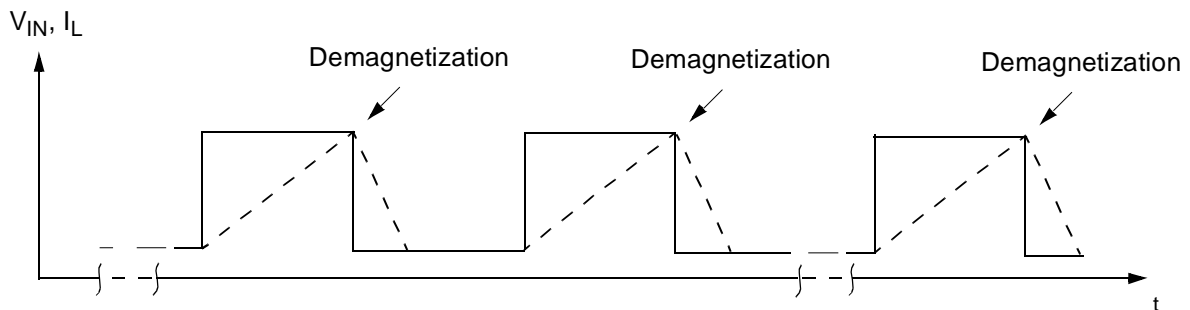

**P<sup>2</sup>PAK THERMAL DATA**

**P<sup>2</sup>PAK PC Board**

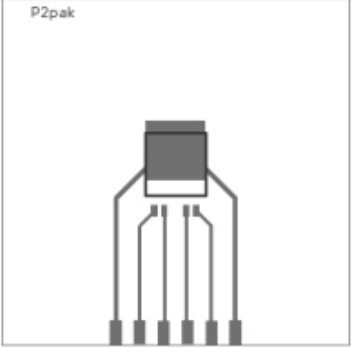

P2pak

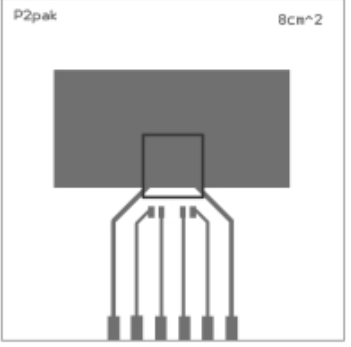

P2pak 8cm<sup>2</sup>

Layout condition of R<sub>th</sub> and Z<sub>th</sub> measurements (PCB FR4 area= 60mm x 60mm, PCB thickness=2mm, Cu thickness=35μm, Copper areas: 0.97cm<sup>2</sup>, 8cm<sup>2</sup>).

**R<sub>thj-amb</sub> Vs PCB copper area in open box free air condition**

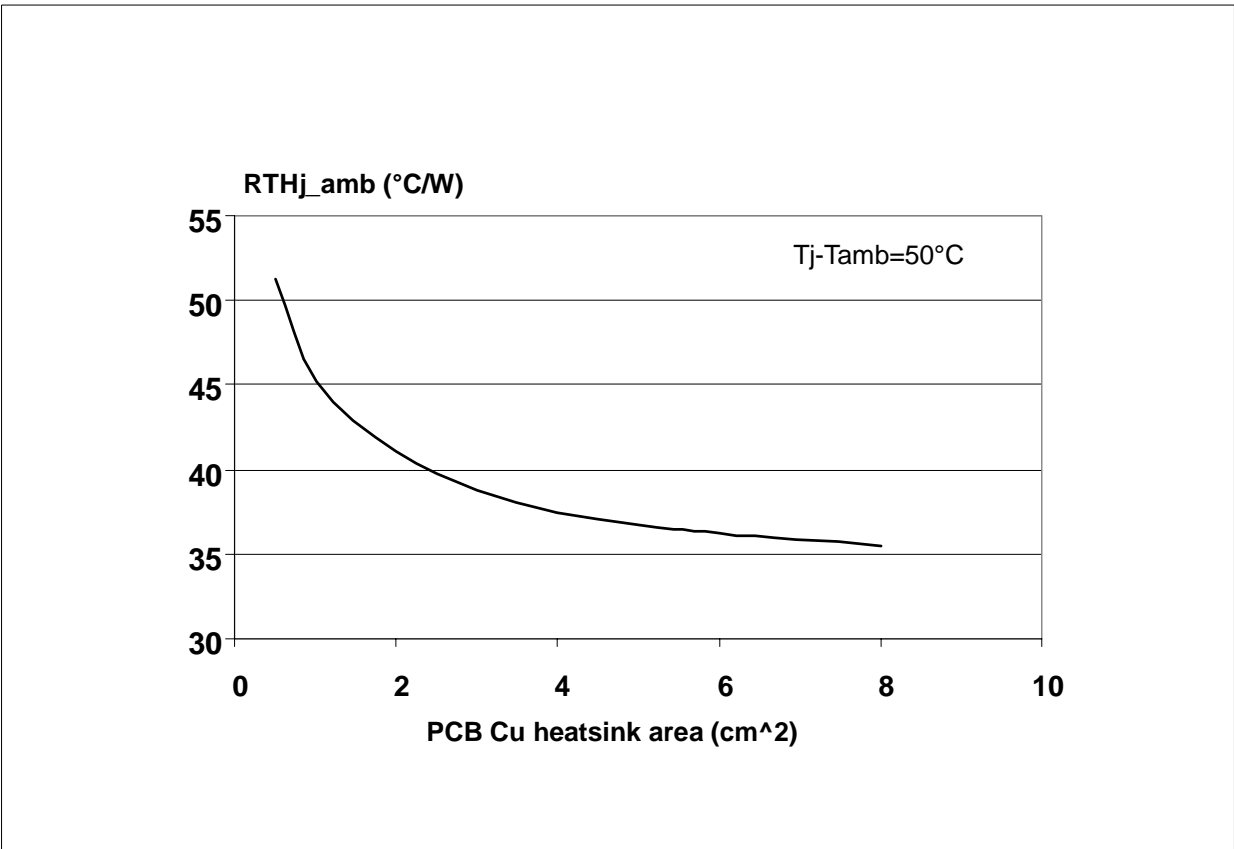

**SO-16L THERMAL DATA**

**SO-16L PC Board**

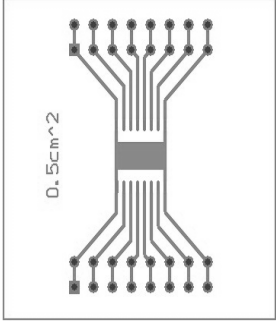
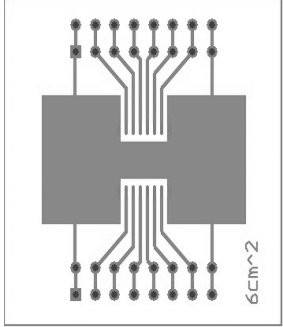

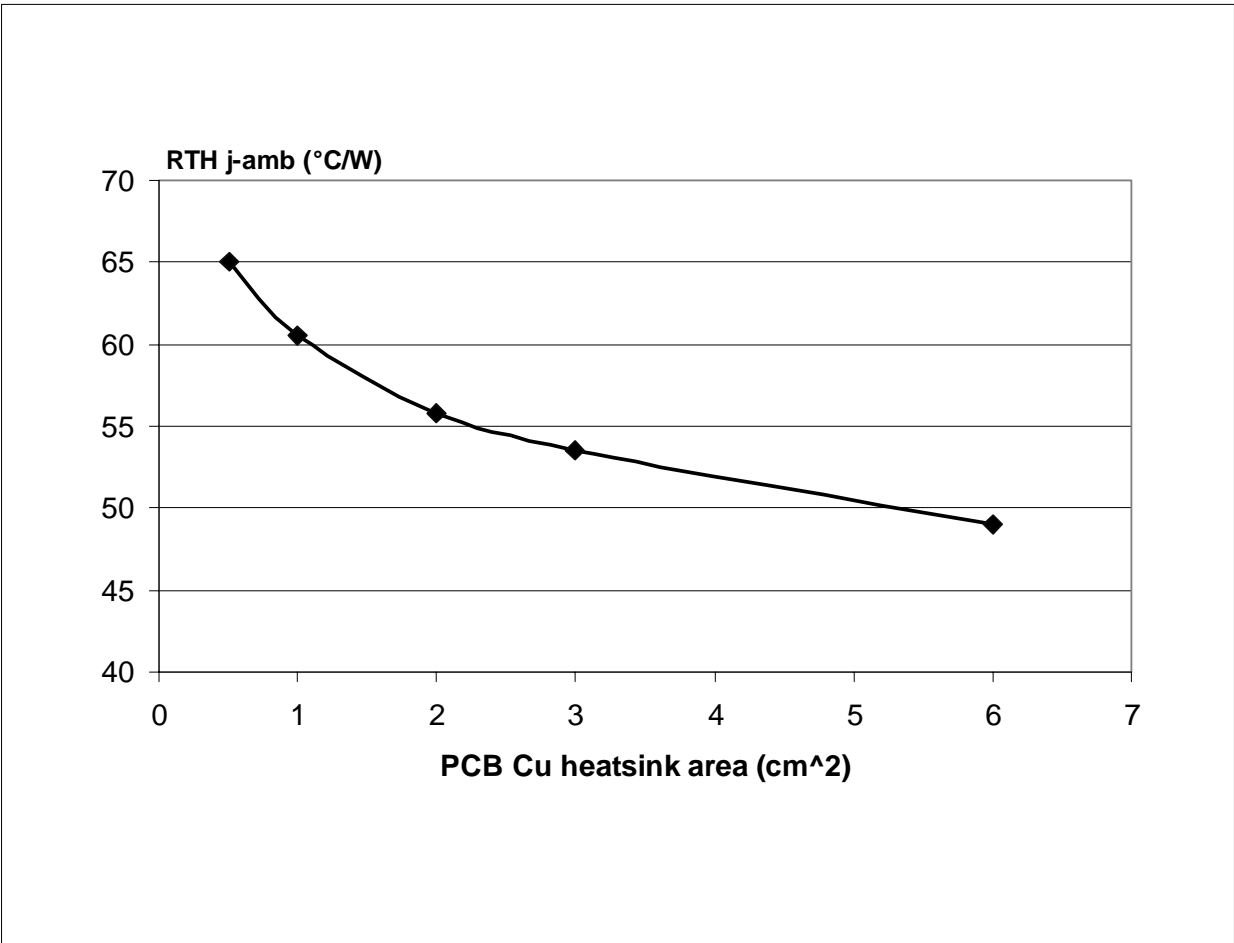

Layout condition of  $R_{th}$  and  $Z_{th}$  measurements (PCB FR4 area= 41mm x 48mm, PCB thickness=2mm, Cu thickness=35 $\mu$ m, Copper areas: 0.5cm<sup>2</sup>, 6cm<sup>2</sup>).

**$R_{thj-amb}$  Vs PCB copper area in open box free air condition**

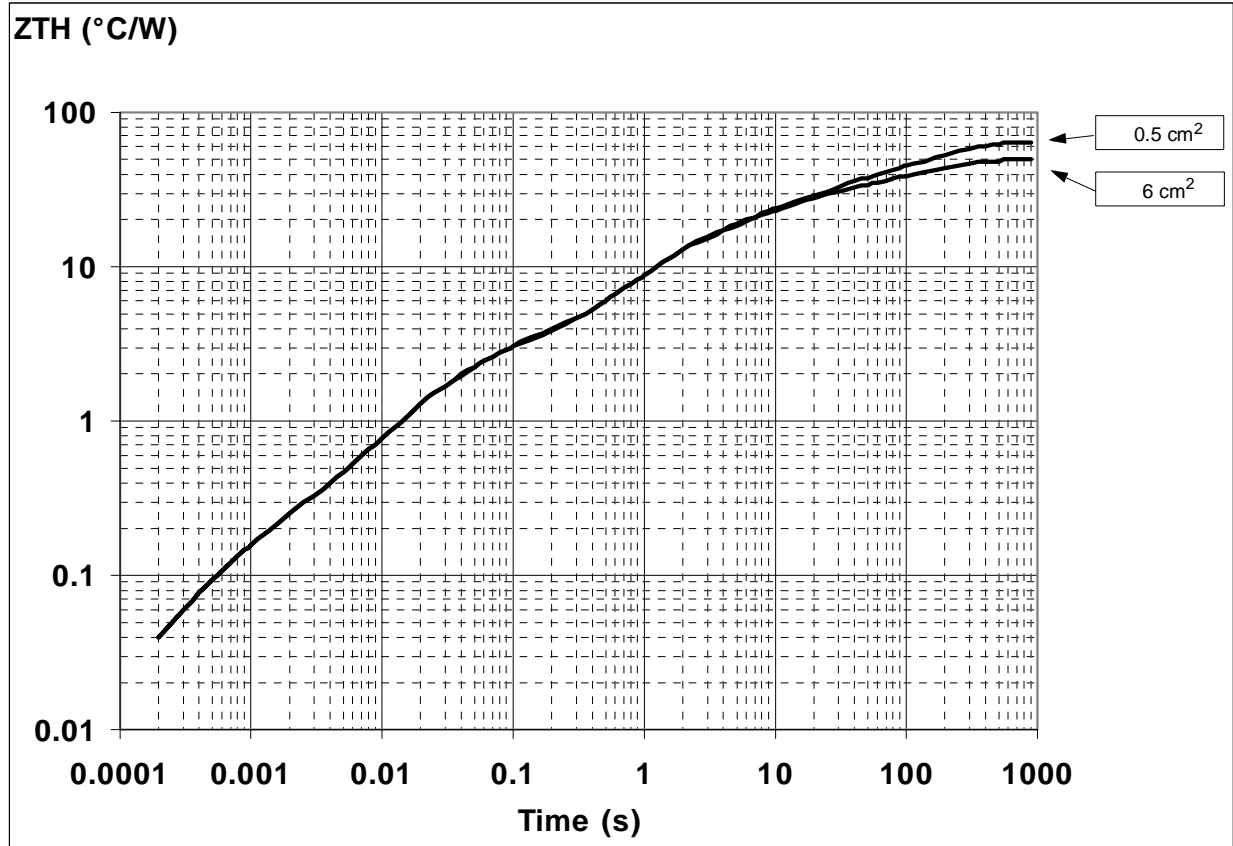

SO-16L Thermal Impedance Junction Ambient Single Pulse



Thermal fitting model of a single channel HSD in SO-16L

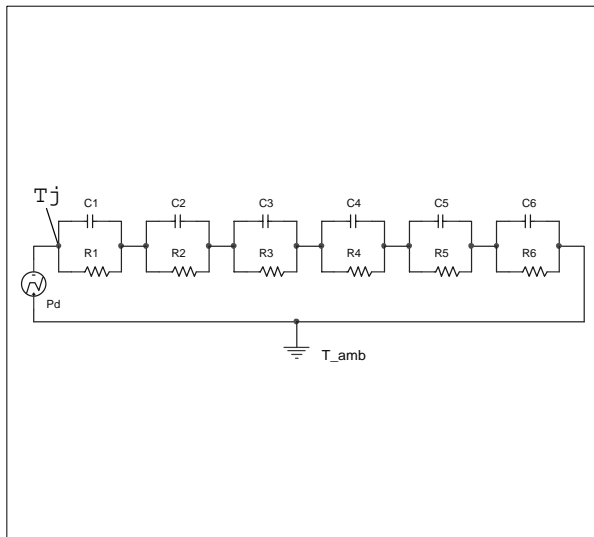

Pulse calculation formula

$$Z_{TH\delta} = R_{TH} \cdot \delta + Z_{THtp}(1 - \delta)$$

where  $\delta = t_p/T$

Thermal Parameter

Area/island (cm <sup>2</sup> )	0.5	6
R1 (°C/W)	0.02	
R2 (°C/W)	0.1	
R3 (°C/W)	2.2	
R4 (°C/W)	12	
R5 (°C/W)	15	
R6 (°C/W)	35	20
C1 (W.s/°C)	0.0015	
C2 (W.s/°C)	7.00E-03	
C3 (W.s/°C)	1.50E-02	
C4 (W.s/°C)	0.14	
C5 (W.s/°C)	1	
C6 (W.s/°C)	5	8



P<sup>2</sup>PAK Thermal Impedance Junction Ambient Single Pulse

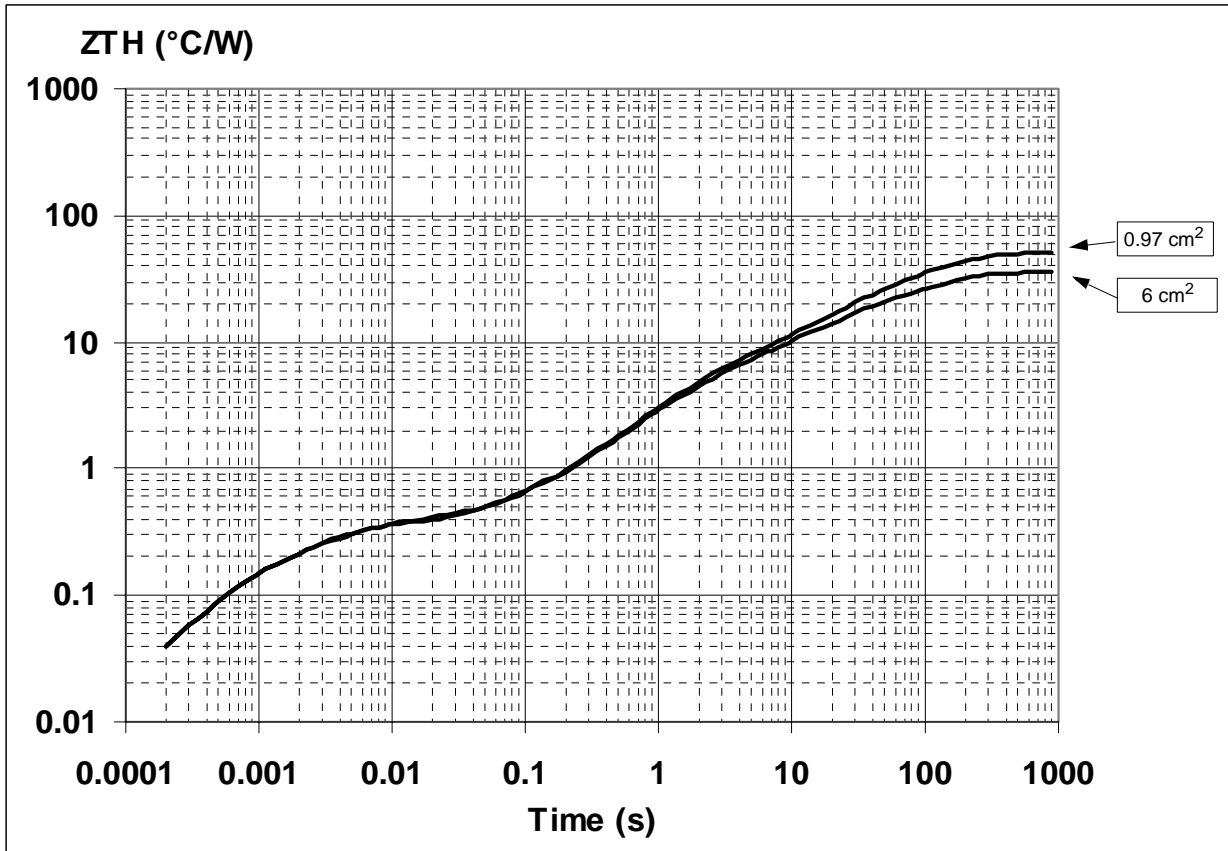

Thermal fitting model of a single channel HSD in P<sup>2</sup>PAK

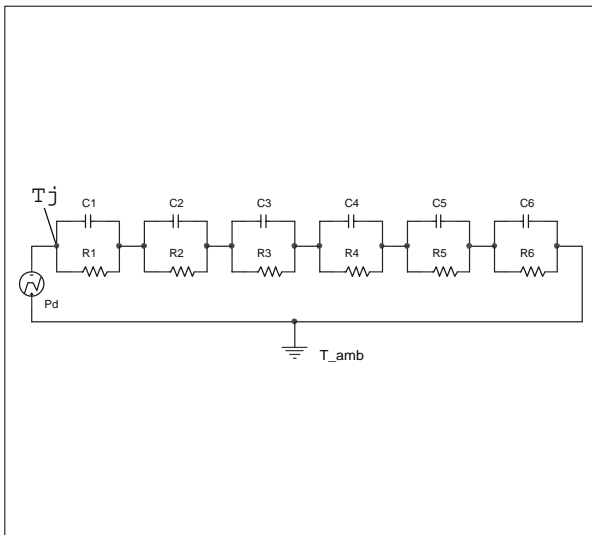

Pulse calculation formula

$$Z_{TH\delta} = R_{TH} \cdot \delta + Z_{THtp}(1 - \delta)$$

where  $\delta = t_p/T$

Thermal Parameter

Area/island (cm <sup>2</sup> )	0.97	6
R1 (°C/W)	0.02	
R2 (°C/W)	0.1	
R3 (°C/W)	0.22	
R4 (°C/W)	4	
R5 (°C/W)	9	
R6 (°C/W)	37	22
C1 (W.s/°C)	0.0015	
C2 (W.s/°C)	0.007	
C3 (W.s/°C)	0.015	
C4 (W.s/°C)	0.4	
C5 (W.s/°C)	2	
C6 (W.s/°C)	3	5

**SO-16L MECHANICAL DATA**

DIM.	mm.			inch		
	MIN.	TYP	MAX.	MIN.	TYP.	MAX.
A			2.65			0.104
a1	0.1		0.2	0.004		0.008
a2			2.45			0.096
b	0.35		0.49	0.014		0.019
b1	0.23		0.32	0.009		0.012
C		0.5			0.020	
c1	45° (typ.)					
D	10.1		10.5	0.397		0.413
E	10.0		10.65	0.393		0.419
e		1.27			0.050	
e3		8.89			0.350	
F	7.4		7.6	0.291		0.300
L	0.5		1.27	0.020		0.050
M			0.75			0.029
S	8° (max.)					

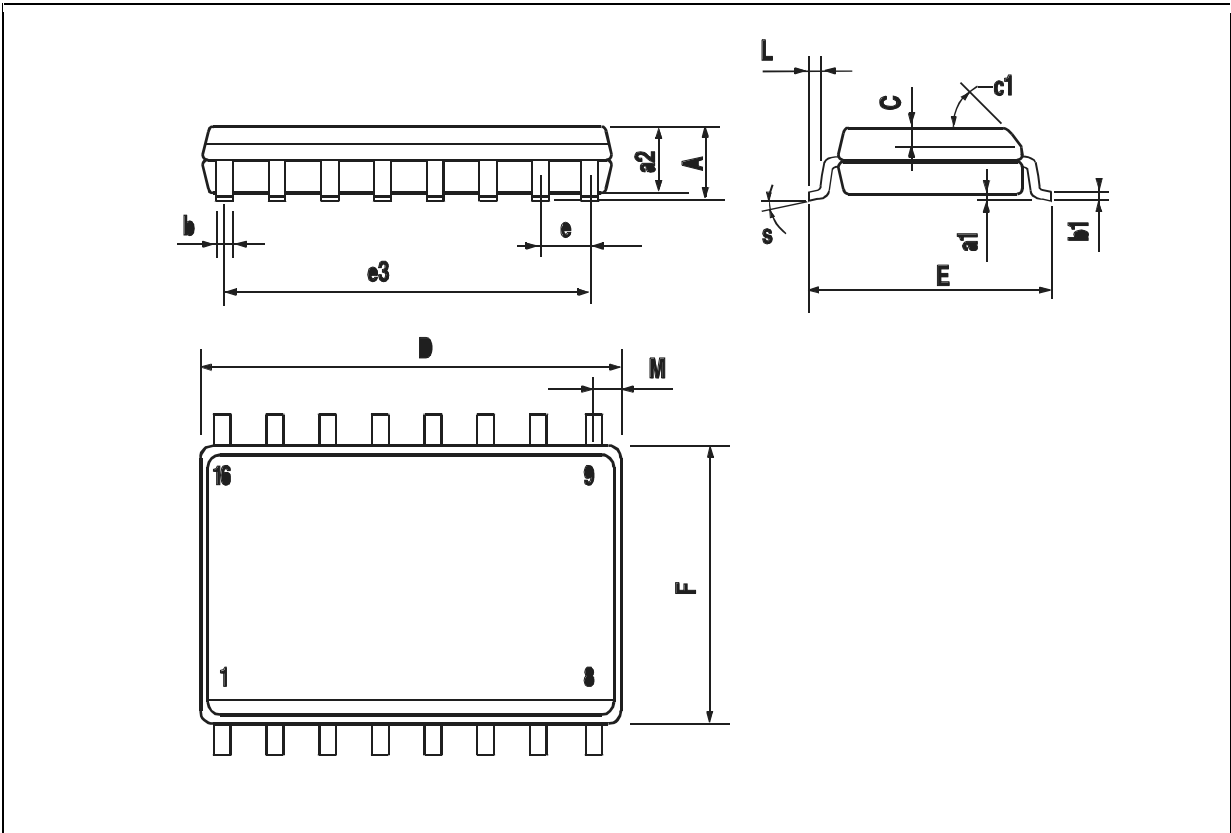

**PENTAWATT (VERTICAL) MECHANICAL DATA**

DIM.	mm.			inch		
	MIN.	TYP	MAX.	MIN.	TYP.	MAX.
A			4.8			0.189
C			1.37			0.054
D	2.4		2.8	0.094		0.110
D1	1.2		1.35	0.047		0.053
E	0.35		0.55	0.014		0.022
F	0.8		1.05	0.031		0.041
F1	1		1.4	0.039		0.055
G	3.2	3.4	3.6	0.126	0.134	0.142
G1	6.6	6.8	7	0.260	0.268	0.276
H2			10.4			0.409
H3	10.05		10.4	0.396		0.409
L		17.85			0.703	
L1		15.75			0.620	
L2		21.4			0.843	
L3		22.5			0.886	
L5	2.6		3	0.102		0.118
L6	15.1		15.8	0.594		0.622
L7	6		6.6	0.236		0.260
M		4.5			0.177	
M1		4			0.157	
Diam.	3.65		3.85	0.144		0.152

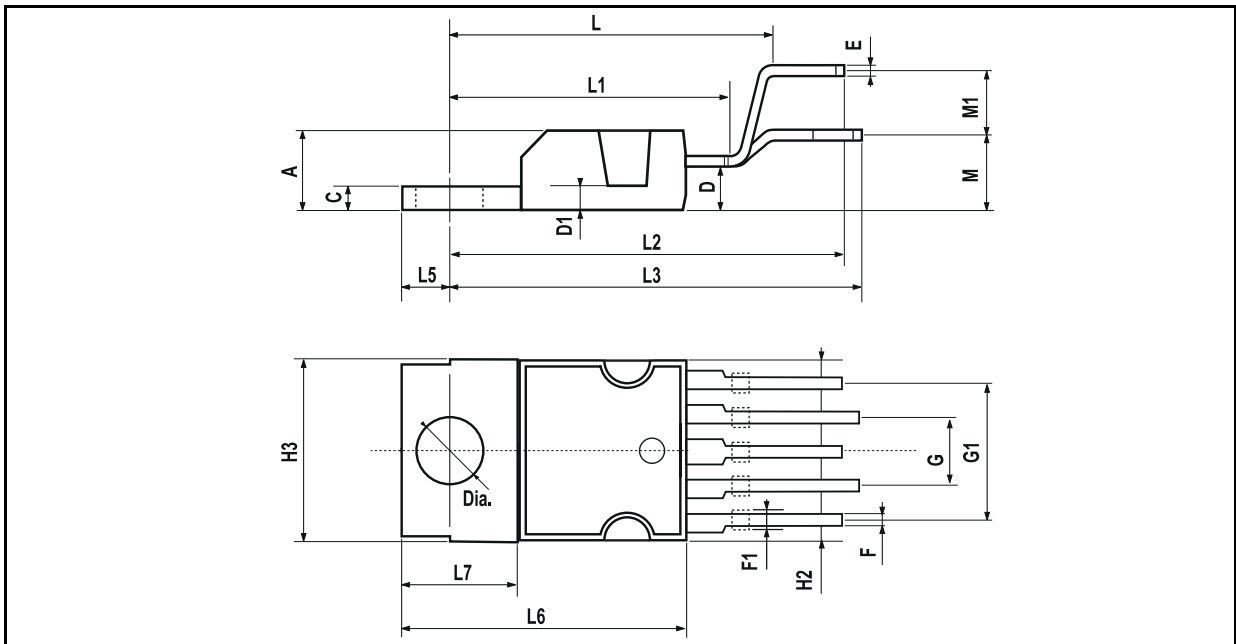

## P<sup>2</sup>PAK MECHANICAL DATA

DIM.	mm.		
	MIN.	TYP	MAX.
A	4.30		4.80
A1	2.40		2.80
A2	0.03		0.23
b	0.80		1.05
c	0.45		0.60
c2	1.17		1.37
D	8.95		9.35
D2		8.00	
E	10.00		10.40
E1		8.50	
e	3.20		3.60
e1	6.60		7.00
L	13.70		14.50
L2	1.25		1.40
L3	0.90		1.70
L5	1.55		2.40
R		0.40	
V2	0°		8°
Package Weight	1.40 Gr (typ)		

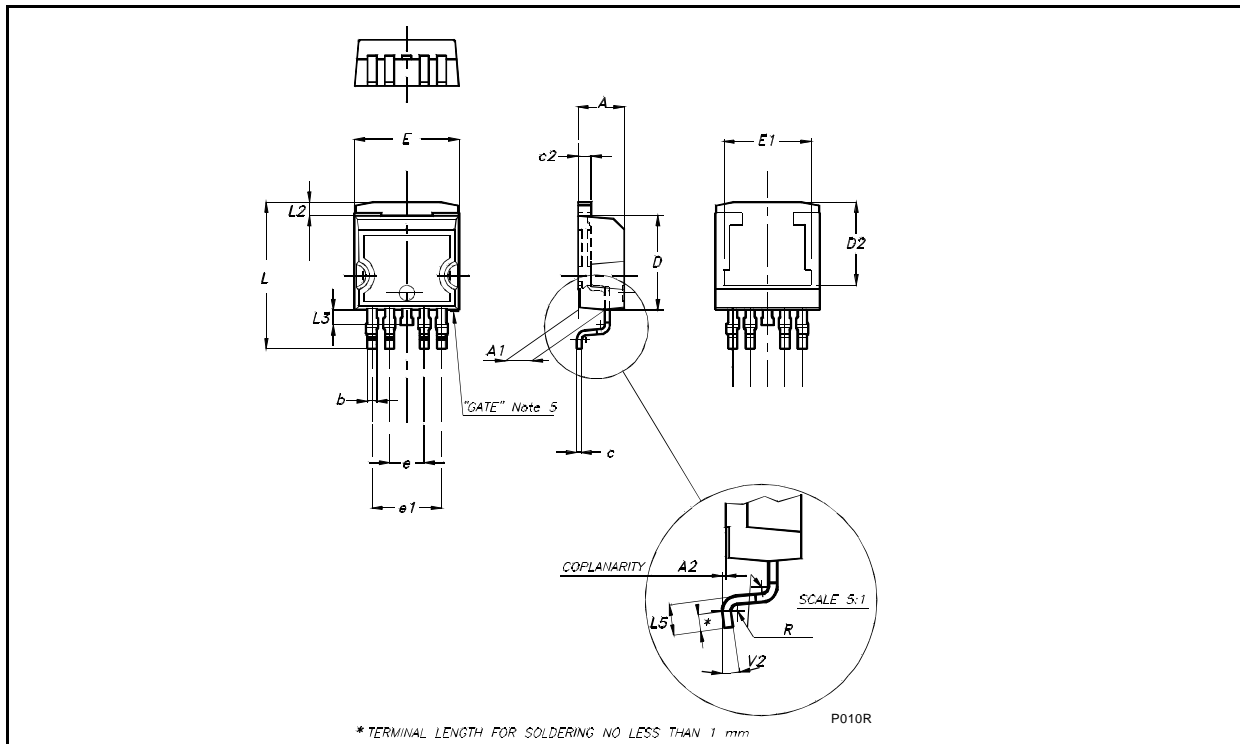

**SO-16L TUBE SHIPMENT (no suffix)**

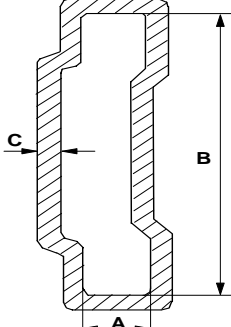

<b>Base Q.ty</b>	50
<b>Bulk Q.ty</b>	1000
<b>Tube length (<math>\pm 0.5</math>)</b>	532
<b>A</b>	3.5
<b>B</b>	13.8
<b>C (<math>\pm 0.1</math>)</b>	0.6

All dimensions are in mm.

**TAPE AND REEL SHIPMENT (suffix "13TR")**

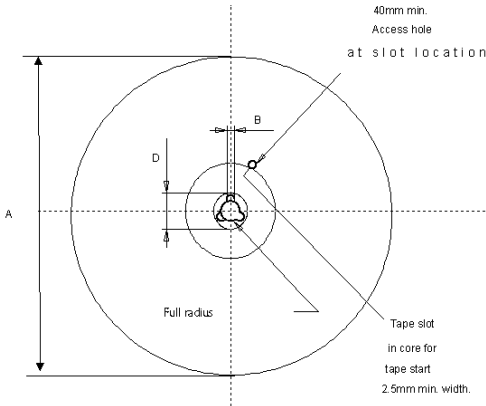

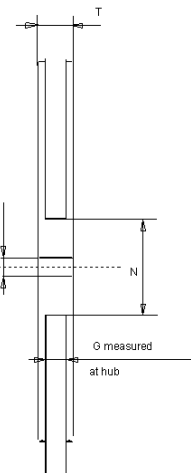

**REEL DIMENSIONS**

<b>Base Q.ty</b>	1000
<b>Bulk Q.ty</b>	1000
<b>A (max)</b>	330
<b>B (min)</b>	1.5
<b>C (<math>\pm 0.2</math>)</b>	13
<b>F</b>	20.2
<b>G (+ 2 / -0)</b>	16.4
<b>N (min)</b>	60
<b>T (max)</b>	22.4

**TAPE DIMENSIONS**  
According to Electronic Industries Association (EIA) Standard 481 rev. A, Feb 1986

<b>Tape width</b>	<b>W</b>	16
<b>Tape Hole Spacing</b>	<b>P0 (<math>\pm 0.1</math>)</b>	4
<b>Component Spacing</b>	<b>P</b>	12
<b>Hole Diameter</b>	<b>D (<math>\pm 0.1/-0</math>)</b>	1.5
<b>Hole Diameter</b>	<b>D1 (min)</b>	1.5
<b>Hole Position</b>	<b>F (<math>\pm 0.05</math>)</b>	7.5
<b>Compartment Depth</b>	<b>K (max)</b>	6.5
<b>Hole Spacing</b>	<b>P1 (<math>\pm 0.1</math>)</b>	2

All dimensions are in mm.

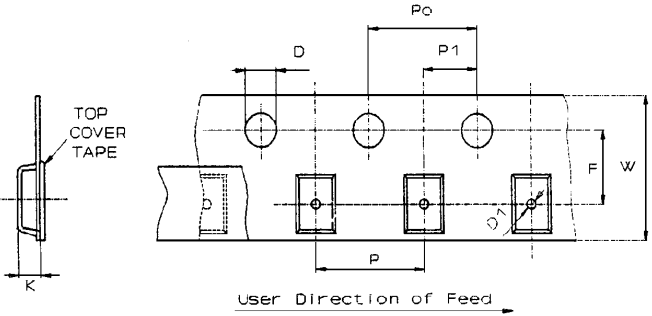

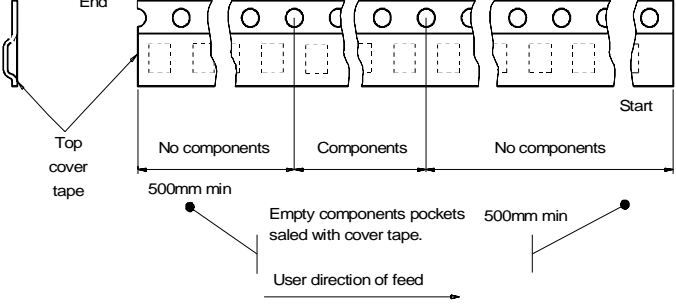

**PENTAWATT TUBE SHIPMENT (no suffix)**

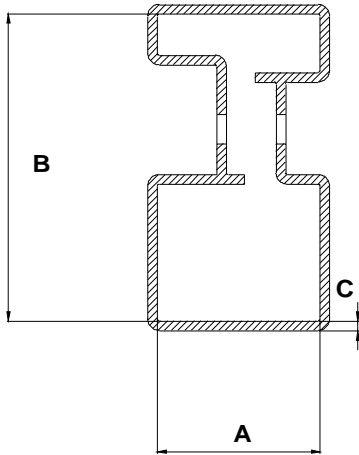

<b>Base Q.ty</b>	50
<b>Bulk Q.ty</b>	1000
<b>Tube length (<math>\pm 0.5</math>)</b>	532
<b>A</b>	18
<b>B</b>	33.1
<b>C (<math>\pm 0.1</math>)</b>	1

All dimensions are in mm.

**P<sup>2</sup>PAK TUBE SHIPMENT (no suffix)**

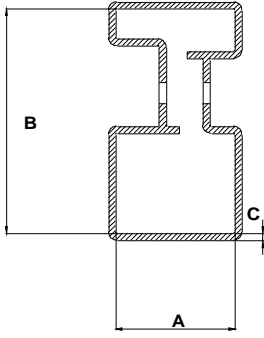

<b>Base Q.ty</b>	50
<b>Bulk Q.ty</b>	1000
<b>Tube length (± 0.5)</b>	532
<b>A</b>	18
<b>B</b>	33.1
<b>C (± 0.1)</b>	1

All dimensions are in mm.

**TAPE AND REEL SHIPMENT (suffix "13TR")**

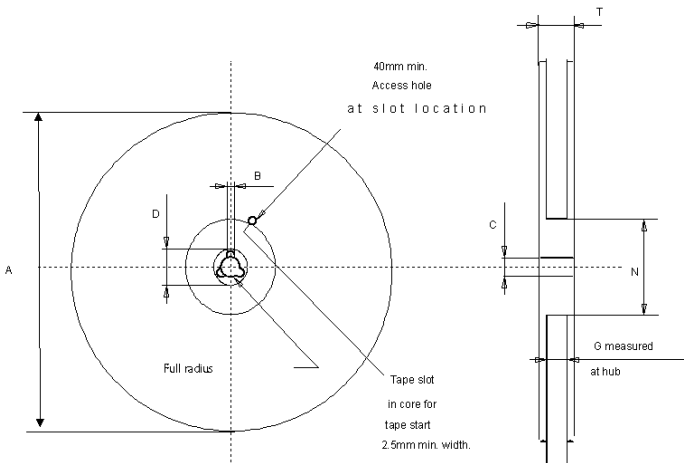

40mm min. Access hole at slot location

Full radius

Tape slot in core for tape start 2.5mm min. width.

G measured at hub

### REEL DIMENSIONS

<b>Base Q.ty</b>	1000
<b>Bulk Q.ty</b>	1000
<b>A (max)</b>	330
<b>B (min)</b>	1.5
<b>C (± 0.2)</b>	13
<b>F</b>	20.2
<b>G (+ 2 / -0)</b>	24.4
<b>N (min)</b>	60
<b>T (max)</b>	30.4

All dimensions are in mm.

**TAPE DIMENSIONS**

According to Electronic Industries Association (EIA) Standard 481 rev. A, Feb 1986

<b>Tape width</b>	<b>W</b>	24
<b>Tape Hole Spacing</b>	<b>P0 (± 0.1)</b>	4
<b>Component Spacing</b>	<b>P</b>	16
<b>Hole Diameter</b>	<b>D (± 0.1/-0)</b>	1.5
<b>Hole Diameter</b>	<b>D1 (min)</b>	1.5
<b>Hole Position</b>	<b>F (± 0.05)</b>	11.5
<b>Compartment Depth</b>	<b>K (max)</b>	6.5
<b>Hole Spacing</b>	<b>P1 (± 0.1)</b>	2

All dimensions are in mm.

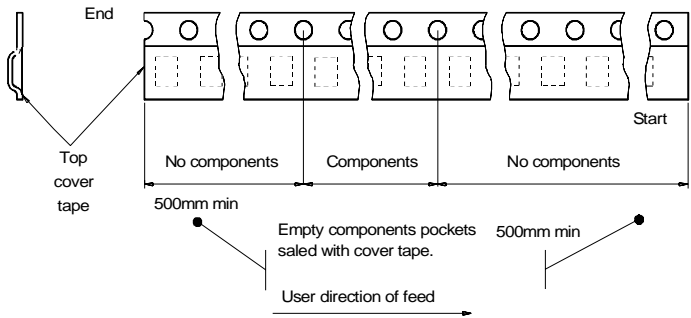
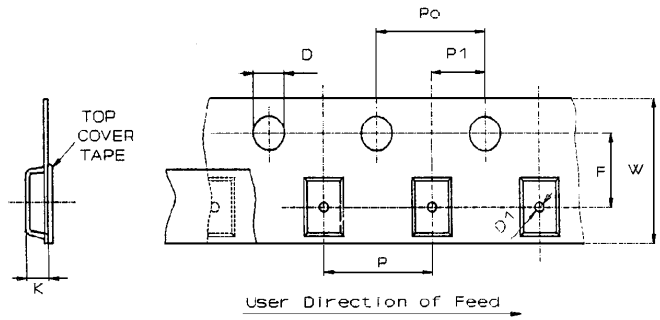
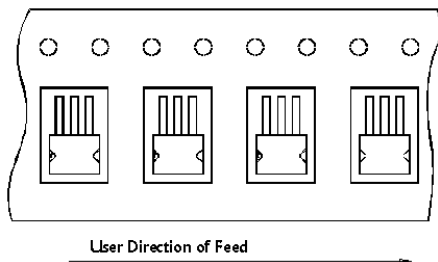

**REVISION HISTORY**

Date	Revision	Description of Changes
July 2004	1	<ul style="list-style-type: none"><li>- Current and voltage convention update (page 2).</li><li>- "Configuration diagram (top view) &amp; suggested connections for unused and n.c. pins" insertion (page 2).</li><li>- 6cm<sup>2</sup> Cu condition insertion in Thermal Data table (page 3).</li><li>- V<sub>CC</sub> - OUTPUT DIODE section update (page 5).</li><li>- PROTECTIONS note insertion (page 5).</li><li>- Revision History table insertion (page 24).</li><li>- Disclaimers update (page 25).</li></ul>
July 2004	2	<ul style="list-style-type: none"><li>- Suggested connections for unused and n.c.pins" correction (page 2).</li></ul>



Information furnished is believed to be accurate and reliable. However, STMicroelectronics assumes no responsibility for the consequences of use of such information nor for any infringement of patents or other rights of third parties which may result from its use. No license is granted by implication or otherwise under any patent or patent rights of STMicroelectronics. Specifications mentioned in this publication are subject to change without notice. This publication supersedes and replaces all information previously supplied. STMicroelectronics products are not authorized for use as critical components in life support devices or systems without express written approval of STMicroelectronics.

The ST logo is a trademark of STMicroelectronics.  
All other names are the property of their respective owners

© 2004 STMicroelectronics - Printed in ITALY- All Rights Reserved.

**STMicroelectronics GROUP OF COMPANIES**

Australia - Belgium - Brazil - Canada - China - Czech Republic - Finland - France - Germany - Hong Kong - India - Israel - Italy - Japan -  
Malaysia - Malta - Morocco - Singapore - Spain - Sweden - Switzerland - United Kingdom - United States  
<http://www.st.com>