

VIPer53E

STATE-OF-THE-ART PRIMARY SIDE SWITCH FOR AC/DC CONVERTERS

The new VIPer53E includes a PWM driver, an MDmesh MOSFET, a start-up high voltage current source and several on-chip protection circuits. The VIPer53E is an alternative choice to the VIPer53 when only the secondary regulation is required in a power supply. Like the standard VIPer53, the new version is housed in surface mounting DIP-8 and PowerSO-10 packages.

Extending The Device Supply Voltage

The higher V_{DD} voltage range brings flexibility in designing the transformer. In fact in secondary regulation VIPer53E V_{DD} voltage extends from 9V to 18V, while in the VIPer53 it goes from 9V to 14.5V and this wide voltage range can follow fast load variations. The extended V_{DD} is implemented by eliminating an internal error amplifier.

Why Use the VIPer53E?

Thanks to the MDmesh MOSFET with a breakdown voltage of 620V, an $R_{DS(on)}$ of 1Ω at 25°C and a typical handling output power of 40W for a 85 to 265Vac voltage mains. For this level of power the device does not require a heat-sink.

The total power consumption of the converter is less than 0.5W for the system when working in stand-by mode. This means power supply designers can easily meet the Blue Angel Eco or Energy Star Program.

Order Codes

P / N	Input Mains	
	195-265Vac	85-265Vac
VIPer53EDIP	50W	30W
VIPer53ESP	65W	40W

Applications

Although the main application of VIPer53E is in AC/DC converters for consumer equipment such as set-top boxes, DVDs, VCRs, it can also be used for stand-by power supplies for servers or in home appliances where a very efficient AC/DC power supply in buck topology is needed.



Features

- Automatic burst mode for very low consumption in stand-by conditions (less than 500mW);
- Integrated high voltage start-up current source;
- Overload and short circuit control;
- Over-voltage protection at 18V;
- Over-temperature shutdown;
- Under-voltage protection;
- Current mode control with adjustable drain current limitation;
- Externally set switching frequency, up to 300kHz.

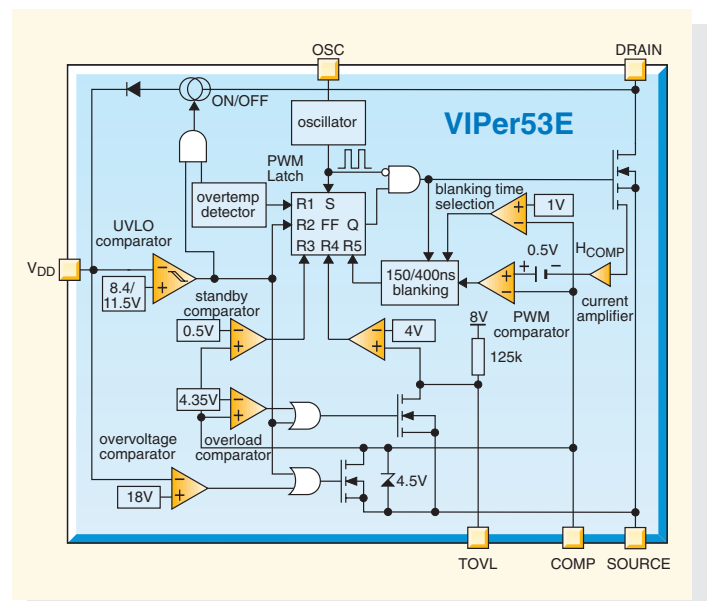

VIPer53E general block diagram