



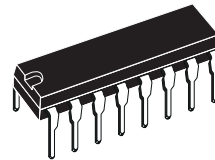
ULN2065B - ULN2067B  
 ULN2069B - ULN2071B  
 ULN2075B - ULN2077B

## 80 V - 1.5 A QUAD DARLINGTON SWITCHES

- OUTPUT CURRENT TO 1.5 A EACH DARLINGTON
- MINIMUM BREAKDOWN 80 V
- SUSTAINING VOLTAGE AT LEAST 50 V
- INTEGRAL SUPPRESSION DIODES (ULN2065B, ULN2067B, ULN2069B and ULN2071B)
- ISOLATED DARLINGTON PINOUT (ULN2075B and ULN2077B)
- VERSIONS COMPATIBLE WITH ALL POPULAR LOGIC FAMILIES

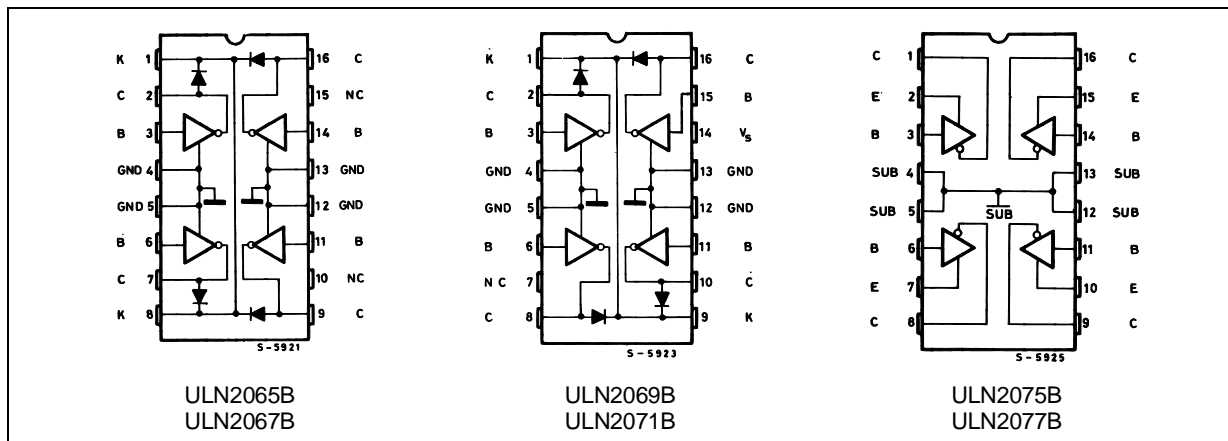
### DESCRIPTION

Designed to interface logic to a wide variety of high current, high voltage loads, these devices each contain four NPN darlington switches delivering up to 1.5 A with a specified minimum breakdown of 80 V and a sustaining voltage of 50 V. The ULN2065B, ULN2067B, ULN2069B and ULN2071B contain integral suppression diodes for inductive loads and have common emitters; the ULN2075B and ULN2077B feature isolated darlington pinouts and are intended for applications such as emitter follower configurations. Inputs of the ULN2065B, ULN2069B and ULN2075B are compatible with popular 5 V logic families and the ULN2067B, ULN2071B and ULN2077B are compatible with 6-15 VCMOS and PMOS. The ULN2069B and ULN2071B include a predriver stage to provide extragrain, reducing the load on control logic.



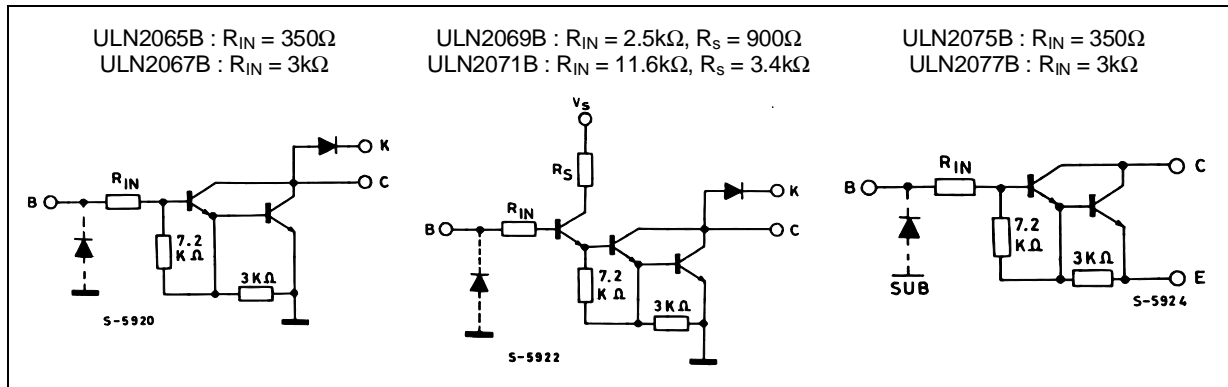
POWERDIP  
 12 + 2 + 2

### PIN CONNECTIONS AND ORDER CODES



# ULN2065B-ULN2067B-ULN2069B-ULN2071B-ULN2075B-ULN2077B

## SCHEMATIC DIAGRAM



## ABSOLUTE MAXIMUM RATINGS

Symbol	Parameter	Value	Unit	
$V_{CEX}$	Output Voltage	80	V	
$V_{CE(sus)}$	Output Sustaining Voltage	50	V	
$I_O$	Output Current	1.75	A	
$V_i$	Input Voltage	for ULN2075B – 2077B	60	V
		for ULN2067B – 2071B	30	V
		for ULN2065B – 2069B	15	V
$I_i$	Input Current	25	mA	
$V_s$	Supply Voltage	for ULN2069B	10	V
		for ULN2071B	20	V
$P_{tot}$	Power Dissipation	at $T_{pins} = 90^\circ C$	4.3	W
		at $T_{amb} = 70^\circ C$	1	W
$T_{amb}$	Operating Ambient Temperature Range	- 20 to 85	$^\circ C$	
$T_{stg}$	Storage Temperature	- 55 to 150	$^\circ C$	

## ELECTRICAL CHARACTERISTICS ( $T_{amb} = 25^\circ C$ unless otherwise specified )

Symbol	Parameter	Test Conditions	Min.	Typ.	Max.	Unit	Fig.
$I_{CEX}$	Output Leakage Current	$V_{CE} = 80V$ $T_{amb} = 25^\circ C$ $T_{amb} = 70^\circ C$			100 500	$\mu A$ $\mu A$	1
$V_{CE(sus)}$	Collector-emitter Sustaining Voltage	$I_C = 100mA$ , $V_i = 0.4V$	50			V	2
$V_{CE(sat)}$	Collector-emitter Saturation Voltage	$I_C = 500mA$ $I_B = 625\mu A$			1.1	V	3
		$I_C = 750mA$ $I_B = 935\mu A$			1.2	V	3
		$I_C = 1A$ $I_B = 1.25mA$			1.3	V	3
		$I_C = 1.25A$ $I_B = 2mA$			1.4	V	3
		$I_C = 1.5A$ $I_B = 2.25mA$			1.5	V	3
$I_{i(on)}$	Input Current	for ULN2065B and ULN2075B					
		$V_i = 2.4V$	1.4		4.3	mA	4
		$V_i = 3.75V$	3.3		9.6	mA	4
		for ULN2067B and ULN2077B					
		$V_i = 5V$	0.6		1.8	mA	4
		$V_i = 12V$	1.7		5.2	mA	4
		for ULN2069B					
		$V_i = 2.75V$			5.5	mA	4
		$V_i = 3.75V$			10	mA	4
		for ULN2071B					
$V_i = 5V$			4	mA	4		
$V_i = 12V$			12.5	mA	4		

**ULN2065B-ULN2067B-ULN2069B-ULN2071B-ULN2075B-ULN2077B**

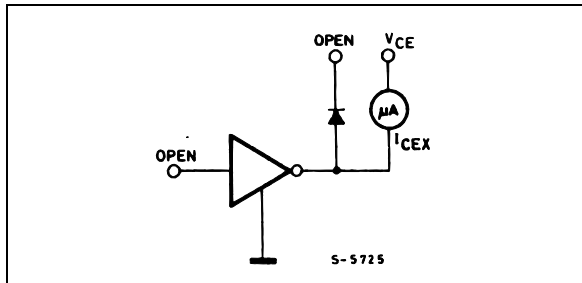
**ELECTRICAL CHARACTERISTICS** ( $T_{amb} = 25^{\circ}C$  unless otherwise specified ) (continued)

Symbol	Parameter	Test Conditions	Min.	Typ.	Max.	Unit	Fig.
$V_{i(on)}$	Input Voltage	$V_{CE} = 2V, I_C = 1A$ ULN2065B, ULN2075B ULN2067B, ULN2077B			2	V	5
					6.5	V	5
		$V_{CE} = 2V, I_C = 1.5A$ ULN2065B, ULN2075B ULN2067B, ULN2077B ULN2069B ULN2071B			2.5	V	5
					10	V	5
					2.75	V	5
					5	V	5
$I_s$	Supply Current	for ULN2069B $I_C = 500mA, V_i = 2.75V$			6	mA	8
		for ULN2071B $I_C = 500mA, V_i = 5V$			4.5	mA	8
$t_{PLH}$	Turn-on Delay Time	$0.5 V_i$ to $0.5 V_o$			1	$\mu s$	
$t_{PHL}$	Turn-off Delay Time	$0.5 V_i$ to $0.5 V_o$			1.5	$\mu s$	
$I_R$	Clamp Diode Leakage Current	for ULN2065B-ULN2067B and ULN2069B-ULN2071B $V_R = 80V$ $T_{amb} = 25^{\circ}C$ $T_{amb} = 70^{\circ}C$			50	$\mu A$	6
					100	$\mu A$	
$V_F$	Clamp Diode Forward Voltage	for ULN2065B-ULN2067B and ULN2069B-ULN2071B $I_F = 1A$ $I_F = 1.5A$			1.75 2	V V	7

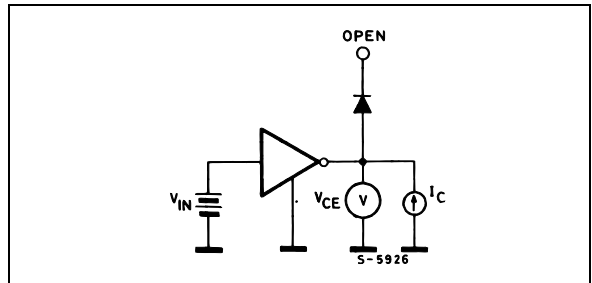
- Notes :** 1. Input voltage is with reference to the substrate (no connection to any other pins) for the ULN2075B and ULN2077B reference is ground for all other types.  
2. Input current may be limited by maximum allowable input voltage.

**TEST CIRCUITS**

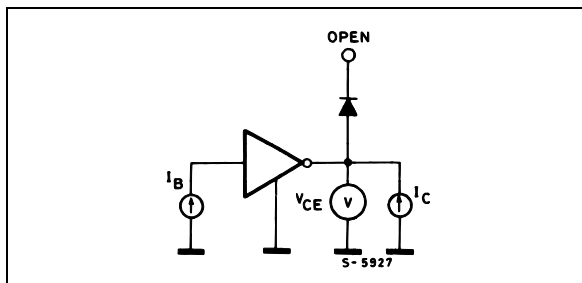
**Figure 1.**



**Figure 2.**



**Figure 3.**



**Figure 4.**

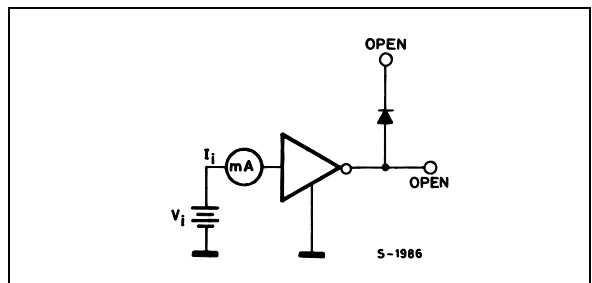


Figure 5.

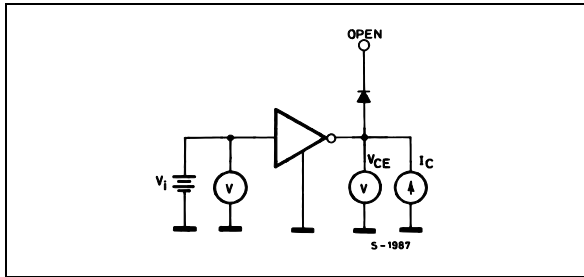


Figure 6.

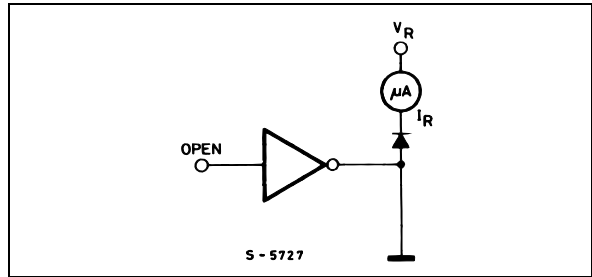


Figure 7.

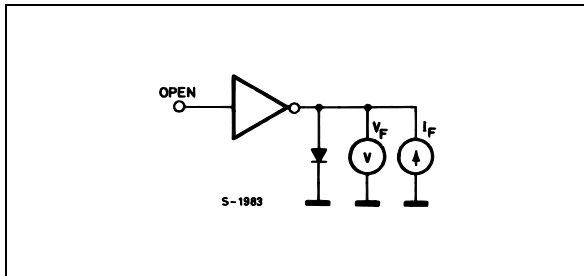


Figure 8.

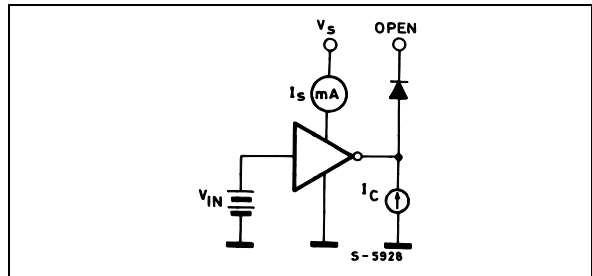


Figure 9 : Input Current as a Function of Input Voltage.

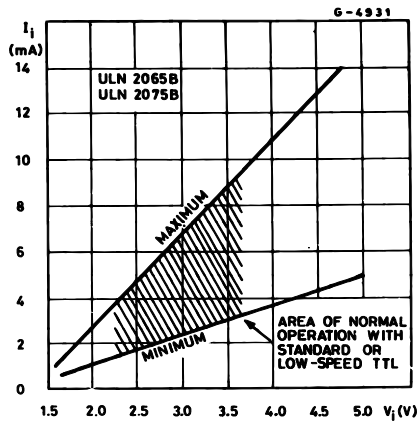


Figure 10 : Input Current as a Function of Input Voltage.

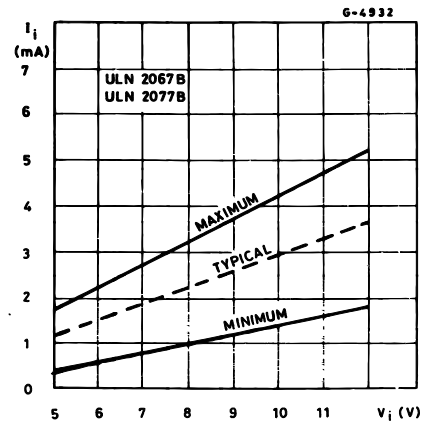
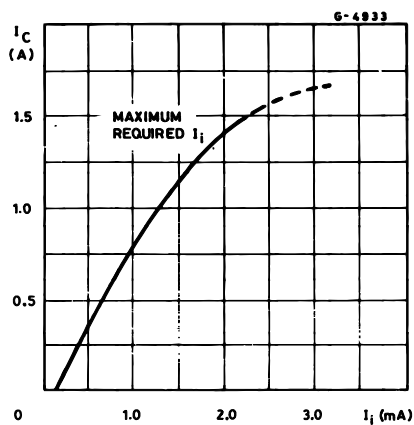


Figure 11 : Collector Current as a Function of Input Current.



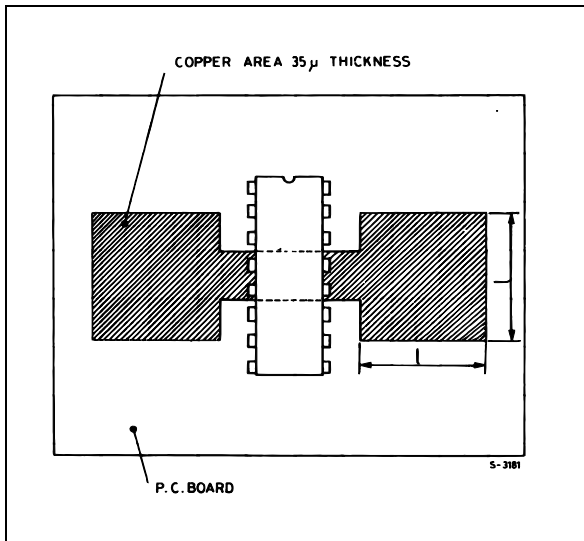
**MOUNTING INSTRUCTIONS**

The  $R_{th\ j-amb}$  can be reduced by soldering the GND pins to a suitable copper area of the printed circuit board (Fig. 12) or to an external heatsink (Fig. 13). The diagram of figure 14 shows the maximum dissipable power  $P_{tot}$  and the  $R_{th\ j-amb}$  as a function of the side "l" of two equal square copper areas having a thickness of  $35\ \mu$  (1.4 mils).

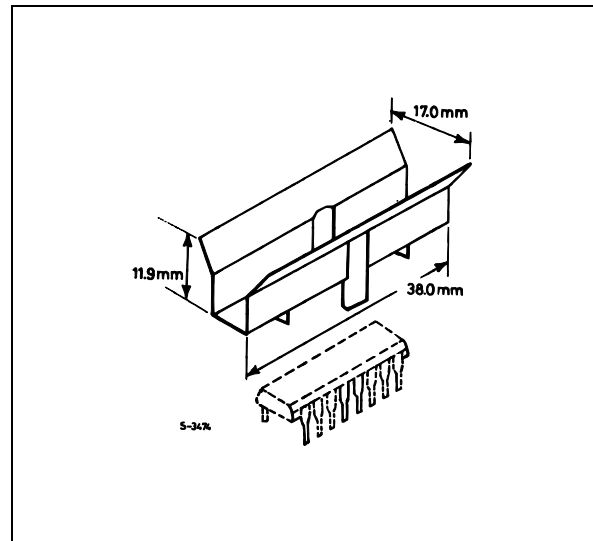
During soldering the pins temperature must not exceed  $260\ ^\circ\text{C}$  and the soldering time must not be longer than 12 seconds.

The external heatsink or printed circuit copper area must be connected to electrical ground.

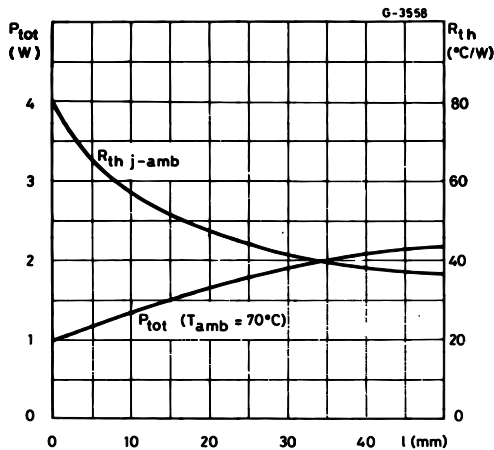
**Figure 12 :** Example of P.C. Board Area which is Used as Heatsink.



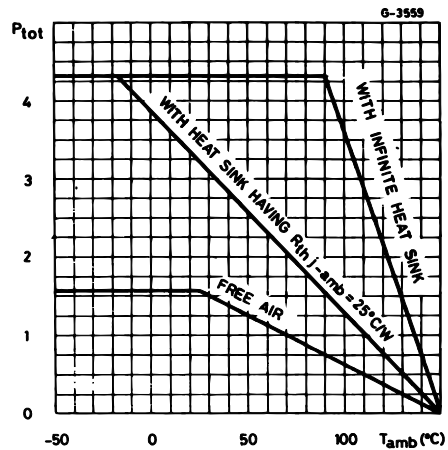
**Figure 13 :** External Heatsink Mounting Example.



**Figure 14 :** Maximum Dissipable Power and Junction to Ambient Thermal Resistance vs. Side "l".

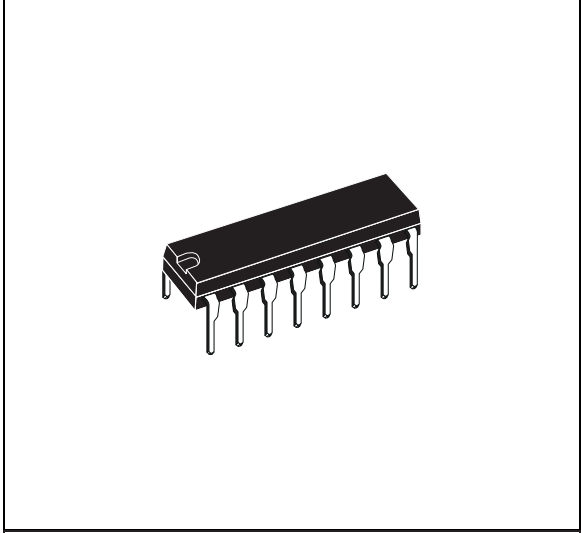


**Figure 15 :** Maximum Allowable Power Dissipation vs. Ambient Temperature.

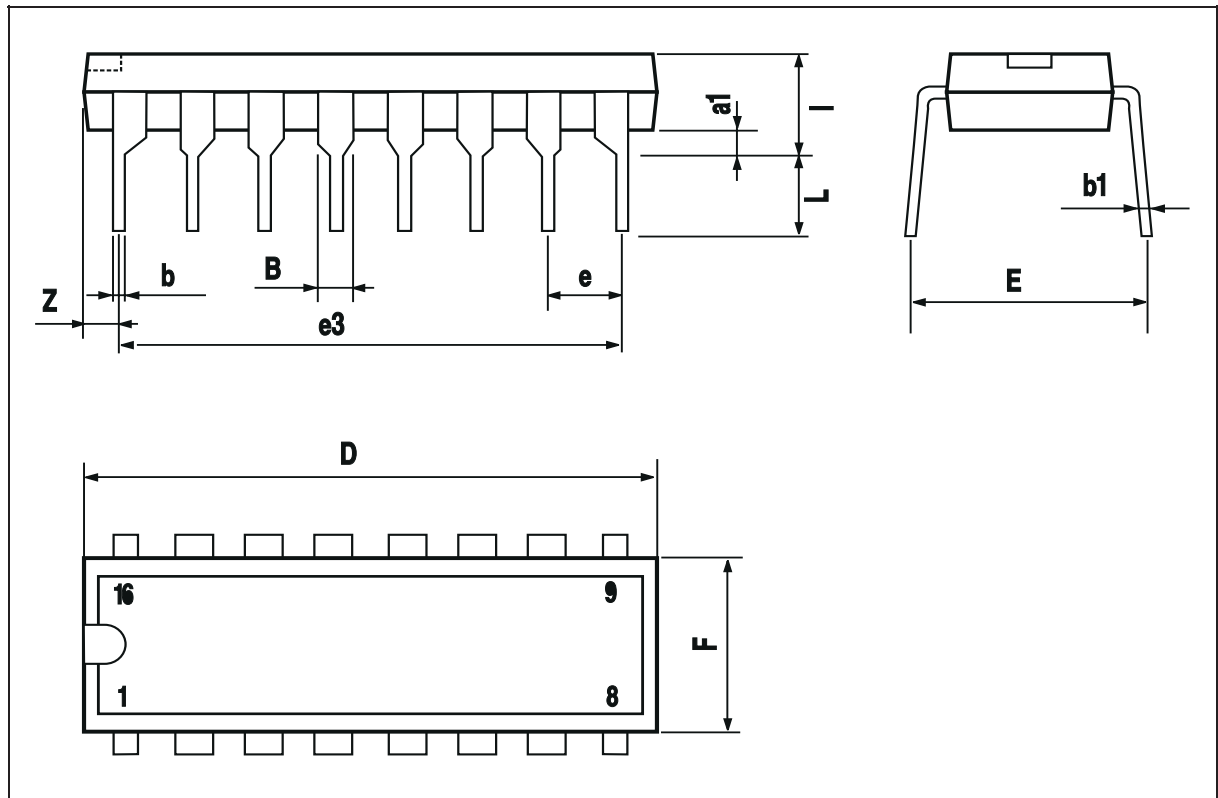


DIM.	mm			inch		
	MIN.	TYP.	MAX.	MIN.	TYP.	MAX.
a1	0.51			0.020		
B	0.85		1.40	0.033		0.055
b		0.50			0.020	
b1	0.38		0.50	0.015		0.020
D			20.0			0.787
E		8.80			0.346	
e		2.54			0.100	
e3		17.78			0.700	
F			7.10			0.280
I			5.10			0.201
L		3.30			0.130	
Z			1.27			0.050

**OUTLINE AND MECHANICAL DATA**



**Powerdip 16**



Information furnished is believed to be accurate and reliable. However, STMicroelectronics assumes no responsibility for the consequences of use of such information nor for any infringement of patents or other rights of third parties which may result from its use. No license is granted by implication or otherwise under any patent or patent rights of STMicroelectronics. Specifications mentioned in this publication are subject to change without notice. This publication supersedes and replaces all information previously supplied. STMicroelectronics products are not authorized for use as critical components in life support devices or systems without express written approval of STMicroelectronics.

The ST logo is a registered trademark of STMicroelectronics.  
All other names are the property of their respective owners

© 2003 STMicroelectronics - All rights reserved

**STMicroelectronics GROUP OF COMPANIES**

Australia – Belgium - Brazil - Canada - China – Czech Republic - Finland - France - Germany - Hong Kong - India - Israel - Italy - Japan -  
Malaysia - Malta - Morocco - Singapore - Spain - Sweden - Switzerland - United Kingdom - United States  
[www.st.com](http://www.st.com)