

80 V - 1.5 A QUAD DARLINGTON SWITCHES

- OUTPUT CURRENT TO 1.5 A EACH DARLINGTON
- MINIMUM BREAKDOWN 80 V
- SUSTAINING VOLTAGE AT LEAST 50 V
- INTEGRAL SUPPRESSION DIODES (ULN2065B, ULN2067B, ULN2069B and ULN2071B)
- ISOLATED DARLINGTON PINOUT (ULN2075B and ULN2077B)
- VERSIONS COMPATIBLE WITH ALL POPULAR LOGIC FAMILIES

DESCRIPTION

Designed to interface logic to a wide variety of high current, high voltage loads, these devices each contain four NPN darlington switches delivering up to 1.5 A with a specified minimum breakdown of 80 V and a sustaining voltage of 50 V. The ULN2065B, ULN2067B, ULN2069B and ULN2071B contain integral suppression diodes for inductive loads and have common emitters; the ULN2075B and ULN2077B feature isolated darlington pinouts and are intended for applications such as emitter follower configurations. Inputs of the ULN2065B, ULN2069B and ULN2075B are compatible with popular 5 V logic families and the ULN2067B, ULN2071B and ULN2077B are compatible with 6-15 VCMOS and PMOS. The ULN2069B and ULN2071B include a predriver stage to provide extra gain, reducing the load on control logic.

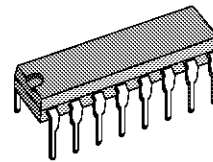

POWERDIP
12 + 2 + 2

PIN CONNECTIONS AND ORDER CODES

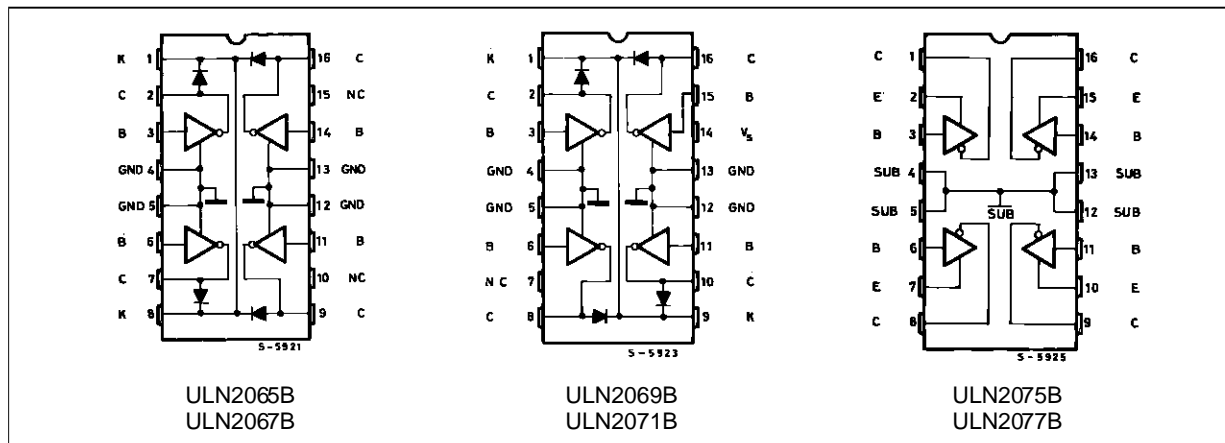

ULN2065B-ULN2067B-ULN2069B-ULN2071B-ULN2075B-ULN2077B

SCHEMATIC DIAGRAM

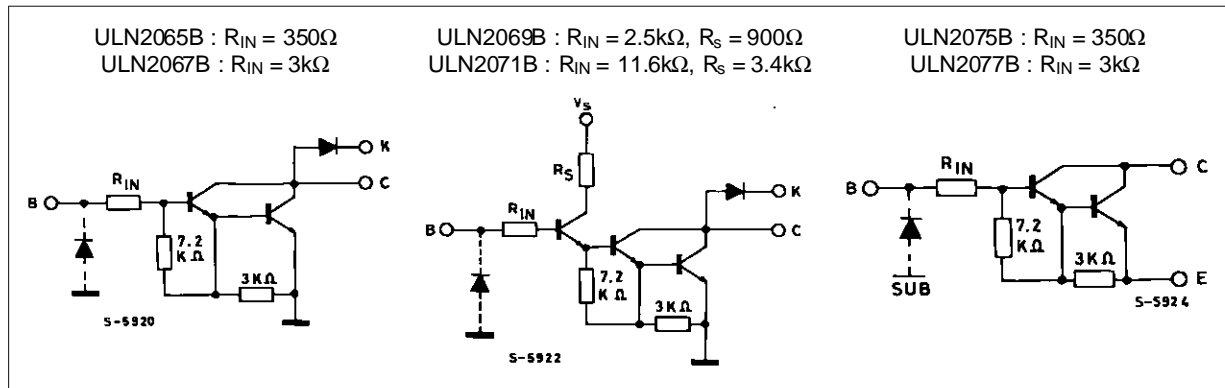

ABSOLUTE MAXIMUM RATINGS

Symbol	Parameter	Value	Unit
V_{CEX}	Output Voltage	80	V
$V_{CE(sus)}$	Output Sustaining Voltage	50	V
I_O	Output Current	1.75	A
V_i	Input Voltage	for ULN2075B – 2077B	60
		for ULN2067B – 2071B	30
		for ULN2065B – 2069B	15
I_i	Input Current	25	mA
V_S	Supply Voltage	for ULN2069B	10
		for ULN2071B	20
P_{tot}	Power Dissipation	at $T_{pins} = 90^\circ C$	4.3
		at $T_{amb} = 70^\circ C$	1
T_{amb}	Operating Ambient Temperature Range	- 20 to 85	$^\circ C$
T_{stg}	Storage Temperature	- 55 to 150	$^\circ C$

ELECTRICAL CHARACTERISTICS ($T_{amb} = 25^\circ C$ unless otherwise specified)

Symbol	Parameter	Test Conditions	Min.	Typ.	Max.	Unit	Fig.
I_{CEX}	Output Leakage Current	$V_{CE} = 80V$ $T_{amb} = 25^\circ C$ $T_{amb} = 70^\circ C$			100 500	μA μA	1
$V_{CE(sus)}$	Collector-emitter Sustaining Voltage	$I_C = 100mA$, $V_i = 0.4V$	50			V	2
$V_{CE(sat)}$	Collector-emitter Saturation Voltage	$I_C = 500mA$ $I_B = 625\mu A$			1.1	V	3
		$I_C = 750mA$ $I_B = 935\mu A$			1.2	V	3
		$I_C = 1A$ $I_B = 1.25mA$			1.3	V	3
		$I_C = 1.25A$ $I_B = 2mA$			1.4	V	3
		$I_C = 1.5A$ $I_B = 2.25mA$			1.5	V	3
$I_{i(on)}$	Input Current	for ULN2065B and ULN2075B					
		$V_i = 2.4V$	1.4		4.3	mA	4
		$V_i = 3.75V$	3.3		9.6	mA	4
		for ULN2067B and ULN2077B					
		$V_i = 5V$	0.6		1.8	mA	4
		$V_i = 12V$	1.7		5.2	mA	4
		for ULN2069B					
		$V_i = 2.75V$			5.5	mA	4
		$V_i = 3.75V$			10	mA	4
		for ULN2071B					
$V_i = 5V$			4	mA	4		
$V_i = 12V$			12.5	mA	4		

ULN2065B-ULN2067B-ULN2069B-ULN2071B-ULN2075B-ULN2077B

ELECTRICAL CHARACTERISTICS ($T_{amb} = 25^{\circ}\text{C}$ unless otherwise specified) (continued)

Symbol	Parameter	Test Conditions	Min.	Typ.	Max.	Unit	Fig.
$V_{i(on)}$	Input Voltage	$V_{CE} = 2\text{V}, I_C = 1\text{A}$ ULN2065B, ULN2075B ULN2067B, ULN2077B $V_{CE} = 2\text{V}, I_C = 1.5\text{A}$ ULN2065B, ULN2075B ULN2067B, ULN2077B ULN2069B ULN2071B			2 6.5 2.5 10 2.75 5	V V V V V V	5 5 5 5 5 5
I_s	Supply Current	for ULN2069B $I_C = 500\text{mA}, V_i = 2.75\text{V}$ for ULN2071B $I_C = 500\text{mA}, V_i = 5\text{V}$			6 4.5	mA mA	8 8
t_{PLH}	Turn-on Delay Time	$0.5 V_i$ to $0.5 V_o$			1	μs	
t_{PHL}	Turn-off Delay Time	$0.5 V_i$ to $0.5 V_o$			1.5	μs	
I_R	Clamp Diode Leakage Current	for ULN2065B-ULN2067B and ULN2069B-ULN2071B $V_R = 80\text{V}$ $T_{amb} = 25^{\circ}\text{C}$ $T_{amb} = 70^{\circ}\text{C}$			50 100	μA μA	6
V_F	Clamp Diode Forward Voltage	for ULN2065B-ULN2067B and ULN2069B-ULN2071B $I_F = 1\text{A}$ $I_F = 1.5\text{A}$			1.75 2	V V	7

- Notes :**
1. Input voltage is with reference to the substrate (no connection to any other pins) for the ULN2075B and ULN2077B reference is ground for all other types.
 2. Input current may be limited by maximum allowable input voltage.

TEST CIRCUITS

Figure 1.

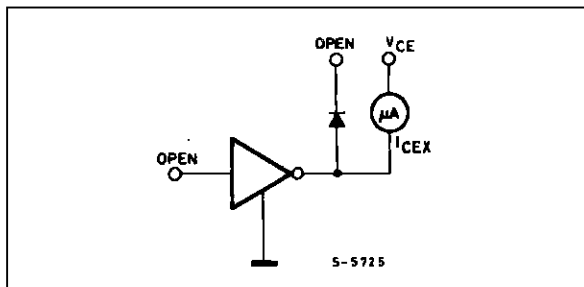

Figure 2.

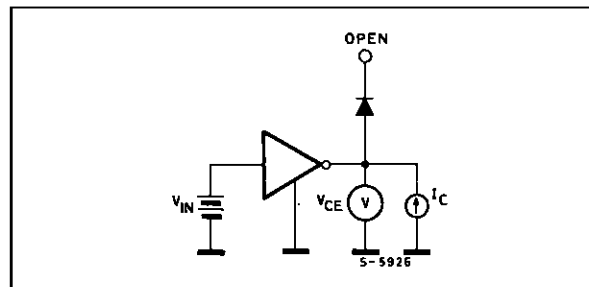

Figure 3.

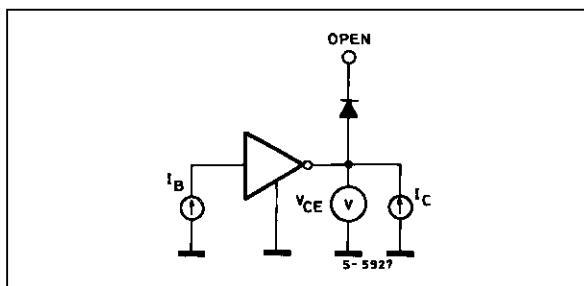

Figure 4.

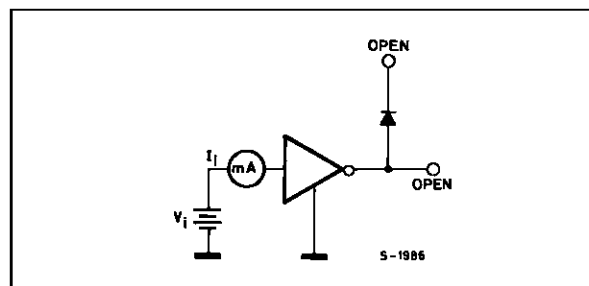

Figure 5.

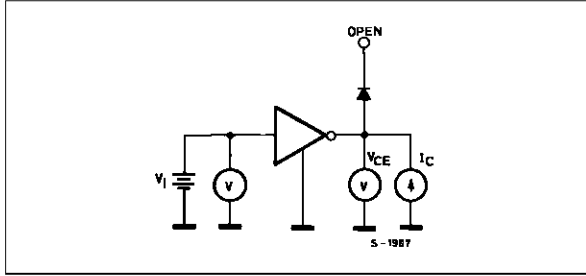

Figure 6.

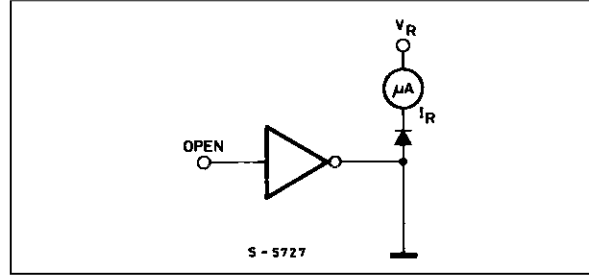

Figure 7.

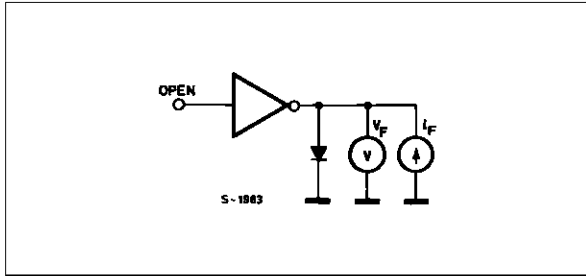

Figure 8.

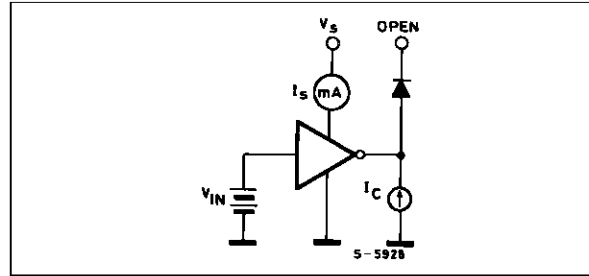

Figure 9 : Input Current as a Function of Input Voltage.

Figure 10 : Input Current as a Function of Input Voltage.

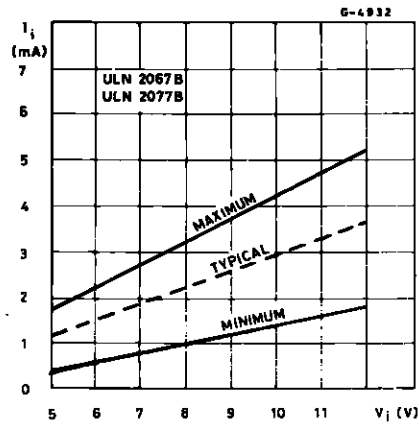
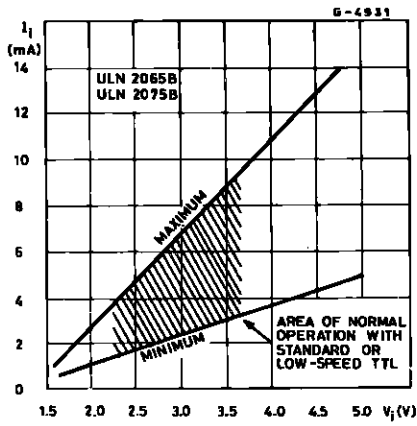
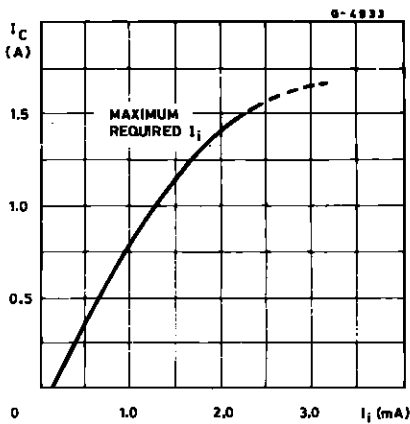

Figure 11 : Collector Current as a Function of Input Current.



MOUNTING INSTRUCTIONS

The $R_{th\ j-amb}$ can be reduced by soldering the GND pins to a suitable copper area of the printed circuit board (Fig. 12) or to an external heatsink (Fig. 13).

The diagram of figure 14 shows the maximum dissippable power P_{tot} and the $R_{th\ j-amb}$ as a function of the side "∞" of two equal square copper areas having a thickness of $35\ \mu$ (1.4 mils).

During soldering the pins temperature must not exceed $260\ ^\circ\text{C}$ and the soldering time must not be longer than 12 seconds.

The external heatsink or printed circuit copper area must be connected to electrical ground.

Figure 12 : Example of P.C. Board Area which is Used as Heatsink.

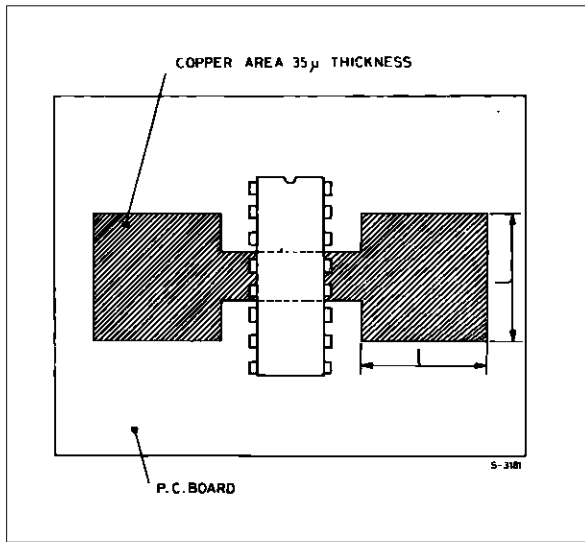

Figure 13 : External Heatsink Mounting Example.

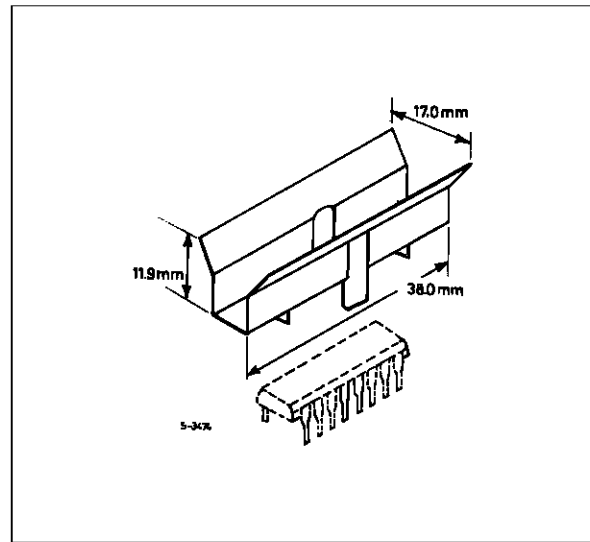

Figure 14 : Maximum Dissippable Power and Junction to Ambient Thermal Resistance vs. Side "l".

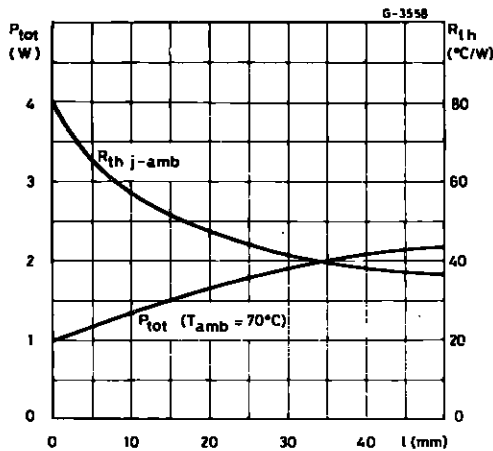
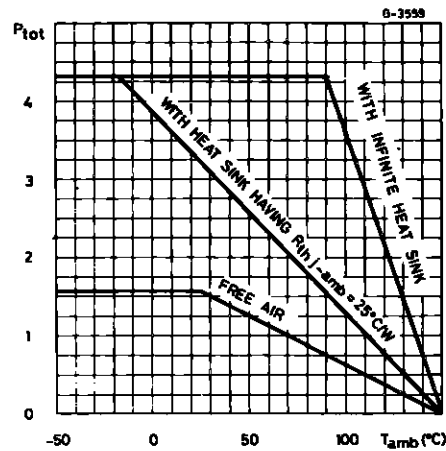

Figure 15 : Maximum Allowable Power Dissipation vs. Ambient Temperature.



ULN2065B-ULN2067B-ULN2069B-ULN2071B-ULN2075B-ULN2077B

POWERDIP 16 PACKAGE MECHANICAL DATA

DIM.	mm			inch		
	MIN.	TYP.	MAX.	MIN.	TYP.	MAX.
a1	0.51			0.020		
B	0.85		1.40	0.033		0.055
b		0.50			0.020	
b1	0.38		0.50	0.015		0.020
D			20.0			0.787
E		8.80			0.346	
e		2.54			0.100	
e3		17.78			0.700	
F			7.10			0.280
I			5.10			0.201
L		3.30			0.130	
Z			1.27			0.050

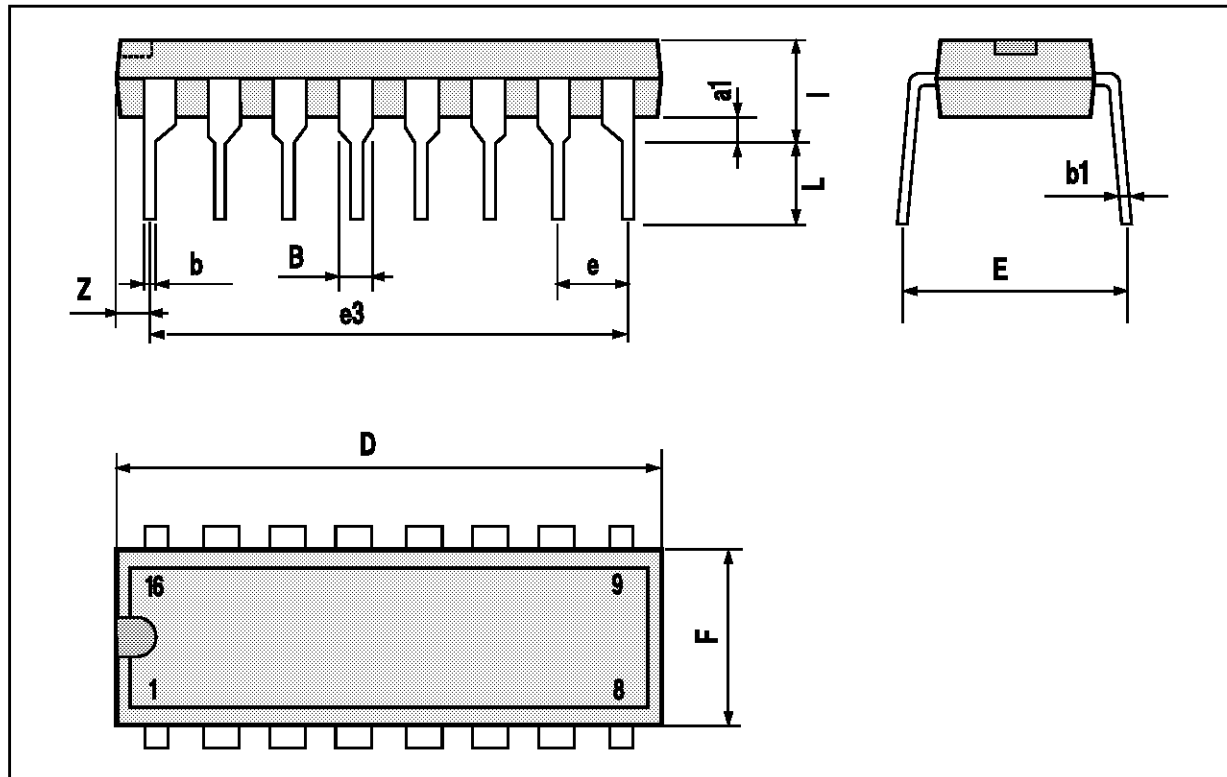

Information furnished is believed to be accurate and reliable. However, SGS-THOMSON Microelectronics assumes no responsibility for the consequences of use of such information nor for any infringement of patents or other rights of third parties which may result from its use. No license is granted by implication or otherwise under any patent or patent rights of SGS-THOMSON Microelectronics. Specifications mentioned in this publication are subject to change without notice. This publication supersedes and replaces all information previously supplied. SGS-THOMSON Microelectronics products are not authorized for use as critical components in life support devices or systems without express written approval of SGS-THOMSON Microelectronics.

© 1994 SGS-THOMSON Microelectronics - All Rights Reserved

SGS-THOMSON Microelectronics GROUP OF COMPANIES

Australia - Brazil - France - Germany - Hong Kong - Italy - Japan - Korea - Malaysia - Malta - Morocco - The Netherlands - Singapore - Spain - Sweden - Switzerland - Taiwan - Thailand - United Kingdom - U.S.A.