

5 kW two-channel interleaved CCM PFC EVAL board

IKWH40N65WR6, IDW60C65D1 and 1ED44175 in high frequency PFC application

About this document

Scope and purpose

This document provides an overview of the evaluation board EVAL-PFC5KIKWWR6SYS and explains the main features, key data, and mechanical dimensions of the board.

The EVAL-PFC5KIKWWR6SYS is a fast-switching, analog-controlled, two-channel interleaved 5 kW continuous conduction mode (CCM) power factor correction (PFC) converter with Infineon's TRENCHSTOP™ 5 WR6 IGBT (IKWH40N65WR6). This evaluation board demonstrates the use of the WR6 IGBT at very high switching frequencies that offers many system benefits, such as a smaller PFC choke, overall reduced system size, and lower bill of material (BOM) cost. This document also presents a very efficient system solution for a 5 kW, interleaved, CCM PFC converter based on Infineon's TRENCHSTOP™ 5 WR6 IGBT, Infineon's low-side gate driver (1ED44175), and Rapid1 power silicon diode (IDW60C65D1).

EVAL-PFC5KIKWWR6SYS can operate with a wide range of AC input voltages (180 V–264 V) and regulates the output voltage to 400 V with a maximum current of up to 12.5 A. This document explains the design, development, and experimental results of the interleaved CCM PFC converter that can be adapted to specific application requirements, such as high-power switched mode power supplies (SMPSs) and air conditioners in major home appliances.

Intended audience

This user guide is intended for all engineers and technical specialists experienced in power electronics. The evaluation board is intended to be used under laboratory conditions and only by trained personnel.

Evaluation Board

This board is used during the development phase to evaluate and measure device characteristics and performance.

Note: PCB and auxiliary circuits are NOT optimized for final customer design.

Note: Boards do not necessarily meet safety, EMI, quality standards (for example UL, CE) requirements.

Important notice

Important notice

“Evaluation Boards and Reference Boards” shall mean products embedded on a printed circuit board (PCB) for demonstration and/or evaluation purposes, which include, without limitation, demonstration, reference and evaluation boards, kits and design (collectively referred to as “Reference Board”).

Environmental conditions have been considered in the design of the Evaluation Boards and Reference Boards provided by Infineon Technologies. The design of the Evaluation Boards and Reference Boards has been tested by Infineon Technologies only as described in this document. The design is not qualified in terms of safety requirements, manufacturing and operation over the entire operating temperature range or lifetime.

The Evaluation Boards and Reference Boards provided by Infineon Technologies are subject to functional testing only under typical load conditions. Evaluation Boards and Reference Boards are not subject to the same procedures as regular products regarding returned material analysis (RMA), process change notification (PCN) and product discontinuation (PD).

Evaluation Boards and Reference Boards are not commercialized products, and are solely intended for evaluation and testing purposes. In particular, they shall not be used for reliability testing or production. The Evaluation Boards and Reference Boards may therefore not comply with CE or similar standards (including but not limited to the EMC Directive 2004/EC/108 and the EMC Act) and may not fulfill other requirements of the country in which they are operated by the customer. The customer shall ensure that all Evaluation Boards and Reference Boards will be handled in a way which is compliant with the relevant requirements and standards of the country in which they are operated.

The Evaluation Boards and Reference Boards as well as the information provided in this document are addressed only to qualified and skilled technical staff, for laboratory usage, and shall be used and managed according to the terms and conditions set forth in this document and in other related documentation supplied with the respective Evaluation Board or Reference Board.

It is the responsibility of the customer’s technical departments to evaluate the suitability of the Evaluation Boards and Reference Boards for the intended application, and to evaluate the completeness and correctness of the information provided in this document with respect to such application.

The customer is obliged to ensure that the use of the Evaluation Boards and Reference Boards does not cause any harm to persons or third party property.

The Evaluation Boards and Reference Boards and any information in this document is provided "as is" and Infineon Technologies disclaims any warranties, express or implied, including but not limited to warranties of non-infringement of third party rights and implied warranties of fitness for any purpose, or for merchantability.

Infineon Technologies shall not be responsible for any damages resulting from the use of the Evaluation Boards and Reference Boards and/or from any information provided in this document. The customer is obliged to defend, indemnify and hold Infineon Technologies harmless from and against any claims or damages arising out of or resulting from any use thereof.

Infineon Technologies reserves the right to modify this document and/or any information provided herein at any time without further notice.

5 kW two-channel interleaved CCM PFC EVAL board
IKWH40N65WR6, IDW60C65D1 and 1ED44175 in high frequency PFC application



Safety precautions

Safety precautions

Note: Please note the following warnings regarding the hazards associated with development systems.

Table 1 Safety precautions

	<p>Warning: The DC link potential of this board is up to 400 VDC. When measuring voltage waveforms by oscilloscope, high voltage differential probes must be used. Failure to do so may result in personal injury or death.</p>
	<p>Warning: The evaluation board contains DC bus capacitors which take time to discharge after removal of the main supply. Before working on the drive system, wait five minutes for capacitors to discharge to safe voltage levels. Failure to do so may result in personal injury or death.</p>
	<p>Warning: The evaluation board is connected to the grid input during testing. Hence, high-voltage differential probes must be used when measuring voltage waveforms by oscilloscope. Failure to do so may result in personal injury or death.</p>
	<p>Caution: The heat sink and device surfaces of the evaluation or reference board may become hot during testing. Hence, necessary precautions are required while handling the board. Failure to comply may cause injury.</p>
	<p>Caution: Only personnel familiar with the drive, power electronics and associated machinery should plan, install, commission and subsequently service the system. Failure to comply may result in personal injury and/or equipment damage.</p>
	<p>Caution: The evaluation board contains parts and assemblies sensitive to electrostatic discharge (ESD). Electrostatic control precautions are required when installing, testing, servicing or repairing the assembly. Component damage may result if ESD control procedures are not followed. If you are not familiar with electrostatic control procedures, refer to the applicable ESD protection handbooks and guidelines.</p>
	<p>Caution: A drive that is incorrectly applied or installed can lead to component damage or reduction in product lifetime. Wiring or application errors such as undersizing the motor, supplying an incorrect or inadequate AC supply, or excessive ambient temperatures may result in system malfunction.</p>
	<p>Caution: The evaluation or reference board is shipped with packing materials that need to be removed prior to installation. Failure to remove all packing materials that are unnecessary for system installation may result in overheating or abnormal operating conditions.</p>

Table of contents

About this document	1
Important notice	2
Safety precautions	3
Table of contents	4
1 The board at a glance	5
1.1 Interleaved PFC	5
1.2 Block diagram of EVAL-PFC5KIKWWR6SYS	6
2 System and functional description	8
2.1 General overview.....	8
2.1.1 UCC28070—analogue controller.....	9
2.1.2 IKWH40N65WR6—fast switching WR6 IGBT	9
2.1.3 IDW60C65D1—rapid1 power silicon diode	9
2.1.4 1ED44175—low-side gate driver	10
2.2 Board specifications.....	10
3 System design	11
3.1 Schematics	11
3.2 Layout	16
3.3 Bill of material	19
3.4 Connector details	23
4 System performance	24
4.1 Efficiency and PFC measurements	24
4.2 Startup behavior	25
4.3 Input current and inductor current cancellation	26
4.4 Switching performance of IGBT at steady state.....	29
4.5 Output ripple voltage	30
4.6 Input voltage and input current.....	32
4.7 Load step tests	33
4.8 Thermal measurements.....	35
5 Conclusions	37
6 References and appendices	38
6.1 Abbreviations and definitions.....	38
6.2 References	38
6.3 Additional information.....	38
Revision history	39

The board at a glance

1 The board at a glance

This section describes the basic concept of interleaved PFC converters and gives a brief introduction about the design of the EVAL-PFC5KIKWWR6SYS board.

1.1 Interleaved PFC

For power factor correction, the standard boost converter is most commonly used because it enables easy control of the input current and keeps the output voltage constant. Increasing the output power and improving the overall efficiency at higher powers leads to the use of multiple converters connected in parallel, e.g. two or three channels connected in parallel. In addition, as the switches are 180° out-of-phase for a two-channel converter and 120° out-of-phase for a three-channel interleaved converter, the input current ripple is significantly reduced and the interleaved operation uses the same load capacitors. This also eases the burden of filtering the conducted EMI noise and helps reduce the EMI filter and input capacitor (C_{IN}) sizes.

This approach also has other advantages such as ease of implementation, use of smaller components, and better heat distribution. At the same time, the current ripple of the output capacitors is reduced and evenly distributed in each channel. This can extend the capacitors' life and reduce their size and cost. Compared to a single-boost converter, the inductors in a two- or three-channel interleaved PFC take only half or one-third of the current, respectively. These inductors can, therefore, achieve the same high power with much lower inductance values, resulting in higher power density for a given rated power.

Figure 1 is an example of a two-channel interleaved PFC converter followed by a rectifier stage. The detailed operating principles and the main waveforms are shown in Figure 2.

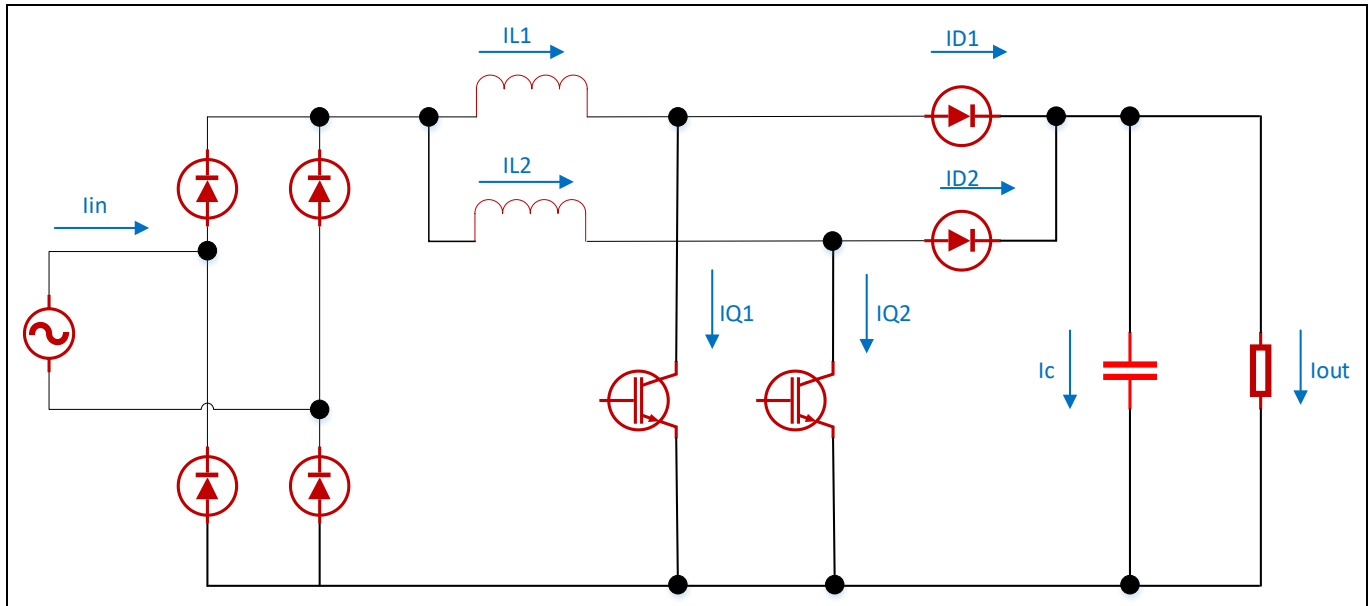

Figure 1 Block diagram of a two-channel interleaved PFC

The board at a glance

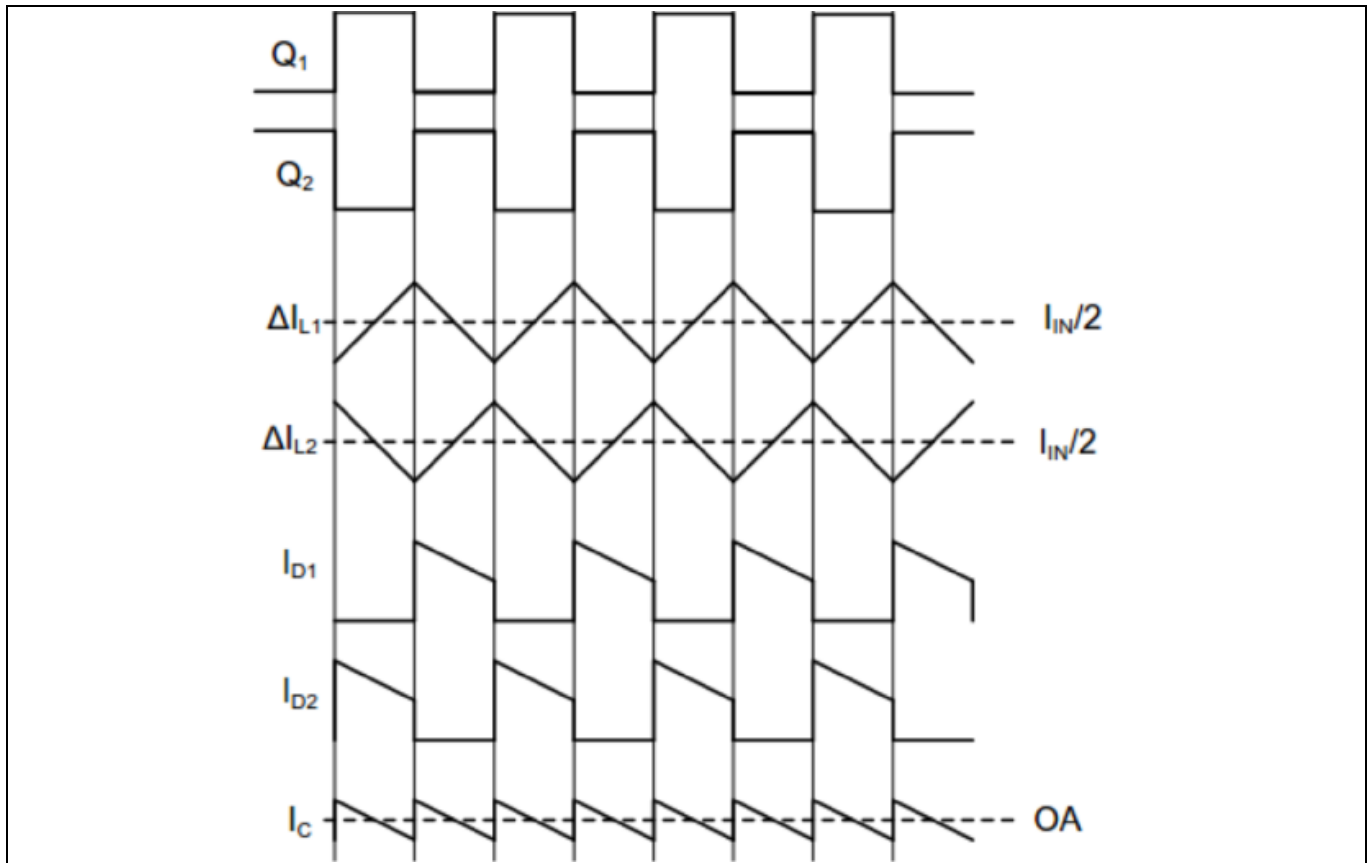

Figure 2 Principles of operation for the two-channel interleaved PFC

1.2 Block diagram of EVAL-PFC5KIKWWR6SYS

Reducing the size of power converters by increasing the switching frequency and reducing the magnetic component's size is a goal that has been pursued for decades. This applies particularly when IGBTs are used in a switched mode power supply. A higher switching frequency leads directly to smaller inductance and lower system cost. A high-performance IGBT is the key component that helps users reduce operating costs and gain larger market shares. Infineon's WR6 IGBT is specifically optimized for PFC applications in boost topology and therefore, offers an excellent price to performance ratio even for cost-sensitive markets.

The EVAL-PFC5KIKWWR6SYS is an evaluation board for demonstrating the switching performance of TRENCHSTOP™ 5 WR6 IGBT IKWH40N65WR6 with high switching frequencies of up to 75 kHz in a boost PFC application. The block diagram of EVAL-PFC5KIKWWR6SYS is shown in Figure 3. It displays the analog controller UCC28070, the TRENCHSTOP™ 5 IGBT IKWH40N65WR6, the low-side gate driver 1ED44175, and the rapid1 power silicon diode IDW60C65D1.

This evaluation board includes:

- Two-channel boost converters
- High-speed 650 V, 40 A reverse conducting TRENCHSTOP™ 5 WR6 IGBT in a TO-247-3-HCC package
- Gate driver ICs for WR6 IGBTs
- Rapid1 power silicon diode as boost output diode
- Loss-free current monitoring for switching current
- 15 V auxiliary power supply
- Connectors for easy setup

5 kW two-channel interleaved CCM PFC EVAL board

IKWH40N65WR6, IDW60C65D1 and 1ED44175 in high frequency PFC application



The board at a glance

- External force cooling for high power application

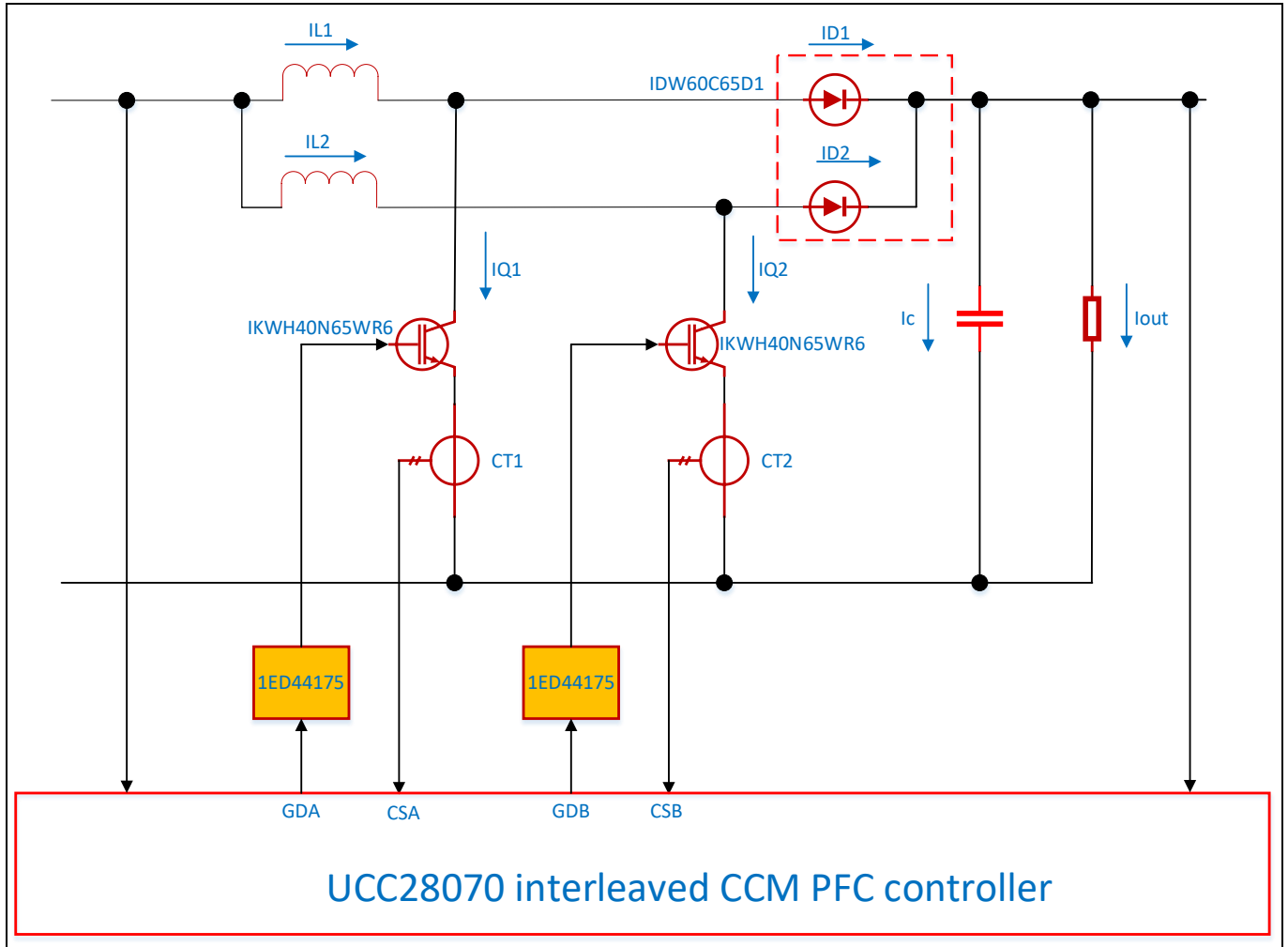

Figure 3 Block diagram of EVAL-PFC5KIKWWR6SYS

2 System and functional description

2.1 General overview

The EVAL-PFC5KIKWWR6SYS is a reference design of a 5 kW interleaved PFC for, but not limited to, floor-standing air conditioners.



Figure 4 Board view of EVAL-PFC5KIKWWR6SYS

Design characteristics of EVAL-PFC5KIKWWR6SYS includes:

Board performance:

- High power factor, PF > 0.995
- Low THDi
- High efficiency

Control technology incorporated:

- CCM average current control
- Frequency dithering for enhanced EMI reduction

Fault protection:

- Input undervoltage protection and overvoltage protection
- Output overvoltage protection
- Open-circuit protection for AC input and DC output
- Cycle-by-cycle peak current limiting
- Thermal shutdown for power semiconductors

5 kW two-channel interleaved CCM PFC EVAL board

IKWH40N65WR6, IDW60C65D1 and 1ED44175 in high frequency PFC application



System and functional description

2.1.1 UCC28070—analog controller

As Infineon does not have a dedicated interleaved PFC controller, the UCC28070 from Texas Instruments which is a popular choice in this field, was used. Figure 5 shows a simplified application diagram of the UCC28070.

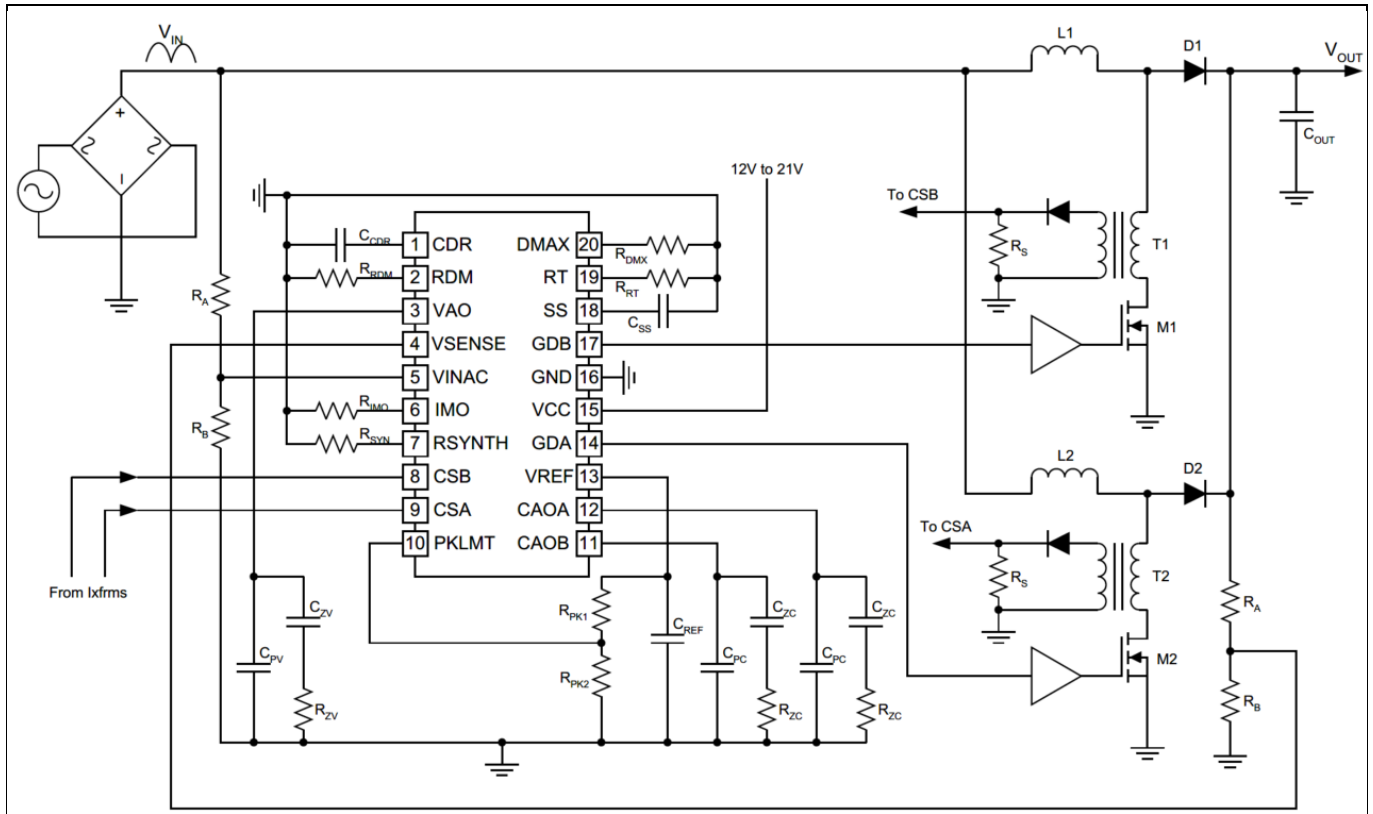

Figure 5 Simplified application diagram of UCC28070

2.1.2 IKWH40N65WR6—fast switching WR6 IGBT

IKWH40N65WR6 is a high speed, 650 V, 40 A reverse-conducting TRENCHSTOP™ 5 WR6 IGBT in a TO-247-3-HCC package with wide creepage and clearance distances. This device technology, includes a monolithically integrated diode, is specifically optimized for boost PFC applications and offers the best price to performance ratio. It also fits well in mainstream designs for very high switching frequencies (up to 75kHz.)

The IKWH40N65WR6 has the following key features:

- Very low V_{CEsat} of 1.55 V at 25°C
- Low E_{sw}
- Monolithically integrated diode
- Good $R_{(G)}$ controllability
- Low T_j and T_c that enable lower heat sink and cooling costs
- New package with high creepage and clearance distances to improve system reliability

2.1.3 IDW60C65D1—rapid1 power silicon diode

IDW60C65D1 is a rapid 1, 650 V, 60 A, emitter-controlled power silicon diode in common cathode configuration; in a TO-247-3 package. It enables design optimization for more compact dimensions, easier assembly, and consequently lower costs.

5 kW two-channel interleaved CCM PFC EVAL board

IKWH40N65WR6, IDW60C65D1 and 1ED44175 in high frequency PFC application



System and functional description

Its features include:

- Highest softness factor for ultimate softness and low EMI filtering
- 1.35 V temperature-stable forward voltage (V_F)
- Lowest $I_{r_{ms}}$ to provide lowest turn-on losses in the boost switch

2.1.4 1ED44175—low-side gate driver

1ED44175 is an EiceDRIVER™ 25 V, single-channel, low-side, non-inverting gate driver for IGBTs; with typical 2.6 A source and sink currents in a tiny 6-lead PG-SOT23 package. 1ED44175N01B saves cost and space by integrating the comparator. The new low-side gate driver utilizes Infineon's proprietary latch immune CMOS technology to enable a rugged monolithic construction while achieving best-in-class fault reporting accuracy with an over current protect (OCP) threshold tolerance of +/-5%. Its features include:

- -0.246 V overcurrent threshold with $\pm 5\%$ tolerance accuracy
- Overcurrent detection with negative voltage input
- Single pin for fault output and Enable
- Programmable fault-clear time
- Under voltage lockout for IGBTs
- CMOS Schmitt-triggered inputs
- 3.3 V, 5 V, and 15 V input logic compatibility
- Output in-phase with input
- -10 V_{dc} negative input capability of the OCP pin
- 3 kV electrostatic discharge (ESD) qualified for human-body model (HBM)

2.2 Board specifications

Table 2 lists the key specifications of the EVAL-PFC5KIKWWR6SYS board.

Table 2 EVAL-PFC5KIKWWR6SYS specifications

NO.	Parameters	Symbol	Value
1	Output power	P_{out}	5000 Watt
2	Input voltage range (rms)	V_{in}	180 V _{ac} to 264 V _{ac}
3	Input frequency range	f	50 Hz or 60 Hz
4	Output voltage	V_{DC}	400 V
5	Output ripple voltage	V_{ripple}	20 V
6	Inductance	L2, L3	85 μ H
7	Switching frequency	f_s	60 kHz

System design

3 System design

This chapter contains all the technical information—such as circuit schematics, layout, and components—necessary to meet individual customer requirements and to use EVAL-PFC5KIKWWR6SYS as a basis for developments or evaluations.

The EVAL-PFC5KIKWWR6SYS consists of three blocks—power stage, controller circuit, and auxiliary supply—all of which are on the same board. All surface mounted (SMD) devices are mounted on the bottom layer, enabling customers to modify parameters if necessary.

3.1 Schematics

There are a total of six schematic diagrams in the design. Figures 6–11 describe their functions.

Figure 6 shows the converter’s EMI filter, soft-start control, and diode rectifiers. Connectors X1, X3, and X6 connect to grid line, neutral, and ground respectively. Three metal oxide varistors (MOVs) R58, R60, and R61 and gas discharge tube GT1 form the surge protection circuit. The negative temperature coefficient (NTC) thermistors R54 and R55 limit the input current ramp slope at startup. When the voltage of output capacitors reaches about 230 V, the K1 relay turns on and bypasses R54 and R55. At this point, the PFC converter works with high efficiency.

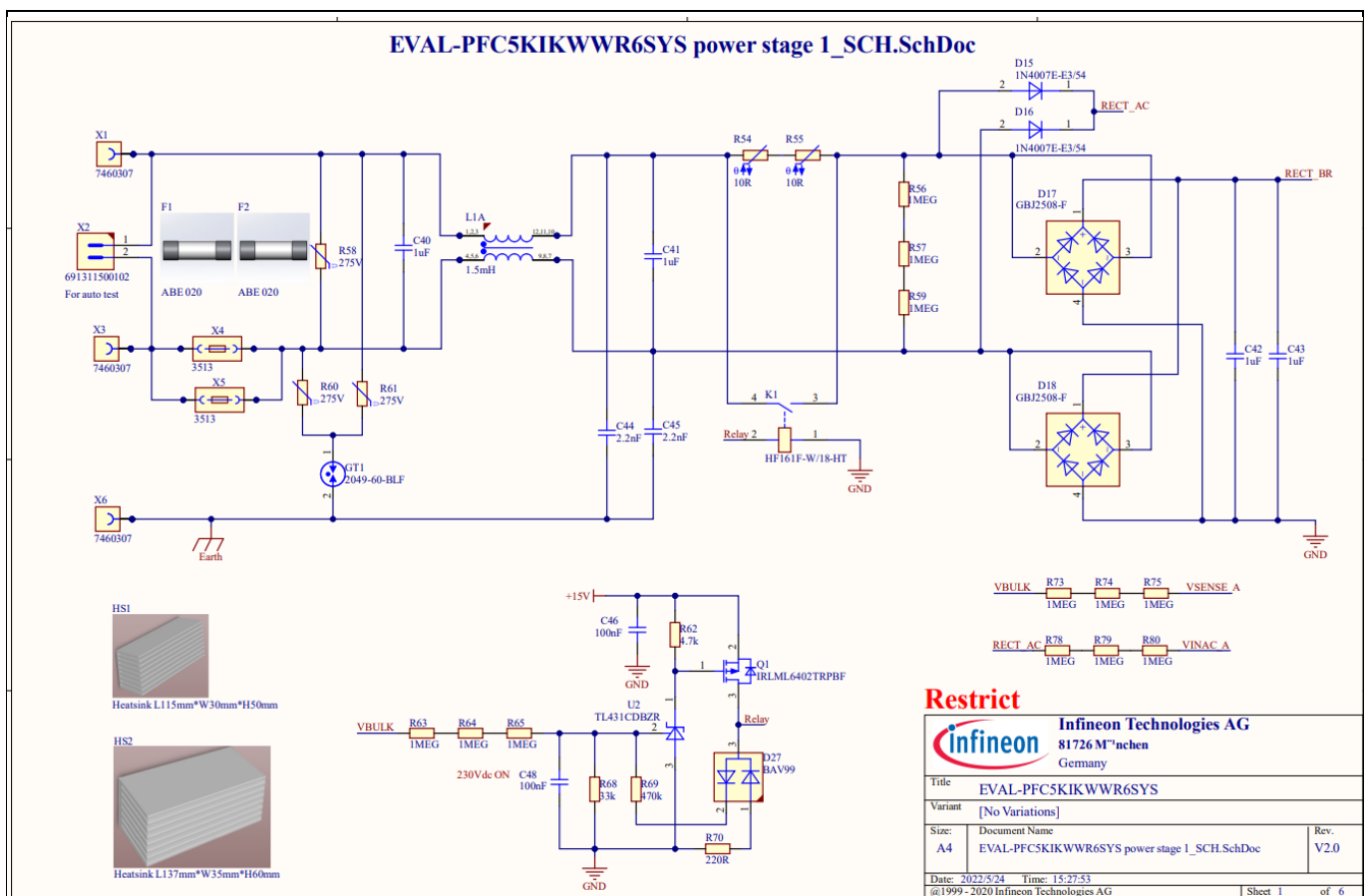

Figure 6 EMI filter, soft-start control, and rectifiers of EVAL-PFC5KIKWWR6SYS

Figure 7 shows two channel-boost converter connected in parallel with 180° out-of-phase control. Each channel has the WR6 IGBT IKWH40N65WR6 as the main switch, and the rapid1 fast-recovery diode IDW60C65D1 with common cathode as the boost diode. In practical applications, customers can replace this common cathode diode with either two separated silicon fast-recovery diodes or two SiC diodes and use them as D21 and D22. A current transformer monitors the IGBT current for normal operation and cycle-by-cycle current limiting. Each

5 kW two-channel interleaved CCM PFC EVAL board

IKWH40N65WR6, IDW60C65D1 and 1ED44175 in high frequency PFC application



System design

gate driver 1ED44175 matches one IGBT. The two boost inductors are from POCO and contain an NPH-L series material core that performs better than inductors with traditional powder material cores.

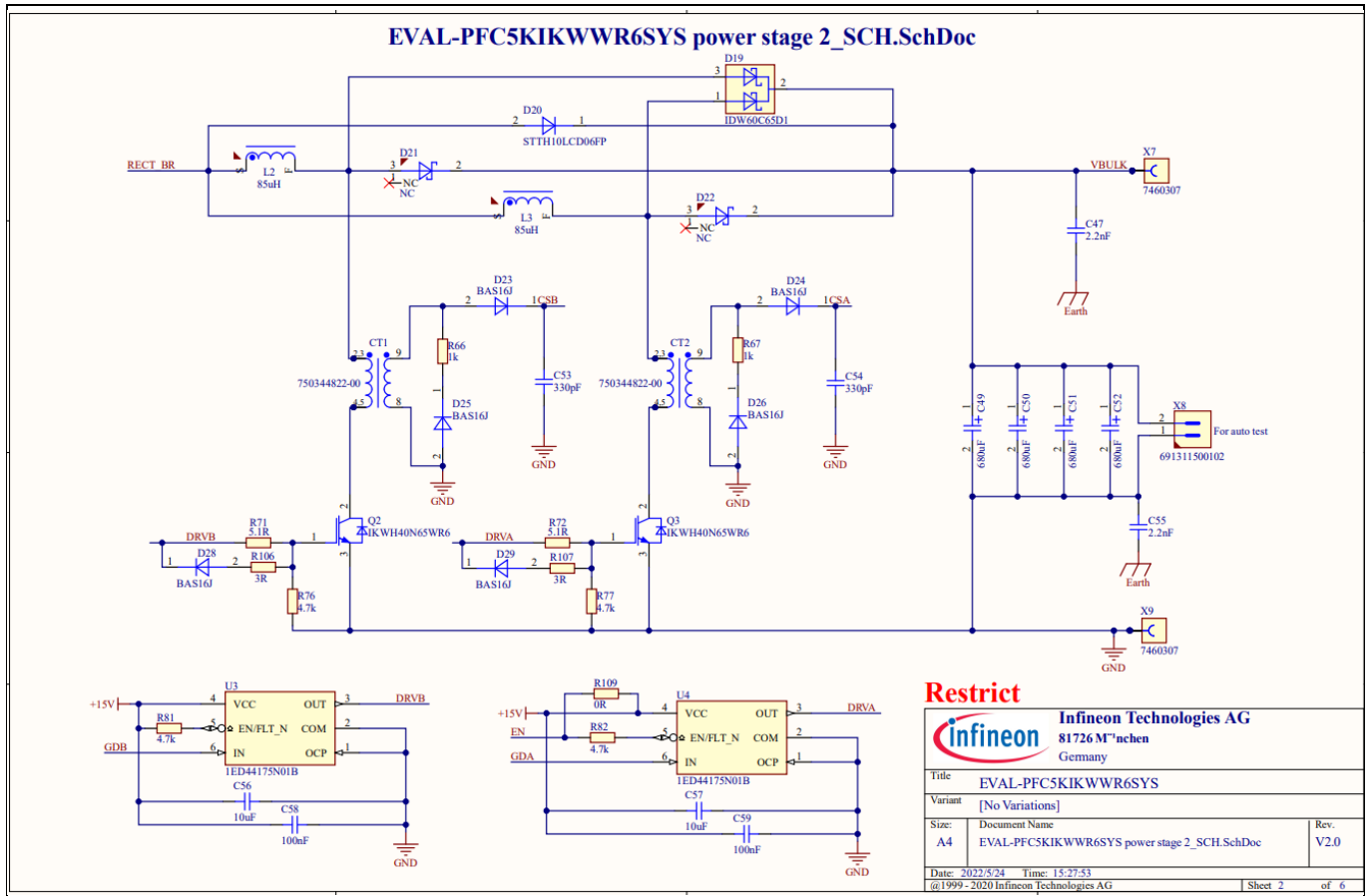

Figure 7 Interleaved PFC power stage of EVAL-PFC5KIKWWR6SYS

Figure 8 shows the UCC28070 analog controller and its parameter settings with external resistors and capacitors. The switching frequency of the converter is set by the potentiometer **R115**. User can easily adjust the switching frequency by changing the set value of R115.

5 kW two-channel interleaved CCM PFC EVAL board IKWH40N65WR6, IDW60C65D1 and 1ED44175 in high frequency PFC application



System design

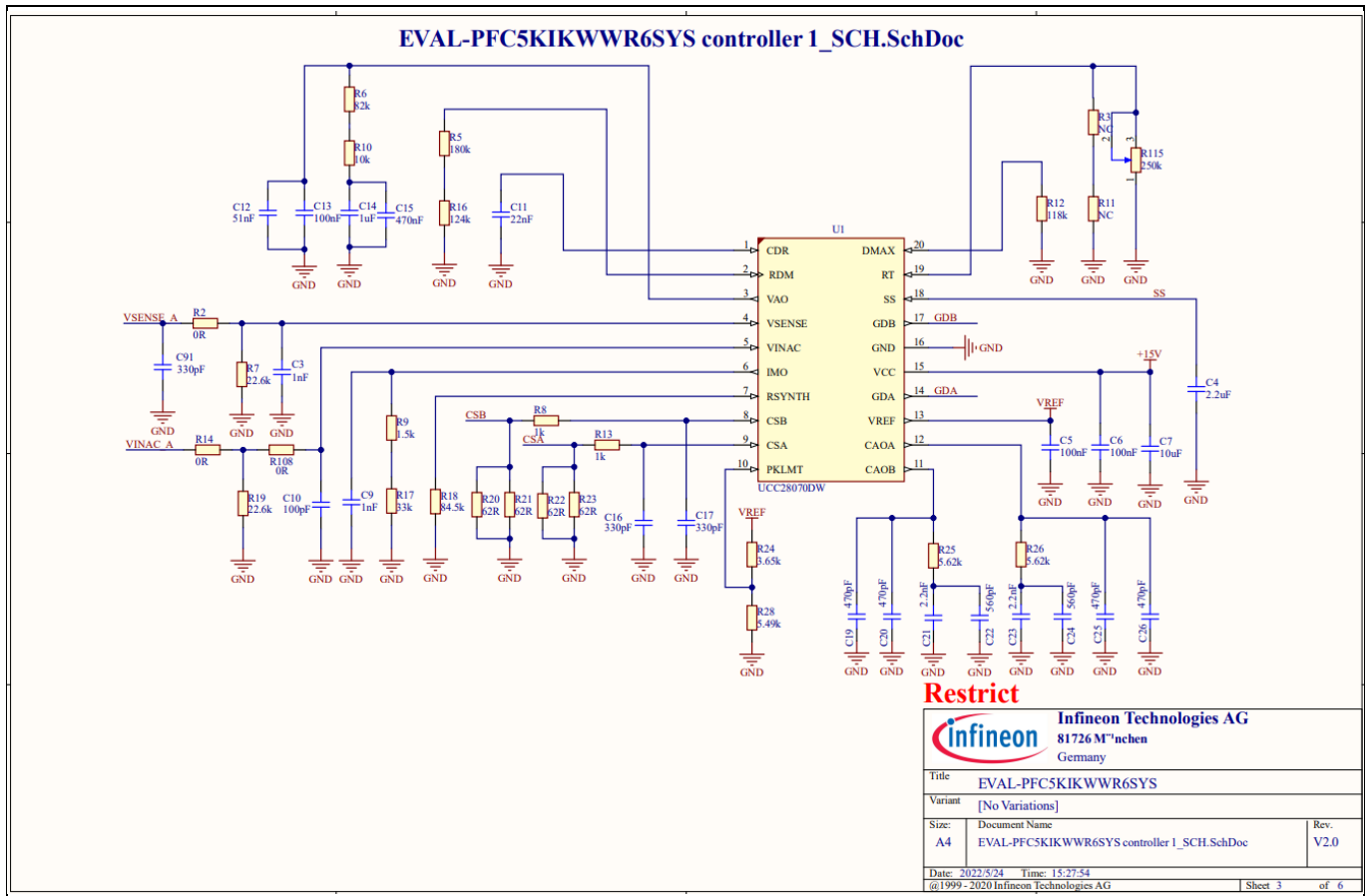

Figure 8 UCC28070 parameter settings for EVAL-PFC5KIKWWR6SYS

Great care was taken to select the proper value for the RC filters applied to V_{SENSE} and V_{IN-AC} because it is important to avoid the destabilizing effects of excess noise on these inputs in a noisy environment. If applied, the RC time-constant for these two pins should not exceed 100 μ s. More information on how to control the UCC28070 with external components can be found in [1].

Figure 9 shows the fault protection provided in EVAL-PFC5KIKWWR6SYS. Thermal shutdown of the power semiconductors is implemented by an external comparator. If the cooling fans fixed on the mechanical box do not work or fail, resistance of the NTC fixed on the heat sink decreases dramatically and the SS pin of UCC28070 is pulled down to ground, in which case both gate signals are disabled.

5 kW two-channel interleaved CCM PFC EVAL board

IKWH40N65WR6, IDW60C65D1 and 1ED44175 in high frequency PFC application



System design

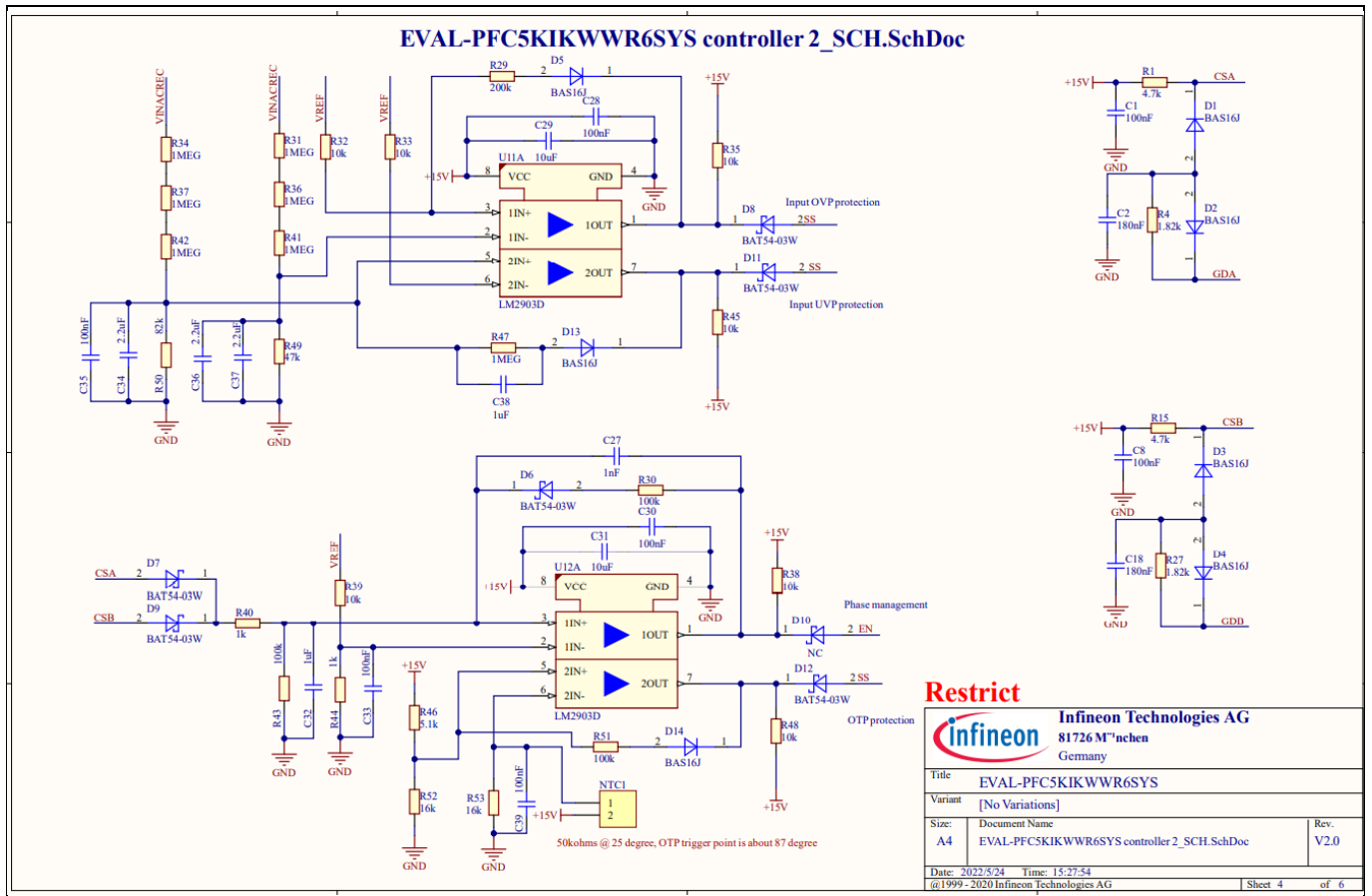

Figure 9 Protections of EVAL-PFC5KIKWWR6SYS

As the UCC28070 already has an integrated output-overvoltage protection through the continuous monitoring of V_{VSENSE} , the input over voltage and under voltage protection in this converter are implemented by external comparators. The outputs of these comparators are connected to the SS pin of UCC28070.

5 kW two-channel interleaved CCM PFC EVAL board IKWH40N65WR6, IDW60C65D1 and 1ED44175 in high frequency PFC application



System design

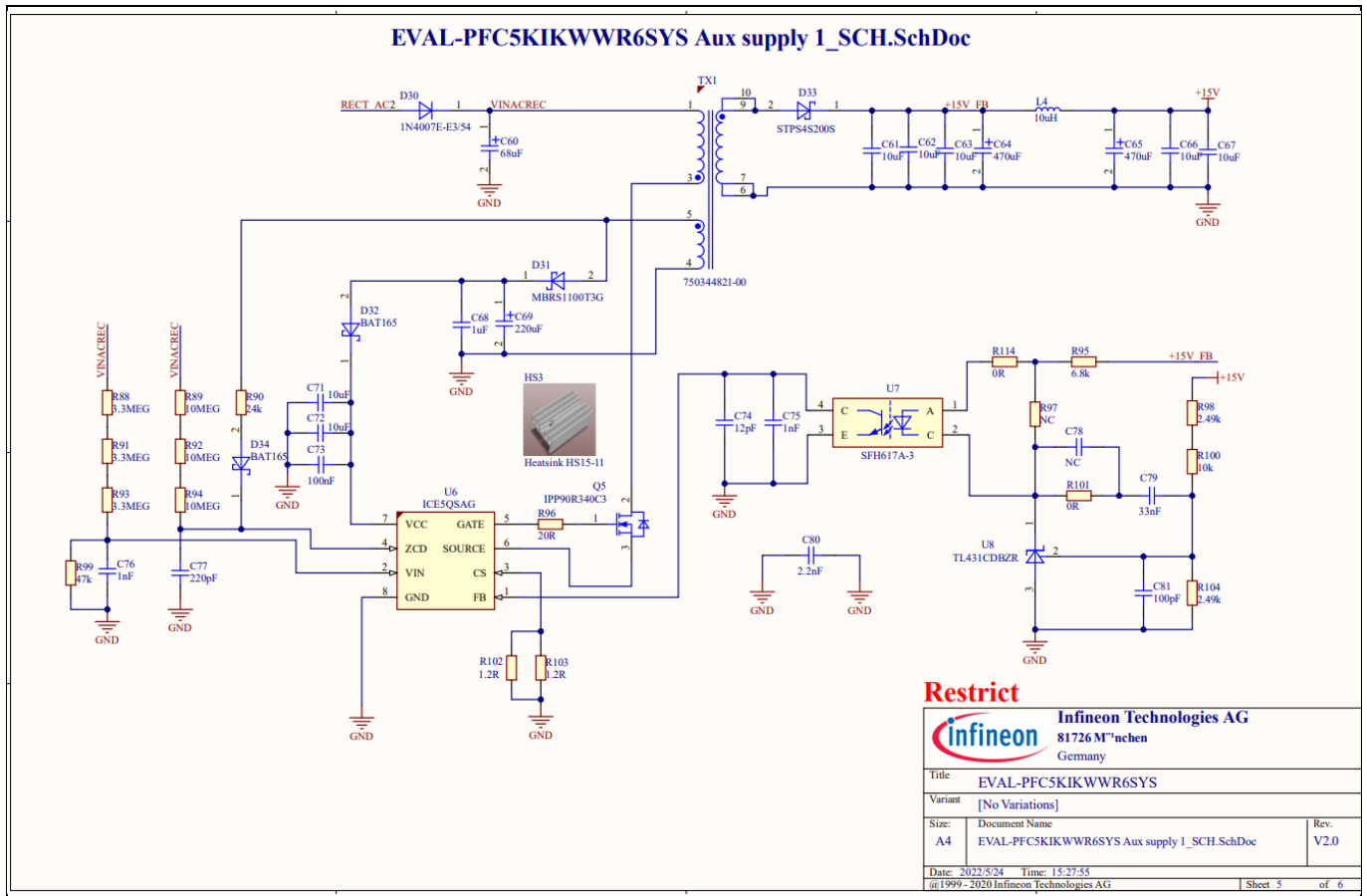

Figure 10 Auxiliary supply of EVAL-PFC5KIKWWR6SYS

Figure 10 shows the auxiliary supply of EVAL-PFC5KIKWWR6SYS supplying voltage to the controller circuit, gate drivers, and cooling fans. ICE5QSAG [2] is a QR mode controller for soft-switching operation of Q5, it helps increase system efficiency. To simplify the design of the Flyback transformer (TX1 in Figure 10), only one secondary winding is used with an output voltage of 15 V, which is an optimized voltage for driving IGBTs.

The maximum recommended voltage for cooling fans is 13.8 V, therefore, as shown in Figure 11, two low dropout (LDO) linear voltage regulator ICs IFX1963 provide about 13.6 V voltage to the fans directly, without regulating the fan speed.

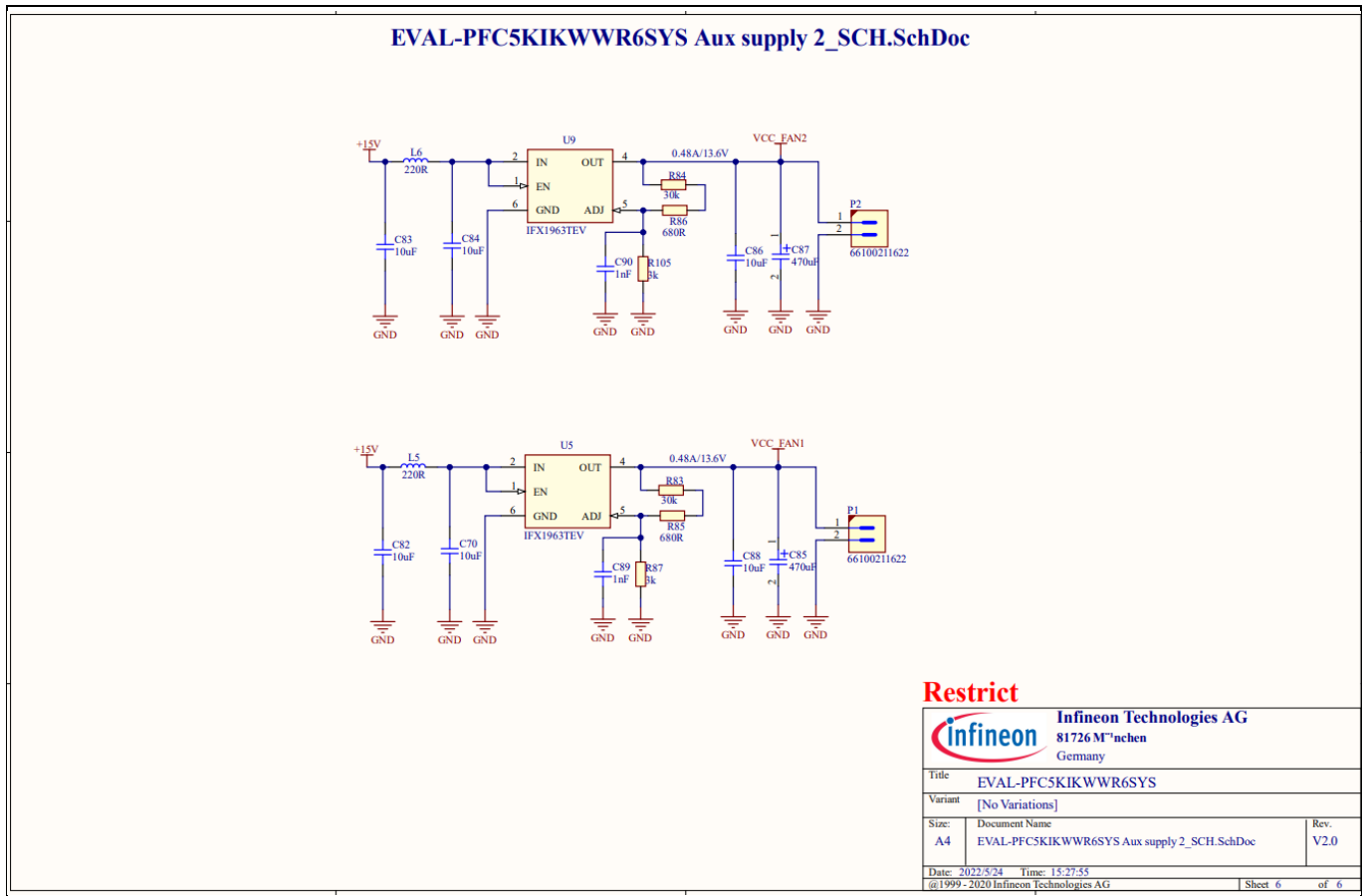

Figure 11 Low-dropout regulators for fans of EVAL-PFC5KIKWWR6SYS

3.2 Layout

The layout of this evaluation board can help customers understand the placements of components and the routing of wires on the whole board. The PCB, by default, is 244 mm × 142 mm in dimension and has four electrical layers with 70 μm of copper. The thickness of the PCB board is 2 mm. Please check Infineon’s website or contact Infineon’s technical support team for more information and the latest Gerber files.

5 kW two-channel interleaved CCM PFC EVAL board

IKWH40N65WR6, IDW60C65D1 and 1ED44175 in high frequency PFC application



System design

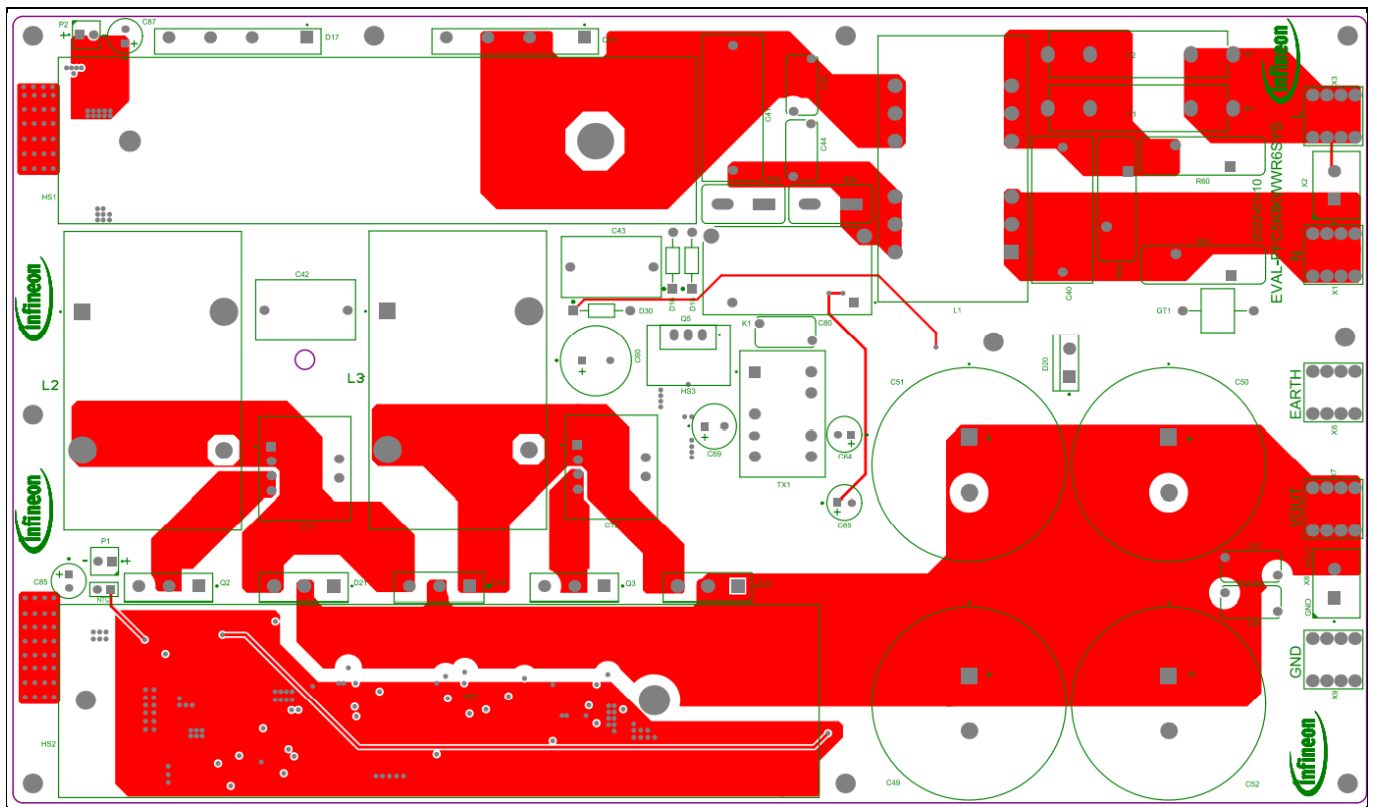

Figure 12 Top layer routing of EVAL-PFC5KIKWWR6SYS

Figure 12 shows the top layer routing of the evaluation board.

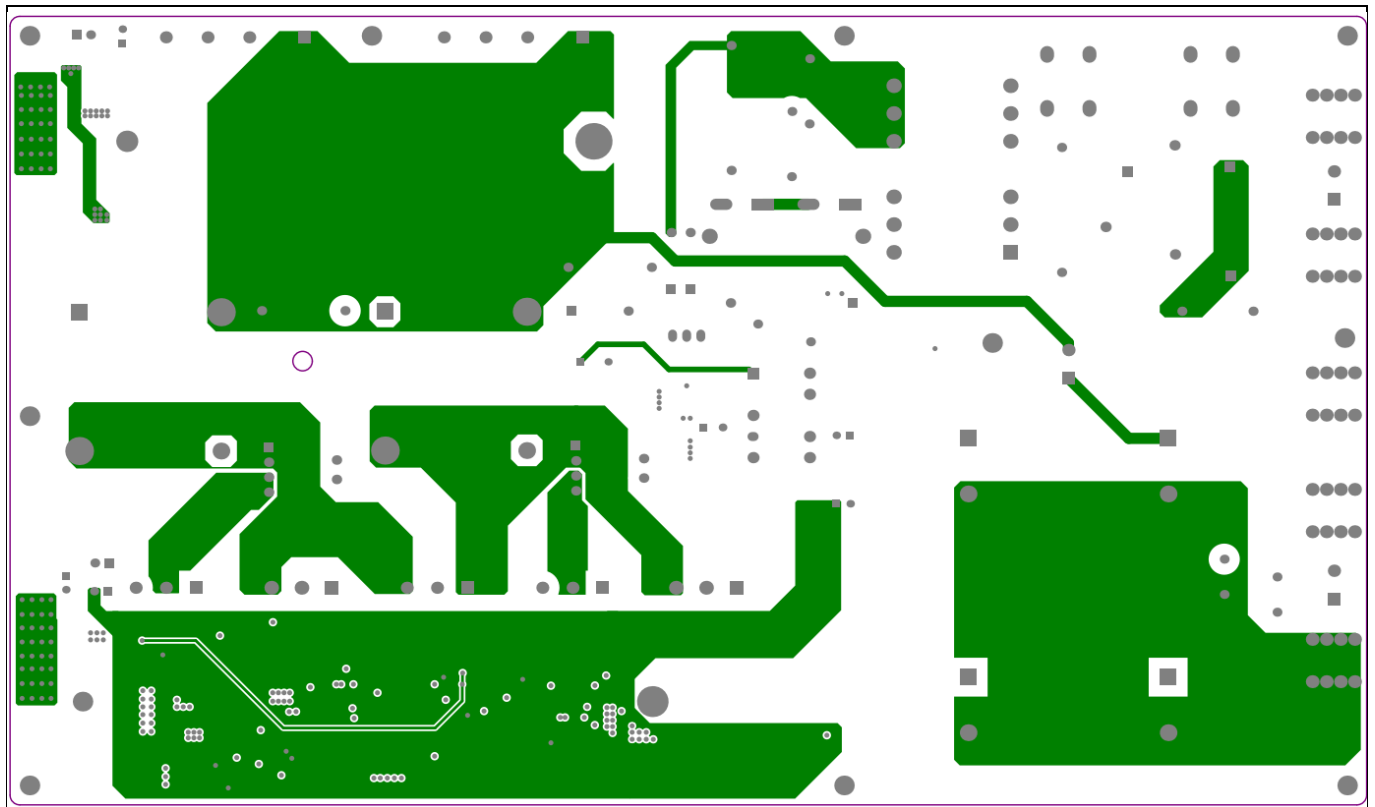

Figure 13 Mid layer 1 routing of EVAL-PFC5KIKWWR6SYS

System design

Figure 13 shows the mid layer 1 routing of the evaluation board.

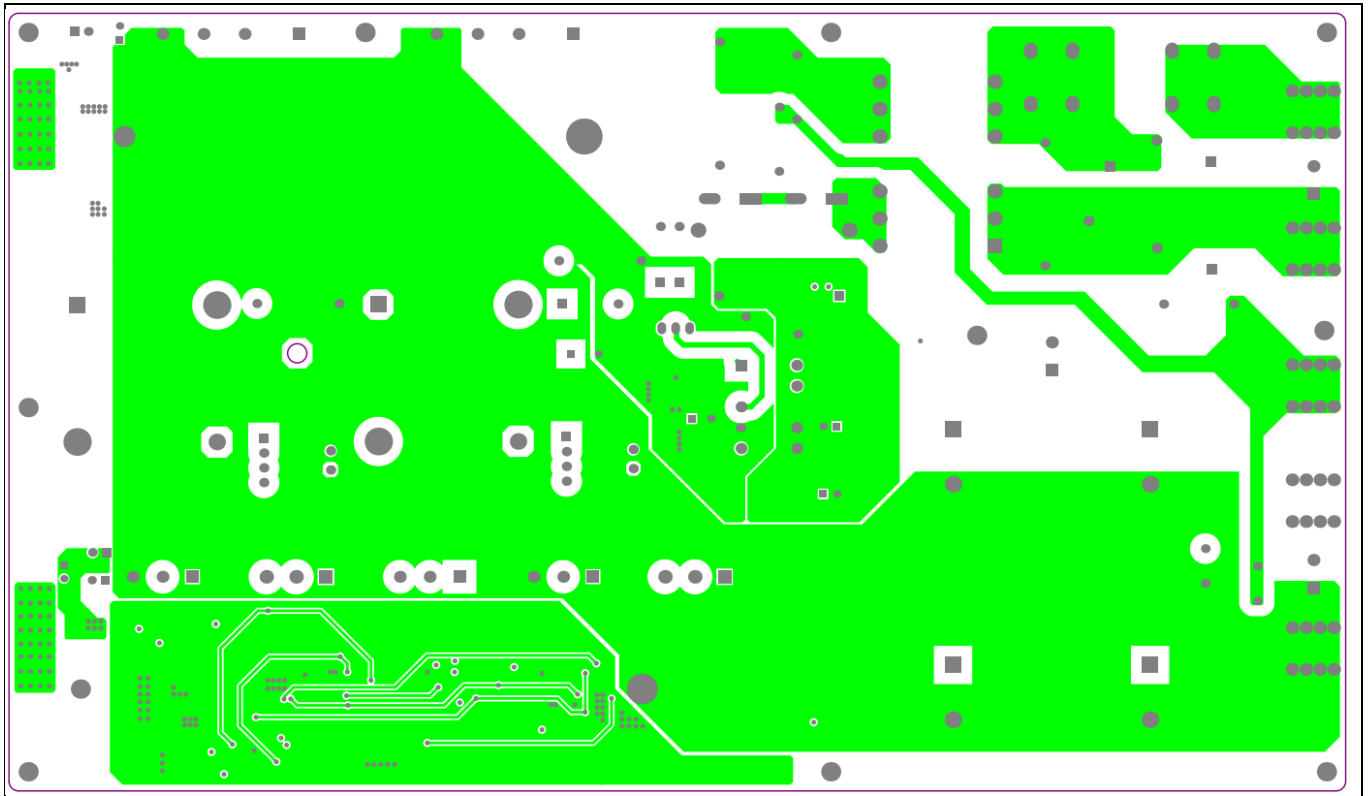

Figure 14 Mid layer 2 routing of EVAL-PFC5KIKWWR6SYS

Figure 14 shows the mid layer 2 routing of the evaluation board.

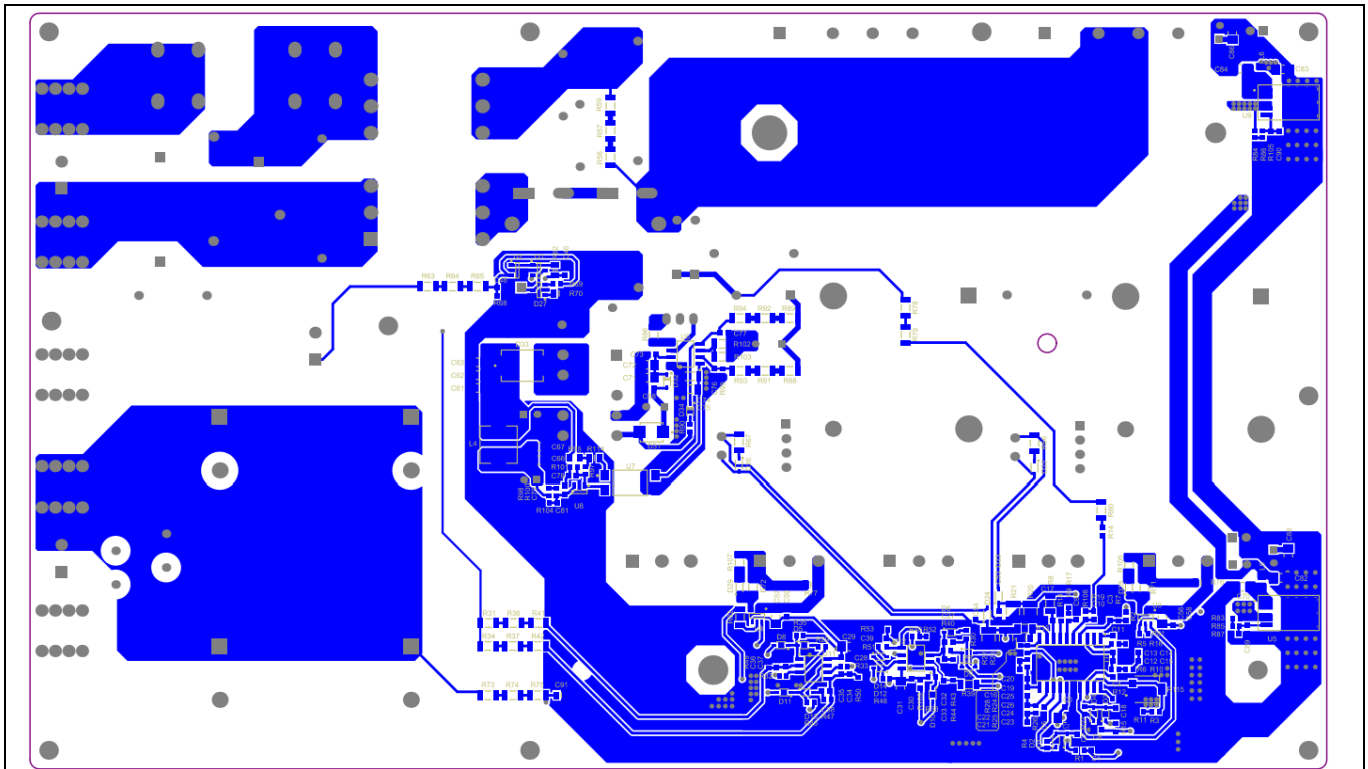

Figure 15 Bottom layer routing of EVAL-PFC5KIKWWR6SYS

5 kW two-channel interleaved CCM PFC EVAL board

IKWH40N65WR6, IDW60C65D1 and 1ED44175 in high frequency PFC application



System design

Figure 15 shows the bottom layer routing of the evaluation board.

3.3 Bill of material

The complete bill of material is available in the Download section of Infineon's homepage. A login is required to download this material.

Table 3 BOM of evaluation board

Quantity	Ref designator	Value	Description	Manufacturer	Manufacturer P/N
15	C1, C5, C6, C8, C13, C28, C30, C33, C35, C39, C46, C48, C58, C59, C73	100nF	Chip Monolithic Ceramic Capacitor	MuRata	GRM188R71E104KA01,
2	C2, C18	180nF	Chip Monolithic Ceramic Capacitor	MuRata	GCM188R71E184JA55
6	C3, C9, C27, C76, C89, C90	1nF	Chip Monolithic Ceramic Capacitor	MuRata	GRM188R71E102KA01,
4	C4, C34, C36, C37	2.2uF	Chip Monolithic Ceramic Capacitor	MuRata	GRM188R61E225KA12
18	C7, C29, C31, C56, C57, C61, C62, C63, C66, C67, C70, C71, C72, C82, C83, C84, C86, C88	10uF	Commercial Grade Multilayer Ceramic Chip Capacitor	TDK Corporation	C3216X7R1E106K160AB
2	C10, C81	100pF	Multilayer Ceramic Chip Capacitor, C Series, Commercial Grade, General	TDK Corporation	C1608X7R1H101M
1	C11	22nF	Chip Monolithic Ceramic Capacitor	Kemet	C0603C223K5RACTU
2	C21, C23	2.2nF	Chip Monolithic Ceramic Capacitor	MuRata	GRM188R71E222KA01
1	C12	51nF	Chip Monolithic Ceramic Capacitor	MuRata	GCM188R71E473KA37
4	C14, C32, C38, C68	1uF	Chip Monolithic Ceramic Capacitor	MuRata	GRM188R71E105KA12
1	C15	470nF	Chip Monolithic Ceramic Capacitor	MuRata	GRM188R71C474KA88
2	C16, C91	330pF	Chip Monolithic Ceramic Capacitor	MuRata	GRM216R71H331KA01
3	C17, C53, C54	330pF	Chip Monolithic Ceramic Capacitor	MuRata	GRM188R71H331KA01
4	C19, C20, C25, C26	470pF	Chip Monolithic Ceramic Capacitor	MuRata	GRM188R71H471KA01
2	C22, C24	560pF	Chip Monolithic Ceramic Capacitor	MuRata	GRM1885C1E561JA01
2	C40, C41	1uF	Metallized Polypropylene Film Capacitor	TDK Corporation	B32923C3105M000
1	C42	1uF	Metallized Polyester Film Capacitor	Epcos	B32522N6105K000
1	C43	NC	Metallized Polyester Film Capacitor	Epcos	B32522N6105K000
5	C44, C45, C47, C55, C80	2.2nF	AC Line Rated Ceramic Disc Capacitor Class X1, 760 VAC / Class Y1, 500 VAC	Vishay	440LD22-R
4	C49, C50, C51, C52	680uF	CAP / ELCO / 680uF / 450V / 20% / - / -40°C to 105°C / 10.00mm Pitch X 35.00mm Dia X 62.00 mm H body / - / -	Aishi	ELP2WM681R60KT
1	C60	68uF	Miniature Aluminum Electrolytic Capacitor	Aishi	EHL2WM680W50OT

5 kW two-channel interleaved CCM PFC EVAL board

IKWH40N65WR6, IDW60C65D1 and 1ED44175 in high frequency PFC application



System design

Quantity	Ref designator	Value	Description	Manufacturer	Manufacturer P/N
4	C64, C65, C85, C87	470uF	Aluminum Electrolytic Capacitor / FC Series	Aishi	SPD1CM102G12O00RAXX X
1	C69	220uF	Miniature Aluminum Electrolytic Capacitor	Aishi	EML1EM221F090T
1	C74	12pF	Chip Monolithic Ceramic Capacitor	MuRata	GRM31A5C2H120JW01
1	C75	1nF	Chip Monolithic Ceramic Capacitor	MuRata	GRM319R71H102JA01
1	C77	220pF	Chip Monolithic Ceramic Capacitor	MuRata	GRM188R71H221KA01
1	C78	NC	Multilayer Ceramic Chip Capacitor, C Series, Commercial Grade, General	TDK Corporation	C1608X7R1H101M
1	C79	33nF	Chip Monolithic Ceramic Capacitor	MuRata	GRM188R71E333JA01
2	CT1, CT2	750344822-00	Transformer, 10.50mH, Turn Ratio 400:1	Würth Elektronik	750344822-00
13	D1, D2, D3, D4, D5, D13, D14, D23, D24, D25, D26, D28, D29	BAS16J	Silicon Switching Diode	Nexperia	BAS16J
6	D6, D7, D8, D9, D11, D12	BAT54-03W	Silicon Schottky Diode	Infineon Technologies	BAT54-03W
1	D10	NC	Silicon Schottky Diode	Infineon Technologies	BAT54-03W
3	D15, D16, D30	1N4007E-E3/54	General Purpose Plastic Rectifier	Vishay	1N4007E-E3/54
2	D17, D18	GBJ2508-F	Glass Passivated Bridge Rectifier 600V	Micro Commercial Components	GBJ2508-F
1	D19	IDW60C65D1	650 V rapid 1 Diode, IF 30/60A, TO247-3	Infineon Technologies	IDW60C65D1
1	D20	STTH10LCD06FP	Turbo2 Ultrafast High Voltage Rectifier For Flat Panel Displays	STMicroelectronics	STTH10LCD06FP
2	D21, D22	NC	650 V rapid 1 Diode, 30A, TO247-3	Infineon Technologies	IDW30E65D1
1	D27	BAV99	High-Speed Switching Diode	Nexperia	BAV99
1	D31	MBRS1100T3G	Schottky Power Rectifier	ON Semiconductor	MBRS1100T3G
2	D32, D34	BAT165	Medium Power AF Schottky Diode	Infineon Technologies	BAT165
1	D33	STPS4S200S	Surface Mount Schottky Barrier Rectifier	STMicroelectronics	STPS4S200S
2	F1, F2	12.8mR	Fast-Acting Fuse Cartridge, 20A/250V	Conquer	ABE 020
1	GT1	2049-60-BLF	RES / STD / - / - / 30% / - / -30°C to 85°C / 12.80mm pitch, 6.00 mm L X 8.00 mm W, 8.3 mm H body / - / -	Bourns	2049-60-BLF
1	HS1	Heatsink L115mm*W30mm*H50mm	Heatsink L115mm*W30mm*H50mm	-	Heatsink L115mm*W30mm*H50mm
1	HS2	Heatsink L137mm*W35mm*H60mm	Heatsink L137mm*W35mm*H60mm	-	Heatsink L137mm*W35mm*H60mm
1	HS3	Heatsink HS15-11	Heatsink L15*W11	-	Heatsink HS15-11
1	K1	HF161F-W/18-HT	Solar Relay, Applicable to inverter used for photovoltaic power generation systems	HongFa	HF161F-W/18-HT
1	L1	1.5mH	Common Mode Power Line Choke	Würth Elektronik	7448063801
2	L2, L3	85uH	IND / STD / 85uH / - / 10% / - / 16mR / THT / Inductor, THT, 4 pin, 54.00 mm L X 32.00 mm	POCO	PI200273V1

5 kW two-channel interleaved CCM PFC EVAL board

IKWH40N65WR6, IDW60C65D1 and 1ED44175 in high frequency PFC application



System design

Quantity	Ref designator	Value	Description	Manufacturer	Manufacturer P/N
			W X 56.00 mm H body / THT / -		
1	L4	10uH	IND / STD / 10uH / 4A / 20% / -40°C to 150°C / 33mR / SMD / Inductor, SMD, 6.90mm L X 6.90mm W X 5.00mm H body / SMD / -	Würth Elektronik	744314101
2	L5, L6	220R	Chip Ferrite Bead	Würth Elektronik	742792031
1	NTC1	AYN-MF56-503F-3950FB-28#-100	Header, 2-Pin		AYN-MF56-503F-3950FB-28#-100
2	P1, P2	66100211622	CONNECTOR HEADER VERT 2POS 2.54MM	Würth Elektronik	66100211622
1	Q1	IRLML6402TRPBF	HEXFET P-Channel Power MOSFET, 20V, 3.7A	Infineon Technologies	IRLML6402TRPBF
2	Q2, Q3	IKWH40N65WR6	High speed fast IGBT in TRENCHSTOP™ 5 technology, VCE 650V, IC 40A	Infineon Technologies	IKWH40N65WR6
1	Q5	IPP90R340C3	900V CoolMOS C3 Power Transistor, RDS(on) 340mOhm	Infineon Technologies	IPP90R340C3
3	R1, R15, R81	4.7k	General Purpose Chip Resistor	Yageo	RC0603FR-074K7L
4	R2, R14, R108, R109	0R	0R/75V	Panasonic	ERJ3GEY0R00V
1	R3	NC	Standard Thick Film Chip Resistor	Vishay	CRCW0603115KFK,
1	R11	NC	Standard Thick Film Chip Resistor	Vishay	CRCW060310K0FK
1	R97	NC	Standard Thick Film Chip Resistor	Vishay	CRCW06031K20FK
2	R4, R27	1.82k	Standard Thick Film Chip Resistor	Vishay	CRCW06031K82FK
1	R5	180K	Standard Thick Film Chip Resistor	Vishay	CRCW0603180KFK
2	R6, R50	82k	Standard Thick Film Chip Resistor	Vishay	CRCW060382K0FK
2	R7, R19	22.6k	Standard Thick Film Chip Resistor	Vishay	CRCW060322K6FK
3	R8, R66, R67	1k	Standard Thick Film Chip Resistor	Vishay	CRCW12061K00FK
1	R9	1.5k	Standard Thick Film Chip Resistor	Vishay	CRCW06031K50FK
8	R10, R32, R33, R35, R38, R45, R48, R100	10k	Standard Thick Film Chip Resistor	Vishay	CRCW060310K0FK
1	R12	118k	Standard Thick Film Chip Resistor	Vishay	CRCW0603118KFK
1	R13	1k	1k/200V/1%	TT Electronics	ASC1206-1K0FT5
1	R16	124k	Standard Thick Film Chip Resistor	Vishay	CRCW0603124KFK
1	R17	33k	Standard Thick Film Chip Resistor	Vishay	CRCW060333K0FK
1	R18	84.5k	Standard Thick Film Chip Resistor	Vishay	CRCW060384K5FK
4	R20, R21, R22, R23	62R	Standard Thick Film Chip Resistor	Vishay	CRCW121062R0FK
1	R24	3.65k	Standard Thick Film Chip Resistor	Vishay	CRCW06033K65FK
2	R25, R26	5.62k	Standard Thick Film Chip Resistor	Vishay	CRCW06035K62FK
1	R28	5.49k	Standard Thick Film Chip Resistor	Vishay	CRCW06035K49FK
1	R29	200k	Standard Thick Film Chip Resistor	Vishay	CRCW0603200KFK
3	R30, R43, R51	100k	General Purpose Chip Resistor	Yageo	RC0603FR-07100KL

5 kW two-channel interleaved CCM PFC EVAL board
IKWH40N65WR6, IDW60C65D1 and 1ED44175 in high frequency PFC application



System design

Quantity	Ref designator	Value	Description	Manufacturer	Manufacturer P/N
18	R31, R34, R36, R37, R41, R42, R56, R57, R59, R63, R64, R65, R73, R74, R75, R78, R79, R80	1MEG	Standard Thick Film Chip Resistor	Vishay	CRCW12061M00FK
1	R39	10k	General Purpose Chip Resistor	Yageo	RC1206FR-0710KL
2	R40, R44	1k	Standard Thick Film Chip Resistor	Vishay	CRCW06031K00FK
1	R46	5.1k	Standard Thick Film Chip Resistor	Vishay	CRCW06035K10FK
1	R47	1MEG	Standard Thick Film Chip Resistor	Vishay	CRCW06031M00FK
2	R49, R99	47k	Standard Thick Film Chip Resistor	Vishay	CRCW060347K0FK
2	R52, R53	16k	Standard Thick Film Chip Resistor	Vishay	CRCW060316K0FK
2	R54, R55	10R	NTC Thermistor for Inrush Current Limiting	Epcos	B57237S0100M000
3	R58, R60, R61	275V	Multi Pulse Handling SIOV Metal Oxide Varistor	Epcos	B72220S0271K101
3	R62, R76, R77	4.7k	Standard Thick Film Chip Resistor	Vishay	CRCW08054K70FK
1	R68	33k	33k/50V/1%	ROHM Semiconductors	MCR03ERTF3302
1	R69	470k	Standard Thick Film Chip Resistor	Vishay	CRCW0603470KFK
1	R70	220R	Standard Thick Film Chip Resistor	Vishay	CRCW0805220RFK
2	R71, R72	5.1R	Standard Thick Film Chip Resistor	Vishay	CRCW12065R10FK
1	R82	4.7k	Standard Thick Film Chip Resistor	Vishay	CRCW12064K70FK
2	R83, R84	30k	Standard Thick Film Chip Resistor	Vishay	CRCW060330K0FK
2	R85, R86	680R	Standard Thick Film Chip Resistor	Vishay	CRCW0603680RFK
2	R87, R105	3k	3k/50V/1%	ROHM Semiconductors	MCR03EZPF3001
3	R88, R91, R93	3.3MEG	Standard Thick Film Chip Resistor	Vishay	CRCW12063M30FK
3	R89, R92, R94	10MEG	Standard Thick Film Chip Resistor	Vishay	CRCW120610M0FK
1	R90	24k	Standard Thick Film Chip Resistor	Vishay	CRCW060324K0FK
1	R95	6.8k	General Purpose Chip Resistor	Yageo	RC0805FR-076K8L
1	R96	20R	Standard Thick Film Chip Resistor	Vishay	CRCW120620R0FK
2	R98, R104	2.49k	Standard Thick Film Chip Resistor	Vishay	CRCW06032K49FK
1	R101	0R	Standard Thick Film Chip Resistor	Vishay	CRCW06030000Z0
2	R102, R103	1.2R	Standard Thick Film Chip Resistor	Vishay	CRCW12061R20FK
2	R106, R107	3R	3R/0.5W/1%	Panasonic	ERJ8BQF3R0V
1	R114	0R	Standard Thick Film Chip Resistor	Vishay	CRCW08050000Z0
1	R115	250k	RES / VAR / 250k / 250mW / 20% / 100ppm/K / -55°C to 125°C / 3 pin, 5.00mm L X 4.50mm W X 2.85mm H Body / SMD / -	Bourns	3314G-1-254E
1	TX1	750344821-00	Transformer 10-Terminal EXT, THT, Horizontal, EE Style Bobbins, EE20	Würth Elektronik Midcom	750344821-00
1	U1	UCC28070DW	PFC controller	Texas Instruments	UCC28070DW
2	U2, U8	TL431CDBZR	Precision Programmable Reference	Texas Instruments	TL431CDBZR

5 kW two-channel interleaved CCM PFC EVAL board

IKWH40N65WR6, IDW60C65D1 and 1ED44175 in high frequency PFC application



System design

Quantity	Ref designator	Value	Description	Manufacturer	Manufacturer P/N
2	U3, U4	1ED44175N01B	Gate Drivers LOW SIDE DRIVERS	Infineon Technologies	1ED44175N01B
2	U5, U9	IFX1963TEV	1.5A Low Dropout Linear Voltage Regulator	Infineon Technologies	IFX1963TEV
1	U6	ICE5QSAG	Quasi-Resonant PWM Controller	Infineon Technologies	ICE5QSAG
1	U7	SFH617A-3	Optocoupler, Phototransistor Output, High Reliability, 5300 VRMS, 110 Å°C Rated	Vishay	SFH617A-3
2	U11, U12	LM2903D	Dual differential comparators	Texas Instruments	LM2903D
5	X1, X3, X6, X7, X9	7460307	WP-BUTR Redcube Press Fit with Internal Thread and Two Rows Pin-Plate	Würth Elektronik	7460307
2	X2, X8	691311500102	Terminal Block, 2Pins, 5.08mm Pitch, Board to Cable	Würth Elektronik	691311500102
4	X4, X5	3513	Through Hole 3AG Snap In Fuse Clip	Conquer	CQ-205S
2	FAN1, FAN2	AFB0612EH-ABF00	Cooling fans	Delta	AFB0612EH-ABF00

3.4 Connector details

Table 4 Connectors

PIN	Label	Function
X1	Grid Line	AC input of PFC, connect to grid line
X3	Grid Neutral	AC input of PFC, connect to grid neutral
X6	Earth	Protective earth
X7	PFC DC output	Connect to load positive
X9	PFC Ground	Connect to load negative
X2	Auto test	For AC input auto test
X8	Auto test	For PFC output auto test

System performance

4 System performance

4.1 Efficiency and PFC measurements

All test conditions are based on a 25°C ambient temperature.

For the efficiency test, it is important to monitor the voltage on the input connector X2 and output connector X8, directly.

The efficiency and power factor (PF) measurements are carried out using a WT33E Yokogawa power meter.

Figure 16 shows the overall efficiency of EVAL-PFC5KIKWWR6SYS including the auxiliary supply at different input voltages between 180 V_{AC} and 264 V_{AC}. The efficiency curves show that the WR6 IGBT help customers increase the switching frequency with high system efficiency. The measurements indicate the efficiency at various load conditions up to 5 kW at a switching frequency of 60 kHz.

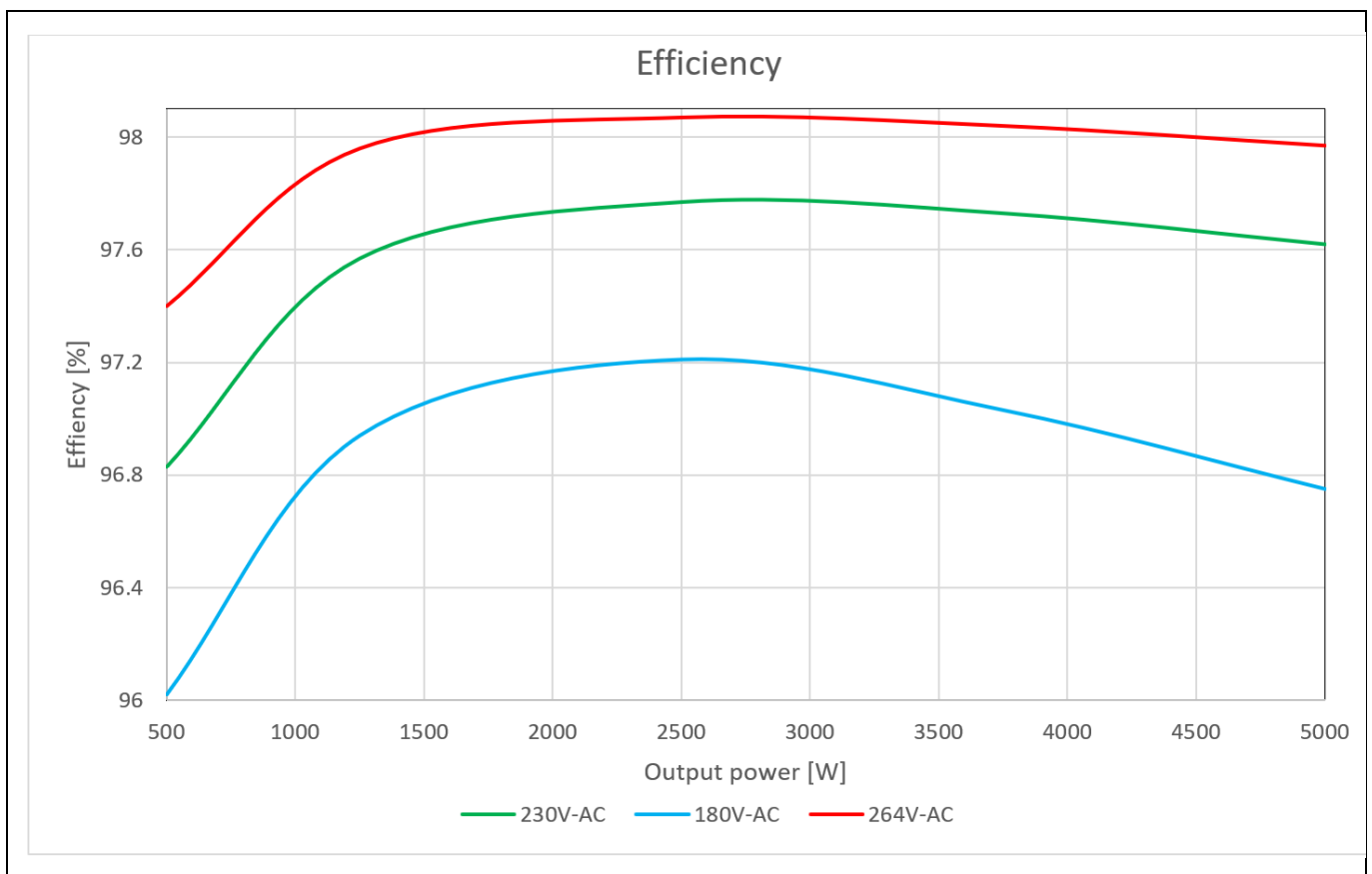

Figure 16 Efficiency of EVAL-PFC5KIKWWR6SYS

Figure 17 shows the power factor curve at different loads and different AC input voltages. As can be seen, even at light loads, the power factor is higher than 0.96. An almost unity power factor is achieved with values higher than 0.99 for loads above 30% of the rated power.

System performance

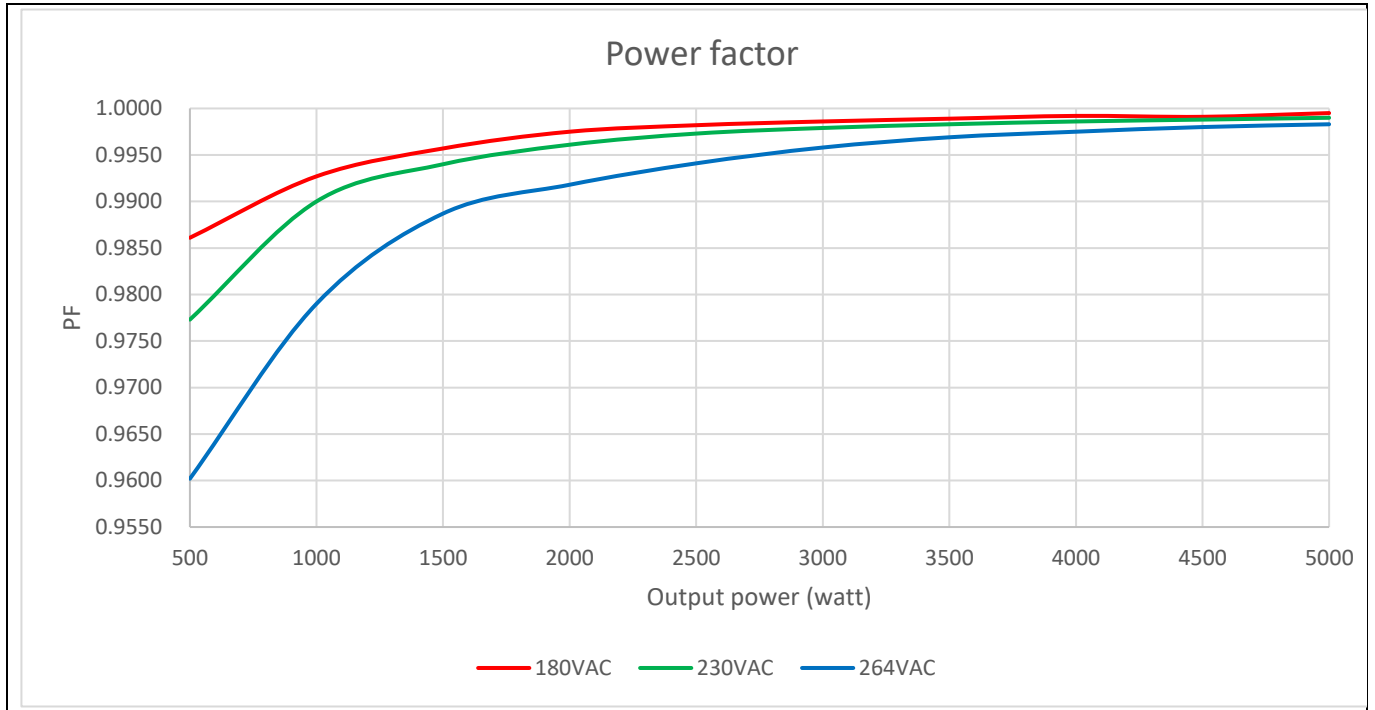

Figure 17 Power factor of EVAL-PFC5KIKWWR6SYS

4.2 Startup behavior

After the evaluation board is connected to a grid, the auxiliary power supply starts up and the devices are supplied with power. During the pre-charging phase of the output capacitor (as seen in Figure 6) both channels are bypassed by the D20—an ultrafast high-voltage rectifier, and the inrush current is limited by the two NTC resistors. After the output voltage reaches about $230 V_{DC}$, the K1 relay turns on and the two NTCs are shorted, thus enabling the converter to work with high efficiency.

EVAL-PFC5KIKWWR6SYS is designed to start in both no load and full load conditions. Figures 18 and 19 show the converter’s full load startup waveforms at $V_{IN} = 180 V_{AC}$ and $V_{IN} = 264 V_{AC}$ respectively.

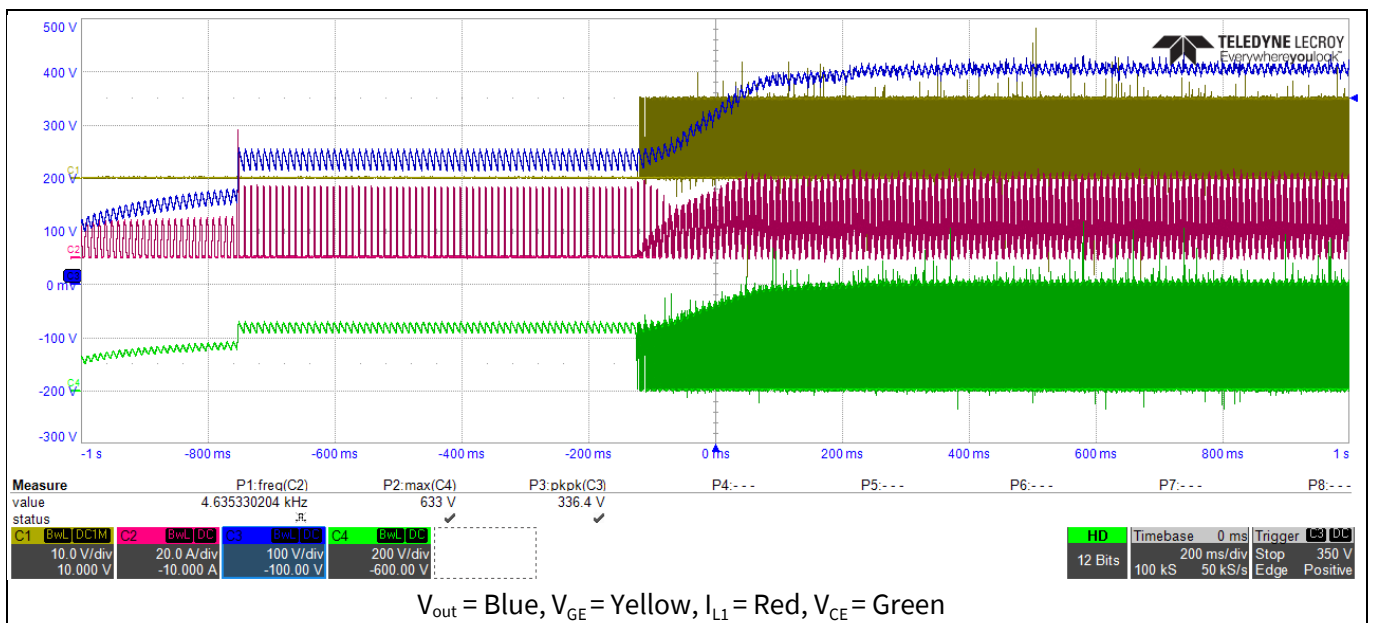

Figure 18 Full load startup at $V_{IN} = 180 V_{AC}$

System performance

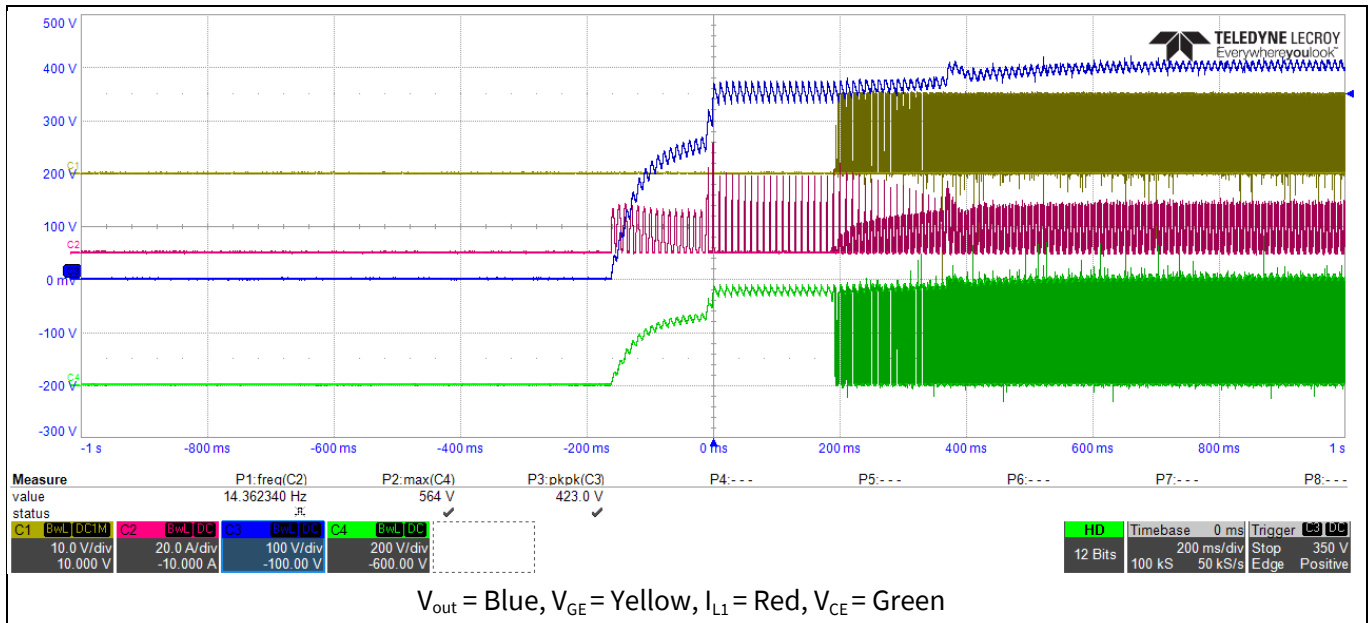

Figure 19 Full load startup at $V_{Inv} = 264 V_{AC}$

4.3 Input current and inductor current cancellation

The next six figures show the waveforms of input AC current and two inductor currents of the converter at full load. The interleaving operation is clear and the two-channel currents are phase shifted by 180° .

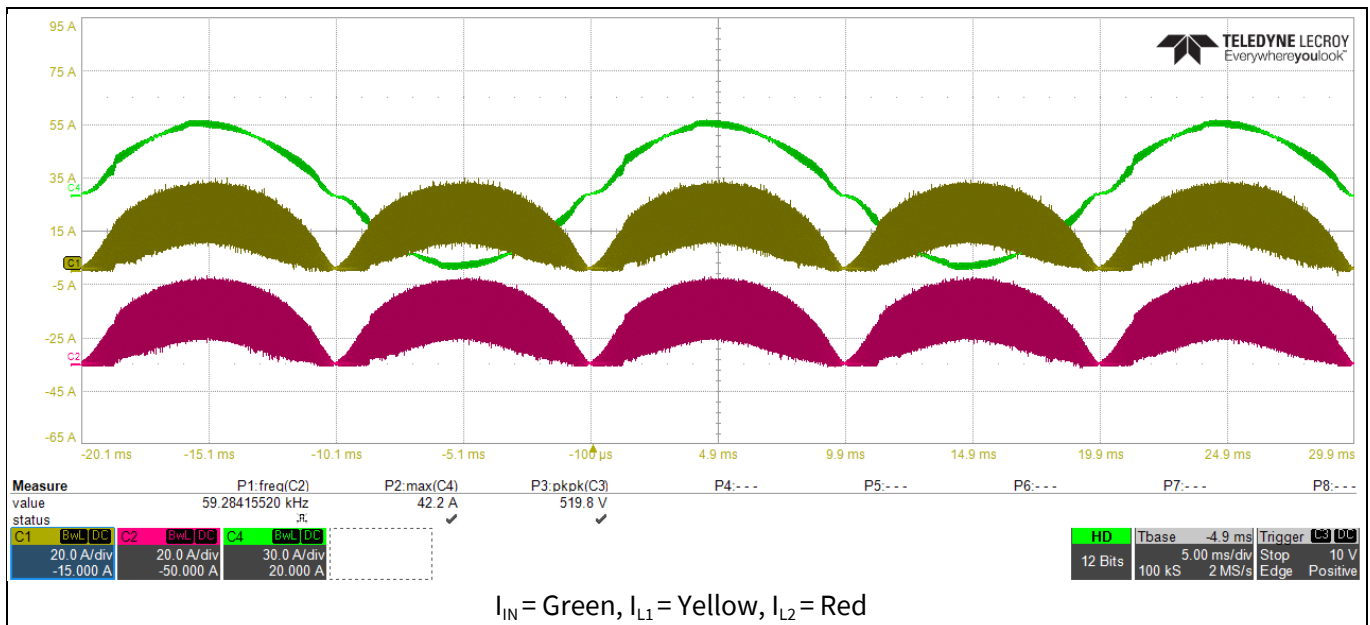

Figure 20 Interleaving operation at full load at $V_{IN} = 180 V_{AC}$

5 kW two-channel interleaved CCM PFC EVAL board

IKWH40N65WR6, IDW60C65D1 and 1ED44175 in high frequency PFC application



System performance

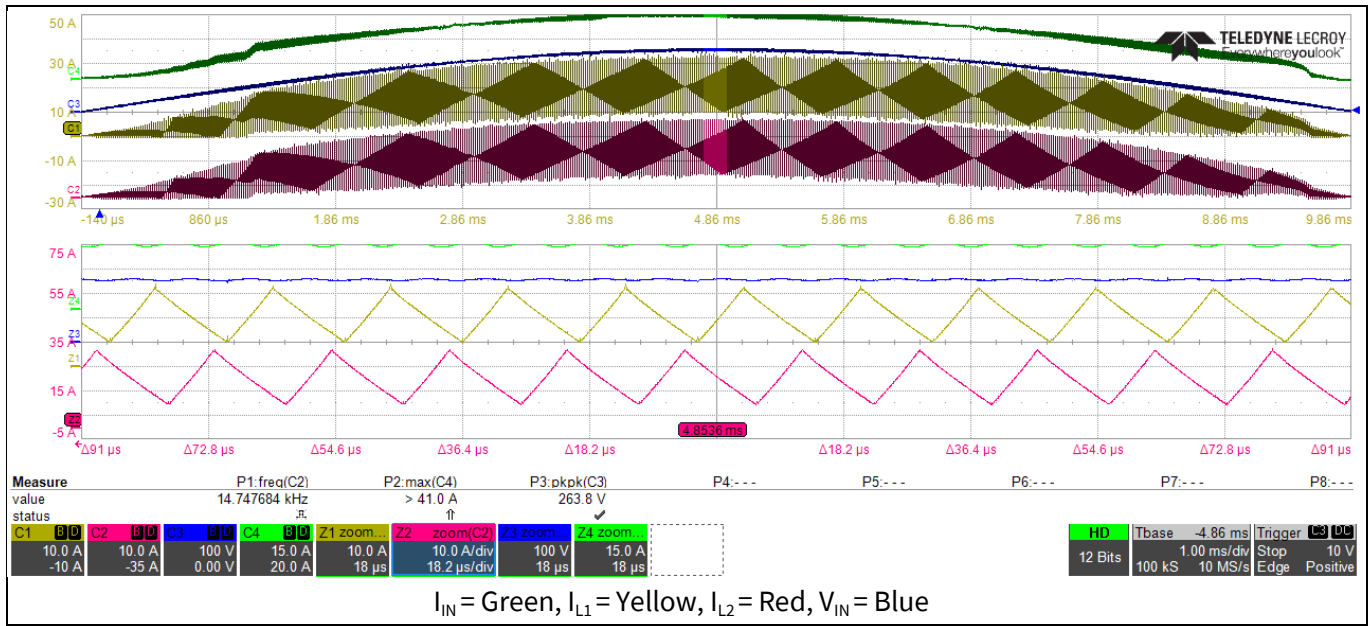

Figure 21 Detailed view of the interleaving operation at full load at $V_{IN} = 180 V_{AC}$

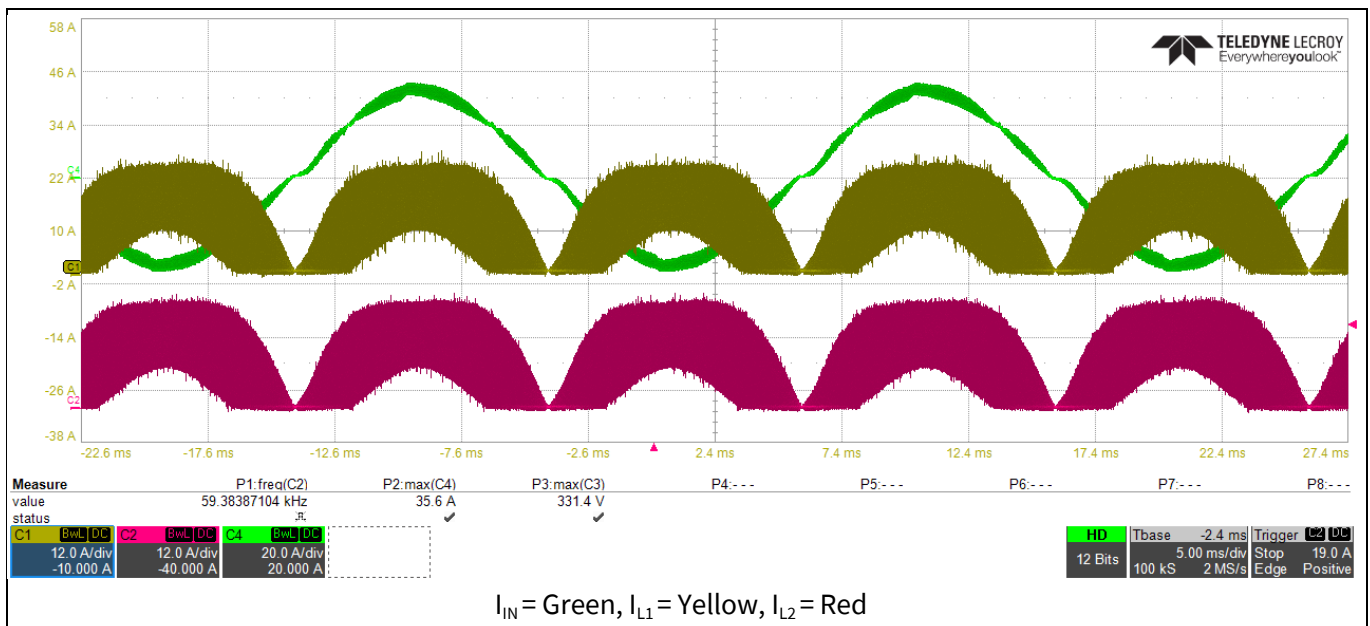

Figure 22 Interleaving operation at full load at $V_{IN} = 230 V_{AC}$

5 kW two-channel interleaved CCM PFC EVAL board

IKWH40N65WR6, IDW60C65D1 and 1ED44175 in high frequency PFC application



System performance

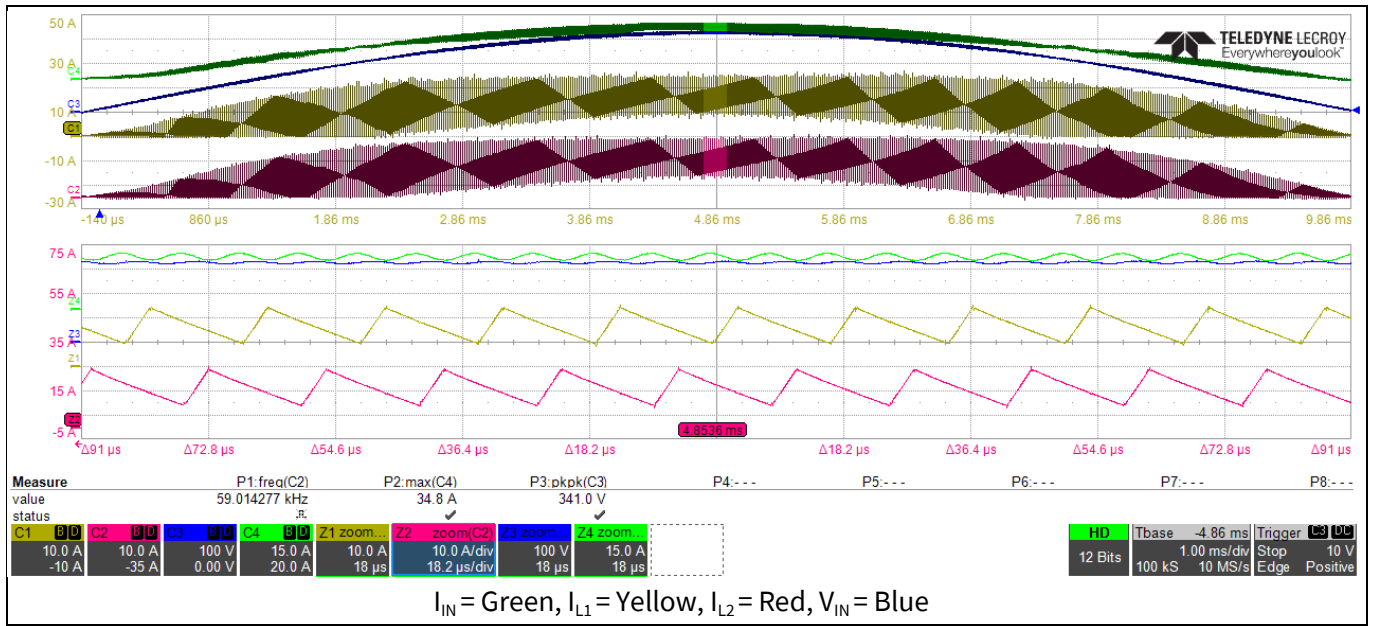

Figure 23 Detailed view of the interleaving operation at full load at V_{IN} = 230 V_{AC}

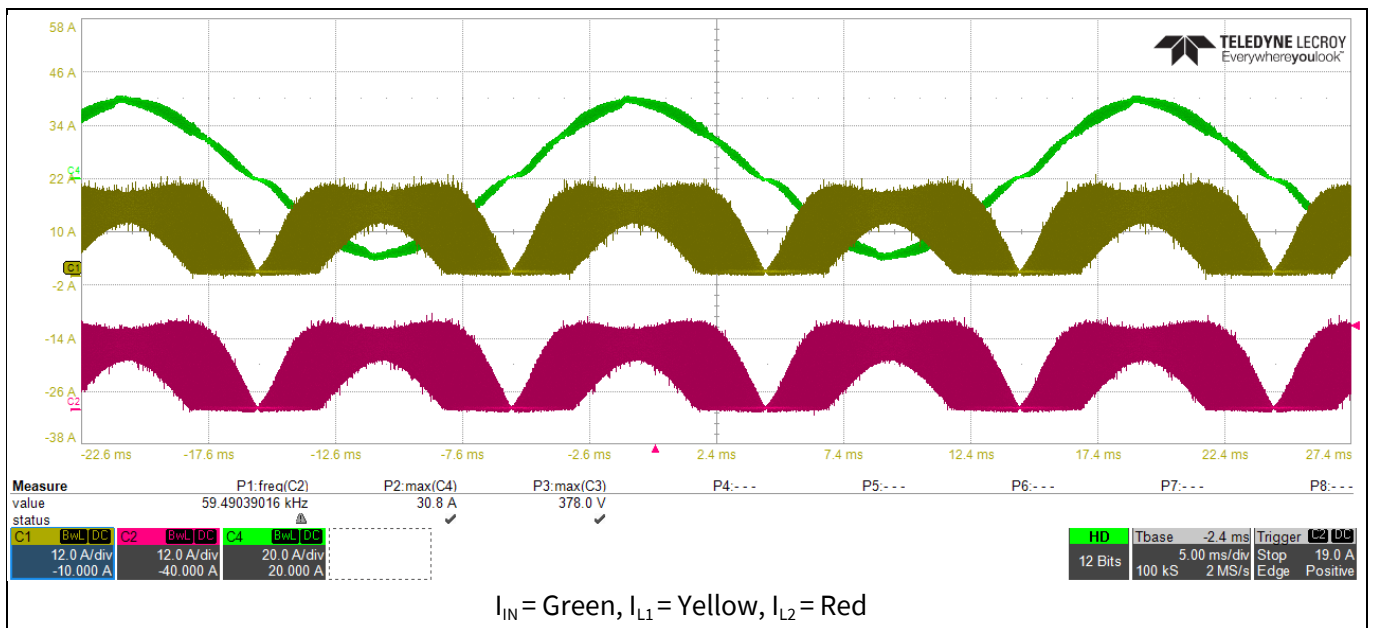

Figure 24 Interleaving operation at full load at V_{IN} = 264 V_{AC}

5 kW two-channel interleaved CCM PFC EVAL board

IKWH40N65WR6, IDW60C65D1 and 1ED44175 in high frequency PFC application

System performance

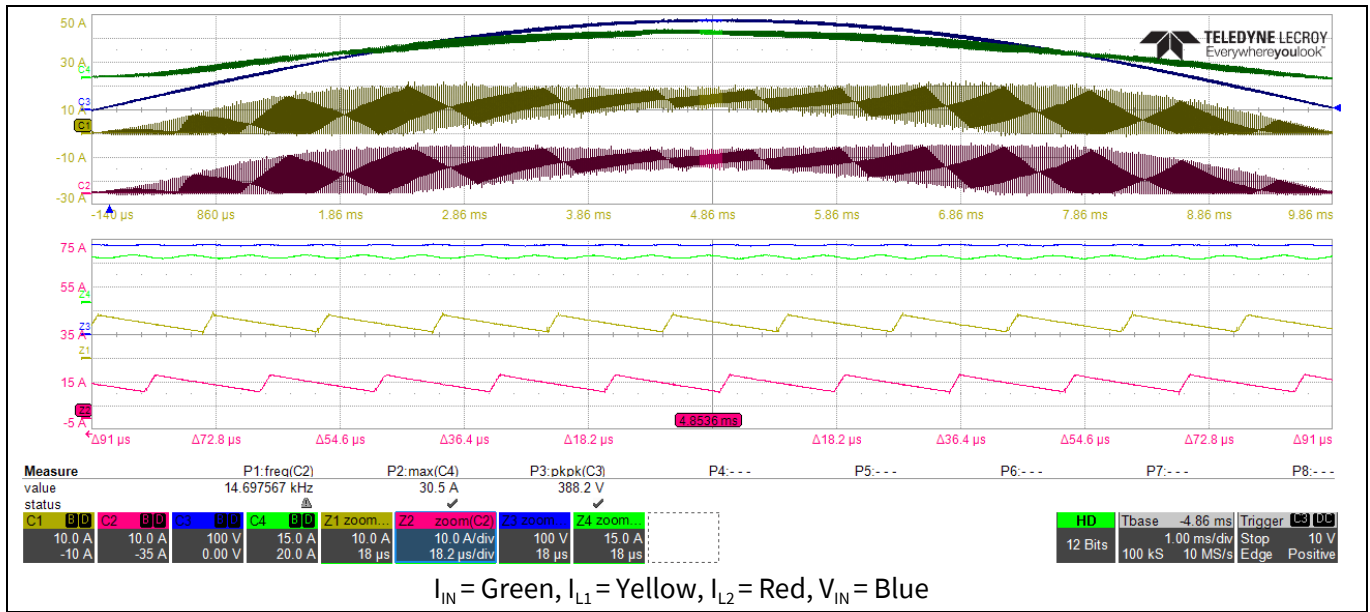

Figure 25 Detailed view of the interleaving operation at full load at $V_{IN} = 264 V_{AC}$

4.4 Switching performance of IGBT at steady state

EVAL-PFC5KIKWWR6SYS is designed to achieve high efficiency by using the 650 V TRENCHSTOP™ 5 WR6 IGBT IKWH40N65WR6 as the main switch in a high-frequency interleaved PFC application. Compared to Infineon’s H3 IGBT, the WR6 IGBT has lower conduction and switching losses. In addition, the Silicon MOSFET can be replaced by a WR6 IGBT in applications with less than 100 kHz switching frequency.

The following three waveforms show the switching performances of IKWH40N65WR6 with the low-side gate driver 1ED44175. In this design, the turn-on gate resistance for each IKWH40N65WR6 is 5.1Ω and the turn-off resistance is 3Ω , considering the driver’s current capability. Smaller gate resistance for turn-on and turn-off helps decrease the turn-on and turn-off loss of the IGBT. However, during the design process, there is always a trade-off between achieving high efficiency and EMI. Customers should put in greater effort to reduce the noise caused by high dv/dt and di/dt in high-frequency applications.

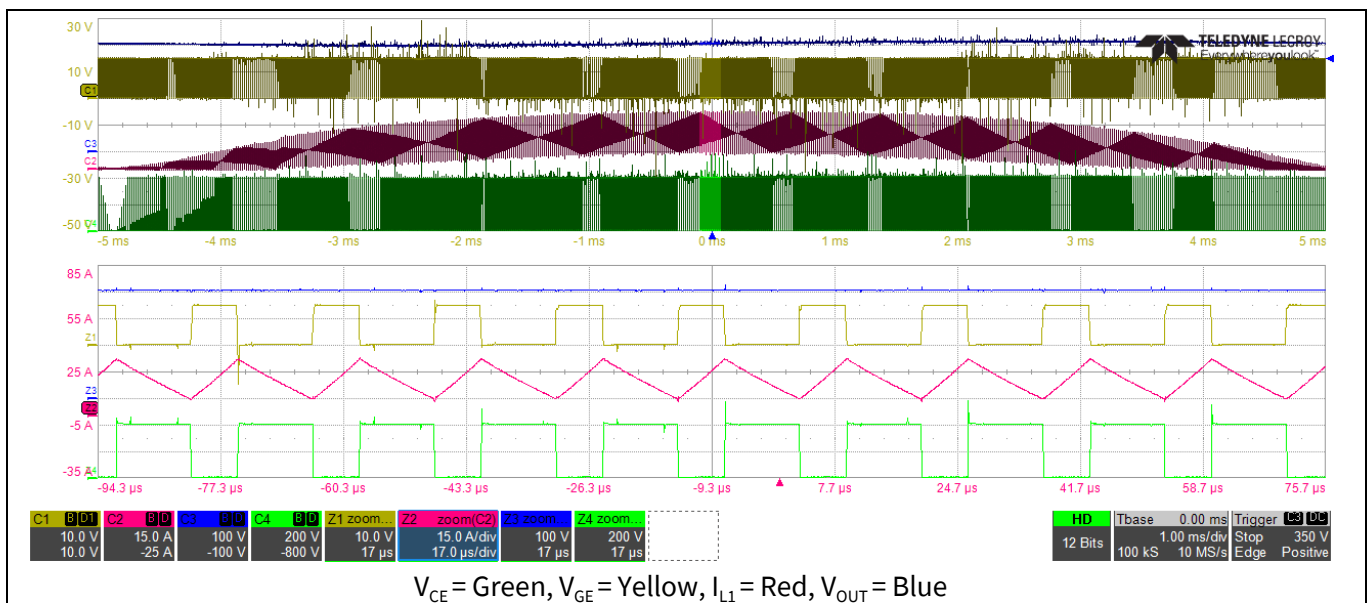

Figure 26 Switching waveforms of the IGBT at $V_{IN} = 180 V_{AC}$ at full load

System performance

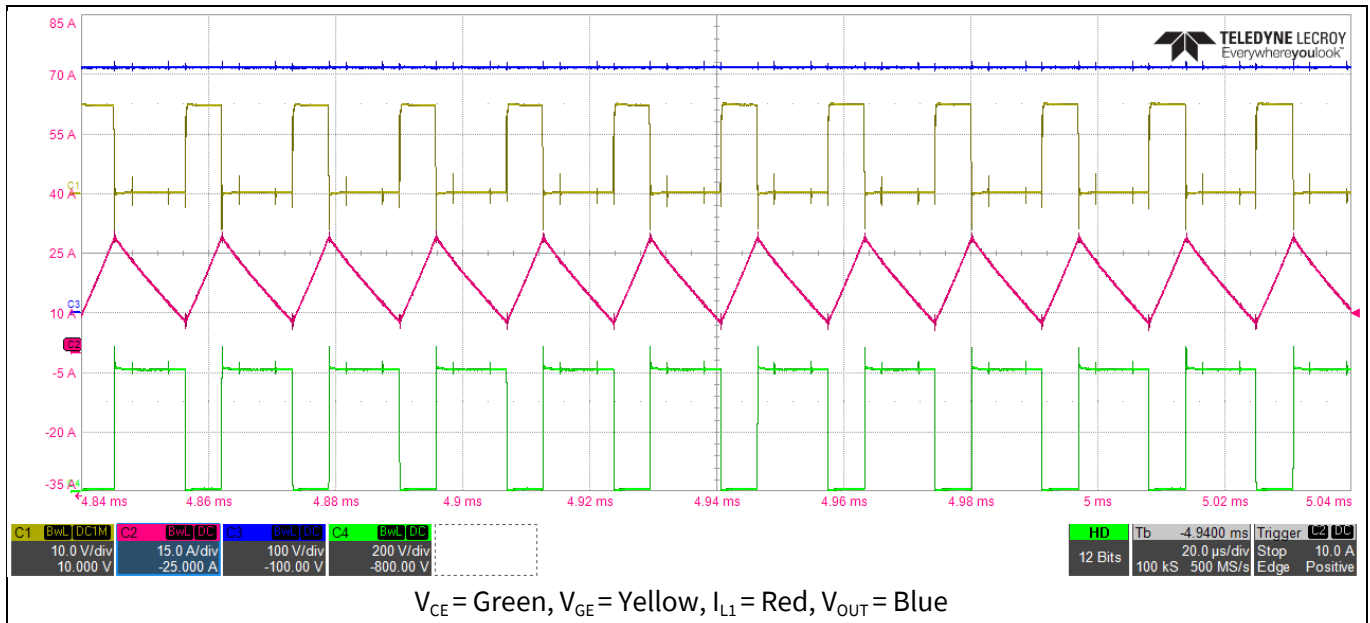

Figure 27 Switching waveforms of the IGBT at $V_{IN} = 200 V_{AC}$ at full load (continuous current around peak AC voltage)

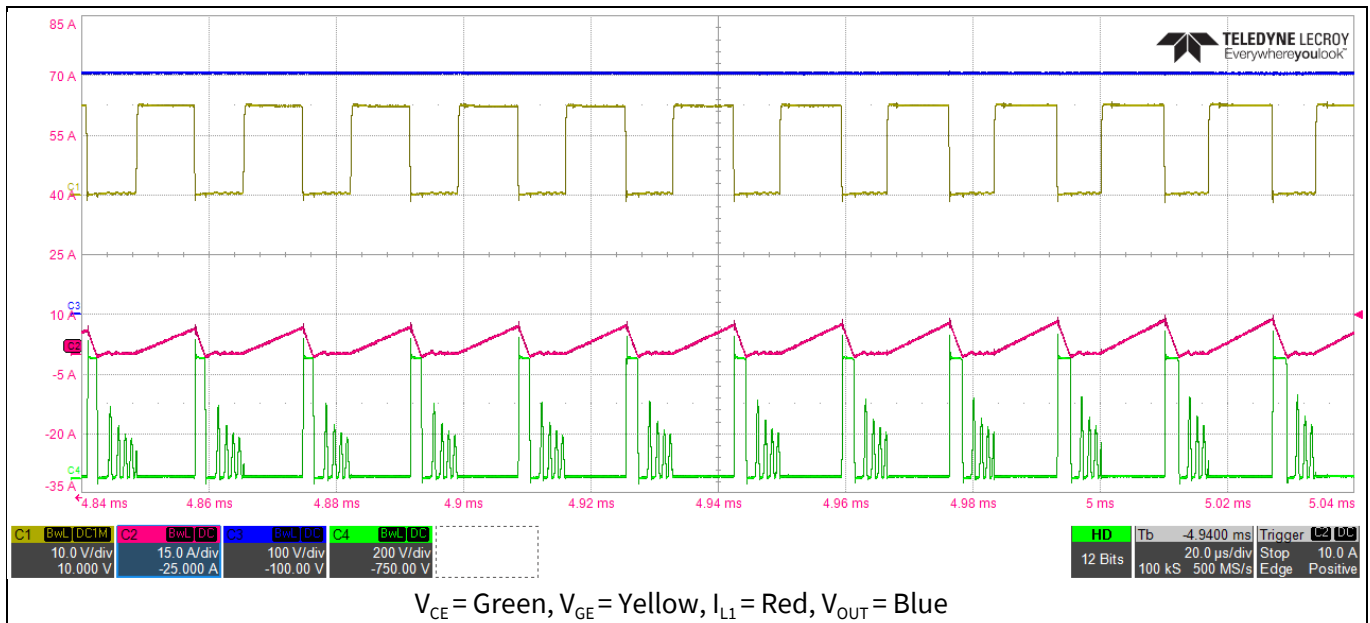

Figure 28 Switching waveforms of the IGBT at $V_{IN} = 200 V_{AC}$ at full load (discontinuous current around the zero crossing of AC input voltage)

4.5 Output ripple voltage

Due to cost considerations and the limitation of board size, only four output filter capacitors with a total value of 2720 μF are placed at the output stage. As can be seen in the following three waveforms, at full load for different input voltages the maximum allowed low-frequency ripple of the output voltage is less than 20 V, which meets the design specifications as well.

5 kW two-channel interleaved CCM PFC EVAL board

IKWH40N65WR6, IDW60C65D1 and 1ED44175 in high frequency PFC application



System performance

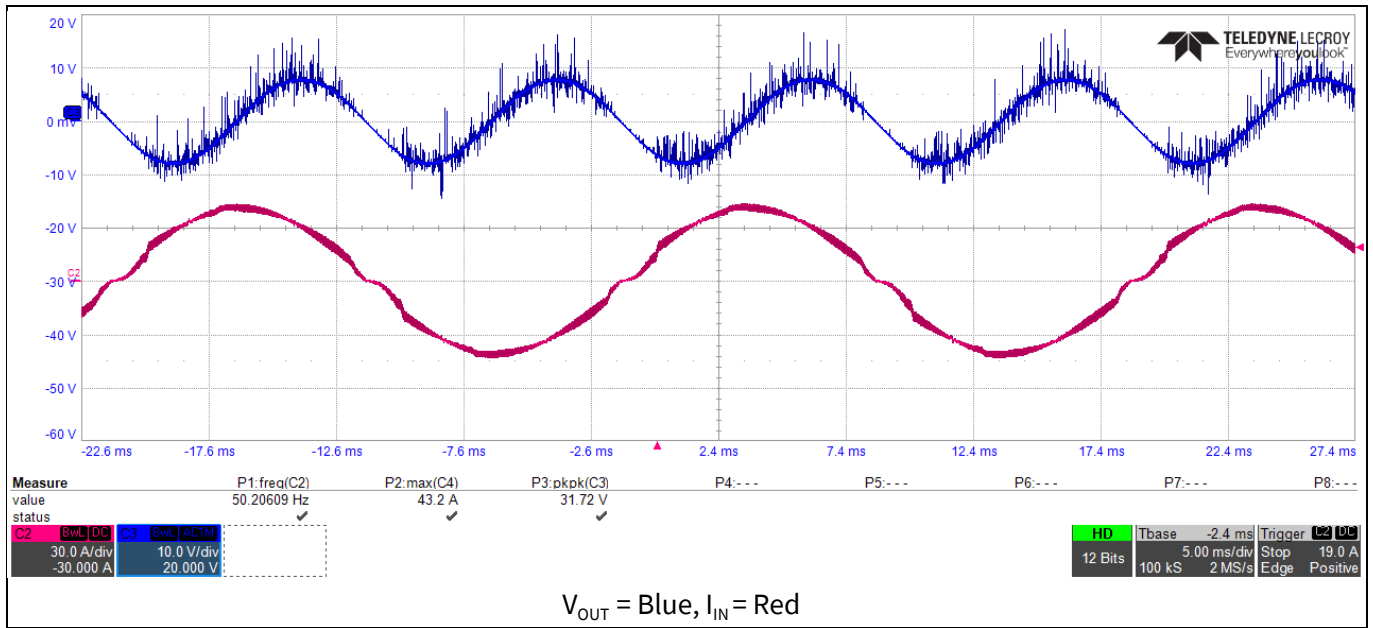

Figure 29 PFC output ripple voltage at $V_{IN} = 180 V_{AC}$ at full load

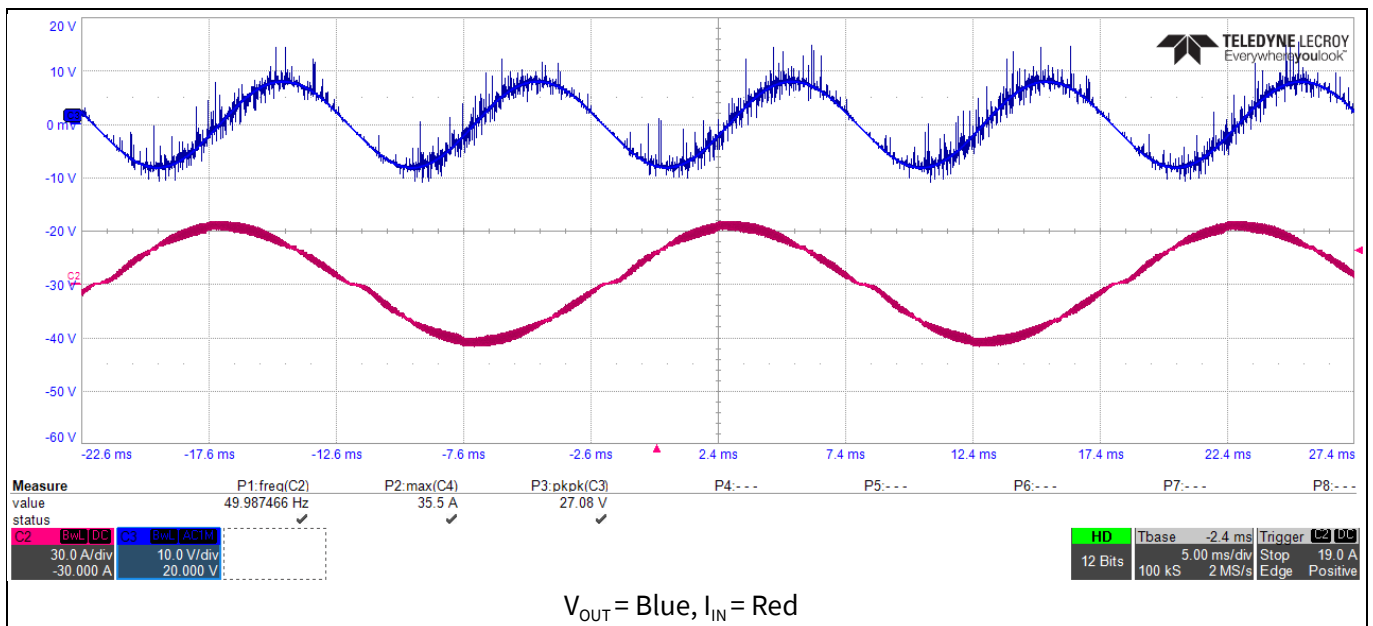

Figure 30 PFC output ripple voltage at $V_{IN} = 230 V_{AC}$ at full load

System performance

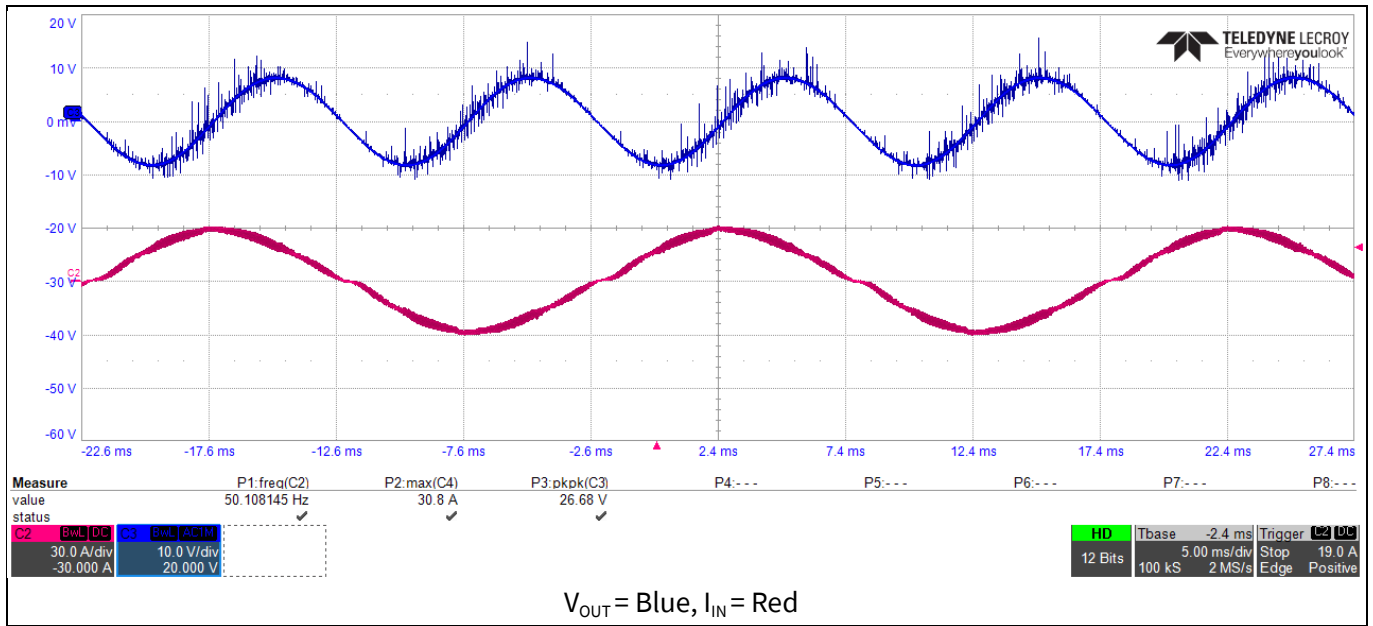

Figure 31 PFC output ripple voltage at $V_{IN} = 264 V_{AC}$ at full load

4.6 Input voltage and input current

The line current shown in the following figures is nearly perfect sinusoidal wave in-phase with the line voltage, while the output voltage is regulated at 400 V at full load.

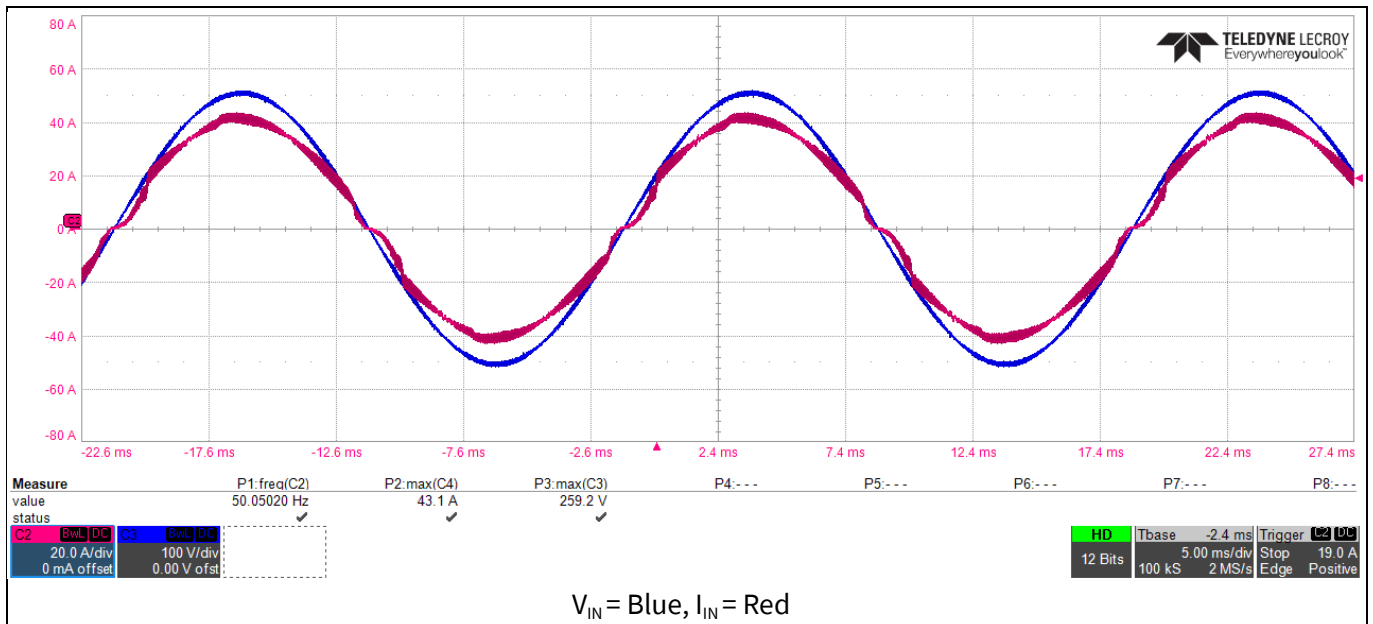

Figure 32 PFC input voltage and input current at $V_{IN} = 180 V_{AC}$ at full load

System performance

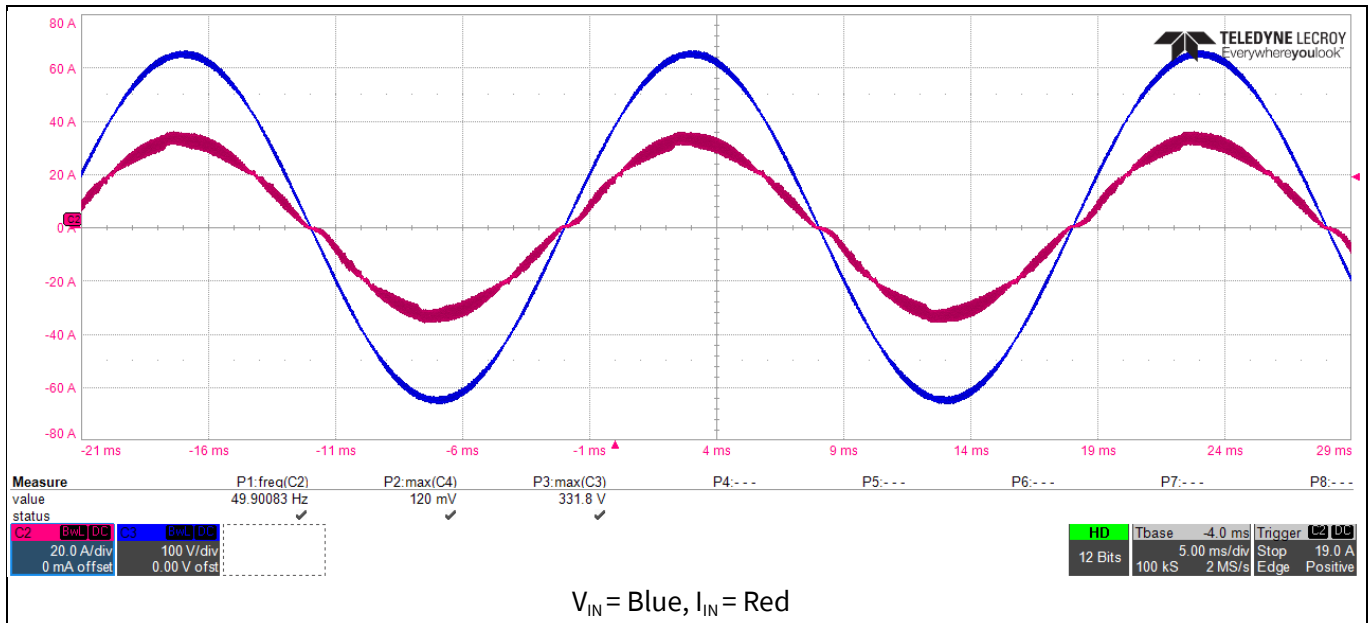

Figure 33 PFC input voltage and input current at $V_{IN} = 230 V_{AC}$ at full load

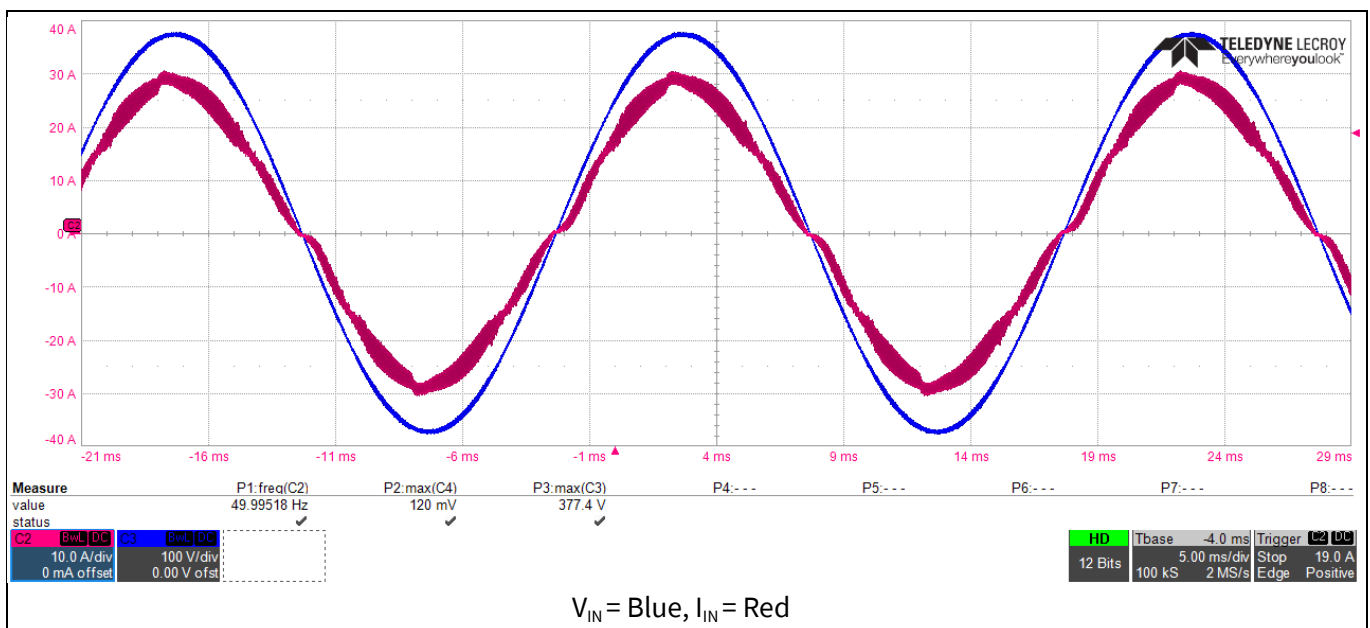

Figure 34 PFC input voltage and input current at $V_{IN} = 264 V_{AC}$ at full load

4.7 Load step tests

Figures 35 and 36 illustrate the response of the PFC converter during a load step from no load to full load with a voltage undershoot down to $352 V_{DC}$ and $360 V_{DC}$, respectively. After such an abrupt load demand, the PFC controller returns to regulation in around 60 milliseconds.

5 kW two-channel interleaved CCM PFC EVAL board

IKWH40N65WR6, IDW60C65D1 and 1ED44175 in high frequency PFC application



System performance

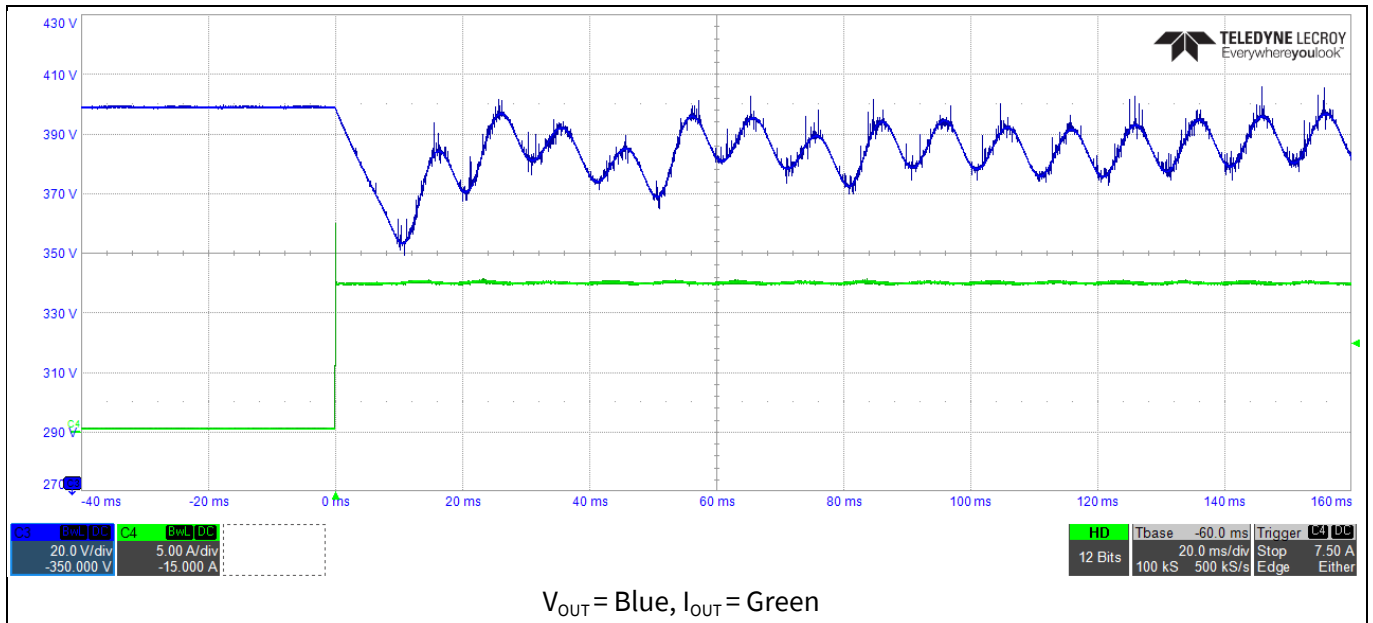

Figure 35 Load step: 0% → 100% at $V_{IN} = 180 V_{AC}$

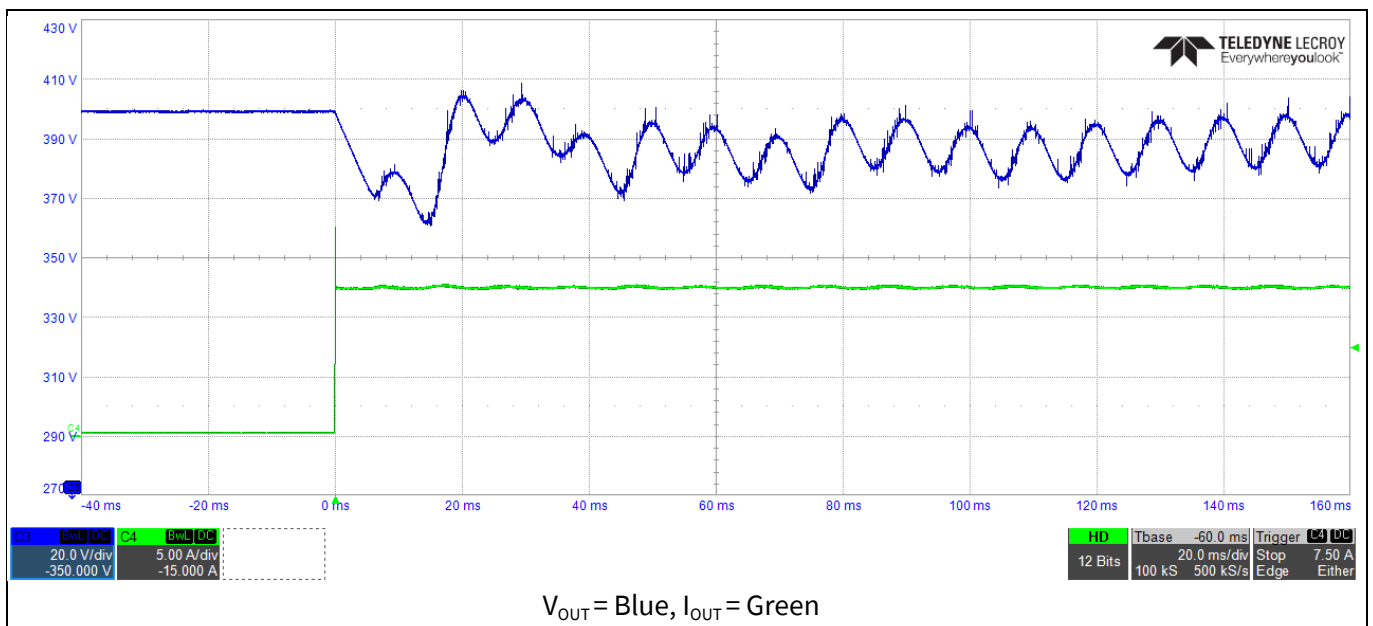

Figure 36 Load step: 0% → 100% at $V_{IN} = 264 V_{AC}$

Figure 37 shows the response of the voltage control loop during a load step from 100% to 0% with a voltage overshoot of up to 425 V. A similar response can be observed at $V_{IN} = 230 V_{AC}$ and $V_{IN} = 264 V_{AC}$.

System performance

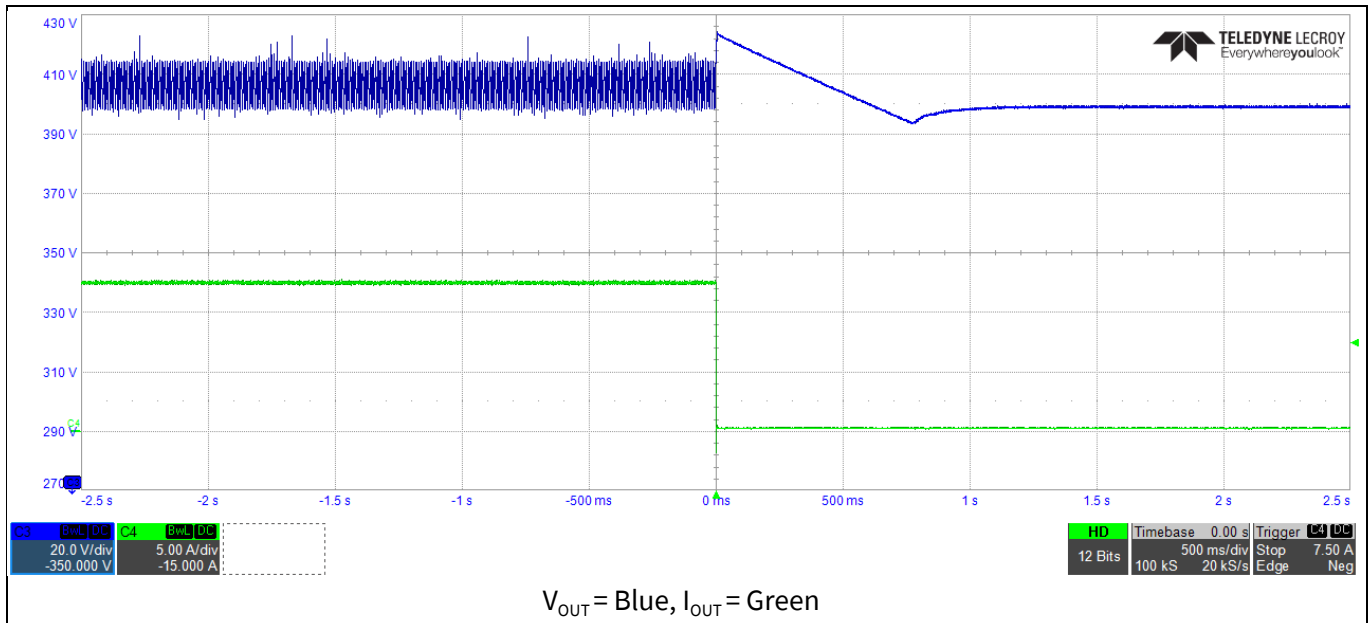

Figure 37 Load step: 100% → 0% at $V_{IN} = 180 V_{AC}$

4.8 Thermal measurements

EVAL-PFC5KIKWWR6SYS is delivered in a closed case. The implemented thermal concept uses two low-power fans attached to two heat sinks in which the power semiconductors dissipate their generated losses.

System performance

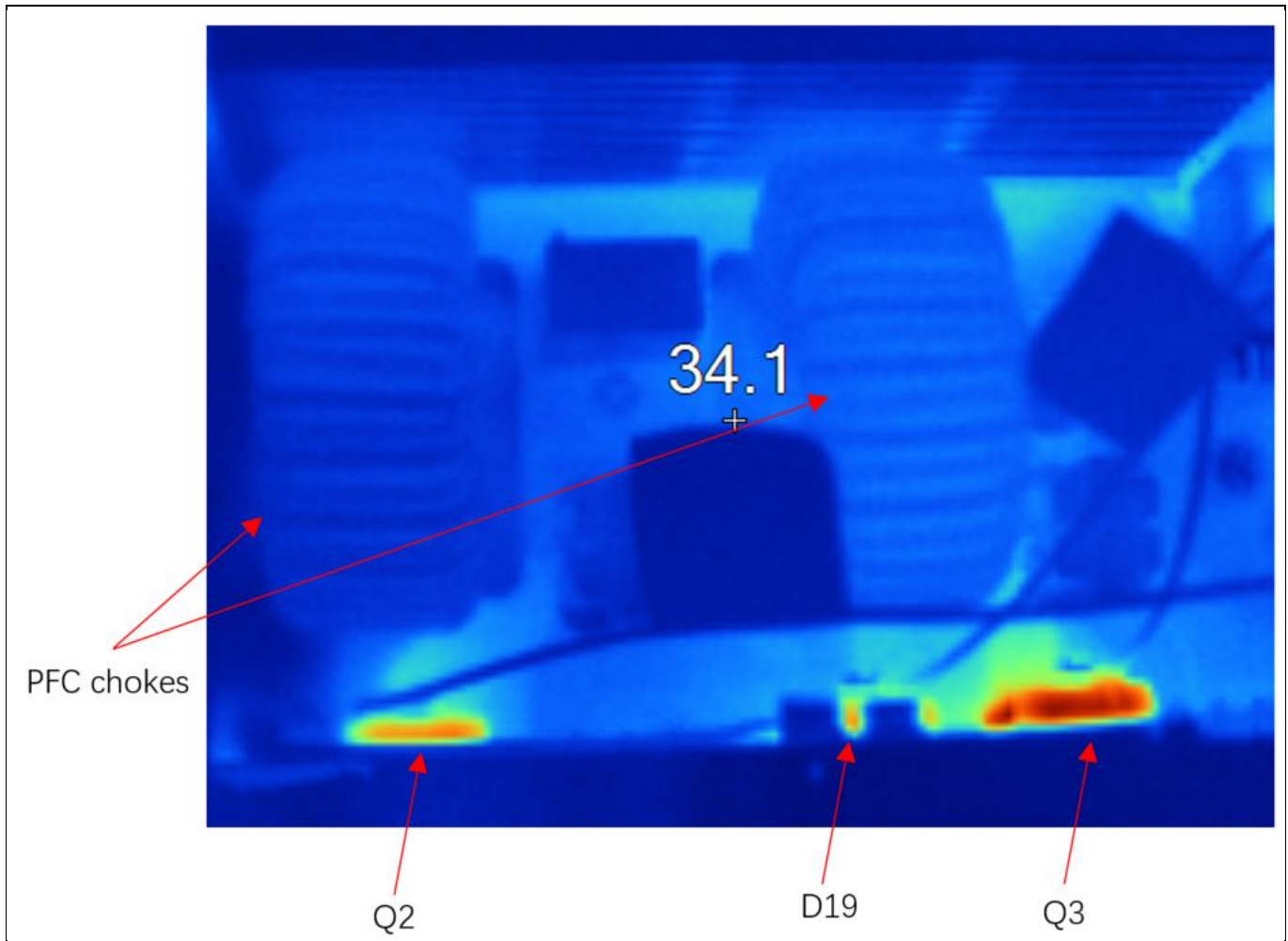

Figure 38 Thermal capture at room temperature at nominal input (180 V) and full load condition for the PFC operation

As seen in Figure 38, the PFC chokes are not the hotspots of the board. This is because of the two powerful fans in an enclosed environment. The WR6 IGBT Q3 that is farther away from the cooling fans is the hottest power device in this board. According to the temperature data measured with Keysight 34970A using thermocouples, the highest temperature of the IGBT is 84.2°C at full load while the input voltage is 180 V_{AC} (see Table 5.) Furthermore, at half load, the IGBT’s highest temperature is only 45.9°C even when the input voltage is 180 V_{AC} (see Table 5.)

Table 5 Temperature of power semiconductors

Devices	V _{IN} = 230 V _{AC} , full load	V _{IN} = 180 V _{AC} , full load	V _{IN} = 180 V _{AC} , half load
Q2 (IKWH40N65WR6)	51.7°C	67.8°C	39.8°C
D19 (IDW60C65D1)	61.6°C	74.2°C	40.3°C
Q3 (IKWH40N65WR6)	62.1°C	84.2°C	45.9°C

Conclusions

5 Conclusions

This user guide describes the implementation of an analog-controlled, single-phase, two-channel interleaved PFC converter that operates in continuous conduction mode. This interleaved PFC converter achieves a peak efficiency of 98.03% by using the Infineon's 650 V TRENCHSTOP™ 5 WR6 IGBT IKWH40N65WR6 and the rapid1 power silicon diode IDW60C65D1.

The EVAL-PFC5KIKWWR6SYS board has been tested using a programmable AC source and electronic load to demonstrate its key performance and behaviors in a PFC operation.

Customers can further increase the switching frequency to decrease the size and cost of the inductors, or extend the converter's input voltage from 85 V_{AC} to 264 V_{AC}. External parameter settings of the resistors and capacitors of the UCC28070 must also be adapted to the new requirements.

6 References and appendices

6.1 Abbreviations and definitions

Table 6 Abbreviations

Abbreviation	Meaning
CE	Conformité Européenne
EMI	Electromagnetic interference
UL	Underwriters Laboratories
BOM	Bill of Material
QR	Quasi-resonant
PF	Power factor
POCO	A Chinese powder core manufacturer
NPH-L	A powder core material from POCO

6.2 References

- [1] Texas Instruments, “UCC28070 300W Interleaved PFC Pre-regulator Design Review (Rev. B)”, Application Report, SLUA479B, August 2008
- [2] Infineon Technologies, “Fifth-generation QR design guide for ICE5QSAG and ICE5QRXXXXAX”, Application Report, DG_201609_PL83_026, September 2017

6.3 Additional information

Click the following links for more information about the Infineon devices mentioned in this guide:

- TRENCHSTOP™ 5 WR6 IGBT [IKWH40N65WR6](#)
- Low-side gate driver [1ED44175N01B](#)
- Rapid1 power silicon diode [IDW60C65D1](#)
- QR Flyback controller [ICE5QSBG](#) for auxiliary supply

Revision history

Revision history

Document version	Date of release	Description of changes
Revision 1.0	June 09, 2022	Initial release

Trademarks

All referenced product or service names and trademarks are the property of their respective owners.

Edition 2022-06-09

Published by

Infineon Technologies AG

81726 Munich, Germany

© 2022 Infineon Technologies AG.

All Rights Reserved.

Do you have a question about this document?

Email: erratum@infineon.com

Document reference

UG-2022-05

For further information on the product, technology, delivery terms and conditions and prices please contact your nearest Infineon Technologies office (www.infineon.com).

WARNINGS

Due to technical requirements products may contain dangerous substances. For information on the types in question please contact your nearest Infineon Technologies office.

Except as otherwise explicitly approved by Infineon Technologies in a written document signed by authorized representatives of Infineon Technologies, Infineon Technologies' products may not be used in any applications where a failure of the product or any consequences of the use thereof can reasonably be expected to result in personal injury.