

Switchmode Lead-Acid Battery Charger

FEATURES

- Accurate and Efficient Control of Battery Charging
- Average Current Mode Control from Trickle to Overcharge
- Resistor Programmable Charge Currents
- Thermistor Interface Tracks Battery Requirements Over Temperature
- Output Status Bits Report on Four Internal Charge States
- Undervoltage Lockout Monitors VCC and VREF

DESCRIPTION

The UC3909 family of Switchmode Lead-Acid Battery Chargers accurately controls lead acid battery charging with a highly efficient average current mode control loop. This chip combines charge state logic with average current PWM control circuitry. Charge state logic commands current or voltage control depending on the charge state. The chip includes undervoltage lockout circuitry to insure sufficient supply voltage is present before output switching starts. Additional circuit blocks include a differential current sense amplifier, a 1.5% voltage reference, a $-3.9\text{mV}/^\circ\text{C}$ thermistor linearization circuit, voltage and current error amplifiers, a PWM oscillator, a PWM comparator, a PWM latch, charge state decode bits, and a 100mA open collector output driver.

BLOCK DIAGRAM

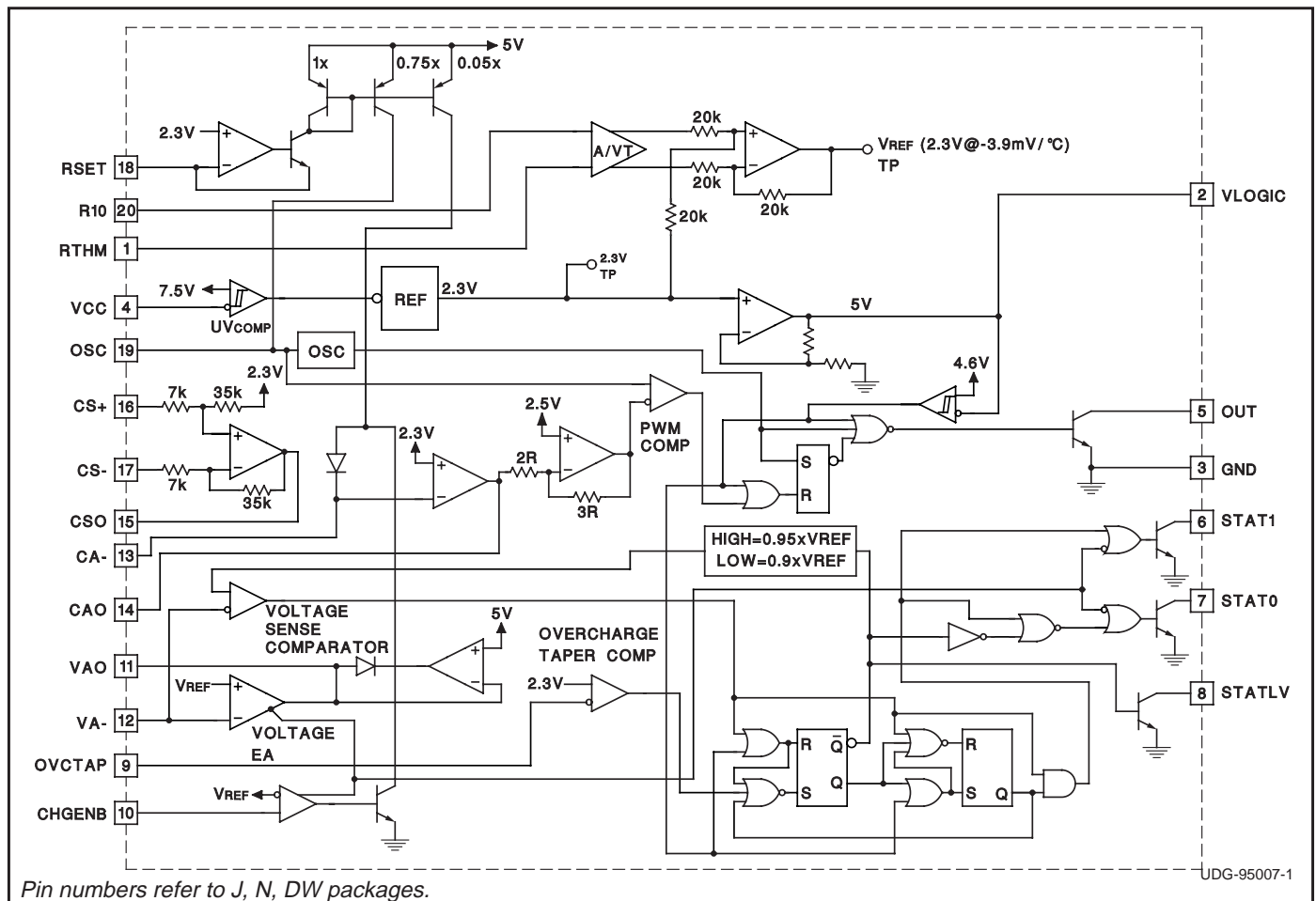

ABSOLUTE MAXIMUM RATINGS

Supply Voltage (VCC), OUT, STAT0, STAT1 40V
 Output Current Sink 0.1A
 CS+, CS- -0.4 to VCC (Note 1)
 Remaining Pin Voltages -0.3V to 9V
 Storage Temperature -65°C to +150°C
 Junction Temperature -55°C to +150°C
 Lead Temperature (Soldering, 10 sec.) +300°C

All currents are positive into, negative out of the specified terminal. Consult Packaging Section of Databook for thermal limitations and considerations of packages.

Note 1: Voltages more negative than -0.4V can be tolerated if current is limited to 50mA.

CONNECTION DIAGRAMS

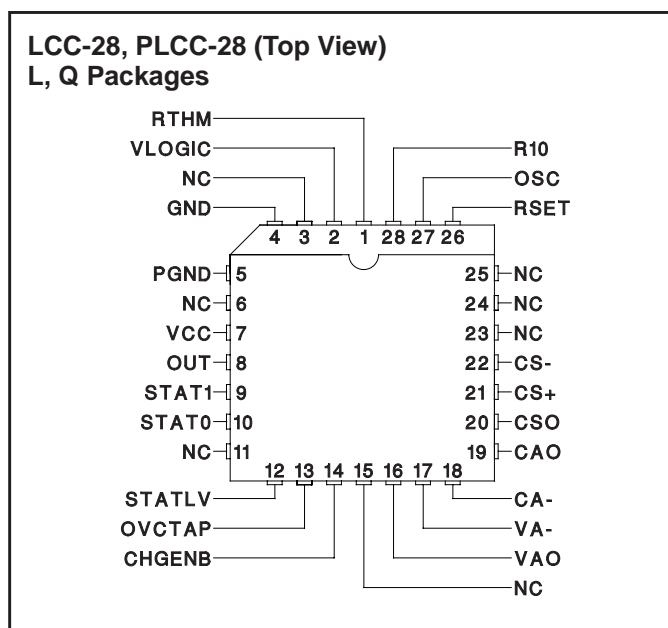
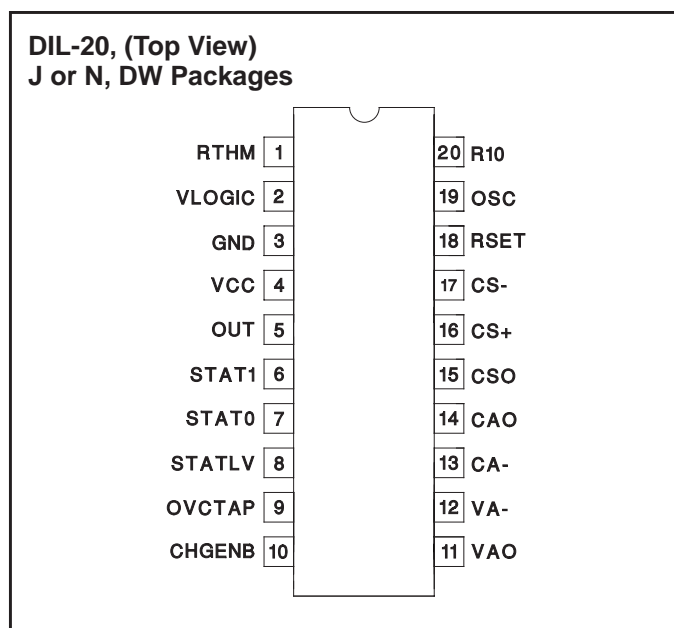

ELECTRICAL CHARACTERISTICS: Unless otherwise stated these specifications apply for $T_A = -40^\circ\text{C}$ to $+85^\circ\text{C}$ for UC2909; 0°C to $+70^\circ\text{C}$ for UC3909; $C_T = 330\text{pF}$, $R_{SET} = 11.5\text{k}$, $R_{10} = 10\text{k}$, $R_{THM} = 10\text{k}$, $V_{CC} = 15\text{V}$, Output no load, $R_{STAT0} = R_{STAT1} = 10\text{k}$, $CHGENB = OVCTAP = VLOGIC$, $T_A = T_J$.

PARAMETER	TEST CONDITIONS	MIN	TYP	MAX	UNITS
Current Sense AMP (CSA) Section					
$V_{ID} = CS+ - CS-$					
DC Gain	$CS- = 0, CS+ = -50\text{mV}; CS+ = -250\text{mV}$	4.90	5	5.10	V/V
	$CS+ = 0, CS- = 50\text{mV}; CS- = 250\text{mV}$	4.90	5	5.10	V/V
$V_{OFFSET} (V_{CSO} - V_{CAO})$	$CS+ = CS- = 2.3\text{V}, CAO = CA-$			15	mV
CMRR	$V_{CM} = -0.25$ to $V_{CC} - 2, 8.8 < V_{CC} < 14$	50			dB
	$V_{CM} = -0.25$ to $V_{CC}, 14 < V_{CC} < 35$	50			dB
V_{OL}	$V_{ID} = -550\text{mV}, -0.25\text{V} < V_{CM} < V_{CC} - 2,$ $I_O = 500\mu\text{A}$		0.3	0.6	V
V_{OH}	$V_{ID} = +700\text{mV}, -0.25\text{V} < V_{CM} < V_{CC} - 2,$ $I_O = -250\mu\text{A}$	5.2	5.7	6.2	V
Output Source Current	$V_{ID} = +700\text{mV}, CSO = 4\text{V}$		-1	-0.5	mA
Output Sink Current	$V_{ID} = -550\text{mV}, CSO = 1\text{V}$	3	4.5		mA
3dB Bandwidth	$V_{ID} = 90\text{mV}, V_{CM} = 0\text{V}$	200			kHz

ELECTRICAL CHARACTERISTICS: Unless otherwise stated these specifications apply for $T_A = -40^{\circ}\text{C}$ to $+85^{\circ}\text{C}$ for UC2909; $^{\circ}\text{C}$ to $+70^{\circ}\text{C}$ for UC3909; $C_T = 330\text{pF}$, $R_{\text{SET}} = 11.5\text{k}$, $R_{10} = 10\text{k}$, $R_{\text{THM}} = 10\text{k}$, $V_{\text{CC}} = 15\text{V}$, Output no load, $R_{\text{STAT}0} = R_{\text{STAT}1} = 10\text{k}$, $\text{CHGENB} = \text{OVCTAP} = \text{VLOGIC}$, $T_A = T_J$.

PARAMETER	TEST CONDITIONS	MIN	TYP	MAX	UNITS
Current Error Amplifier (CEA) Section					
I_B	$8.8\text{V} < V_{\text{CC}} < 35\text{V}$, $V_{\text{CHGENB}} = V_{\text{LOGIC}}$		0.1	0.8	μA
V_{IO} (Note 2)	$8.8\text{V} < V_{\text{CC}} < 35\text{V}$, $\text{CAO} = \text{CA}-$			10	mV
A_{VO}	$1\text{V} < \text{VAO} < 4\text{V}$	60	90		dB
GBW	$T_J = 25^{\circ}\text{C}$, $F = 100\text{kHz}$	1	1.5		MHz
V_{OL}	$I_O = 250\mu\text{A}$		0.4	0.6	V
V_{OH}	$I_O = -5\text{mA}$	4.5	5		V
Output Source Current	$\text{CAO} = 4\text{V}$		-25	-12	mA
Output Sink Current	$\text{CAO} = 1\text{V}$	2	3		mA
$I_{\text{CA}-}$, $I_{\text{TRCK_CONTROL}}$	$V_{\text{CHGENB}} = \text{GND}$	8.5	10	11.5	μA
Voltage Amplifier (CEA) Section					
I_B	Total Bias Current; Regulating Level		0.1	1	μA
V_{IO} (Note 2)	$8.8\text{V} < V_{\text{CC}} < 35\text{V}$, $V_{\text{CM}} = 2.3\text{V}$, $\text{VAO} = \text{VA}-$		1.2		mV
A_{VO}	$1\text{V} < \text{CAO} < 4\text{V}$	60	90		dB
GBW	$T_J = 25^{\circ}\text{C}$, $F = 100\text{kHz}$	0.25	0.5		MHz
V_{OL}	$I_O = 500\mu\text{A}$		0.4	0.6	V
V_{OH}	$I_O = -500\mu\text{A}$	4.75	5	5.25	V
Output Source Current	$\text{CAO} = 4\text{V}$	-2	-1		mA
Output Sink Current	$\text{CAO} = 1\text{V}$	2	2.5		mA
VAO Leakage: High Impedance State	$V_{\text{CHGENB}} = \text{GND}$, $\text{STAT}0 = 0$ & $\text{STAT}1 = 0$, $\text{VAO} = 2.3\text{V}$	-1		1	μA
Pulse Width Modulator Section					
Maximum Duty Cycle	$\text{CAO} = 0.6\text{V}$	90	95	100	%
Modulator Gain	$\text{CAO} = 2.5\text{V}, 3.2\text{V}$	63	71	80	%/V
OSC Peak			3		V
OSC Valley			1		V
Oscillator Section					
Frequency	$8.8\text{V} < V_{\text{CC}} < 35\text{V}$	198	220	242	kHz
Thermistor Derived Reference Section					
	$V_{\text{ID}} = V_{\text{RTHM}} - V_{\text{R}10}$				
Initial Accuracy, VAO (RTHM = 10k)	$V_{\text{ID}} = 0$, $R_{10} = \text{RTHM} = 10\text{k}$ (Note 3)	2.2655	2.3	2.3345	V
	$V_{\text{ID}} = 0$, $R_{10} = \text{RTHM} = 10\text{k}$, $-40^{\circ}\text{C} \leq T_A < 0^{\circ}\text{C}$ (Note 3)	2.254	2.3	2.346	V
Line Regulation	$V_{\text{CC}} = 8.8\text{V}$ to 35V		3	10	mV
VAO	$\text{RTHM} = 138\text{k}$, $R_{10} = 10\text{k}$	2.458	2.495	2.532	V
	$\text{RTHM} = 138\text{k}$, $R_{10} = 10\text{k}$, $-40^{\circ}\text{C} \leq T_A < 0^{\circ}\text{C}$	2.445	2.495	2.545	V
	$\text{RTHM} = 33.63\text{k}$, $R_{10} = 10\text{k}$	2.362	2.398	2.434	V
	$\text{RTHM} = 33.63\text{k}$, $R_{10} = 10\text{k}$, $-40^{\circ}\text{C} \leq T_A < 0^{\circ}\text{C}$	2.350	2.398	2.446	V
	$\text{RTHM} = 1.014\text{k}$, $R_{10} = 10\text{k}$	2.035	2.066	2.097	V
	$\text{RTHM} = 1.014\text{k}$, $R_{10} = 10\text{k}$, $-40^{\circ}\text{C} \leq T_A < 0^{\circ}\text{C}$	2.025	2.066	2.107	V
Charge Enable Comparator Section (CEC)					
Threshold Voltage	As a function of $\text{VA}-$	0.99	1	1.01	V/V
Input Bias Current	$\text{CHGENB} = 2.3\text{V}$	-0.5	-0.1		μA

ELECTRICAL CHARACTERISTICS: Unless otherwise stated these specifications apply for $T_A = -40^{\circ}\text{C}$ to $+85^{\circ}\text{C}$ for UC2909; 0°C to $+70^{\circ}\text{C}$ for UC3909; $C_T = 330\text{pF}$, $R_{SET} = 11.5\text{k}$, $R_{10} = 10\text{k}$, $R_{THM} = 10\text{k}$, $V_{CC} = 15\text{V}$, Output no load, $R_{STAT0} = R_{STAT1} = 10\text{k}$, $CHGENB = OVCTAP = VLOGIC$, $T_A = T_J$.

PARAMETER	TEST CONDITIONS	MIN	TYP	MAX	UNITS
Voltage Sense Comparator Section (VSC)					
Threshold Voltage	STAT0 = 0, STAT1 = 0, Function of V_{REF}	0.945	0.95	0.955	V/V
	STAT0 = 1, STAT1 = 0, Function of V_{REF}	0.895	0.9	0.905	V/V
Over Charge Taper Current Comparator Section (OCTIC)					
Threshold Voltage	Function of 2.3V REF, CA- = CAO	0.99	1	1.01	V/V
Input Bias Current	OVCTAP = 2.3V	-0.5	-0.1		μA
Logic 5V Reference Section (VLOGIC)					
VLOGIC	$V_{CC} = 15\text{V}$	4.875	5.0	5.125	V
Line Regulation	$8.8\text{V} < V_{CC} < 35\text{V}$		3	15	mV
Load Regulation	$0 < I_O < 10\text{mA}$		3	15	mV
Reference Comparator Turn-on Threshold			4.3	4.8	V
Short Circuit Current	$V_{REF} = 0\text{V}$	30	50	80	mA
Output Stage Section					
I_{SINK} Continuous			50		mA
I_{PEAK}			100		mA
V_{OL}	$I_O = 50\text{mA}$		1	1.3	V
Leakage Current	$V_{OUT} = 35\text{V}$			25	μA
STAT0 & STAT1 Open Collector Outputs Section					
Maximum Sink Current	$V_{OUT} = 8.8\text{V}$	6	10		mA
Saturation Voltage	$I_{OUT} = 5\text{mA}$		0.1	0.45	V
Leakage Current	$V_{OUT} = 35\text{V}$			25	μA
STATLV Open Collector Outputs Section					
Maximum Sink Current	$V_{OUT} = 5\text{V}$	2.5	5		mA
Saturation Voltage	$I_{OUT} = 2\text{mA}$		0.1	0.45	V
Leakage current	$V_{OUT} = 5\text{V}$			3	μA
UVLO Section					
Turn-on Threshold		6.8	7.8	8.8	V
Hysteresis		100	300	500	mV
I_{CC} Section					
I_{CC} (run)	(See Fig. 1)		13	19	mA
I_{CC} (off)	$V_{CC} = 6.5\text{V}$		2		mA

Note 2: V_{IO} is measured prior to packaging with internal probe pad.

Note 3: Thermistor initial accuracy is measured and trimmed with respect to V_{AO} ; $V_{AO} = V_{A-}$.

PIN DESCRIPTIONS

CA-: The inverting input to the current error amplifier.

CAO: The output of the current error amplifier which is internally clamped to approximately 4V. It is internally connected to the inverting input of the PWM comparator.

CS-, CS+: The inverting and non-inverting inputs to the current sense amplifier. This amplifier has a fixed gain of five and a common-mode voltage range of from -250mV to $+V_{CC}$.

CSO: The output of the current sense amplifier which is internally clamped to approximately 5.7V.

CHGENB: The input to a comparator that detects when battery voltage is low and places the charger in a trickle charge state. The charge enable comparator makes the output of the voltage error amplifier a high impedance while forcing a fixed $10\mu\text{A}$ into CA- to set the trickle charge current.

PIN DESCRIPTIONS (cont.)

GND: The reference point for the internal reference, all thresholds, and the return for the remainder of the device. The output sink transistor is wired directly to this pin.

OVCTAP: The overcharge current taper pin detects when the output current has tapered to the float threshold in the overcharge state.

OSC: The oscillator ramp pin which has a capacitor (C_T) to ground. The ramp oscillates between approximately 1.0V to 3.0V and the frequency is approximated by:

$$frequency = \frac{1}{1.2 \cdot C_T \cdot R_{SET}}$$

OUT: The output of the PWM driver which consists of an open collector output transistor with 100mA sink capability.

R10: Input used to establish a differential voltage corresponding to the temperature of the thermistor. Connect a 10k resistor to ground from this point.

RSET: A resistor to ground programs the oscillator charge current and the trickle control current for the oscillator ramp.

The oscillator charge current is approximately $\frac{1.75}{R_{SET}}$.

The trickle control current ($I_{TRCK_CONTROL}$) is approximately $\frac{0.115}{R_{SET}}$.

RTHM: A 10k thermistor is connected to ground and is thermally connected to the battery. The resistance will vary exponentially over temperature and its change is used to vary the internal 2.3V reference by $-3.9mV/^\circ C$. The recommended thermistor for this function is part number L1005-5744-103-D1, Keystone Carbon Company, St. Marys, PA.

STAT0: This open collector pin is the first decode bit used to decode the charge states.

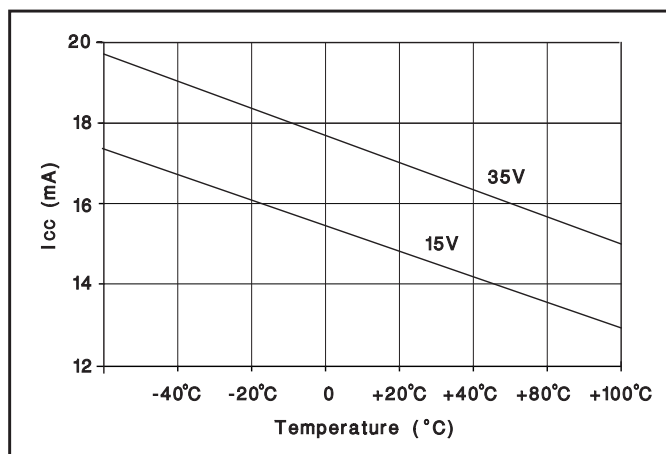

Figure 1. I_{CC} vs. temperature.

STAT1: This open collector pin is the second decode bit used to decode the charge states.

STATLV: This bit is high when the charger is in the float state.

VA- The inverting input to the voltage error amplifier.

VAO: The output of the voltage error amplifier. The upper output clamp voltage of this amplifier is 5V.

VCC: The input voltage to the chip. The chip is operational between 7.5V and 40V and should be bypassed with a $1\mu F$ capacitor. A typical I_{CC} vs. temperature is shown in Figure 1.

VLOGIC: The precision reference voltage. It should be bypassed with a $0.1\mu F$ capacitor.

Charge State Decode Chart

STAT0 and STAT1 are open collector outputs. The output is approximately 0.2V for a logic 0.

	STAT1	STAT0
Trickle Charge	0	0
Bulk Charge	0	1
Over Charge	1	0
Float Charge	1	1

APPLICATION INFORMATION

A Block Diagram of the UC3909 is shown on the first page, while a Typical Application Circuit is shown in Figure 2. The circuit in Figure 2 requires a DC input voltage between 12V and 40V.

The UC3909 uses a voltage control loop with average current limiting to precisely control the charge rate of a lead-acid battery. The small increase in complexity of average current limiting is offset by the relative simplicity of the control loop design.

CONTROL LOOP

Current Sense Amplifier

This amplifier measures the voltage across the sense resistor R_S with a fixed gain of five and an offset voltage of 2.3V. This voltage is proportional to the battery current. The most positive voltage end of R_S is connected to CS—ensuring the correct polarity going into the PWM comparator.

$CSO = 2.3V$ when there is zero battery current.

R_S is chosen by dividing 350mV by the maximum allowable load current. A smaller value for R_S can be chosen to reduce power dissipation.

Maximum Charge Current, I_{bulk} , is set by knowing the maximum voltage error amplifier output, $V_{OH} = 5V$, the maximum allowable drop across R_S , and setting the resistors R_{G1} and R_{G2} such that;

$$\frac{R_{G1}}{R_{G2}} = \frac{5 \cdot V_{RS}}{V_{LOGIC} - CA-} = \frac{5 \cdot V_{RS}}{5V - 2.3V} = \quad (1)$$

$$\frac{5 \cdot V_{RS}}{2.7V} = 1.852 \cdot I_{BULK} \cdot R_S$$

The maximum allowable drop across R_S is specified to limit the maximum swing at CSO to approximately 2.0V to keep the CSO amplifier output from saturating.

No charge/load current: $V_{CSO} = 2.3V$,

Max charge/load current: $V_{max(CSO)} = 2.3V - 2.0V = 0.3V$

Voltage Error Amplifier:

The voltage error amplifier (VEA) senses the battery

voltage and compares it to the 2.3V – 3.9mV/°C thermistor generated reference. Its output becomes the current command signal and is summed with the current sense amplifier output. A 5.0V voltage error amplifier upper clamp limits maximum load current. During the trickle charge state, the voltage amplifier output is opened (high impedance output) by the charge enable comparator. A trickle bias current is summed into the CA— input which sets the maximum trickle charge current.

The VEA, $V_{OH} = 5V$ clamp saturates the voltage loop and consequently limits the charge current as stated in Equation 1.

During the trickle bias state the maximum allowable charge current (ITC) is similarly determined:

$$ITC = \frac{I_{TRICK_CONTROL} \cdot R_{G1}}{R_S \cdot 5} \quad (2)$$

$I_{TRICK_CONTROL}$ is the fixed control current into CA—. $I_{TRICK_CONTROL}$ is 10µA when $R_{SET} = 11.5k$. See RSET pin description for equation.

Current Error Amplifier

The current error amplifier (CA) compares the output of the current sense amplifier to the output of the voltage error amplifier. The output of the CA forces a PWM duty cycle which results in the correct average battery current. With integral compensation, the CA will have a very high DC current gain, resulting in effectively no average DC current error. For stability purposes, the high frequency gain of the CA must be designed such that the magnitude of the down slope of the CA output signal is less than or equal to the magnitude of the up slope of the PWM ramp.

CHARGE ALGORITHM

Refer to Figure 3 in UC3906 Data Sheet in the data book.

A) Trickle Charge State

STAT0 = STAT1 = STATLV = logic 0

When CHGNB is less than V_{REF} (2.3V – 3.9mV/°C), STATLV is forced low. This decreases the sense voltage divider ratio, forcing the battery to overcharge (VOC).

$$VOC = (V_{REF}) \cdot \frac{(R_{S1} + R_{S2} + R_{S3} || R_{S4})}{(R_{S3} || R_{S4})} \quad (3)$$

During the trickle charge state, the output of the voltage error amplifier is high impedance. The trickle control current is directed into the CA— pin setting the maximum trickle charge current. The trickle charge current is defined in Equation 2.

B) Bulk Charge State

STAT1 = STATLV = logic 0, STAT0 = logic 1

As the battery charges, the UC3909 will transition from trickle to bulk charge when CHGENB becomes greater than 2.3V. The transition equation is

$$VT = V_{REF} \cdot \frac{(R_{S1} + R_{S2} + R_{S3} || R_{S4})}{(R_{S2} + R_{S3} || R_{S4})} \quad (4)$$

STATLV is still driven low.

APPLICATION INFORMATION (cont.)

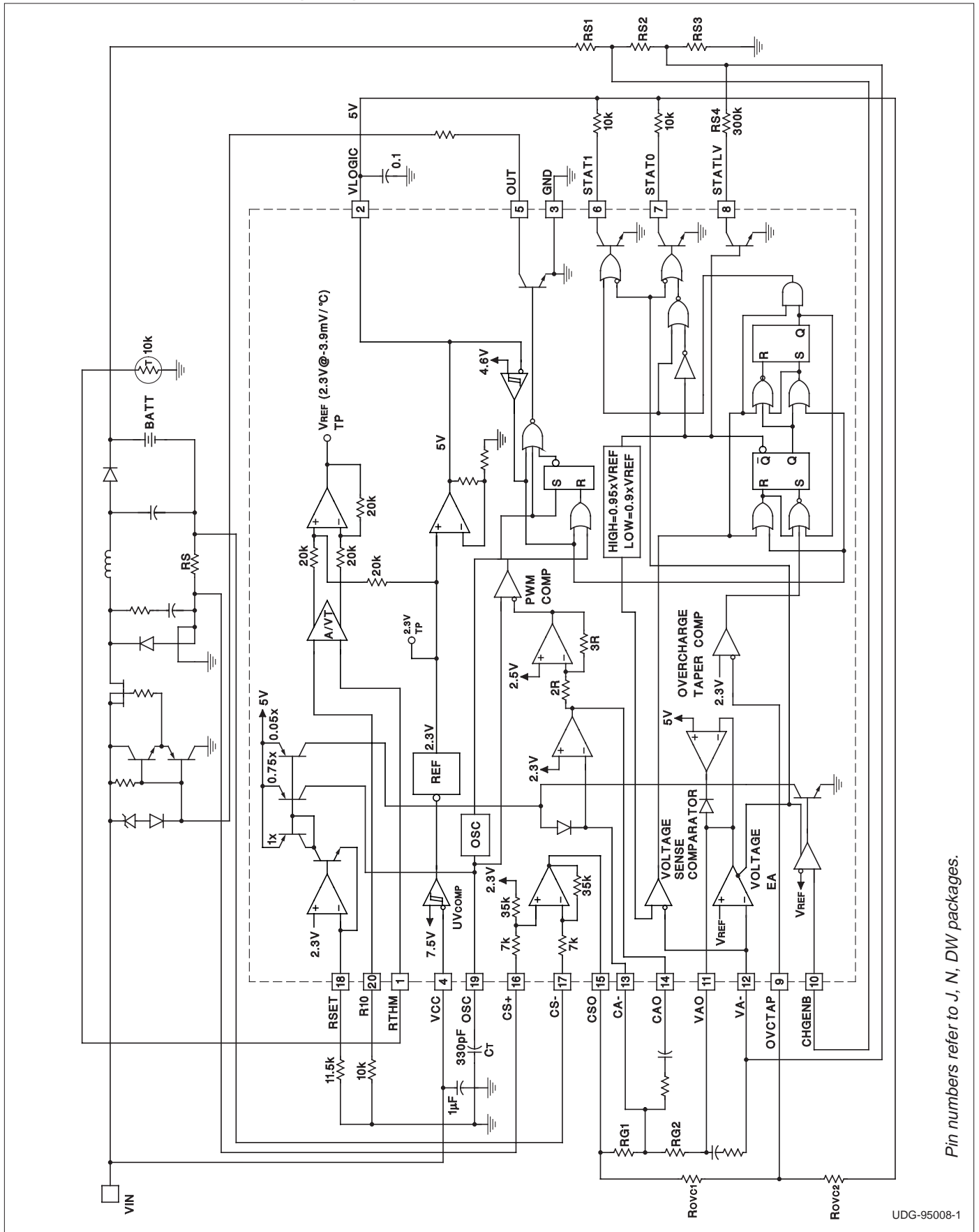

Pin numbers refer to J, N, DW packages.

Figure 2. Typical application circuit

APPLICATION INFORMATION (cont.)

During the bulk charge state, the voltage error amplifier is now operational and is commanding maximum charge current (I_{BULK}) set by Equation 1. The voltage loop attempts to force the battery to VOC.

C) Overcharge State

STAT0 = STATLV = logic 0, STAT1 = logic 1

The battery voltage surpasses 95% of VOC indicating the UC3909 is in its overcharge state.

During the overcharge charge state, the voltage loop becomes stable and the charge current begins to taper off. As the charge current tapers off, the voltage at CSO increases toward its null point of 2.3V. The center connection of the two resistors between CSO and VLOGIC sets the overcurrent taper threshold (OVCTAP). Knowing the desired overcharge terminate current (I_{OCT}), the resistors R_{OVC1} and R_{OVC2} can be calculated by choosing a value of R_{OVC2} and using the following equation:

$$R_{OVC1} = (18518) \cdot I_{OCT} \cdot RS \cdot R_{OVC2} \tag{5}$$

D) Float State

STAT0 = STAT1 = STATLV = logic 1

The battery charge current tapers below its OVCTAP threshold, and forces STATLV high increasing the voltage sense divider ratio. The voltage loop now forces the battery charger to regulate at its float state voltage (V_F).

$$V_F = (V_{REF}) \frac{(RS1+RS2+RS3)}{RS3} \tag{6}$$

If the load drains the battery to less than 90% of V_F , the charger goes back to the bulk charge state, STATE 1.

OFF LINE APPLICATIONS

For off line charge applications, either Figure 3 or Figure 4 can be used as a baseline. Figure 3 has the advantage of high frequency operation resulting in a small isolation transformer. Figure 4 is a simpler design, but at the expense of larger magnetics.

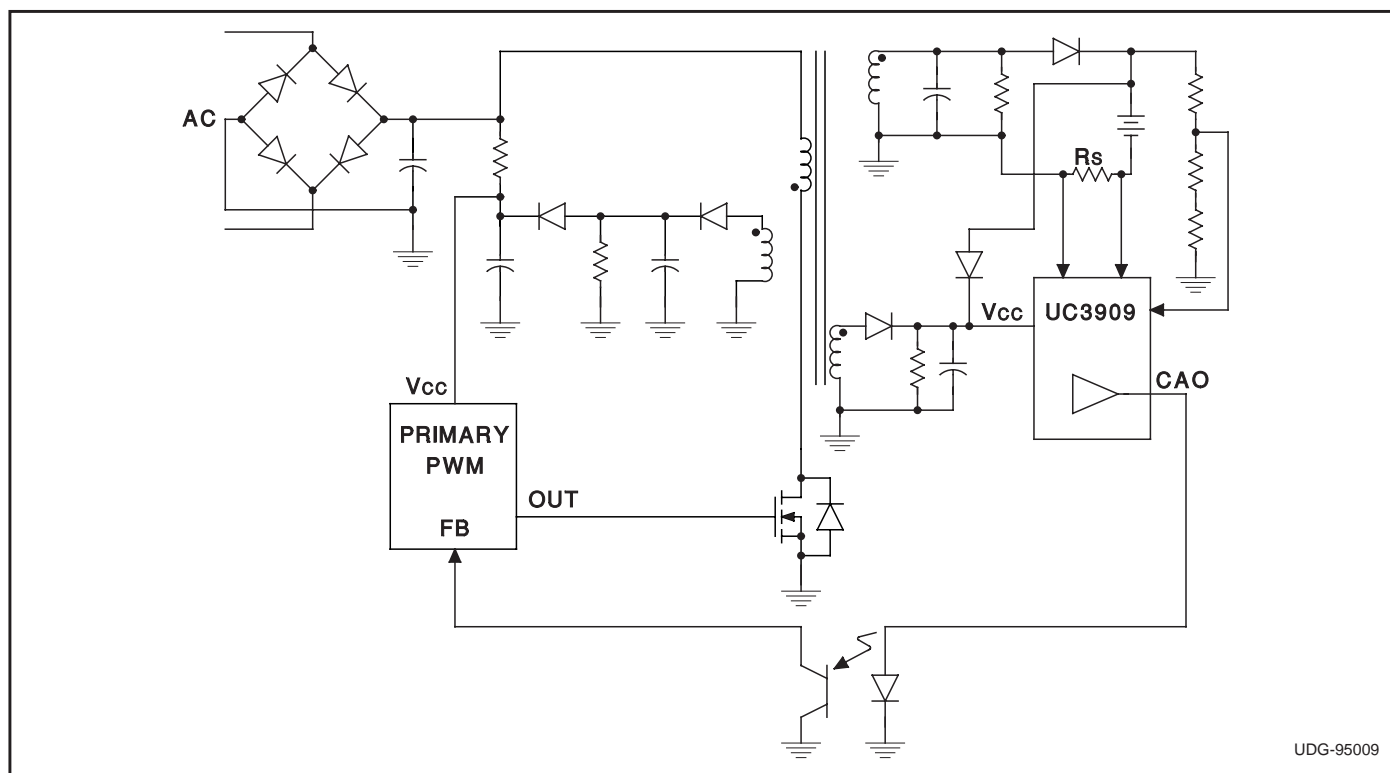

Figure 3. Off line charger with primary side PWM

APPLICATION INFORMATION (cont.)

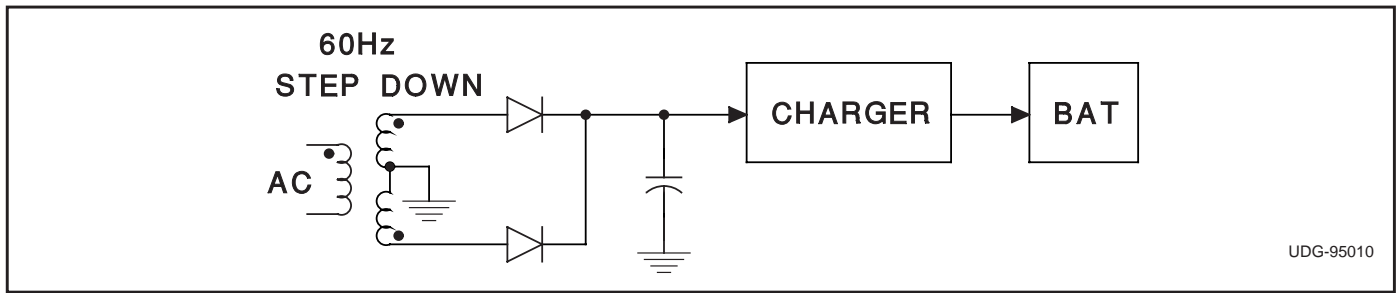

Figure 4. Isolated off line charger

PACKAGING INFORMATION

Orderable Device	Status (1)	Package Type	Package Drawing	Pins	Package Qty	Eco Plan (2)	Lead/Ball Finish	MSL Peak Temp (3)	Op Temp (°C)	Top-Side Markings (4)	Samples
UC2909DW	ACTIVE	SOIC	DW	20	25	Green (RoHS & no Sb/Br)	CU NIPDAU	Level-2-260C-1 YEAR	-40 to 85	UC2909DW	Samples
UC2909DWG4	ACTIVE	SOIC	DW	20	25	Green (RoHS & no Sb/Br)	CU NIPDAU	Level-2-260C-1 YEAR	-40 to 85	UC2909DW	Samples
UC2909DWTR	OBSOLETE	SOIC	DW	20		TBD	Call TI	Call TI	-40 to 85	UC2909DW	
UC2909DWTRG4	OBSOLETE	SOIC	DW	20		TBD	Call TI	Call TI	-40 to 85		
UC2909N	ACTIVE	PDIP	N	20	20	Green (RoHS & no Sb/Br)	CU NIPDAU	N / A for Pkg Type	-40 to 85	UC2909N	Samples
UC2909NG4	ACTIVE	PDIP	N	20	20	Green (RoHS & no Sb/Br)	CU NIPDAU	N / A for Pkg Type	-40 to 85	UC2909N	Samples
UC3909DW	ACTIVE	SOIC	DW	20	25	Green (RoHS & no Sb/Br)	CU NIPDAU	Level-2-260C-1 YEAR	-20 to 70	UC3909DW	Samples
UC3909DWG4	ACTIVE	SOIC	DW	20	25	Green (RoHS & no Sb/Br)	CU NIPDAU	Level-2-260C-1 YEAR	-20 to 70	UC3909DW	Samples
UC3909DWTR	ACTIVE	SOIC	DW	20	2000	Green (RoHS & no Sb/Br)	CU NIPDAU	Level-2-260C-1 YEAR	-20 to 70	UC3909DW	Samples
UC3909DWTRG4	ACTIVE	SOIC	DW	20	2000	Green (RoHS & no Sb/Br)	CU NIPDAU	Level-2-260C-1 YEAR	-20 to 70	UC3909DW	Samples
UC3909N	ACTIVE	PDIP	N	20	20	Green (RoHS & no Sb/Br)	CU NIPDAU	N / A for Pkg Type	-20 to 70	UC3909N	Samples
UC3909NG4	ACTIVE	PDIP	N	20	20	Green (RoHS & no Sb/Br)	CU NIPDAU	N / A for Pkg Type	-20 to 70	UC3909N	Samples

(1) The marketing status values are defined as follows:

ACTIVE: Product device recommended for new designs.

LIFEBUY: TI has announced that the device will be discontinued, and a lifetime-buy period is in effect.

NRND: Not recommended for new designs. Device is in production to support existing customers, but TI does not recommend using this part in a new design.

PREVIEW: Device has been announced but is not in production. Samples may or may not be available.

OBSOLETE: TI has discontinued the production of the device.

(2) Eco Plan - The planned eco-friendly classification: Pb-Free (RoHS), Pb-Free (RoHS Exempt), or Green (RoHS & no Sb/Br) - please check <http://www.ti.com/productcontent> for the latest availability information and additional product content details.

TBD: The Pb-Free/Green conversion plan has not been defined.

Pb-Free (RoHS): TI's terms "Lead-Free" or "Pb-Free" mean semiconductor products that are compatible with the current RoHS requirements for all 6 substances, including the requirement that lead not exceed 0.1% by weight in homogeneous materials. Where designed to be soldered at high temperatures, TI Pb-Free products are suitable for use in specified lead-free processes.

Pb-Free (RoHS Exempt): This component has a RoHS exemption for either 1) lead-based flip-chip solder bumps used between the die and package, or 2) lead-based die adhesive used between the die and leadframe. The component is otherwise considered Pb-Free (RoHS compatible) as defined above.

Green (RoHS & no Sb/Br): TI defines "Green" to mean Pb-Free (RoHS compatible), and free of Bromine (Br) and Antimony (Sb) based flame retardants (Br or Sb do not exceed 0.1% by weight in homogeneous material)

⁽³⁾ MSL, Peak Temp. -- The Moisture Sensitivity Level rating according to the JEDEC industry standard classifications, and peak solder temperature.

⁽⁴⁾ Only one of markings shown within the brackets will appear on the physical device.

Important Information and Disclaimer: The information provided on this page represents TI's knowledge and belief as of the date that it is provided. TI bases its knowledge and belief on information provided by third parties, and makes no representation or warranty as to the accuracy of such information. Efforts are underway to better integrate information from third parties. TI has taken and continues to take reasonable steps to provide representative and accurate information but may not have conducted destructive testing or chemical analysis on incoming materials and chemicals. TI and TI suppliers consider certain information to be proprietary, and thus CAS numbers and other limited information may not be available for release.

In no event shall TI's liability arising out of such information exceed the total purchase price of the TI part(s) at issue in this document sold by TI to Customer on an annual basis.

OTHER QUALIFIED VERSIONS OF UC2909 :

- Enhanced Product: [UC2909-EP](#)

NOTE: Qualified Version Definitions:

- Enhanced Product - Supports Defense, Aerospace and Medical Applications

TAPE AND REEL INFORMATION
REEL DIMENSIONS

TAPE DIMENSIONS

A0	Dimension designed to accommodate the component width
B0	Dimension designed to accommodate the component length
K0	Dimension designed to accommodate the component thickness
W	Overall width of the carrier tape
P1	Pitch between successive cavity centers

TAPE AND REEL INFORMATION

*All dimensions are nominal

Device	Package Type	Package Drawing	Pins	SPQ	Reel Diameter (mm)	Reel Width W1 (mm)	A0 (mm)	B0 (mm)	K0 (mm)	P1 (mm)	W (mm)	Pin1 Quadrant
UC3909DWTR	SOIC	DW	20	2000	330.0	24.4	10.8	13.0	2.7	12.0	24.0	Q1

TAPE AND REEL BOX DIMENSIONS

*All dimensions are nominal

Device	Package Type	Package Drawing	Pins	SPQ	Length (mm)	Width (mm)	Height (mm)
UC3909DWTR	SOIC	DW	20	2000	367.0	367.0	45.0

IMPORTANT NOTICE

Texas Instruments Incorporated and its subsidiaries (TI) reserve the right to make corrections, enhancements, improvements and other changes to its semiconductor products and services per JESD46, latest issue, and to discontinue any product or service per JESD48, latest issue. Buyers should obtain the latest relevant information before placing orders and should verify that such information is current and complete. All semiconductor products (also referred to herein as "components") are sold subject to TI's terms and conditions of sale supplied at the time of order acknowledgment.

TI warrants performance of its components to the specifications applicable at the time of sale, in accordance with the warranty in TI's terms and conditions of sale of semiconductor products. Testing and other quality control techniques are used to the extent TI deems necessary to support this warranty. Except where mandated by applicable law, testing of all parameters of each component is not necessarily performed.

TI assumes no liability for applications assistance or the design of Buyers' products. Buyers are responsible for their products and applications using TI components. To minimize the risks associated with Buyers' products and applications, Buyers should provide adequate design and operating safeguards.

TI does not warrant or represent that any license, either express or implied, is granted under any patent right, copyright, mask work right, or other intellectual property right relating to any combination, machine, or process in which TI components or services are used. Information published by TI regarding third-party products or services does not constitute a license to use such products or services or a warranty or endorsement thereof. Use of such information may require a license from a third party under the patents or other intellectual property of the third party, or a license from TI under the patents or other intellectual property of TI.

Reproduction of significant portions of TI information in TI data books or data sheets is permissible only if reproduction is without alteration and is accompanied by all associated warranties, conditions, limitations, and notices. TI is not responsible or liable for such altered documentation. Information of third parties may be subject to additional restrictions.

Resale of TI components or services with statements different from or beyond the parameters stated by TI for that component or service voids all express and any implied warranties for the associated TI component or service and is an unfair and deceptive business practice. TI is not responsible or liable for any such statements.

Buyer acknowledges and agrees that it is solely responsible for compliance with all legal, regulatory and safety-related requirements concerning its products, and any use of TI components in its applications, notwithstanding any applications-related information or support that may be provided by TI. Buyer represents and agrees that it has all the necessary expertise to create and implement safeguards which anticipate dangerous consequences of failures, monitor failures and their consequences, lessen the likelihood of failures that might cause harm and take appropriate remedial actions. Buyer will fully indemnify TI and its representatives against any damages arising out of the use of any TI components in safety-critical applications.

In some cases, TI components may be promoted specifically to facilitate safety-related applications. With such components, TI's goal is to help enable customers to design and create their own end-product solutions that meet applicable functional safety standards and requirements. Nonetheless, such components are subject to these terms.

No TI components are authorized for use in FDA Class III (or similar life-critical medical equipment) unless authorized officers of the parties have executed a special agreement specifically governing such use.

Only those TI components which TI has specifically designated as military grade or "enhanced plastic" are designed and intended for use in military/aerospace applications or environments. Buyer acknowledges and agrees that any military or aerospace use of TI components which have **not** been so designated is solely at the Buyer's risk, and that Buyer is solely responsible for compliance with all legal and regulatory requirements in connection with such use.

TI has specifically designated certain components as meeting ISO/TS16949 requirements, mainly for automotive use. In any case of use of non-designated products, TI will not be responsible for any failure to meet ISO/TS16949.

Products

Audio	www.ti.com/audio
Amplifiers	amplifier.ti.com
Data Converters	dataconverter.ti.com
DLP® Products	www.dlp.com
DSP	dsp.ti.com
Clocks and Timers	www.ti.com/clocks
Interface	interface.ti.com
Logic	logic.ti.com
Power Mgmt	power.ti.com
Microcontrollers	microcontroller.ti.com
RFID	www.ti-rfid.com
OMAP Applications Processors	www.ti.com/omap
Wireless Connectivity	www.ti.com/wirelessconnectivity

Applications

Automotive and Transportation	www.ti.com/automotive
Communications and Telecom	www.ti.com/communications
Computers and Peripherals	www.ti.com/computers
Consumer Electronics	www.ti.com/consumer-apps
Energy and Lighting	www.ti.com/energy
Industrial	www.ti.com/industrial
Medical	www.ti.com/medical
Security	www.ti.com/security
Space, Avionics and Defense	www.ti.com/space-avionics-defense
Video and Imaging	www.ti.com/video

TI E2E Community

e2e.ti.com