

UBA3070

LED backlight driver IC

Rev. 02 — 2 December 2008

Product data sheet

1. General description

The UBA3070 driver IC is the first member of a first generation of power-efficient LED backlight driver ICs.

Highly efficient, flexible and reliable LED drivers can easily be designed using the UBA3070 control IC.

2. Features

- Switch-mode buck controller that drives strings of LEDs up to 600 V power-efficiently
- Controller with power-efficient boundary conduction mode of operation:
 - ◆ No reverse recovery losses in freewheel diode
 - ◆ Zero current switching for turn-on of switch
 - ◆ Zero voltage or valley switching for turn-on of switch
 - ◆ Minimal required inductance value and size
- Direct Pulse Width Modulation (PWM) dimming available
- Fast transient response through cycle-by-cycle current control, thereby:
 - ◆ Preventing over or undershoots in the LED current
 - ◆ Enabling efficient PWM dimming by quickly turning the converter on and off and thereby removing the need for extra dim switches and high-side drivers
- Single loosely controlled input voltage required for all LED strings in RGB backlights
- No binning on LED forward voltage required
- Protections:
 - ◆ Undervoltage lockout
 - ◆ Leading edge blanking
 - ◆ Overcurrent
 - ◆ Overtemperature
- Low cost LED driver solution:
 - ◆ No Schottky diode required because of zero-current switching
 - ◆ No dim switch and high-side driver required for PWM dimming
 - ◆ Smaller inductor possible compared to fixed-frequency continuous conduction mode controllers

3. Applications

- The UBA3070 is typically suited as a high voltage LED backlighting application in LCD televisions and monitors (See [Figure 1](#))

4. Ordering information

Table 1. Ordering information

Type number	Package		Version
	Name	Description	
UBA3070T	SO8	plastic small outline package; 8 leads; body width 3.9 mm	SOT96-1

5. Block diagram

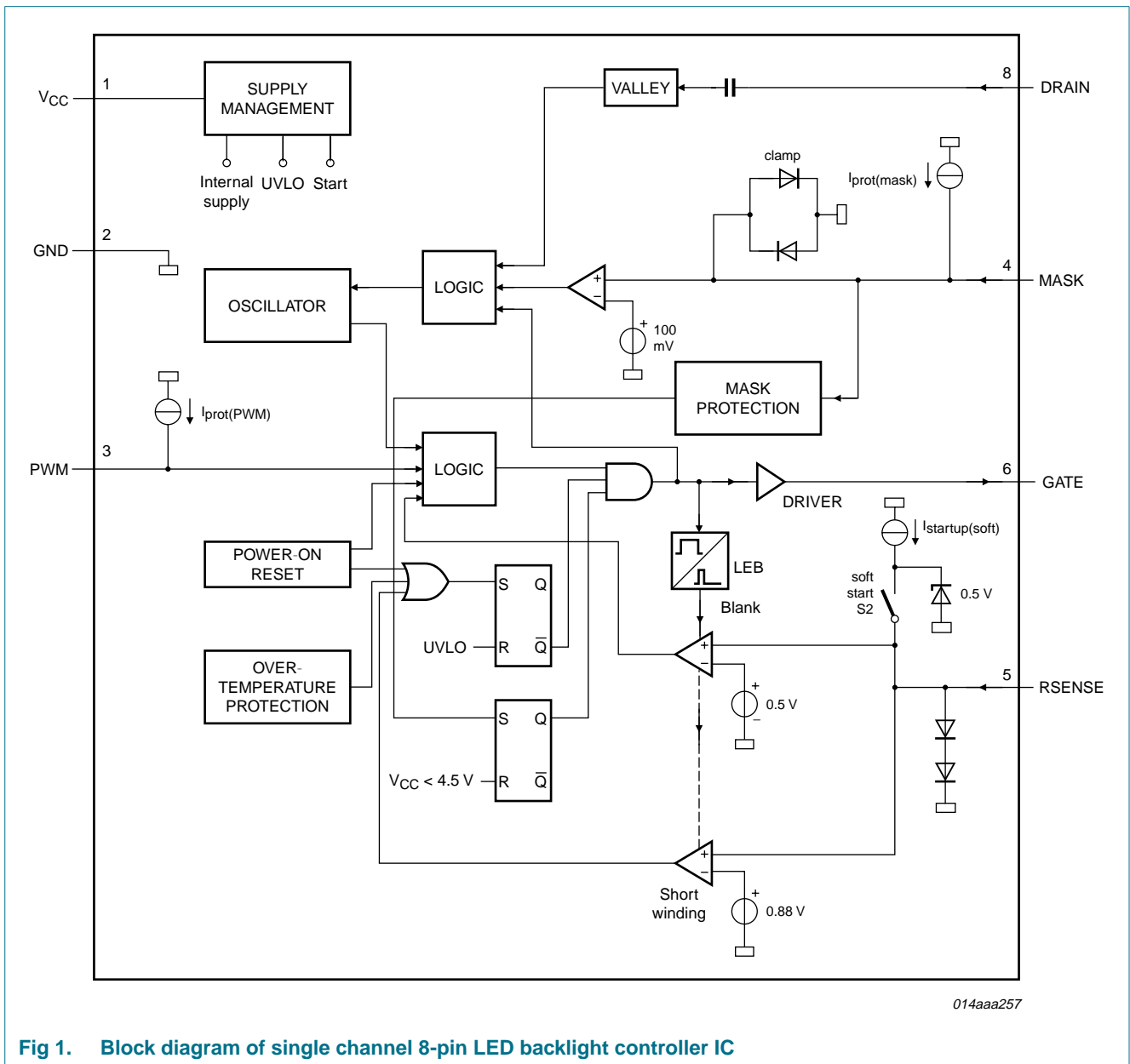

Fig 1. Block diagram of single channel 8-pin LED backlight controller IC

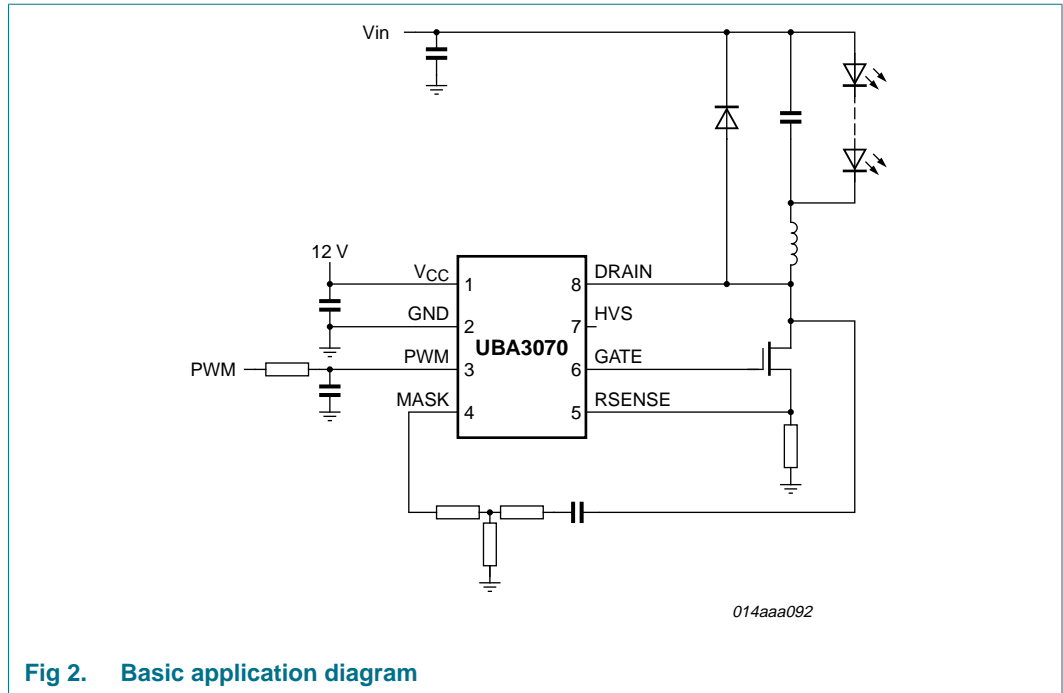

Fig 2. Basic application diagram

6. Pinning information

6.1 Pinning

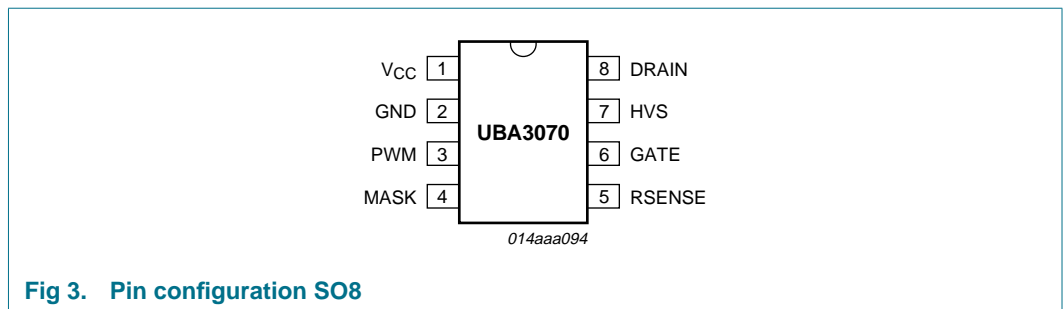

Fig 3. Pin configuration SO8

6.2 Pin description

Table 2. Pin description

Symbol	Pin SO8	Description
V _{CC}	1	supply voltage
GND	2	ground
PWM	3	PWM input voltage
MASK	4	masking input voltage
SENSE	5	resistor programmable current sense input

Table 2. Pin description ...continued

Symbol	Pin SO8	Description
GATE	6	gate driver output
HVS	7	high voltage safety spacer: not connected
DRAIN	8	drain of external MOS switch: input for valley sensing

7. Functional description

The UBA3070 is a monolithic driver IC for controlling the current through LED strings and is especially suitable as driver stage for LED Backlighting applications like LCD televisions.

The driver stage enables optimal performance for series connected LED strings in 0D, 1D and 2D segmented backlight units (BLUs). Since the UBA3070 drives an external power device, it can be used for all kinds of BLU designs ranging from high-power to low-power LEDs, and high-voltage to low-voltage LED strings. Consequently it provides a driver solution for all LCD screen sizes and types of LEDs. By combining the UBA3070 with the appropriate power devices, the amount of drivers can be minimized by optimizing the amount of LEDs put in series.

Each driver stage consists of a buck converter operating in boundary conduction mode of which the peak level can be chosen by means of the external sense resistor. Since the peak and zero levels are fixed by design, the converter behaves as a current source. This gives an average current through the LEDs that is half the peak value of that through the inductor. The ripple current through the LEDs can be chosen by means of the external capacitor in parallel to the LEDs.

7.1 Supply management and undervoltage lockout

As long as V_{CC} is below the $V_{CC(\text{startup})}$ level of typically 10 V, the supply current is below 600 μA . The IC will activate the converter as soon as the voltage on the V_{CC} pin passes the $V_{CC(\text{startup})}$ level. The moment the voltage on pin V_{CC} drops below the undervoltage lockout voltage of typically 8.7 V the IC stops switching.

7.2 Current control and PWM

If the PWM input is high ($> 2\text{ V}$) the converter is disabled, it will not switch and the LED current is zero. If the PWM input pin is low ($< 0.5\text{ V}$) the converter is enabled and operation is as follows. The external FET is turned on and current in the inductor will build up. During this charging phase of the inductor the current is sensed across an external sense resistor. The internal driver turns off the external FET upon detection of a voltage level of typically 0.52 V at the SENSE pin. The inductor will freewheel its current through the external diode and will discharge. After discharge the switch node will ring. Upon detection of a valley or zero voltage on the switch node the internal driver will turn on the external FET. Consequently turn-on of the FET is at zero current and at minimal voltage resulting in minimal power losses and EMI. The conversion cycle will repeat as described above, until the PWM input signal is driven high to disable the converter and steer the LED current to zero.

If the PWM pin is open circuit or not connected, a fault condition is assumed and the converter will stop switching. Operation will recommence as soon as the fault condition is removed.

7.3 Masking and valley switching

The mask pin ensures that turn-on of the converter is at a valley during ringing and not at a peak during freewheeling of the inductor. If the voltage level at the mask pin is typically above 100 mV, then turn-on of the switching FET is prevented. If the voltage level is below this 100 mV, then turn-on prevention of the FET is released and at the moment of valley detection the FET will actually turn on. The signal for the mask pin can be easily derived from the signal at the switch node as shown in the application diagram. The current flowing into the mask pin should be lower than the typical stop current of 60 μ A.

If pin MASK is open circuit or not connected, a fault condition is assumed and the converter will stop operating immediately. Operation will recommence as soon as the fault condition is removed.

7.4 Conversion frequency

The maximum conversion frequency is limited to minimally 145 kHz by an internal oscillator. Consequently the inductance value should be chosen such that with the given supply voltage, LED voltage and component spread the conversion frequency is always smaller than this. There is no limitation for the minimum conversion frequency.

7.5 Minimum on-time

The minimum on-time of the switch mode converter is determined by the leading edge blanking time of typically 370 ns. The leading edge blanking time is required to prevent inadvertent switch off after turn on of the FET due to coupling to the sense node.

7.6 Overcurrent protection

Since the converter behaves as a current source it is principally self-protected from overcurrent. An extra level of protection is added by means of a second trip level at typically 0.88 V at the sense node to protect against short-circuits in external components like diodes, inductors, capacitors or LEDs. Upon detection of this abnormal situation the converter will stop switching.

7.7 Soft start-up (pin SENSE)

To have slow start-up the inductor peak current is slowly increased by the soft start-up function. This can be achieved by inserting a resistor and a capacitor between the SENSE-pin (pin 5) and sense resistor R_{sense} . An internal current source charges the capacitor to $V_{SENSE} = I_{ch} \times R_{ss}$ (about 0.5 V maximum).

The start level and the time constant of the increasing primary current level can be adjusted externally by changing the values of R_{ss} and C_{ss} .

$$I_{DM} = \frac{V_{sense(max)} - (I_{ch} \times R_{ss})}{R_{sense}}$$

$$\tau = R_{ss} \times C_{ss}$$

The charge current I_{ch} will flow as long as the voltage on pin SENSE is below approximately 0.5 V. If the voltage on pin SENSE exceeds 0.5 V, the soft start current source will start limiting current I_{ch} . At $V_{startup}$, the I_{ch} current source is completely switched off, see [Figure 4](#).

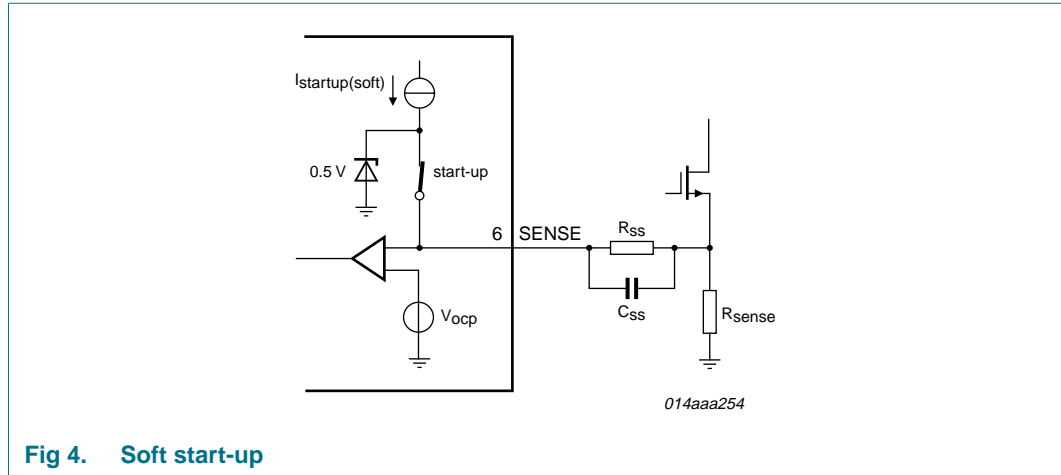

Fig 4. Soft start-up

7.8 Overtemperature protection

An accurate temperature protection is provided in the UBA3070. When the junction temperature exceeds the thermal shutdown temperature of typically 140 °C the converter will stop switching.

7.9 Driver

The driver circuit to the gate of the power FET has a current sourcing capability of 135 mA typical and a current sinking capability of 560 mA typical. This permits fast turn-on and turn-off of the FET for efficient operation. A low driver source current has been chosen to limit the $\Delta V/\Delta t$ at turn-on thereby reducing EMI and voltage spikes across R_{sense} . The driver circuit to the gate of the power MOSFET has a current sourcing capability of 135 mA typical and a current sink capability of 560 mA typical. This permits fast turn-on and turn-off of the power MOSFET for efficient operation.

8. Limiting values

Table 3. Limiting values

In accordance with the Absolute Maximum Rating System (IEC 60134).^[1]

Symbol	Parameter	Conditions	Min	Max	Unit ^[1]
Voltages					
V_{CC}	supply voltage	current limited	-0.4	+20	V
V_{PWM}	voltage on pin PWM		-0.4	+5	V
V_{MASK}	voltage on pin MASK	current limited	-0.4	-	V
V_{SENSE}	voltage on pin SENSE	current limited	-0.4	-	V
V_{DRAIN}	voltage on pin DRAIN		-0.4	+650	V
Currents					
I_{PWM}	current on pin PWM		-	5	mA

Table 3. Limiting values ...continuedIn accordance with the Absolute Maximum Rating System (IEC 60134).^[1]

Symbol	Parameter	Conditions	Min	Max	Unit ^[1]	
I_{MASK}	current on pin MASK		-250	+250	μA	
I_{SENSE}	current on pin SENSE		-1	+10	mA	
I_{GATE}	current on pin GATE	$d < 10\%$	-0.8	+2	A	
I_{DRAIN}	current on pin DRAIN		-	5	mA	
General						
P_{tot}	total power dissipation	$T_{\text{amb}} < 70\text{ }^\circ\text{C}$	-	0.5	W	
T_{stg}	storage temperature		-55	+150	$^\circ\text{C}$	
T_{j}	junction temperature		-40	+145	$^\circ\text{C}$	
ESD						
V_{ESD}	electrostatic discharge voltage					
		all pins except pins DRAIN and V_{CC} ; HBM class 1	^[2]	-	2000	V
		pins DRAIN and V_{CC} ; HBM class 1	^[2]	-	1500	V
		any pin; MM	^[3]	-	200	V

[1] All voltages are measured with respect to ground; positive currents flow into the IC. The pin V_{CC} may not be current driven. The voltage ratings are valid provided other ratings are not violated. The current ratings are valid provided the maximum power rating is not violated.

[2] Human Body Model (HBM): equivalent to discharging a 100 pF capacitor through a 1.5 k Ω resistor.

[3] Machine Model (MM): equivalent to discharging a 200 pF capacitor through a 0.75 μH coil and a 10 Ω resistor.

9. Thermal characteristics

Table 4. Thermal characteristics

Symbol	Parameter	Conditions	Typ	Unit
$R_{\text{th(j-a)}}$	thermal resistance from junction to ambient	In free air	150	K/W

10. Characteristics

Table 5. Characteristics

$T_{\text{amb}} = 25\text{ }^\circ\text{C}$; $V_{\text{CC}} = 15\text{ V}$; all voltages are measured with respect to ground; currents are positive when flowing into the IC; unless otherwise specified.

Symbol	Parameter	Conditions	Min	Typ	Max	Unit
Start-up current source (pin DRAIN)						
V_{BR}	breakdown voltage		650	-	-	V
Supply voltage management (pin V_{CC})						
$V_{\text{CC(startup)}}$	start-up supply voltage		9.3	10	10.6	V
$V_{\text{CC(UVLO)}}$	undervoltage lockout supply voltage		8.1	8.7	9.3	V
$V_{\text{CC(hys)}}$	hysteresis of supply voltage	$V_{\text{CC(startup)}} - V_{\text{CC(UVLO)}}$	1.0	1.3	1.6	V

Table 5. Characteristics ...continued

$T_{amb} = 25^{\circ} C$; $V_{CC} = 15 V$; all voltages are measured with respect to ground; currents are positive when flowing into the IC; unless otherwise specified.

Symbol	Parameter	Conditions	Min	Typ	Max	Unit
$I_{CC(oper)}$	operating supply current	no load on pin GATE	1.1	1.3	1.5	mA
$I_{CC(startup)}$	start-up supply current	$V_{CC} < V_{CC(startup)}$	-	-	600	μA
$I_{CC(prot)}$	protection supply current	$V_{CC} > V_{CC(UVLO)}$	-	0.85	-	mA
Masking management (pin MASK)						
$V_{th(MASK)}$	threshold voltage on pin MASK		50	100	150	mV
$V_{clamp(neg)(MASK)}$	negative clamp voltage on pin MASK	$I_{MASK} = -150 \mu A$	-0.5	-0.25	-0.05	V
$V_{clamp(pos)(MASK)}$	positive clamp voltage on pin MASK	$I_{MASK} = 250 \mu A$	0.5	0.7	0.9	V
$I_{stop(pos)(MASK)}$	positive stop current on pin MASK		54	60	66	μA
$t_{sup(xfmr_ring)}$	transformer ringing suppression time	start secondary shock	1.1	1.5	1.9	μs
$I_{prot(MASK)}$	protection current on pin MASK	$V_{MASK} = 50 mV$	-50 ^[1]	-	-10	nA
Oscillator						
$f_{osc(high)}$	high oscillator frequency	V_{PWM} is low	145	175	205	kHz
PWM duty cycle control (pin PWM)						
$V_{IL(en)ILED(PWM)}$	LED current enable LOW-level input voltage on pin PWM		^[2] -	-	0.5	V
$V_{IH(dis)ILED(PWM)}$	LED current disable HIGH-level input voltage on pin PWM		^[2] 2.0	-	-	V
$I_{prot(PWM)}$	protection current on pin PWM	$V_{PWM} = 1.5 V$	-1.0 ^[1]	-0.8	-0.5	μA
Valley switch (pin DRAIN)						
$(\Delta V/\Delta t)_{vrec}$	valley recognition voltage change with time		-85	-	+85	V/ μs
$t_{d(vrec-swon)}$	valley recognition to switch-on delay time		-	150 ^[1]	-	ns
Overcurrent protection (pin SENSE)						
$V_{sense(max)}$	maximum sense voltage	$\Delta V/\Delta t = 0.1 V/\mu s$	0.48	0.52	0.56	V
t_{PD}	propagation delay	$\Delta V/\Delta t = 0.5 V/\mu s$	-	140	185	ns
V_{swp}	short-winding protection voltage		0.83	0.88	0.95	V
t_{leb}	leading edge blanking time		300	370	440	ns
$I_{startup(soft)}$	soft startup current	$R_{sense} < 0.5 V$	45	60	75	μA
Driver (pin GATE)						
I_{source}	source current	$V_{CC} = 9.5 V$; $V_{DRIVER} = 2 V$	-	-135	-	mA
I_{sink}	sink current	$V_{CC} = 9.5 V$; $V_{DRIVER} = 2 V$	-	240	-	mA
		$V_{CC} = 9.5 V$; $V_{DRIVER} = 9.5 V$	-	560	-	mA
$V_{o(max)}$	maximum output voltage	$V_{CC} > 12 V$	-	11.5	12	V

Table 5. Characteristics ...continued

$T_{amb} = 25^{\circ}C$; $V_{CC} = 15V$; all voltages are measured with respect to ground; currents are positive when flowing into the IC; unless otherwise specified.

Symbol	Parameter	Conditions	Min	Typ	Max	Unit
Overtemperature protection						
$T_{pl(max)}$	maximum protection level temperature		130	140	150	$^{\circ}C$
$T_{pl(hys)}$	protection level hysteresis temperature		-	8	-	$^{\circ}C$

[1] Guaranteed by design.

[2] When the voltage at pin PWM is between 0.5 V and 2.0 V the peak current and the frequency will be reduced.

11. Package outline

SO8: plastic small outline package; 8 leads; body width 3.9 mm

SOT96-1

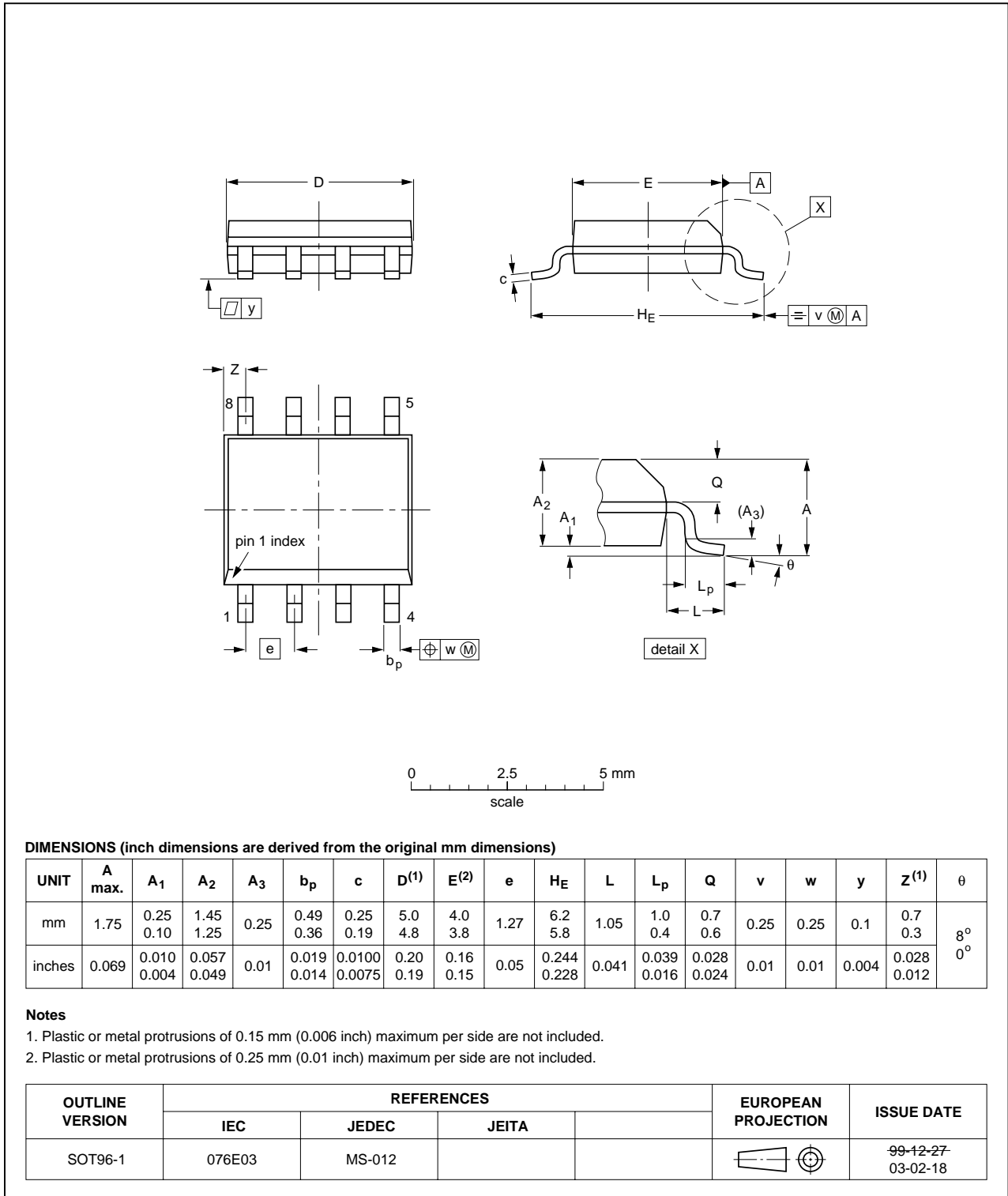

Fig 5. Package outline SOT96-1(SO8)

12. Revision history

Table 6. Revision history

Document ID	Release date	Data sheet status	Change notice	Supersedes
UBA3070_2	20081202	Product data sheet	-	UBA3070_1
Modifications:	• The minimum value for junction temperature has been updated in Table 3 .			
UBA3070_1	20080605	Product data sheet	-	-

13. Legal information

13.1 Data sheet status

Document status ^{[1][2]}	Product status ^[3]	Definition
Objective [short] data sheet	Development	This document contains data from the objective specification for product development.
Preliminary [short] data sheet	Qualification	This document contains data from the preliminary specification.
Product [short] data sheet	Production	This document contains the product specification.

[1] Please consult the most recently issued document before initiating or completing a design.

[2] The term 'short data sheet' is explained in section "Definitions".

[3] The product status of device(s) described in this document may have changed since this document was published and may differ in case of multiple devices. The latest product status information is available on the Internet at URL <http://www.nxp.com>.

13.2 Definitions

Draft — The document is a draft version only. The content is still under internal review and subject to formal approval, which may result in modifications or additions. NXP Semiconductors does not give any representations or warranties as to the accuracy or completeness of information included herein and shall have no liability for the consequences of use of such information.

Short data sheet — A short data sheet is an extract from a full data sheet with the same product type number(s) and title. A short data sheet is intended for quick reference only and should not be relied upon to contain detailed and full information. For detailed and full information see the relevant full data sheet, which is available on request via the local NXP Semiconductors sales office. In case of any inconsistency or conflict with the short data sheet, the full data sheet shall prevail.

13.3 Disclaimers

General — Information in this document is believed to be accurate and reliable. However, NXP Semiconductors does not give any representations or warranties, expressed or implied, as to the accuracy or completeness of such information and shall have no liability for the consequences of use of such information.

Right to make changes — NXP Semiconductors reserves the right to make changes to information published in this document, including without limitation specifications and product descriptions, at any time and without notice. This document supersedes and replaces all information supplied prior to the publication hereof.

Suitability for use — NXP Semiconductors products are not designed, authorized or warranted to be suitable for use in medical, military, aircraft, space or life support equipment, nor in applications where failure or

malfunction of an NXP Semiconductors product can reasonably be expected to result in personal injury, death or severe property or environmental damage. NXP Semiconductors accepts no liability for inclusion and/or use of NXP Semiconductors products in such equipment or applications and therefore such inclusion and/or use is at the customer's own risk.

Applications — Applications that are described herein for any of these products are for illustrative purposes only. NXP Semiconductors makes no representation or warranty that such applications will be suitable for the specified use without further testing or modification.

Limiting values — Stress above one or more limiting values (as defined in the Absolute Maximum Ratings System of IEC 60134) may cause permanent damage to the device. Limiting values are stress ratings only and operation of the device at these or any other conditions above those given in the Characteristics sections of this document is not implied. Exposure to limiting values for extended periods may affect device reliability.

Terms and conditions of sale — NXP Semiconductors products are sold subject to the general terms and conditions of commercial sale, as published at <http://www.nxp.com/profile/terms>, including those pertaining to warranty, intellectual property rights infringement and limitation of liability, unless explicitly otherwise agreed to in writing by NXP Semiconductors. In case of any inconsistency or conflict between information in this document and such terms and conditions, the latter will prevail.

No offer to sell or license — Nothing in this document may be interpreted or construed as an offer to sell products that is open for acceptance or the grant, conveyance or implication of any license under any copyrights, patents or other industrial or intellectual property rights.

13.4 Trademarks

Notice: All referenced brands, product names, service names and trademarks are the property of their respective owners.

14. Contact information

For more information, please visit: <http://www.nxp.com>

For sales office addresses, please send an email to: salesaddresses@nxp.com

15. Contents

1 General description 1

2 Features 1

3 Applications 1

4 Ordering information 2

5 Block diagram 2

6 Pinning information 3

6.1 Pinning 3

6.2 Pin description 3

7 Functional description 4

7.1 Supply management and undervoltage lockout 4

7.2 Current control and PWM 4

7.3 Masking and valley switching 5

7.4 Conversion frequency 5

7.5 Minimum on-time 5

7.6 Overcurrent protection 5

7.7 Soft start-up (pin SENSE) 5

7.8 Overtemperature protection 6

7.9 Driver 6

8 Limiting values 6

9 Thermal characteristics 7

10 Characteristics 7

11 Package outline 10

12 Revision history 11

13 Legal information 12

13.1 Data sheet status 12

13.2 Definitions 12

13.3 Disclaimers 12

13.4 Trademarks 12

14 Contact information 12

15 Contents 13

Please be aware that important notices concerning this document and the product(s) described herein, have been included in section 'Legal information'.



© NXP B.V. 2008.

All rights reserved.

For more information, please visit: <http://www.nxp.com>
 For sales office addresses, please send an email to: salesaddresses@nxp.com

Date of release: 2 December 2008
 Document identifier: UBA3070_2