

TUSB4020BI-Q1 Two-Port USB 2.0 Hub

1 Features

- Two-Port USB 2.0 Hub
- USB 2.0 Hub Features
 - Multi-Transaction Translator (MTT) Hub: Two Transaction Translators
 - Four Asynchronous Endpoint Buffers per Transaction Translator
- DM/DP Polarity Swap
- Type C Compatible
- Supports Battery Charging
 - CDP Mode (Upstream Port Connected)
 - DCP Mode (Upstream Port Unconnected)
 - DCP Mode Complies With Chinese Telecommunications Industry Standard YD/T 1591-2009
 - D+/D– Divider Mode
- Per Port or Ganged Power Switching and Overcurrent Notification Inputs
- OTP ROM, Serial EEPROM, or I²C/SMBus Slave Interface for Custom Configurations:
 - VID and PID
 - Port Customizations
 - Manufacturer and Product Strings (Not by OTP ROM)
 - Serial Number (Not by OTP ROM)
- Application Feature Selection Using Terminal Selection or EEPROM/ or I²C/SMBus Slave Interface
- Provides 128-Bit Universally Unique Identifier (UUID)
- Supports On-Board and In-System OTP/EEPROM Programming Through the USB 2.0 Upstream Port
- Single Clock Input, 24-MHz Crystal or Oscillator
- No Special Driver Requirements; Works Seamlessly on any Operating System With USB Stack Support
- 48-Pin HTQFP Package (PHP)

2 Applications

- Automotive
- Computer Systems
- Docking Stations
- Monitors
- Set-Top Boxes

3 Description

The TUSB4020BI-Q1 is a two-port USB 2.0 hub. It provides USB high-speed/full-speed connections on the upstream port and provides high-speed, full-speed, or low-speed connections on the two downstream ports. When the upstream port is connected to an electrical environment that supports high-speed and full-speed/low-speed connections, high-speed and full-speed/low-speed USB connectivity is enabled on the downstream ports. When the upstream port is connected to an electrical environment that only supports full-speed/low-speed connections, high-speed connectivity are disabled on the downstream ports.

The TUSB4020BI-Q1 supports per port or ganged power switching and overcurrent protection.

An individually port power controlled hub switches power on or off to each downstream port as requested by the USB host. Also when an individually port power controlled hub senses an over-current event, only power to the affected downstream port will be switched off.

A ganged hub switches on power to all its downstream ports when power is required to be on for any port. The power to the downstream ports is not switched off unless all ports are in a state that allows power to be removed. Also when a ganged hub senses an overcurrent event, power to all downstream ports will be switched off.

Device Information⁽¹⁾

PART NUMBER	PACKAGE	BODY SIZE (NOM)
TUSB4020BI-Q1	HTQFP (48)	7.00 mm x 7.00 mm

(1) For all available packages, see the orderable addendum at the end of the data sheet.

Block Diagram

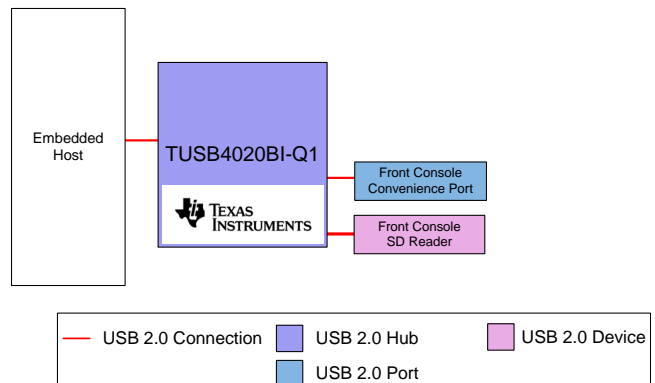

Table of Contents

1 Features	1	8.5 Programming.....	13
2 Applications	1	8.6 Register Maps.....	14
3 Description	1	9 Application and Implementation	26
4 Revision History	2	9.1 Application Information.....	26
5 Description (continued)	3	9.2 Typical Applications	27
6 Pin Configuration and Functions	3	10 Power Supply Recommendations	33
7 Specifications	7	10.1 Power Supply	33
7.1 Absolute Maximum Ratings	7	10.2 Downstream Port Power	33
7.2 ESD Ratings.....	7	10.3 Ground	33
7.3 Recommended Operating Conditions	7	11 Layout	34
7.4 Thermal Information	7	11.1 Layout Guidelines	34
7.5 3.3-V I/O Electrical Characteristics	8	11.2 Layout Example	35
7.6 Hub Input Supply Current	8	12 Device and Documentation Support	37
7.7 Power-Up Timing Requirements	9	12.1 Community Resources.....	37
8 Detailed Description	10	12.2 Trademarks	37
8.1 Overview	10	12.3 Electrostatic Discharge Caution.....	37
8.2 Functional Block Diagram	10	12.4 Glossary	37
8.3 Feature Description.....	11	13 Mechanical, Packaging, and Orderable Information	37
8.4 Device Functional Modes.....	12		

4 Revision History

DATE	REVISION	NOTES
July 2015	*	Initial release.

5 Description (continued)

The TUSB4020BI-Q1 provides terminal strap configuration for some features including battery charging support, and also provides customization through OTP ROM, I²C EEPROM or through an I²C/SMBus slave interface for PID, VID, and custom port and phy configurations. Custom string support is also available when using an I²C EEPROM or the I²C/SMBus slave interface.

The device is available in a 48-pin HTQFP package and is designed for operation over the industrial temperature range of –40°C to 85°C.

6 Pin Configuration and Functions

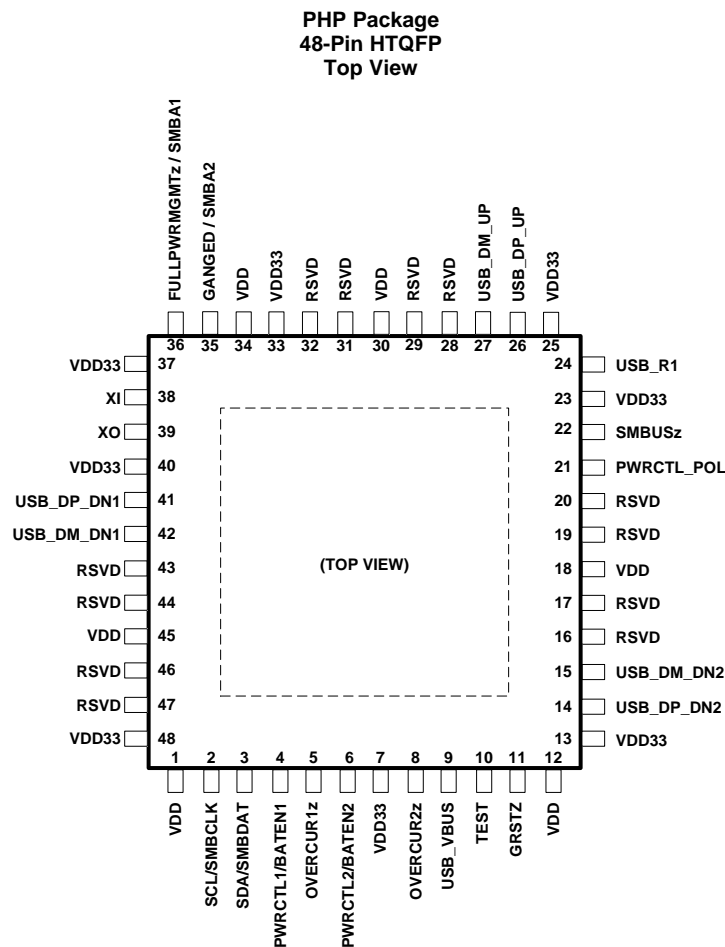

Pin Functions

PIN		TYPE ⁽¹⁾	DESCRIPTION
NAME	NO.		
CLOCK AND RESET SIGNALS			
GRSTz	11	I PU	Global power reset. This reset brings all of the TUSB4020BI-Q1 internal registers to their default states. When GRSTz is asserted, the device is completely nonfunctional.
XI	38	I	Crystal input. This terminal is the crystal input for the internal oscillator. The input may alternately be driven by the output of an external oscillator. When using a crystal a 1-M Ω feedback resistor is required between XI and XO.
XO	39	O	Crystal output. This terminal is the crystal output for the internal oscillator. If XI is driven by an external oscillator this pin may be left unconnected. When using a crystal a 1-M Ω feedback resistor is required between XI and XO.
USB UPSTREAM SIGNALS			
USB_DP_UP	26	I/O	USB high-speed differential transceiver (positive)
USB_DM_UP	27	I/O	USB high-speed differential transceiver (negative)
USB_R1	24	I	Precision resistor reference. A 9.53-k Ω \pm 1% resistor should be connected between USB_R1 and GND.
USB_VBUS	9	I	USB upstream port power monitor. The VBUS detection requires a voltage divider. The signal USB_VBUS must be connected to VBUS through a 90.9-k Ω \pm 1% resistor, and to ground through a 10-k Ω \pm 1% resistor from the signal to ground.
USB DOWNSTREAM SIGNALS			
USB_DP_DN1	41	I/O	USB high-speed differential transceiver (positive) downstream port 1.
USB_DM_DN1	42	I/O	USB high-speed differential transceiver (negative) downstream port 1.
PWRCTL1/BATEN1	4	I/O PD	<p>USB port 1 power-on control for downstream power or battery charging enable. The terminal is used for control of the downstream power switch for Port 1.</p> <p>In addition, the value of the terminal is sampled at the deassertion of reset to determine the value of the battery charging support for Port 1 as indicated in the Battery Charging Support register.</p> <p>0 = Battery charging not supported 1 = Battery charging supported</p>
OVERCUR1z	5	I PU	<p>USB DS port 1 overcurrent detection input. This terminal is used to connect the over current output of the downstream port power switch for port 1.</p> <p>0 = An overcurrent event has occurred 1 = An overcurrent event has not occurred</p> <p>If power management is enabled, the external circuitry needed should be determined by the power switch. In ganged mode, either OVERCUR1z or OVERCUR2z can be used. In ganged mode, the overcurrent will be reported as a hub event instead of a port event.</p>
USB_DP_DN2	14	I/O	USB high-speed differential transceiver (positive) downstream port 2.
USB_DM_DN2	15	I/O	USB high-speed differential transceiver (negative) downstream port 2.
PWRCTL2/BATEN2	6	I/O PD	<p>Power-on control /battery charging enable for downstream port 2. This terminal is used for control of the downstream power switch for port 2.</p> <p>The value of the terminal is sampled at the deassertion of reset to determine the value of the battery charging support for port 2 as indicated in the Battery Charging Support register.</p> <p>0 = Battery charging not supported 1 = Battery charging supported</p>
OVERCUR2z	8	I PU	<p>Overcurrent detection for downstream port 2. This terminal is used to connect the over current output of the downstream port power switch for port 2.</p> <p>0 = An overcurrent event has occurred 1 = An overcurrent event has not occurred</p> <p>If power management is enabled, the external circuitry needed should be determined by the power switch. In ganged mode either OVERCUR1z or OVERCUR2z can be used. In ganged mode the overcurrent will be reported as a hub event instead of a port event.</p>

(1) I = input, O = output, I/O = input/output, PU = internal pullup resistor, PD = internal pulldown resistor, and PWR = power signal

Pin Functions (continued)

PIN		TYPE ⁽¹⁾	DESCRIPTION
NAME	NO.		
I²C/SMBUS SIGNALS			
SCL/SMBCLK	2	I/O PD	<p>I²C clock/SMBus clock. Function of terminal depends on the setting of the SMBUSz input.</p> <p>When SMBUSz = 1, this terminal acts as the serial clock interface for an I²C EEPROM.</p> <p>When SMBUSz = 0, this terminal acts as the serial clock interface for an SMBus host.</p> <p>This pin must be pulled up to use the OTP ROM.</p> <p>Can be left unconnected if external interface not implemented.</p>
SDA/SMBDAT	3	I/O PD	<p>I²C data/SMBus data. Function of terminal depends on the setting of the SMBUSz input.</p> <p>When SMBUSz = 1, this terminal acts as the serial data interface for an I²C EEPROM.</p> <p>When SMBUSz = 0, this terminal acts as the serial data interface for an SMBus host.</p> <p>This pin must be pulled up to use the OTP ROM.</p> <p>Can be left unconnected if external interface not implemented.</p>
TEST AND MISCELLANEOUS SIGNALS			
SMBUSz	22	I PU	<p>SMBUS mode.</p> <p>The value of the terminal is sampled at the deassertion of reset to enable I²C or SMBus mode.</p> <p>0 = SMBus mode selected 1 = I²C mode selected</p> <p>After reset, this signal is driven low by the TUSB4020BI-Q1. Due to this behavior, it is recommended to not tie directly to supply but instead pull-up or pull-down using external resistor.</p>
PWRCTL_POL	21	I/O PD	<p>Power control polarity.</p> <p>The value of the terminal is sampled at the deassertion of reset to set the polarity of PWRCTL[2:1].</p> <p>0 = PWRCTL polarity is active high. 1 = PWRCTL polarity is active low.</p> <p>After reset, this signal is driven low by the TUSB4020BI-Q1. Due to this behavior, it is recommended to not tie directly to supply but instead pull-up or pull-down using external resistor.</p>
GANGED/SMBA2/ HS_UP	35	I PU	<p>Ganged operation enable/SMBus address bit 2/ high-speed status for upstream port</p> <p>The value of the terminal is sampled at the deassertion of reset to set the power switch and over current detection mode as follows:</p> <p>0 = Individual power control supported when power switching is enabled. 1 = Power control gangs supported when power switching is enabled.</p> <p>When SMBus mode is enabled using SMBUSz, this terminal sets the value of the SMBus slave address bit 2. SMBus slave address bits 2 and 3 are always 1 for the TUSB4020BI-Q1.</p> <p>After reset, this signal indicates the high-speed USB connection status of the upstream port. A value of 1 indicates the upstream port is connected to a high-speed USB capable port.</p> <p>Note: Individual power control must be enabled for battery charging applications.</p>

Pin Functions (continued)

PIN		TYPE ⁽¹⁾	DESCRIPTION
NAME	NO.		
FULLPWRMGMTz/ SMBA1	36	I, PU	<p>Full power management enable/ SMBus Address bit 1.</p> <p>The value of the terminal is sampled at the deassertion of reset to set the power switch control follows:</p> <p style="padding-left: 20px;">0 = Power switching supported 1 = Power switching not supported</p> <p>Full power management is the ability to control power to the downstream ports of the TUSB4020BI-Q1 using PWRCTL[2:1]/BATEN[2:1].</p> <p>When SMBus mode is enabled using SMBUSz, this terminal sets the value of the SMBus slave address bit 1. SMBus slave address bit 3 is always 1 for the TUSB4020BI-Q1.</p> <p>Can be left unconnected if full power management and SMBus are not implemented.</p> <p>After reset, this signal is driven low by the TUSB4020BI-Q1. Due to this behavior, it is recommended to not tie directly to supply but instead pull-up or pull-down using external resistor.</p> <p>Note: Power switching must be supported for battery charging applications.</p>
RSVD	16, 17, 19, 20, 28, 29, 31, 32, 43, 44, 46, 47	I/O	Reserved. These pins are for internal use only and should be left unconnected on PCB.
TEST	10	I PD	TEST mode enable. When this terminal is asserted high at reset enables test mode. This terminal is reserved for factory use. It is recommended to pull-down this terminal to ground.
POWER AND GROUND SIGNALS			
VDD	1, 12, 18, 30, 34, 45	PWR	1.1-V power rail
VDD33	7, 13, 23, 25, 33, 37, 40, 48	PWR	3.3-V power rail
GND	PAD	—	Ground

7 Specifications

7.1 Absolute Maximum Ratings⁽¹⁾

over operating free-air temperature (unless otherwise noted)

		MIN	MAX	UNIT
VDD	Steady-state supply voltage	-0.3	1.4	V
VDD33	Steady-state supply voltage	-0.3	3.8	V
T _{stg}	Storage temperature	-65	150	°C

- (1) Stresses beyond those listed under *Absolute Maximum Ratings* may cause permanent damage to the device. These are stress ratings only, which do not imply functional operation of the device at these or any other conditions beyond those indicated under *Recommended Operating Conditions*. Exposure to absolute-maximum-rated conditions for extended periods may affect device reliability.

7.2 ESD Ratings

			VALUE	UNIT	
V _(ESD)	Electrostatic discharge	Human body model (HBM) per AEC Q100-002 ⁽¹⁾	±4000	V	
		Charged device model (CDM) per AEC Q100-011	Corner pins		±1000
			Other pins		±1000

- (1) AEC Q100-002 indicates HBM stressing is done in accordance with ANSI/ESDA/JEDEC JS-001 specification.

7.3 Recommended Operating Conditions

over operating free-air temperature range (unless otherwise noted)

		MIN	NOM	MAX	UNIT
VDD ⁽¹⁾	1.1-V supply voltage	0.99	1.1	1.26	V
VDD33	3.3-V supply voltage	3	3.3	3.6	V
USB_VBUS	Voltage at USB_VBUS pin	0		1.155	V
T _A	Operating free-air temperature range	-40	25	85	°C
T _J	Operating junction temperature range	-40	25	105	°C

- (1) A 1.05-V, 1.1-V, or 1.2-V supply may be used as long as minimum and maximum supply conditions are met.

7.4 Thermal Information

THERMAL METRIC ⁽¹⁾		TUSB4020BI-Q1	UNIT
		PHP (HTQFP)	
		48 PINS	
R _{θJA}	Junction-to-ambient thermal resistance	31.8	°C/W
R _{θJC(top)}	Junction-to-case (top) thermal resistance	16.1	°C/W
R _{θJB}	Junction-to-board thermal resistance	13	°C/W
Ψ _{JT}	Junction-to-top characterization parameter	0.5	°C/W
Ψ _{JB}	Junction-to-board characterization parameter	12.9	°C/W
R _{θJC(bot)}	Junction-to-case (bottom) thermal resistance	0.9	°C/W

- (1) For more information about traditional and new thermal metrics, see the *Semiconductor and IC Package Thermal Metrics* application report, [SPRA953](#).

7.5 3.3-V I/O Electrical Characteristics

over operating free-air temperature range (unless otherwise noted)

PARAMETER		OPERATION	TEST CONDITIONS	MIN	TYP	MAX	UNIT
V _{IH}	High-level input voltage ⁽¹⁾	VDD33		2		VDD33	V
V _{IL}	Low-level input voltage ⁽¹⁾	VDD33		0		0.8	V
V _I	Input voltage			0		VDD33	V
V _O	Output voltage ⁽²⁾			0		VDD33	V
t _t	Input transition time (t _{rise} and t _{fall})			0		25	ns
V _{hys}	Input hysteresis ⁽³⁾					0.13 × VDD33	V
V _{OH}	High-level output voltage	VDD33	I _{OH} = -4 mA	2.4			V
V _{OL}	Low-level output voltage	VDD33	I _{OL} = 4 mA			0.4	V
I _{OZ}	High-impedance, output current ⁽²⁾	VDD33	V _I = 0 to VDD33			±20	μA
I _{OZP}	High-impedance, output current with internal pullup or pulldown resistor ⁽⁴⁾	VDD33	V _I = 0 to VDD33			±225	μA
I _I	Input current ⁽⁵⁾	VDD33	V _I = 0 to VDD33			±15	μA

- (1) Applies to external inputs and bidirectional buffers
 (2) Applies to external outputs and bidirectional buffers
 (3) Applies to GRSTz
 (4) Applies to pins with internal pullups/pulldowns
 (5) Applies to external input buffers

7.6 Hub Input Supply Current

 typical values measured at T_A = 25°C

PARAMETER	VDD33	VDD11	UNIT
	3.3 V	1.1 V	
LOW-POWER MODES			
Power-on (after reset)	5	39	mA
Disconnect from host	5	39	mA
Suspend	5	39	mA
ACTIVE MODES (US STATE / DS STATE)			
2.0 host / 1 HS device active	48	71	mA
2.0 host / 2 HS devices active	60	80	mA

7.7 Power-Up Timing Requirements

		MIN	NOM	MAX	UNIT
t_{d1}	VDD33 stable before VDD stable ⁽¹⁾	see ⁽²⁾			ms
t_{d2}	VDD and VDD33 stable before deassertion of GRSTz	3			ms
t_{su_io}	Setup for MISC inputs ⁽³⁾ sampled at the deassertion of GRSTz	0.1			μ s
t_{hd_io}	Hold for MISC inputs ⁽³⁾ sampled at the deassertion of GRSTz.	0.1			μ s
t_{VDD33_RAMP}	VDD33 supply ramp requirements	0.2		100	ms
t_{VDD_RAMP}	VDD supply ramp requirements	0.2		100	ms

- (1) An active reset is required if the VDD33 supply is stable before the VDD11 supply. This active Reset shall meet the 3ms power-up delay counting from both power supplies being stable to the de-assertion of GRSTz.
- (2) There is no power-on relationship between VDD33 and VDD unless GRSTz is only connected to a capacitor to GND. Then VDD must be stable minimum of 10 μ s before the VDD33.
- (3) MISC pins sampled at deassertion of GRSTz: FULLPWRMGMTz, GANGED, PWRCTL_POL, SMBUSz, BATEN[4:1], and AUTOENZ.

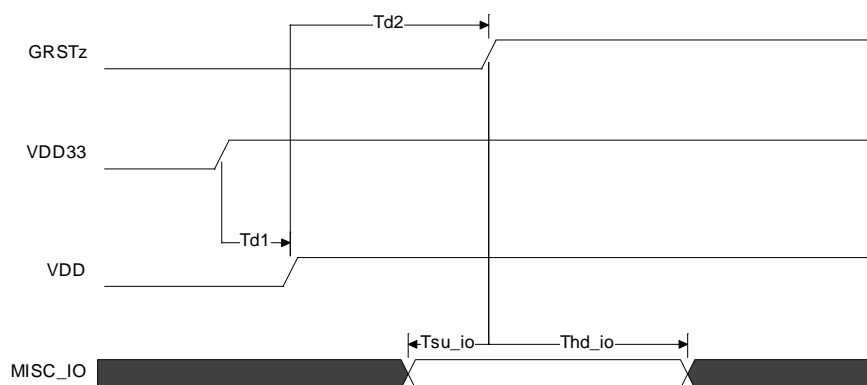

Figure 1. Power-Up Timing Requirements

8 Detailed Description

8.1 Overview

The TUSB4020BI-Q1 is a two-port USB 2.0 hub. It provides USB high-speed/full-speed connections on the upstream port and provides USB high-speed, full-speed, or low-speed connections on the downstream ports. When the upstream port is connected to an electrical environment that supports high-speed and full-speed/low-speed connections, USB high-speed and full-speed/low-speed connectivity is enabled on the downstream ports. When the upstream port is connected to an electrical environment that only supports full-speed/low-speed connections, USB high-speed connectivity are disabled on the downstream ports.

8.2 Functional Block Diagram

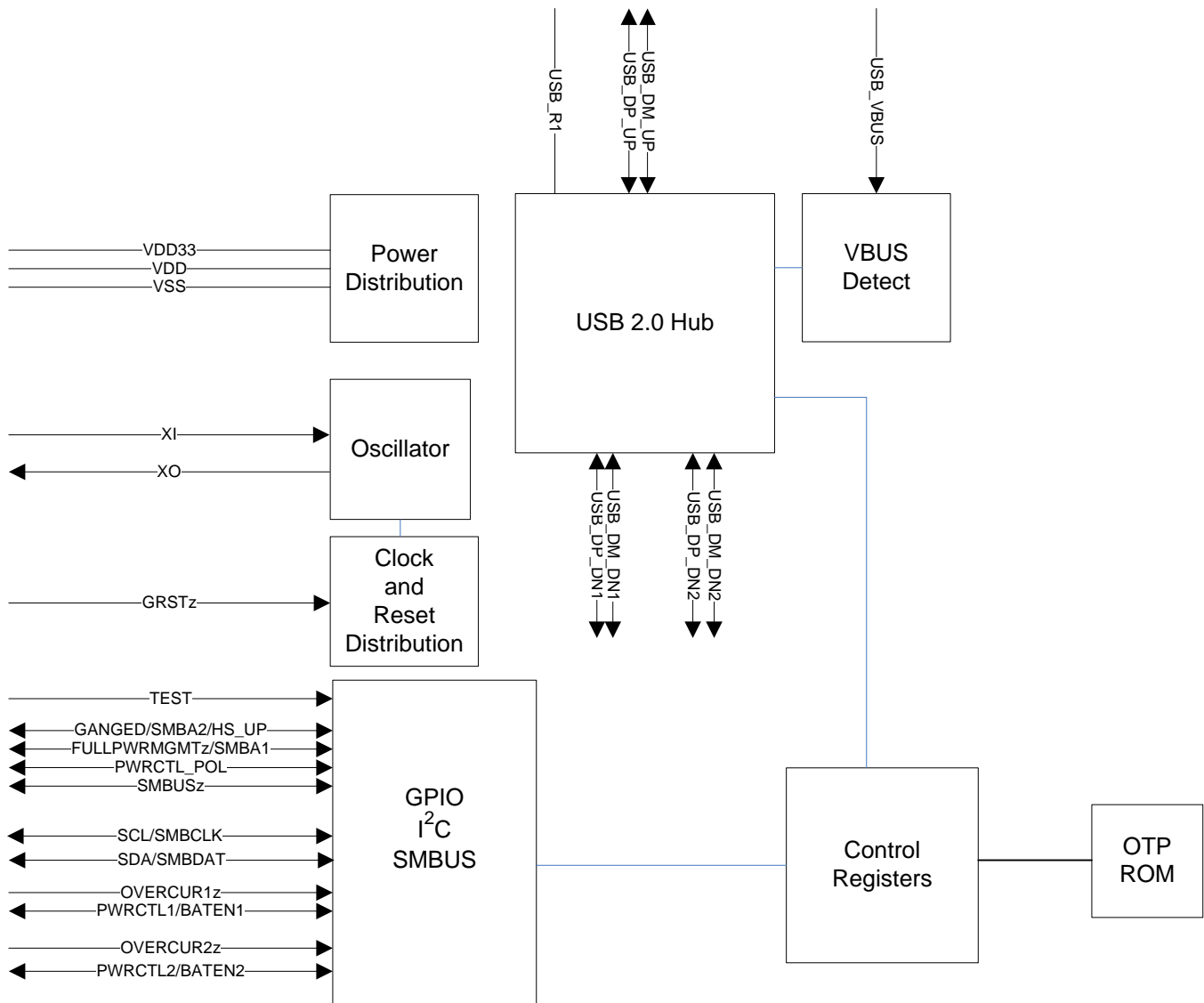

8.3 Feature Description

8.3.1 Battery Charging Features

The TUSB4020BI-Q1 provides support for battery charging. Battery charging support may be enabled on a per port basis through the REG_6h(batEn[1:0]).

Battery charging support includes both charging downstream port (CDP) and dedicated charging port (DCP) modes. The DCP mode is compliant with the Chinese Telecommunications Industry Standard YD/T 1591-2009.

In addition to standard DCP mode, the TUSB4020BI-Q1 provides a mode (AUTOMODE) which automatically provides support for DCP devices and devices that support custom charging indication. AUTOMODE is disabled by default. When in AUTOMODE, the port automatically switches between a divider mode and the DCP mode depending on the portable device connected. The divider mode places a fixed DC voltage on the ports DP and DM signals which allows some devices to identify the capabilities of the charger. The default divider mode indicates support for up to 5 W. The divider mode can be configured to report a high-current setting (up to 10 W) through REG_Ah(HiCurAcpModeEn). When AUTOMODE is enabled through REG_Ah(autoModeEnz), the CDP mode is not functional. CDP mode can not be used when AUTOMODE is enabled.

The battery charging mode for each port depends on the state of Reg_6h(batEn[n]), the status of the VBUS input, and the state of REG_Ah(autoModeEnz) upstream port, as identified in [Table 1](#). Battery charging can also be enabled through the PWRCTL1/BATEN1 and PWRCTL2/BATEN2 pins.

Table 1. TUSB4020BI-Q1 Battery Charging Modes

batEn[n]	VBUS	autoModeEnz	BC Mode Port x (x = n + 1)
0	Don't care	Don't care	Don't care
1	<4 V	0	Automode ⁽¹⁾ ⁽²⁾
		1	DCP ⁽³⁾ ⁽⁴⁾
	>4 V	1	CDP ⁽³⁾

(1) Auto-mode automatically selects divider-mode or DCP mode.

(2) Divider mode can be configured for high-current mode through register or OTP settings.

(3) USB device is USB Battery Charging Specification Revision 1.2 Compliant

(4) USB device is Chinese Telecommunications Industry Standard YD/T 1591-2009

8.3.2 USB Power Management

The TUSB4020BI-Q1 can be configured for power switched applications using either per-port or ganged power-enable controls and overcurrent status inputs.

Power switch support is enabled by REG_5h(fullPwrMgmtz) and the per-port or ganged mode is configured by REG_5h(ganged). It can also be enabled through the FULLPWRMGMTz pin. Also ganged or individual control can be controlled by the GANGED pin.

The TUSB4020BI-Q1 supports both active-high and active-low power-enable controls. The PWRCTL[2:1] polarity is configured by REG_Ah(pwrctlPol). The polarity can also be configured by the PWRCTL_POL pin.

8.3.3 Clock Generation

The TUSB4020BI-Q1 accepts a crystal input to drive an internal oscillator or an external clock source. If a crystal is used, a 1-MΩ shunt resistor is required. Keep the XI and XO traces as short as possible and away from any switching leads to minimize noise coupling.

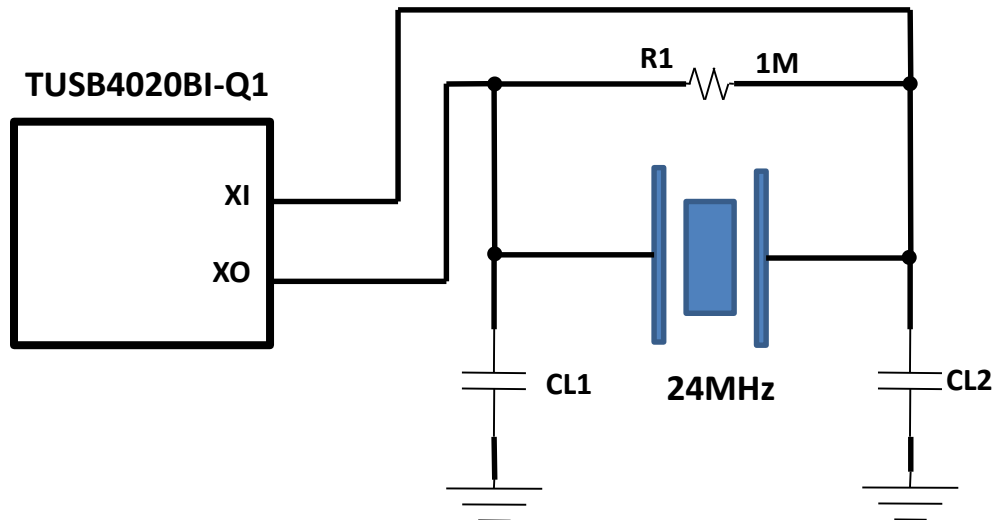

Figure 2. TUSB4020BI-Q1 Clock

8.3.4 Power-Up and Reset

The TUSB4020BI-Q1 does not have specific power sequencing requirements with respect to the VDD or VDD33 power rails. The VDD or VDD33 power rails may be powered up for an indefinite period of time while the other is not powered up if all of these constraints are met:

- All maximum ratings and recommended operating conditions are observed.
- All warnings about exposure to maximum rated and recommended conditions are observed, particularly junction temperature. These apply to power transitions as well as normal operation.
- Bus contention while VDD33 is powered-up must be limited to 100 hours over the projected lifetime of the device.
- Bus contention while VDD33 is powered-down may violate the absolute maximum ratings.

A supply bus is powered up when the voltage is within the recommended operating range. A supply bus is powered down when it is below that range, either stable or in transition.

A minimum reset duration of 3 ms is required, which is defined as the time when the power supplies are in the recommended operating range to the deassertion of GRSTz. This can be generated using programmable-delay supervisory device or using an RC circuit.

8.4 Device Functional Modes

8.4.1 External Configuration Interface

The TUSB4020BI-Q1 supports a serial interface for configuration register access. The device may be configured by an attached I²C EEPROM or accessed as a slave by a SMBus-capable host controller. The external interface is enabled when both the SCL/SMBCLK and SDA/SMBDAT terminals are pulled up to 3.3 V at the deassertion of reset. The mode, I²C master, or SMBus slave is determined by the state of SMBUSz terminal at reset.

8.5 Programming

8.5.1 One-Time Programmable (OTP) Configuration

The TUSB4020BI-Q1 allows device configuration through OTP non-volatile memory (OTP). The programming of the OTP is supported using vendor-defined USB device requests. For details using the OTP features, contact your TI representative.

[Table 2](#) provides a list features which may be configured using the OTP. The bit field section in [Table 2](#) shows which features can be controlled by OTP ROM. The bits not listed in the table are not accessible by the OTP ROM.

Table 2. OTP Configurable Features

CONFIGURATION REGISTER OFFSET	BIT FIELD	DESCRIPTION
REG_01h	[7:0]	Vendor ID LSB
REG_02h	[7:0]	Vendor ID MSB
REG_03h	[7:0]	Product ID LSB
REG_04h	[7:0]	Product ID MSB
REG_07h	[0]	Port removable configuration for downstream ports 1. OTP configuration is inverse of rmb[1:0], that is: 1 = Not removable 0 = Removable
REG_07h	[1]	Port removable configuration for downstream ports 2. OTP configuration is inverse of rmb[1:0], that is: 1 = Not removable 0 = Removable
REG_0Ah	[1]	Automode enable
REG_0Ah	[4]	High-current divider mode enable.
REG_F2h	[3:1]	USB power switch power-on delay.

8.5.2 I²C EEPROM Operation

The TUSB4020BI-Q1 supports a single-master, standard mode (100 kbit/s) connection to a dedicated I²C EEPROM when the I²C interface mode is enabled. In I²C mode, the TUSB4020BI-Q1 reads the contents of the EEPROM at bus address 1010000b using 7-bit addressing starting at address 0.

If the value of the EEPROM contents at byte 00h equals 55h, the TUSB4020BI-Q1 loads the configuration registers according to the EEPROM map. If the first byte is not 55h, the TUSB4020BI-Q1 exits the I²C mode and continues execution with the default values in the configuration registers. The hub will not connect on the upstream port until the configuration is completed. If the TUSB4020BI-Q1 detects an unprogrammed EEPROM (value other than 55h), it enters programming mode and a programming endpoint within the hub is enabled.

Note, the bytes located above offset Ah are optional. The requirement for data in those addresses depends on the options configured in the Device Configuration, Phy Custom Configuration, and Device Configuration 2 registers.

For details on I²C operation, refer to the UM10204 I²C-bus Specification and User Manual.

8.5.3 SMBus Slave Operation

When the SMBus interface mode is enabled, the TUSB4020BI-Q1 supports read block and write block protocols as a slave-only SMBus device.

The TUSB4020BI-Q1 slave address is 1000 1xyz, where:

- x is the state of GANGED/SMBA2/HS_UP terminal at reset
- y is the state of FULLPWRMGMTz/SMBA1 terminal at reset
- z is the read/write bit; 1 = read access, 0 = write access.

If the TUSB4020BI-Q1 is addressed by a host using an unsupported protocol, it does not respond. The TUSB4020BI-Q1 waits indefinitely for configuration by the SMBus host and does not connect on the upstream port until the SMBus host indicates configuration is complete by clearing the CFG_ACTIVE bit.

For details on SMBus requirements, refer to the System Management Bus Specification.

8.6 Register Maps

8.6.1 Configuration Registers

The internal configuration registers are accessed on byte boundaries. The configuration register values are loaded with defaults but can be overwritten when the TUSB4020BI-Q1 is in I²C or SMBus mode.

Table 3. TUSB4020BI-Q1 Register Map

BYTE ADDRESS	CONTENTS	EEPROM CONFIGURABLE
00h	ROM Signature Register	No
01h	Vendor ID LSB	Yes
02h	Vendor ID MSB	Yes
03h	Product ID LSB	Yes
04h	Product ID MSB	Yes
05h	Device Configuration Register	Yes
06h	Battery Charging Support Register	Yes
07h	Device Removable Configuration Register	Yes
08h	Port Used Configuration Register	Yes
09h	Reserved	Yes, program to 00h
0Ah	Device Configuration Register 2	Yes
0Bh to 0Fh	Reserved	
10h to 1Fh	UUID Byte [15:0]	No
20h to 21h	LangID Byte [1:0]	Yes, if customStrings is set
22h	Serial Number String Length	Yes, if customSerNum is set
23h	Manufacturer String Length	Yes, if customStrings is set
24h	Product String Length	Yes, if customStrings is set
25h to 2Fh	Reserved	Yes
30h to 4Fh	Serial Number String Byte [31:0]	Yes, if customSerNum is set
50h to 8Fh	Manufacturer String Byte [63:0]	Yes, if customStrings is set
90h to CFh	Product String Byte [63:0]	Yes, if customStrings is set
D0 to DFh	Reserved	No
F0h	Additional Feature Configuration Register	Yes
F1h	Reserved	Yes
F2h	Charging Port Control Register	Yes
F3 to F7h	Reserved	No
F8h	Device Status and Command Register	No
F9 to FFh	Reserved	No

8.6.1.1 ROM Signature Register (offset = 0h) [reset = 0h]

Figure 3. Register Offset 0h

7	6	5	4	3	2	1	0
0	0	0	0	0	0	0	0
R/W	R/W	R/W	R/W	R/W	R/W	R/W	R/W

LEGEND: R/W = Read/Write; R = Read only; –n = value after reset

Table 4. ROM Signature Register

Bit	Field	Type	Reset	Description
7:0	romSignature	R/W	0h	ROM Signature Register. This register is used by the TUSB4020BI-Q1 in I ² C mode to validate the attached EEPROM has been programmed. The first byte of the EEPROM is compared to the mask 55h and if not a match, the TUSB4020BI-Q1 aborts the EEPROM load and executes with the register defaults.

8.6.1.2 Vendor ID LSB Register (offset = 1h) [reset = 51h]

Figure 4. Register Offset 51h

7	6	5	4	3	2	1	0
0	1	0	1	0	0	0	1
R/W	R/W	R/W	R/W	R/W	R/W	R/W	R/W

LEGEND: R/W = Read/Write; R = Read only; –n = value after reset

Table 5. Vendor ID LSB Register

Bit	Field	Type	Reset	Description
7:0	vendorIdLsb	R/W	51h	Vendor ID LSB. Least significant byte of the unique vendor ID assigned by the USB-IF; the default value of this register is 51h representing the LSB of the TI Vendor ID 0451h. The value may be overwritten to indicate a customer vendor ID. This field is read/write unless the OTP ROM VID and OTP ROM PID values are non-zero. If both values are non-zero, the value when reading this register shall reflect the OTP ROM value.

8.6.1.3 Vendor ID MSB Register (offset = 2h) [reset = 4h]

Figure 5. Register Offset 2h

7	6	5	4	3	2	1	0
0	0	0	0	0	1	0	0
R/W	R/W	R/W	R/W	R/W	R/W	R/W	R/W

LEGEND: R/W = Read/Write; R = Read only; –n = value after reset

Table 6. Vendor ID MSB Register

Bit	Field	Type	Reset	Description
7:0	vendorIdMsb	R/W	4h	Vendor ID MSB. Most significant byte of the unique vendor ID assigned by the USB-IF; the default value of this register is 04h representing the MSB of the TI Vendor ID 0451h. The value may be overwritten to indicate a customer vendor ID. This field is read/write unless the OTP ROM VID and OTP ROM PID values are non-zero. If both values are non-zero, the value when reading this register shall reflect the OTP ROM value.

8.6.1.4 Product ID LSB Register (offset = 3h) [reset = 25h]
Figure 6. Register Offset 3h

7	6	5	4	3	2	1	0
0	0	1	0	0	1	0	1
R/W	R/W	R/W	R/W	R/W	R/W	R/W	R/W

LEGEND: R/W = Read/Write; R = Read only; –n = value after reset

Table 7. Product ID LSB Register

Bit	Field	Type	Reset	Description
7:0	productIdLsb	R/W	25h	Product ID LSB. Least significant byte of the product ID assigned by TI. The default value of this register is 25h representing the LSB of the product ID assigned by TI. The value reported in the USB 2.0 device descriptor is the value of this register bit wise XORed with 00000010b. The value may be overwritten to indicate a customer product ID. This field is read/write unless the OTP ROM VID and OTP ROM PID values are non-zero. If both values are non-zero, the value when reading this register shall reflect the OTP ROM value.

8.6.1.5 Product ID MSB Register (offset = 4h) [reset = 80h]
Figure 7. Register Offset 4h

7	6	5	4	3	2	1	0
1	0	0	0	0	0	0	0
R/W	R/W	R/W	R/W	R/W	R/W	R/W	R/W

LEGEND: R/W = Read/Write; R = Read only; –n = value after reset

Table 8. Bit Descriptions – Product ID MSB Register

Bit	Field	Type	Reset	Description
7:0	productIdLsb	R/W	80h	Product ID MSB. Most significant byte of the product ID assigned by TI; the default value of this register is 80h representing the MSB of the product ID assigned by TI. The value may be overwritten to indicate a customer product ID. This field is read/write unless the OTP ROM VID and OTP ROM PID values are non-zero. If both values are non-zero, the value when reading this register will reflect the OTP ROM value.

8.6.1.6 Device Configuration Register (offset = 5h) [reset = 1Xh]
Figure 8. Register Offset 5h

7	6	5	4	3	2	1	0
0	0	0	1	X	X	0	0
R/W	R/W	R/W	R	R/W	R/W	R/W	R

LEGEND: R/W = Read/Write; R = Read only; –n = value after reset

Table 9. Device Configuration Register

Bit	Field	Type	Reset	Description
7	customStrings	R/W	1Xh	Custom strings enable. This bit controls the ability to write to the Manufacturer String Length, Manufacturer String, Product String Length, Product String, and Language ID registers. 0 = The Manufacturer String Length, Manufacturer String, Product String Length, Product String, and Language ID registers are read only. 1 = The Manufacturer String Length, Manufacturer String, Product String Length, Product String, and Language ID registers may be loaded by EEPROM or written by SMBus. The default value of this bit is 0.
6	customSernum	R/W	1Xh	Custom serial number enable. This bit controls the ability to write to the serial number registers. 0 = The Serial Number String Length and Serial Number String registers are read only. 1 = The Serial Number String Length and Serial Number String registers may be loaded by EEPROM or written by SMBus. The default value of this bit is 0.
5	RSVD	R/W	1Xh	Reserved. This bit is reserved.
4	RSVD	R	1Xh	Reserved. This bit is reserved and returns 1 when read.
3	ganged	R/W	1Xh	Ganged. This bit is loaded at the deassertion of reset with the value of the GANGED/SMBA2/HS_UP terminal. 0 = When fullPwrMgmtz = 0, each port is individually power switched and enabled by the PWRCTL[2:1]/BATEN[2:1] terminals 1 = When fullPwrMgmtz = 0, the power switch control for all ports is ganged and enabled by the PWRCTL1/BATEN1 terminal When the TUSB4020BI-Q1 is in I ² C mode, the TUSB4020BI-Q1 loads this bit from the contents of the EEPROM. When the TUSB4020BI-Q1 is in SMBUS mode, the value may be overwritten by an SMBus host.
2	fullPwrMgmtz	R/W	1Xh	Full Power Management. This bit is loaded at the deassertion of reset with the value of the FULLPWRMGMTz/SMBA1 terminal. 0 = Port power switching and over-current status reporting is enabled 1 = Port power switching and over-current status reporting is disabled When the TUSB4020BI-Q1 is in I ² C mode, the TUSB4020BI-Q1 loads this bit from the contents of the EEPROM. When the TUSB4020BI-Q1 is in SMBUS mode, the value may be overwritten by an SMBus host.
1	RSVD	R/W	1Xh	Reserved. This bit is reserved and should not be altered from the default.
0	RSVD	R	1Xh	Reserved. This field is reserved and returns 0 when read.

8.6.1.7 Battery Charging Support Register (offset = 6h) [reset = 0Xh]
Figure 9. Register Offset 6h

7	6	5	4	3	2	1	0
0	0	0	0	0	0	X	X
R	R/W	R/W	R/W	R/W	R/W	R/W	R/W

LEGEND: R/W = Read/Write; R = Read only; –n = value after reset

Table 10. Battery Charging Support Register

Bit	Field	Type	Reset	Description
7:2	RSVD	R	0Xh	Reserved. Read only, returns 0 when read.
1:0	batEn[1:0]	R/W	0Xh	Battery Charger Support. The bits in this field indicate whether the downstream port implements the charging port features. 0 = The port is not enabled for battery charging support features 1 = The port is enabled for battery charging support features Each bit corresponds directly to a downstream port, that is batEn0 corresponds to downstream port 1, and batEN1 corresponds to downstream port 2. The default value for these bits are loaded at the deassertion of reset with the value of PWRCTL/BATEN[1:0]. When in I2C/SMBus mode the bits in this field may be overwritten by EEPROM contents or by an SMBus host.

8.6.1.8 Device Removable Configuration Register (offset = 7h) [reset = 0Xh]
Figure 10. Register Offset 7h

7	6	5	4	3	2	1	0
0	0	0	0	0	0	X	X
R/W	R	R	R	R	R	R	R/W

LEGEND: R/W = Read/Write; R = Read only; –n = value after reset

Table 11. Device Removable Configuration Register

Bit	Field	Type	Reset	Description
7	customRmbl	R/W	0Xh	Custom removable status. When this field is a 1, the TUSB4020BI-Q1 uses rmb1 bits in this register to identify removable status for the ports.
6:2	RSVD	R	0Xh	Reserved. Read only, returns 0 when read. Bits 3:2 are RW. They are reserved and return 0 when read.
1:0	rmb1[1:0]	R/W	0Xh	Removable. The bits in this field indicate whether a device attached to downstream ports 2 through 1 are removable or permanently attached. 0 = The device attached to the port is not removable 1 = The device attached to the port is removable Each bit corresponds directly to a downstream port n + 1, that is rmb10 corresponds to downstream port 1, rmb11 corresponds to downstream port 2, and so forth. This field is read only unless the customRmbl bit is set to 1. Otherwise the value of this field reflects the inverted values of the OTP ROM non_rmb[1:0] field.

8.6.1.9 Port Used Configuration Register (offset = 8h) [reset = 0h]
Figure 11. Register Offset 8h

7	6	5	4	3	2	1	0
0	0	0	0	0	0	1	1
R	R	R	R	R	R	R	R

LEGEND: R/W = Read/Write; R = Read only; –n = value after reset

Table 12. Port Used Configuration Register

Bit	Field	Type	Reset	Description
7:0	RSVD	R	0h	Reserved. Read only.

8.6.1.10 PHY Custom Configuration Register (offset = 9h) [reset = 0h]
Figure 12. Register Offset 9h

7	6	5	4	3	2	1	0
0	0	0	0	0	0	1	1
R	R	R/W	R	R	R	R/W	R/W

LEGEND: R/W = Read/Write; R = Read only; –n = value after reset

Table 13. PHY Custom Configuration Register

Bit	Field	Type	Reset	Description
7:6	RSVD	R	0h	Reserved. Read only, returns 0 when read.
5	RSVD	R/W	0h	Reserved. This bit is reserved and should not be altered from the default.
4:2	RSVD	R	0h	Reserved. Read only, returns 0 when read.
1:0	RSVD	R/W	0h	Reserved. This field is reserved and should not be altered from the default.

8.6.1.11 Device Configuration Register 2 (offset = Ah)
Figure 13. Register Offset Ah

7	6	5	4	3	2	1	0
0	0	X	0	0	0	0	0
R	RW	RW	RW	RW	RW	RW	R

LEGEND: R/W = Read/Write; R = Read only; –n = value after reset

Table 14. Bit Descriptions – Device Configuration Register 2

Bit	Field Name	Access	Reset	Description
7	RSVD	RO		Reserved. Read only, returns 0 when read.
6	customBCfeatures	RW		<p>Custom Battery Charging Feature Enable. This bit controls the ability to write to the battery charging feature configuration controls.</p> <p>0 = The HiCurAcpModeEn and AutoModeEnz bits are read only and the values are loaded from the OTP ROM.</p> <p>1 = The HiCurAcpModeEn and AutoModeEnz bits are read/write and can be loaded by EEPROM or written by SMBus. from this register.</p> <p>This bit may be written simultaneously with HiCurAcpModeEn and AutoModeEnz.</p>
5	pwrctlPol	RW		<p>Power enable polarity. This bit is loaded at the deassertion of reset with the inverse value of the PWRCTL_POL terminal.</p> <p>0 = PWRCTL polarity is active low</p> <p>1 = PWRCTL polarity is active high</p> <p>When the TUSB4020BI-Q1 is in I²C mode, the TUSB4020BI-Q1 loads this bit from the contents of the EEPROM.</p> <p>When the TUSB4020BI-Q1 is in SMBUS mode, the value may be overwritten by an SMBus host.</p>
4	HiCurAcpModeEn	RO/RW		<p>High-current ACP mode enable. This bit enables the high-current tablet charging mode when the automatic battery charging mode is enabled for downstream ports.</p> <p>0 = High current divider mode disabled</p> <p>1 = High current divider mode enabled</p> <p>This bit is read only unless the customBCfeatures bit is set to 1. Otherwise the value of this bit reflects the value of the OTP ROM HiCurAcpModeEn bit.</p>
3	RSVD	RW		Reserved
2	dsportEcrEn	RW		<p>DSPort ECR enable. This bit enables full implementation of the DSPort ECR (April 2013).</p> <p>0 = DSPort ECR (April 2013) is enabled with the exception of changes related to the CCS bit is set upon entering U0, and changes related to avoiding or reporting compliance mode entry.</p> <p>1 = The full DSPort ECR (April 2013) is enabled.</p>
1	autoModeEnz	RO/RW		<p>Automatic Mode Enable. This bit is loaded from the OTP ROM.</p> <p>The automatic mode only applies to downstream ports with battery charging enabled when the upstream port is not connected. Under these conditions:</p> <p>0 = Automatic mode battery charging features are enabled. Only battery charging DCP and custom BC (divider mode) is enabled.</p> <p>1 = Automatic mode is disabled; only battery charging DCP and CDP mode is supported.</p> <p>Note: When the upstream port is connected, battery charging CDP mode is supported on all ports when this field is one.</p> <p>This bit is read only unless the customBCfeatures bit is set to 1. Otherwise the value of this bit reflects the value of the OTP ROM AutoModeEnz bit.</p>
0	RSVD	RO		Reserved. Read only, returns 0 when read.

8.6.1.12 UUID Registers (offset = 10h to 1Fh)
Figure 14. Register Offset 10h to 1Fh

7	6	5	4	3	2	1	0
X	X	X	X	X	X	X	X
R	R	R	R	R	R	R	R

LEGEND: R/W = Read/Write; R = Read only; –n = value after reset

Table 15. Bit Descriptions – UUID Byte N Register

Bit	Field Name	Access	Reset	Description
7:0	uuidByte[n]	RO		UUID byte N. The UUID returned in the Container ID descriptor. The value of this register is provided by the device and is meets the UUID requirements of Internet Engineering Task Force (IETF) RFC 4122 A UUID URN Namespace.

8.6.1.13 Language ID LSB Register (offset = 20h)
Figure 15. Register Offset 20h

7	6	5	4	3	2	1	0
0	0	0	0	1	0	0	1
R/W	R/W	R/W	R/W	R/W	R/W	R/W	R/W

LEGEND: R/W = Read/Write; R = Read only; –n = value after reset

Table 16. Bit Descriptions – Language ID LSB Register

Bit	Field Name	Access	Reset	Description
7:0	langIdLsb	RW		Language ID least significant byte. This register contains the value returned in the LSB of the LANGID code in string index 0. The TUSB4020BI-Q1 only supports one language ID. The default value of this register is 09h representing the LSB of the LangID 0409h indicating English United States. When customStrings is 1, this field may be overwritten by the contents of an attached EEPROM or by an SMBus host.

8.6.1.14 Language ID MSB Register (offset = 21h)
Figure 16. Register Offset 21h

7	6	5	4	3	2	1	0
0	0	0	0	0	1	0	0
R/W	R/W	R/W	R/W	R/W	R/W	R/W	R/W

LEGEND: R/W = Read/Write; R = Read only; –n = value after reset

Table 17. Bit Descriptions – Language ID MSB Register

Bit	Field Name	Access	Reset	Description
7:0	langIdMsB	RO/RW		Language ID most significant byte. This register contains the value returned in the MSB of the LANGID code in string index 0. The TUSB4020BI-Q1 only supports one language ID. The default value of this register is 04h representing the MSB of the LangID 0409h indicating English United States. When customStrings is 1, this field may be overwritten by the contents of an attached EEPROM or by an SMBus host.

8.6.1.15 Serial Number String Length Register (offset = 22h)
Figure 17. Register Offset 22h

7	6	5	4	3	2	1	0
0	0	0	1	1	0	0	0
R/W	R/W	R/W	R/W	R/W	R/W	R/W	R/W

LEGEND: R/W = Read/Write; R = Read only; –n = value after reset

Table 18. Bit Descriptions – Serial Number String Length Register

Bit	Field Name	Access	Reset	Description
7:6	RSVD	RO		Reserved. Read only, returns 0 when read.
5:0	serNumStringLen	RO/RW		Serial number string length. The string length in bytes for the serial number string. The default value is 18h indicating that a 24-byte serial number string is supported. The maximum string length is 32 bytes. When customSernum is 1, this field may be overwritten by the contents of an attached EEPROM or by an SMBus host. When the field is non-zero, a serial number string of serNumbStringLength bytes is returned at string index 1 from the data contained in the Serial Number String registers.

8.6.1.16 Manufacturer String Length Register (offset = 23h)
Figure 18. Register Offset 23h

7	6	5	4	3	2	1	0
0	0	0	0	0	0	0	0
R	R/W	R/W	R/W	R/W	R/W	R/W	R/W

LEGEND: R/W = Read/Write; R = Read only; –n = value after reset

Bit Descriptions – Manufacturer String Length Register

Bit	Field Name	Access	Reset	Description
7	RSVD	RO		Reserved. Read only, returns 0 when read.
6:0	mfgStringLen	RO/RW		Manufacturer string length. The string length in bytes for the manufacturer string. The default value is 0, indicating that a manufacturer string is not provided. The maximum string length is 64 bytes. When customStrings is 1, this field may be overwritten by the contents of an attached EEPROM or by an SMBus host. When the field is non-zero, a manufacturer string of mfgStringLen bytes is returned at string index 3 from the data contained in the Manufacturer String registers.

8.6.1.17 Product String Length Register (offset = 24h)
Figure 19. Register Offset 24h

7	6	5	4	3	2	1	0
0	0	0	0	0	0	0	0
R	R/W	R/W	R/W	R/W	R/W	R/W	R/W

LEGEND: R/W = Read/Write; R = Read only; –n = value after reset

Bit Descriptions – Product String Length Register

Bit	Field Name	Access	Reset	Description
7	RSVD	RO		Reserved. Read only, returns 0 when read.
6:0	prodStringLength	RO/RW		Product string length. The string length in bytes for the product string. The default value is 0, indicating that a product string is not provided. The maximum string length is 64 bytes. When customStrings is 1, this field may be overwritten by the contents of an attached EEPROM or by an SMBus host. When the field is non-zero, a product string of prodStringLength bytes is returned at string index 2 from the data contained in the Product String registers.

8.6.1.18 Serial Number Registers (offset = 30h to 4Fh)

Figure 20. Register Offset 30h to 4Fh

7	6	5	4	3	2	1	0
X	X	x	x	x	x	x	x
R/W	R/W	R/W	R/W	R/W	R/W	R/W	R/W

LEGEND: R/W = Read/Write; R = Read only; –n = value after reset

Table 19. Bit Descriptions – Serial Number Registers

Bit	Field Name	Access	Reset	Description
7:0	serialNumber[n]	RO/RW		Serial Number byte N. The serial number returned in the Serial Number string descriptor at string index 1. The default value of these registers is set by T1. When customSernum is 1, these registers may be overwritten by EEPROM contents or by an SMBus host.

8.6.1.19 Manufacturer String Registers (offset = 50h to 8Fh)

Figure 21. Register Offset 50h to 8Fh

7	6	5	4	3	2	1	0
0	0	0	0	0	0	0	0
R/W	R/W	R/W	R/W	R/W	R/W	R/W	R/W

LEGEND: R/W = Read/Write; R = Read only; –n = value after reset

Table 20. Bit Descriptions – Manufacturer String Registers

Bit	Field Name	Access	Reset	Description
7:0	mfgStringByte[n]	RO/RW		Manufacturer string byte N. These registers provide the string values returned for string index 3 when mfgStringLen is greater than 0. The number of bytes returned in the string is equal to mfgStringLen. The programmed data should be in UNICODE UTF-16LE encodings as defined by The Unicode Standard, Worldwide Character Encoding, Version 5.0.

8.6.1.20 Product String Registers (offset = 90h to CFh)

Figure 22. Register Offset 90h to CFh

7	6	5	4	3	2	1	0
0	0	0	0	0	0	0	0
R/W	R/W	R/W	R/W	R/W	R/W	R/W	R/W

LEGEND: R/W = Read/Write; R = Read only; –n = value after reset

Table 21. Bit Descriptions – Product String Byte N Register

Bit	Field Name	Access	Reset	Description
7:0	prodStringByte[n]	RW		Product string byte N. These registers provide the string values returned for string index 2 when prodStringLen is greater than 0. The number of bytes returned in the string is equal to prodStringLen. The programmed data should be in UNICODE UTF-16LE encodings as defined by The Unicode Standard, Worldwide Character Encoding, Version 5.0.

8.6.1.21 Additional Feature Configuration Register (offset = F0h)
Figure 23. Register Offset F0h

7	6	5	4	3	2	1	0
0	0	0	0	0	0	0	0
R	R/W	R/W	R/W	R/W	R/W	R/W	R/W

LEGEND: R/W = Read/Write; R = Read only; –n = value after reset

Table 22. Bit Descriptions – Additional Feature Configuration Register

Bit	Field Name	Access	Reset	Description
7:1	RSVD	RO		Reserved. Read only, returns 0 when read.
0	RSVD	RW		Reserved This bit is loaded at the deassertion of reset with the value of the SCL/SMBCLK terminal.

8.6.1.22 Charging Port Control Register (offset = F2h)
Figure 24. Register Offset F2h

7	6	5	4	3	2	1	0
0	0	0	0	0	0	0	0
R	R	R	R	R/W	R/W	R/W	R/W

LEGEND: R/W = Read/Write; R = Read only; –n = value after reset

Table 23. Bit Descriptions – Charging Port Control Register

Bit	Field Name	Access	Reset	Description
7:4	RSVD	RO		Reserved. Read only, returns 0 when read.
3:1	pwronTime	RW		Power-On Delay Time. When dsportEcrEn is set, this field sets the delay time from the removal disable of PWRCTL to the enable of PWRCTL when transitioning battery charging modes. For example, when disabling the power on a transition from custom charging mode to Dedicated Charging Port Mode. The nominal timing is defined as follows: $TPWRON_EN = (pwronTime + 1) \times 200 \text{ ms}$ (1) These registers may be overwritten by EEPROM contents or by an SMBus host.
0	RSVD	RW		Reserved. This bit is reserved and should not be altered from the default.

8.6.1.23 Device Status and Command Register (offset = F8h)
Figure 25. Register Offset F8h

7	6	5	4	3	2	1	0
0	0	0	0	0	0	0	0
R	R	R	R	R	R	RSU	RCU

LEGEND: R/W = Read/Write; R = Read only; –n = value after reset

Table 24. Bit Descriptions – Device Status and Command Register

Bit	Field Name	Access	Reset	Description
7:2	RSVD	R		Reserved. Read only, returns 0 when read.
1	smbusRst	RSU		SMBus interface reset. This bit loads the registers back to their GRSTz values. This bit is set by writing a 1 and is cleared by hardware on completion of the reset. A write of 0 has no effect.
0	cfgActive	RCU		Configuration active. This bit indicates that configuration of the TUSB4020BI-Q1 is currently active. The bit is set by hardware when the device enters the I ² C or SMBus mode. The TUSB4020BI-Q1 will not connect on the upstream port while this bit is 1. When in the SMBus mode, this bit must be cleared by the SMBus host to exit the configuration mode and allow the upstream port to connect. The bit is cleared by a writing 1. A write of 0 has no effect.

9 Application and Implementation

NOTE

Information in the following applications sections is not part of the TI component specification, and TI does not warrant its accuracy or completeness. TI's customers are responsible for determining suitability of components for their purposes. Customers should validate and test their design implementation to confirm system functionality.

9.1 Application Information

The TUSB4020BI-Q1 is a two-port USB 2.0 hub. It provides USB high-speed/full-speed connections on the upstream port and provides USB high-speed, full-speed, or low-speed connections on the downstream port. The TUSB4020BI-Q1 can be used in any application that needs additional USB compliant ports. For example, a specific notebook may only have two downstream USB ports. By using the TUSB4020BI-Q1, the notebook can increase the downstream port count to three.

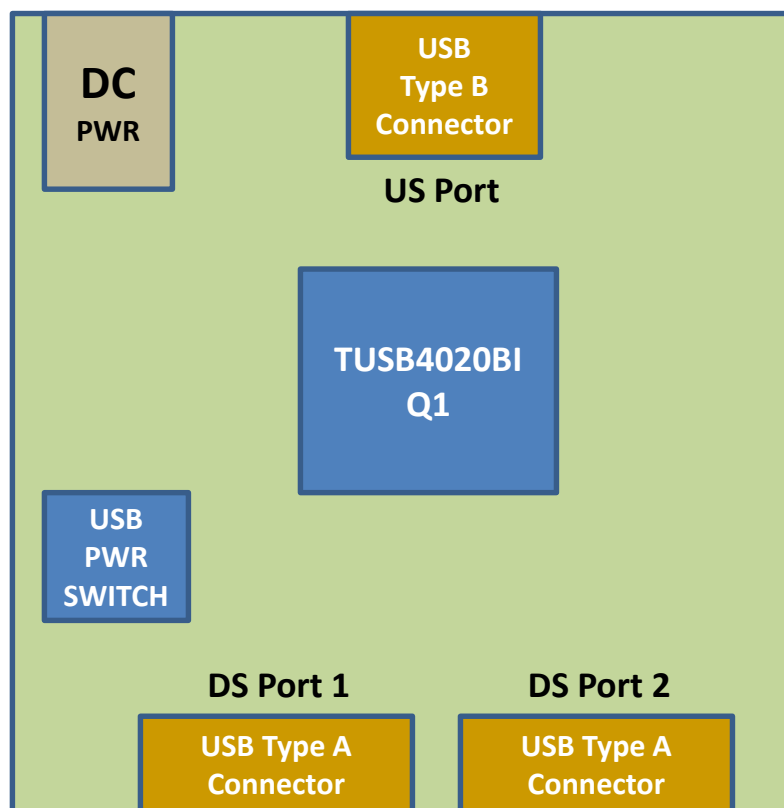

Figure 26. Discrete USB Hub Product

9.1.1 Crystal Requirements

The crystal must be fundamental mode with load capacitance of 12 to 24 pF and frequency stability rating of ± 100 PPM or better. To ensure proper startup oscillation condition, TI recommends a maximum crystal equivalent series resistance (ESR) of 50 Ω . A parallel load capacitor should be used if a crystal source is used. The exact load capacitance value used depends on the crystal vendor. Refer to application note *Selection and Specification of Crystals for Texas Instruments USB 2.0 Devices* (SLLA122) for details on how to determine the load capacitance value.

Application Information (continued)

9.1.2 Input Clock Requirements

When using an external clock source such as an oscillator, the reference clock should have a ± 100 PPM or better frequency stability and have less than 50-ps absolute peak-to-peak jitter. XI should be tied to the 1.8-V clock source and XO should be left floating.

9.2 Typical Applications

A common application for the TUSB4020BI-Q1 is as a self-powered standalone USB hub product. The product is powered by an external 5-V DC power adapter. In this application using a USB cable, TUSB4020BI-Q1 device's upstream port is plugged into a USB host controller. The downstream ports of the TUSB4020BI-Q1 are exposed to users for connecting USB hard drives, camera, flash drive, and so forth.

9.2.1 Upstream Port Implementation

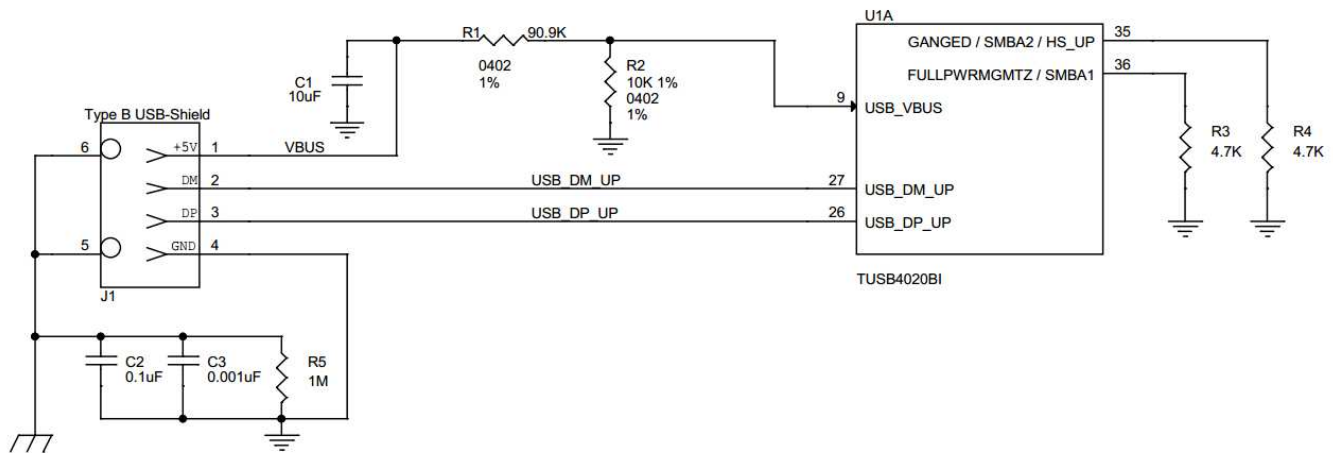

Figure 27. Upstream Port Implementation Schematic

9.2.1.1 Design Requirements

Table 25. Input Parameters

DESIGN PARAMETER	EXAMPLE VALUE
VDD supply	1.1 V
VDD33 supply	3.3 V
Upstream port USB support (HS, FS)	HS, FS
Downstream port 1 USB support (HS, FS, LS)	HS, FS, LS
Downstream port 2 USB support (HS, FS, LS)	HS, FS, LS
Number of removable downstream ports	2
Number of non-removable downstream ports	0
Full power management of downstream ports	Yes (FULLPWRMGMTZ = 0)
Individual control of downstream port power switch	Yes (GANGED = 0)
Power switch enable polarity	Active high (PWRCTL_POL = 0)
Battery charge support for downstream port 1	Yes
Battery charge support for downstream port 2	Yes
I ² C EEPROM support	No
24-MHz clock source	Crystal

9.2.1.2 Detailed Design Procedure

The upstream of the TUSB4020BI-Q1 is connected to a USB2 type B connector. This particular example has GANGED terminal and FULLPWRMGMTZ terminal pulled low, which results in individual power support each downstream port. The VBUS signal from the USB2 type B connector is fed through a voltage divider. The purpose of the voltage divider is to make sure the level meets USB_VBUS input requirements.

9.2.1.3 Application Curves

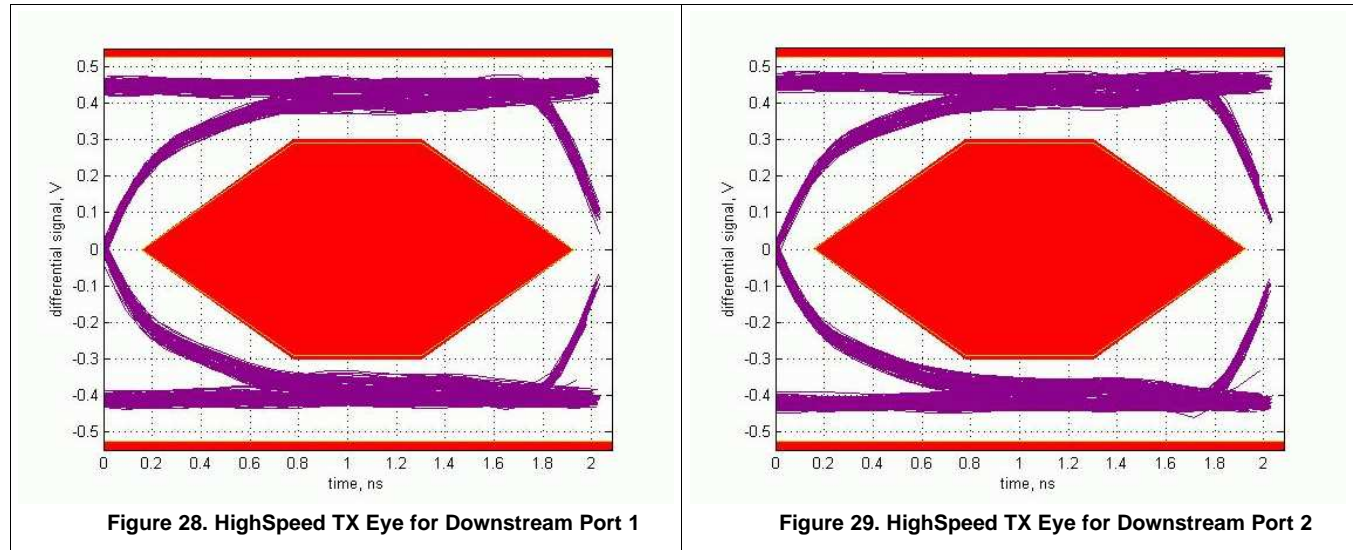

9.2.2 Downstream Port 1 Implementation

The downstream port 1 of the TUSB4020BI-Q1 is connected to a USB2 type A connector. With BATEN1 terminal pulled up, battery charge support is enabled for port 1. If battery charge support is not needed, then the pullup resistor on BATEN1 should be uninstalled. The PWRCTL_POL is pulled-down, which results in active-high power enable (PWRCTL1 and PWRCTL2) for a USB VBUS power switch.

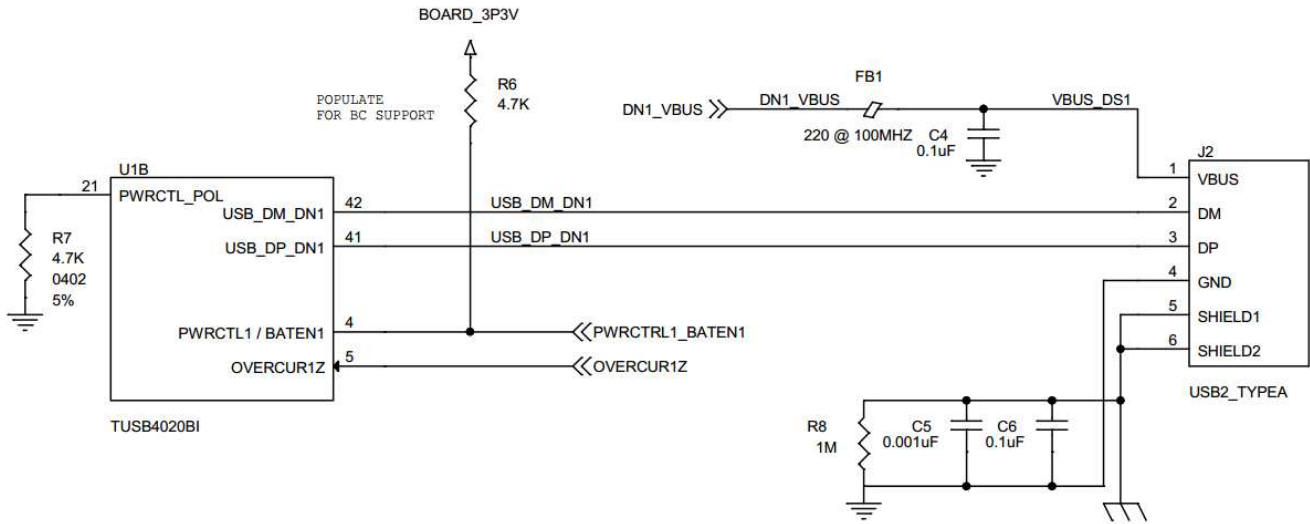

Figure 30. Downstream Port 1 Implementation Schematic

9.2.3 Downstream Port 2 Implementation

The downstream port 2 of the TUSB4020BI-Q1 is connected to a USB2 type A connector. With BATEN2 terminal pulled up, battery charge support is enabled for port 2. If battery charge support is not needed, then the pullup resistor on BATEN2 should be uninstalled.

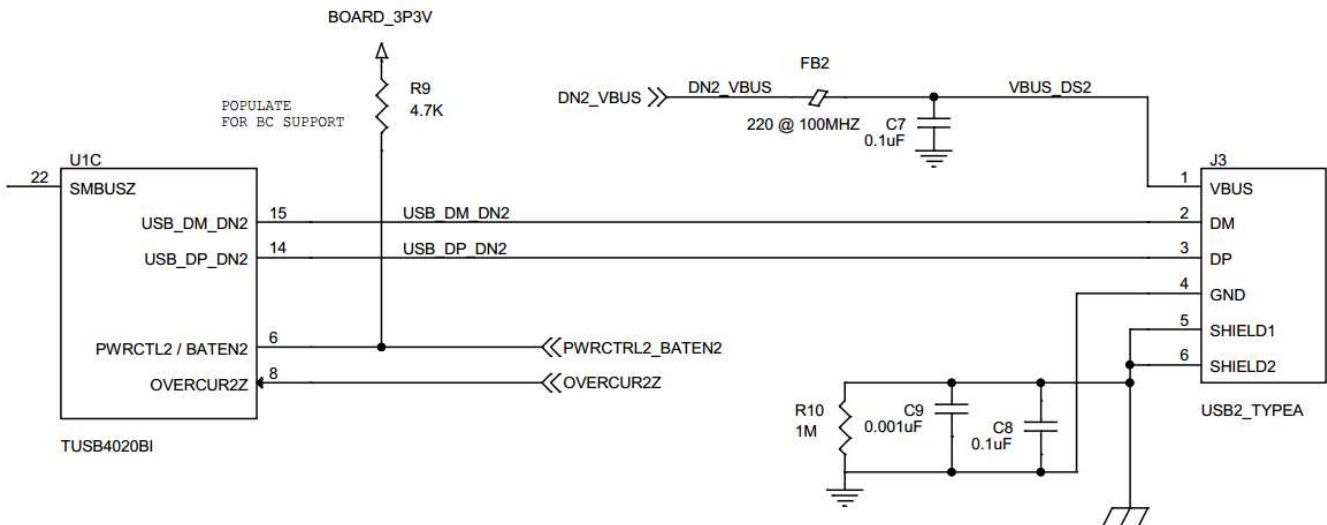

Figure 31. Downstream Port 2 Implementation Schematic

9.2.4 VBUS Power Switch Implementation

This particular example uses the TI [TPS2561](http://www.ti.com) dual-channel precision adjustable current-limited power switch. For details on this power switch or other power switches available from TI, refer to www.ti.com.

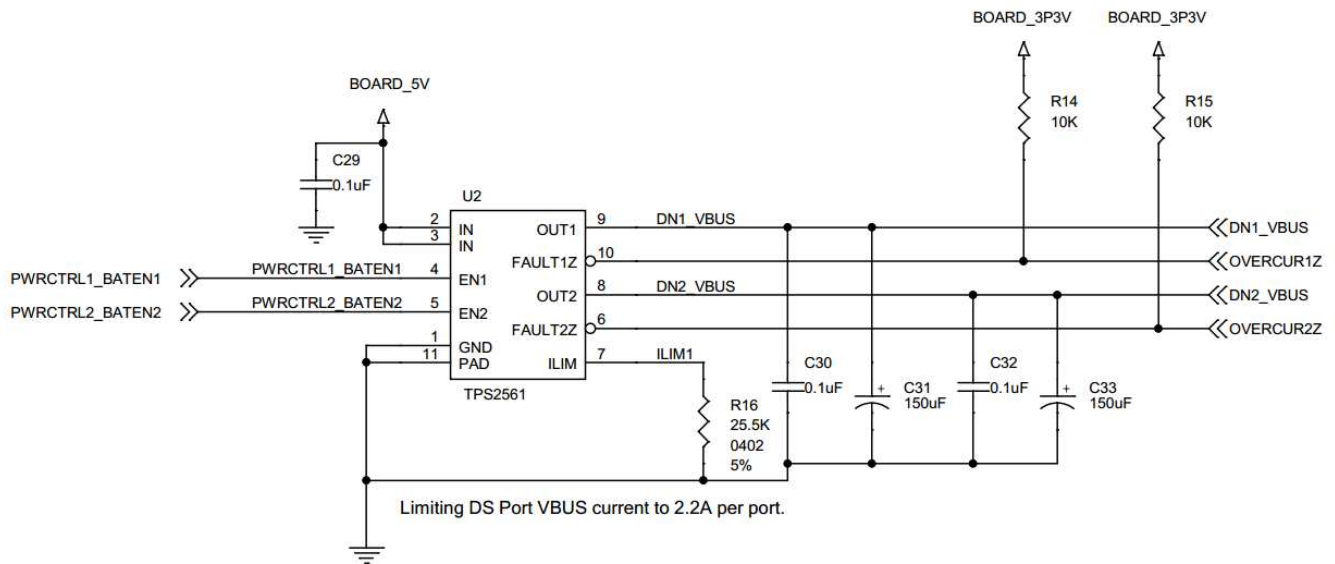

Figure 32. Power Switch Implementation Schematic

9.2.5 Clock, Reset, and Miscellaneous

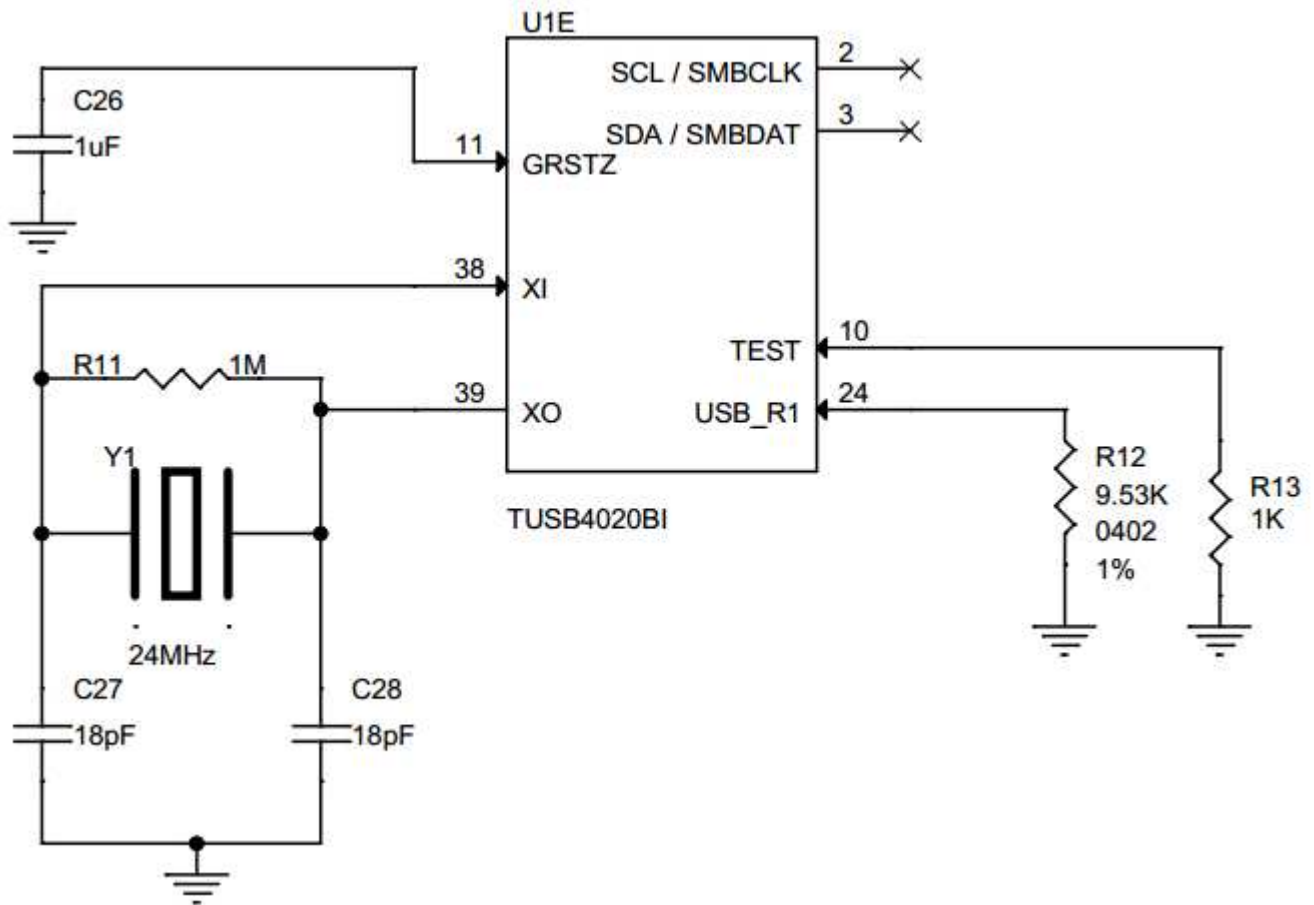

Figure 33. Clock, Reset, and Miscellaneous Schematic

9.2.6 Power Implementation

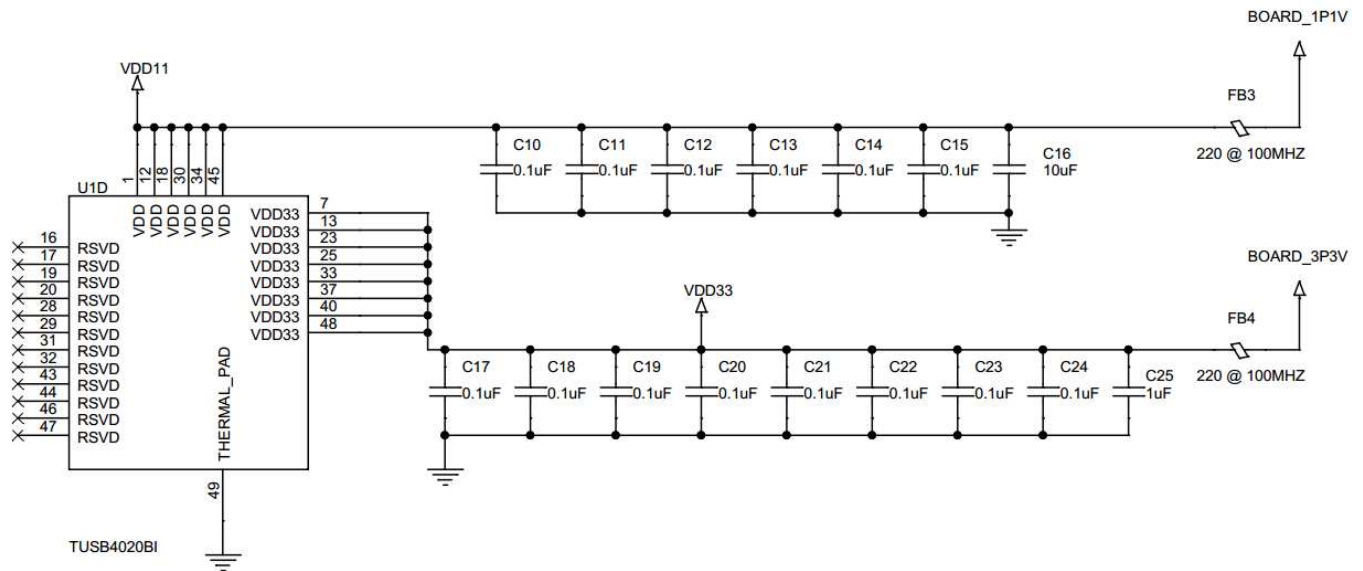

Figure 34. Power Implementation Schematic

10 Power Supply Recommendations

10.1 Power Supply

V_{DD} should be implemented as a single power plane, as should V_{DD33} .

- The V_{DD} terminals of the TUSB4020BI-Q1 supply 1.1-V (nominal) power to the core of the TUSB4020BI-Q1. This power rail can be isolated from all other power rails by a ferrite bead to reduce noise.
- The DC resistance of the ferrite bead on the core power rail can affect the voltage provided to the device due to the high current draw on the power rail. The output of the core voltage regulator may need to be adjusted to account for this or a ferrite bead with low DC resistance (less than 0.05 Ω) can be selected.
- The V_{DD33} terminals of the TUSB4020BI-Q1 supply 3.3-V power rail to the I/O of the TUSB4020BI-Q1. This power rail can be isolated from all other power rails by a ferrite bead to reduce noise.
- All power rails require a 10- μ F capacitor or 1- μ F capacitors for stability and noise immunity. These bulk capacitors can be placed anywhere on the power rail. The smaller decoupling capacitors should be placed as close to the TUSB4020BI-Q1 power pins as possible with an optimal grouping of two of differing values per pin.

10.2 Downstream Port Power

- The downstream port power, VBUS, must be supplied by a source capable of supplying 5 V and at least 500 mA per port. Downstream port power switches can be controlled by the TUSB4020BI-Q1 signals. It is possible to leave the downstream port power always enabled.
- Each downstream port's VBUS requires a large bulk low-ESR capacitor of 22 μ F or larger to limit in-rush current.
- TI recommends ferrite beads on the VBUS pins of the downstream USB port connections for both ESD and EMI reasons. A 0.1- μ F capacitor on the USB connector side of the ferrite provides a low-impedance path to ground for fast rise time ESD current that might have coupled onto the VBUS trace from the cable.

10.3 Ground

TI recommends to use only one board ground plane in the design. This provides the best image plane for signal traces running above the plane. The thermal pad of the TUSB4020BI-Q1 and any of the voltage regulators should be connected to this plane with vias. An earth or chassis ground is only implemented near the USB port connectors on a different plane for EMI and ESD purposes.

11 Layout

11.1 Layout Guidelines

11.1.1 Placement

1. A 9.53-k Ω \pm 1% resistor connected to terminal USB_R1 should be placed as close as possible to the TUSB4020BI-Q1.
2. A 0.1- μ F capacitor should be placed as close as possible on each V_{DD} and V_{DD33} power pin.
3. The ESD and EMI protection devices (if used) should also be placed as possible to the USB connector.
4. If a crystal is used, it must be placed as close as possible to the TUSB4020BI-Q1 device's XI and XO terminals.
5. Place voltage regulators as far away as possible from the TUSB4020BI-Q1, crystal, and differential pairs.
6. In general, the large bulk capacitors associated with each power rail should be placed as close as possible to the voltage regulators.

11.1.2 Package Specific

1. The TUSB4020BI-Q1 package has a 0.5-mm pin pitch.
2. The TUSB4020BI-Q1 package has a 3.6-mm \times 3.6-mm thermal pad. This thermal pad must be connected to ground through a system of vias.
3. All vias under device, except for those connected to thermal pad, should be solder masked to avoid potential issues with thermal pad layouts.

11.1.3 Differential Pairs

This section describes the layout recommendations for all of the TUSB4020BI-Q1 differential pairs: USB_DP_XX, USB_DM_XX.

- Must be designed with a differential impedance of 90 Ω \pm 10%.
- To minimize crosstalk, TI recommends to keep high-speed signals away from each other. Each pair should be separated by at least 5 \times the signal trace width. Separating with ground as depicted in the layout example also helps minimize crosstalk.
- Route all differential pairs on the same layer adjacent to a solid ground plane.
- Do not route differential pairs over any plane split.
- Adding test points causes impedance discontinuity, and therefore, negatively impacts signal performance. If test points are used, they should be placed in series and symmetrically. They must not be placed in a manner that causes stub on the differential pair.
- Avoid 90° turns in trace. The use of bends in differential traces should be kept to a minimum. When bends are used, the number of left and right bends should be as equal as possible and the angle of the bend should be \geq 135°. Taking this action minimizes any length mismatch caused by the bends, and therefore, minimizes the impact bends have on EMI.
- Minimize the trace lengths of the differential pair traces. Eight inches is the maximum recommended trace length for USB 2.0 differential-pair signals. Longer trace lengths require very careful routing to assure proper signal integrity.
- Match the etch lengths of the differential pair traces (that is DP and DM). The USB 2.0 differential pairs should not exceed 50-mils relative trace length difference.
- Minimize the use of vias in the differential-pair paths as much as possible. If this is not practical, ensure that the same via type and placement are used for both signals in a pair. Any vias used should be placed as close as possible to the TUSB4020BI-Q1 device.
- Do not place power fuses across the differential-pair traces.

11.2 Layout Example

Figure 35 shows an example layout of the upstream port to a USB3 Type B connector. The routing to a USB2 Type B connector will be similar.

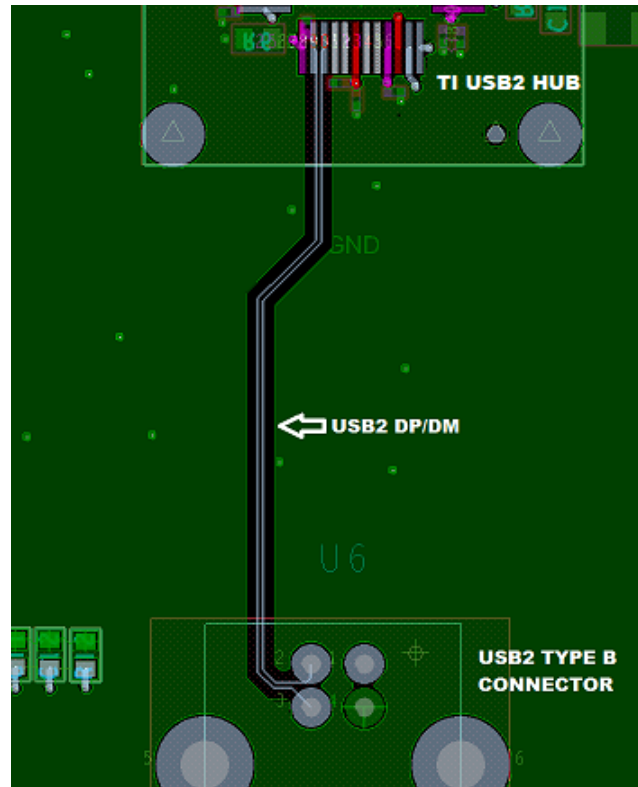

Figure 35. Upstream Port

Layout Example (continued)

Figure 36 shows an example layout of the Downstream Port to a USB3 Type A connector. The routing to a USB2 Type A connector will be similar.

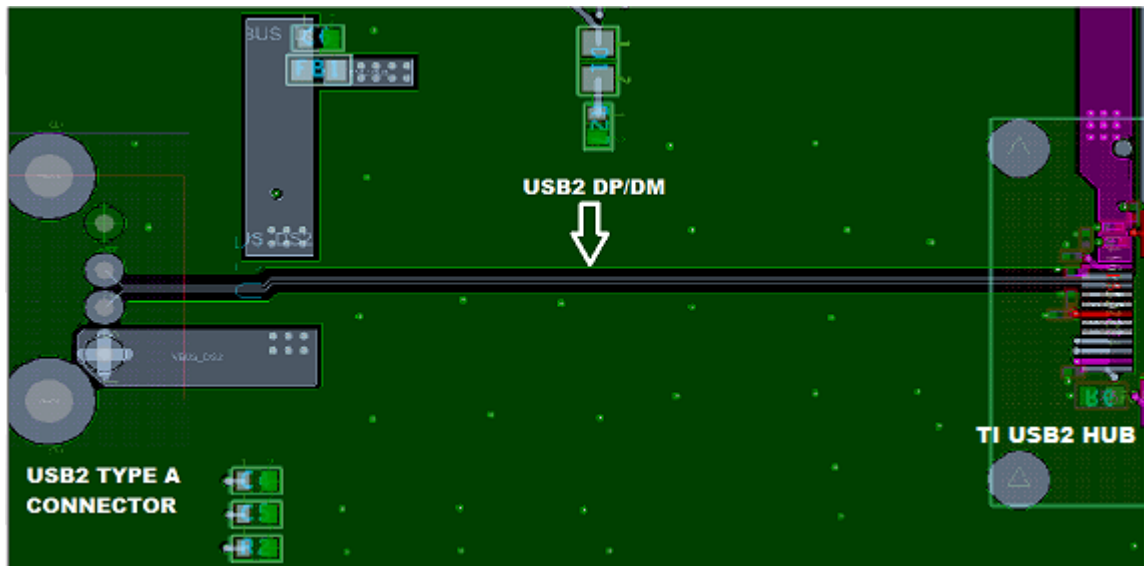

Figure 36. Downstream Port

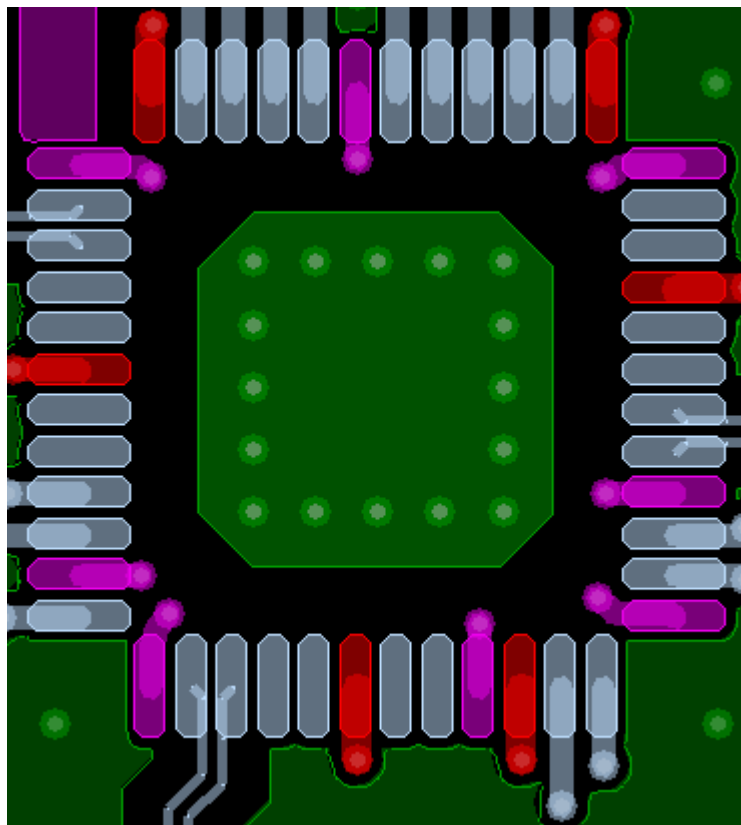

Figure 37. Thermal Pad

12 Device and Documentation Support

12.1 Community Resources

The following links connect to TI community resources. Linked contents are provided "AS IS" by the respective contributors. They do not constitute TI specifications and do not necessarily reflect TI's views; see TI's [Terms of Use](#).

TI E2E™ Online Community *TI's Engineer-to-Engineer (E2E) Community*. Created to foster collaboration among engineers. At e2e.ti.com, you can ask questions, share knowledge, explore ideas and help solve problems with fellow engineers.

Design Support *TI's Design Support* Quickly find helpful E2E forums along with design support tools and contact information for technical support.

12.2 Trademarks

E2E is a trademark of Texas Instruments.
All other trademarks are the property of their respective owners.

12.3 Electrostatic Discharge Caution



These devices have limited built-in ESD protection. The leads should be shorted together or the device placed in conductive foam during storage or handling to prevent electrostatic damage to the MOS gates.

12.4 Glossary

[SLYZ022](#) — *TI Glossary*.

This glossary lists and explains terms, acronyms, and definitions.

13 Mechanical, Packaging, and Orderable Information

The following pages include mechanical, packaging, and orderable information. This information is the most current data available for the designated devices. This data is subject to change without notice and revision of this document. For browser-based versions of this data sheet, refer to the left-hand navigation.

PACKAGING INFORMATION

Orderable Device	Status (1)	Package Type	Package Drawing	Pins	Package Qty	Eco Plan (2)	Lead/Ball Finish (6)	MSL Peak Temp (3)	Op Temp (°C)	Device Marking (4/5)	Samples
TUSB4020BIPHPQ1	ACTIVE	HTQFP	PHP	48	250	Green (RoHS & no Sb/Br)	CU NIPDAU	Level-3-260C-168 HR	-40 to 85	T4020BIQ1	Samples
TUSB4020BIPHRQ1	ACTIVE	HTQFP	PHP	48	1000	Green (RoHS & no Sb/Br)	CU NIPDAU	Level-3-260C-168 HR	-40 to 85	T4020BIQ1	Samples

(1) The marketing status values are defined as follows:

ACTIVE: Product device recommended for new designs.

LIFEBUY: TI has announced that the device will be discontinued, and a lifetime-buy period is in effect.

NRND: Not recommended for new designs. Device is in production to support existing customers, but TI does not recommend using this part in a new design.

PREVIEW: Device has been announced but is not in production. Samples may or may not be available.

OBSOLETE: TI has discontinued the production of the device.

(2) Eco Plan - The planned eco-friendly classification: Pb-Free (RoHS), Pb-Free (RoHS Exempt), or Green (RoHS & no Sb/Br) - please check <http://www.ti.com/productcontent> for the latest availability information and additional product content details.

TBD: The Pb-Free/Green conversion plan has not been defined.

Pb-Free (RoHS): TI's terms "Lead-Free" or "Pb-Free" mean semiconductor products that are compatible with the current RoHS requirements for all 6 substances, including the requirement that lead not exceed 0.1% by weight in homogeneous materials. Where designed to be soldered at high temperatures, TI Pb-Free products are suitable for use in specified lead-free processes.

Pb-Free (RoHS Exempt): This component has a RoHS exemption for either 1) lead-based flip-chip solder bumps used between the die and package, or 2) lead-based die adhesive used between the die and leadframe. The component is otherwise considered Pb-Free (RoHS compatible) as defined above.

Green (RoHS & no Sb/Br): TI defines "Green" to mean Pb-Free (RoHS compatible), and free of Bromine (Br) and Antimony (Sb) based flame retardants (Br or Sb do not exceed 0.1% by weight in homogeneous material)

(3) MSL, Peak Temp. - The Moisture Sensitivity Level rating according to the JEDEC industry standard classifications, and peak solder temperature.

(4) There may be additional marking, which relates to the logo, the lot trace code information, or the environmental category on the device.

(5) Multiple Device Markings will be inside parentheses. Only one Device Marking contained in parentheses and separated by a "~" will appear on a device. If a line is indented then it is a continuation of the previous line and the two combined represent the entire Device Marking for that device.

(6) Lead/Ball Finish - Orderable Devices may have multiple material finish options. Finish options are separated by a vertical ruled line. Lead/Ball Finish values may wrap to two lines if the finish value exceeds the maximum column width.

Important Information and Disclaimer: The information provided on this page represents TI's knowledge and belief as of the date that it is provided. TI bases its knowledge and belief on information provided by third parties, and makes no representation or warranty as to the accuracy of such information. Efforts are underway to better integrate information from third parties. TI has taken and continues to take reasonable steps to provide representative and accurate information but may not have conducted destructive testing or chemical analysis on incoming materials and chemicals. TI and TI suppliers consider certain information to be proprietary, and thus CAS numbers and other limited information may not be available for release.

In no event shall TI's liability arising out of such information exceed the total purchase price of the TI part(s) at issue in this document sold by TI to Customer on an annual basis.

OTHER QUALIFIED VERSIONS OF TUSB4020BI-Q1 :

- Catalog: [TUSB4020BI](#)

NOTE: Qualified Version Definitions:

- Catalog - TI's standard catalog product

TAPE AND REEL INFORMATION

QUADRANT ASSIGNMENTS FOR PIN 1 ORIENTATION IN TAPE

*All dimensions are nominal

Device	Package Type	Package Drawing	Pins	SPQ	Reel Diameter (mm)	Reel Width W1 (mm)	A0 (mm)	B0 (mm)	K0 (mm)	P1 (mm)	W (mm)	Pin1 Quadrant
TUSB4020BIPHRQ1	HTQFP	PHP	48	1000	330.0	16.4	9.6	9.6	1.5	12.0	16.0	Q2

TAPE AND REEL BOX DIMENSIONS



*All dimensions are nominal

Device	Package Type	Package Drawing	Pins	SPQ	Length (mm)	Width (mm)	Height (mm)
TUSB4020BIPHRQ1	HTQFP	PHP	48	1000	336.6	336.6	31.8

PHP (S-PQFP-G48)

PowerPAD™ PLASTIC QUAD FLATPACK

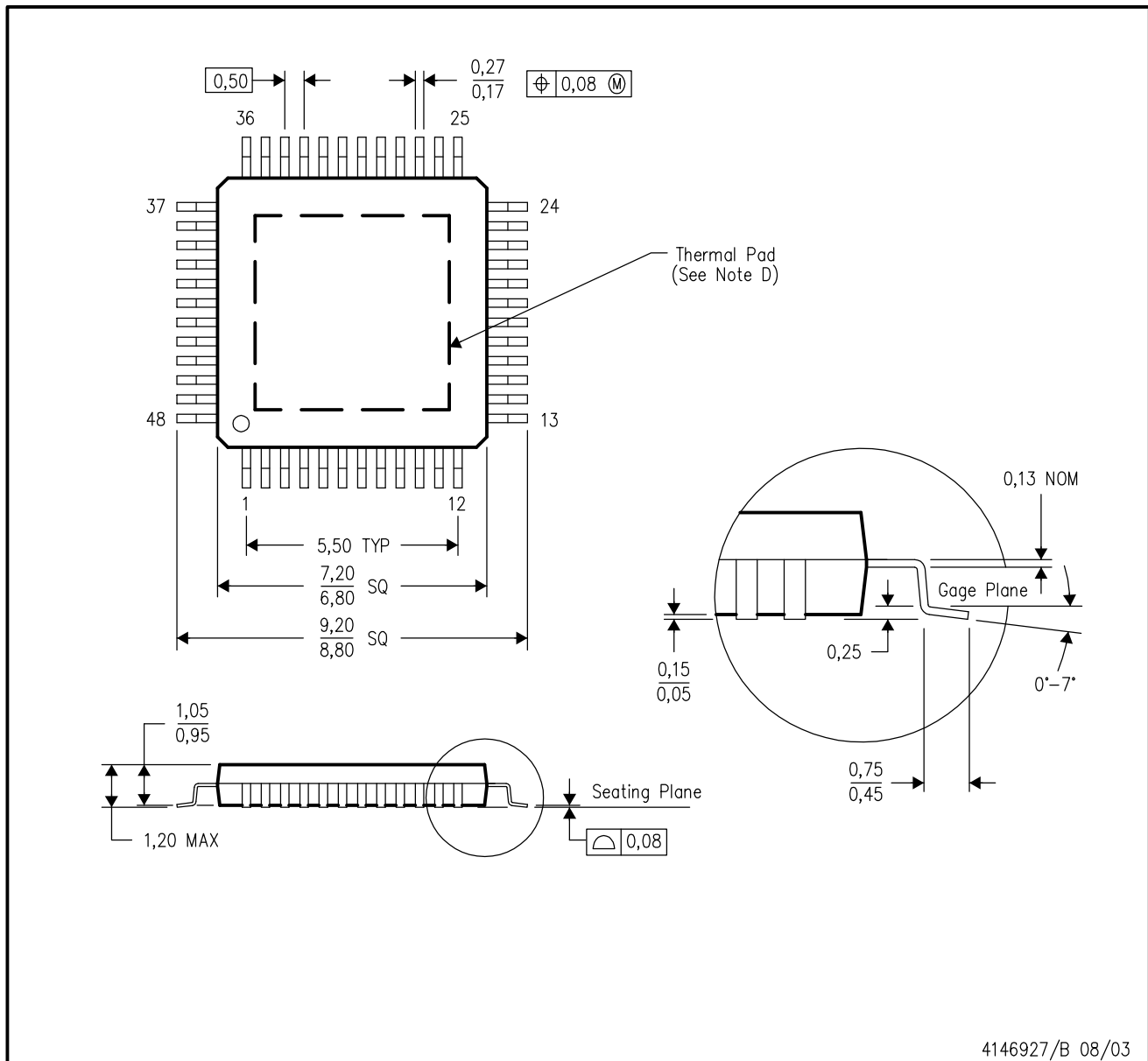

- NOTES:
- All linear dimensions are in millimeters.
 - This drawing is subject to change without notice.
 - Body dimensions do not include mold flash or protrusion.
 - This package is designed to be soldered to a thermal pad on the board. Refer to Technical Brief, PowerPad Thermally Enhanced Package, Texas Instruments Literature No. SLMA002 for information regarding recommended board layout. This document is available at www.ti.com <<http://www.ti.com>>.
 - Falls within JEDEC MS-026

PowerPAD is a trademark of Texas Instruments.

THERMAL PAD MECHANICAL DATA

PHP (S-PQFP-G48)

PowerPAD™ PLASTIC QUAD FLATPACK

THERMAL INFORMATION

This PowerPAD™ package incorporates an exposed thermal pad that is designed to be attached to a printed circuit board (PCB). The thermal pad must be soldered directly to the PCB. After soldering, the PCB can be used as a heatsink. In addition, through the use of thermal vias, the thermal pad can be attached directly to the appropriate copper plane shown in the electrical schematic for the device, or alternatively, can be attached to a special heatsink structure designed into the PCB. This design optimizes the heat transfer from the integrated circuit (IC).

For additional information on the PowerPAD package and how to take advantage of its heat dissipating abilities, refer to Technical Brief, PowerPAD Thermally Enhanced Package, Texas Instruments Literature No. SLMA002 and Application Brief, PowerPAD Made Easy, Texas Instruments Literature No. SLMA004. Both documents are available at www.ti.com.

The exposed thermal pad dimensions for this package are shown in the following illustration.

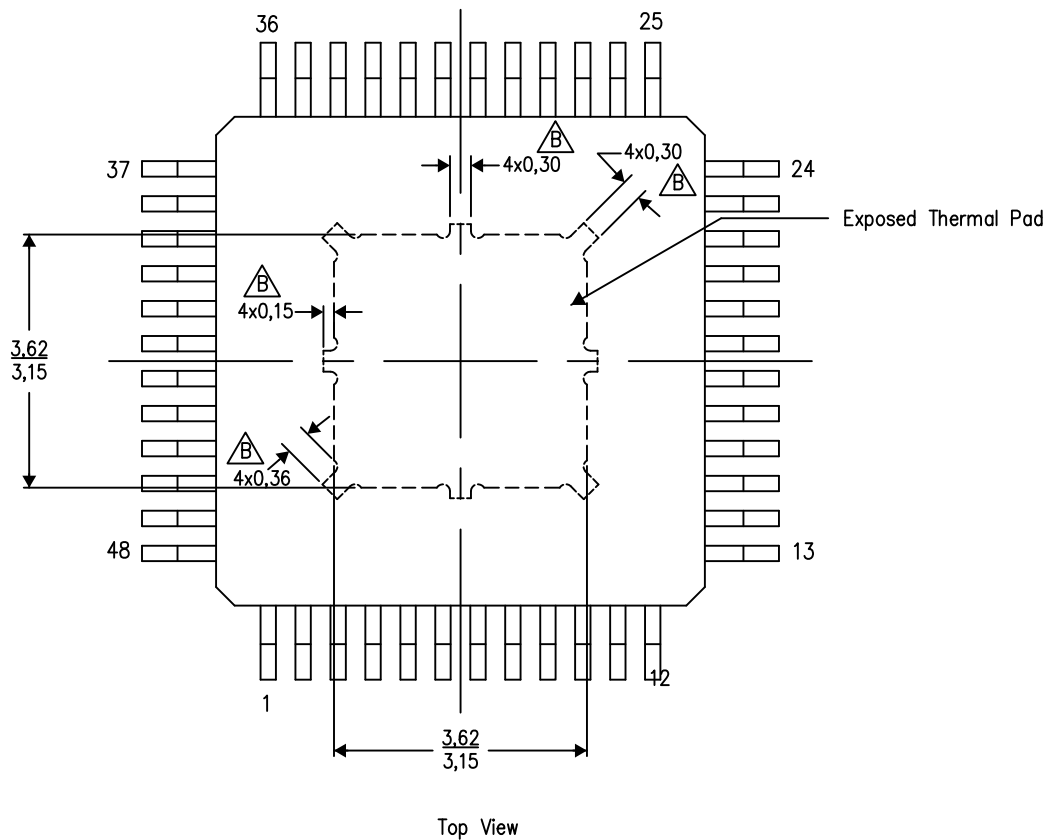

Exposed Thermal Pad Dimensions

4206329-13/P 03/15

NOTE: A. All linear dimensions are in millimeters

 Tie strap features may not be present.

PowerPAD is a trademark of Texas Instruments

PHP (S-PQFP-G48)

PowerPAD™ PLASTIC QUAD FLATPACK

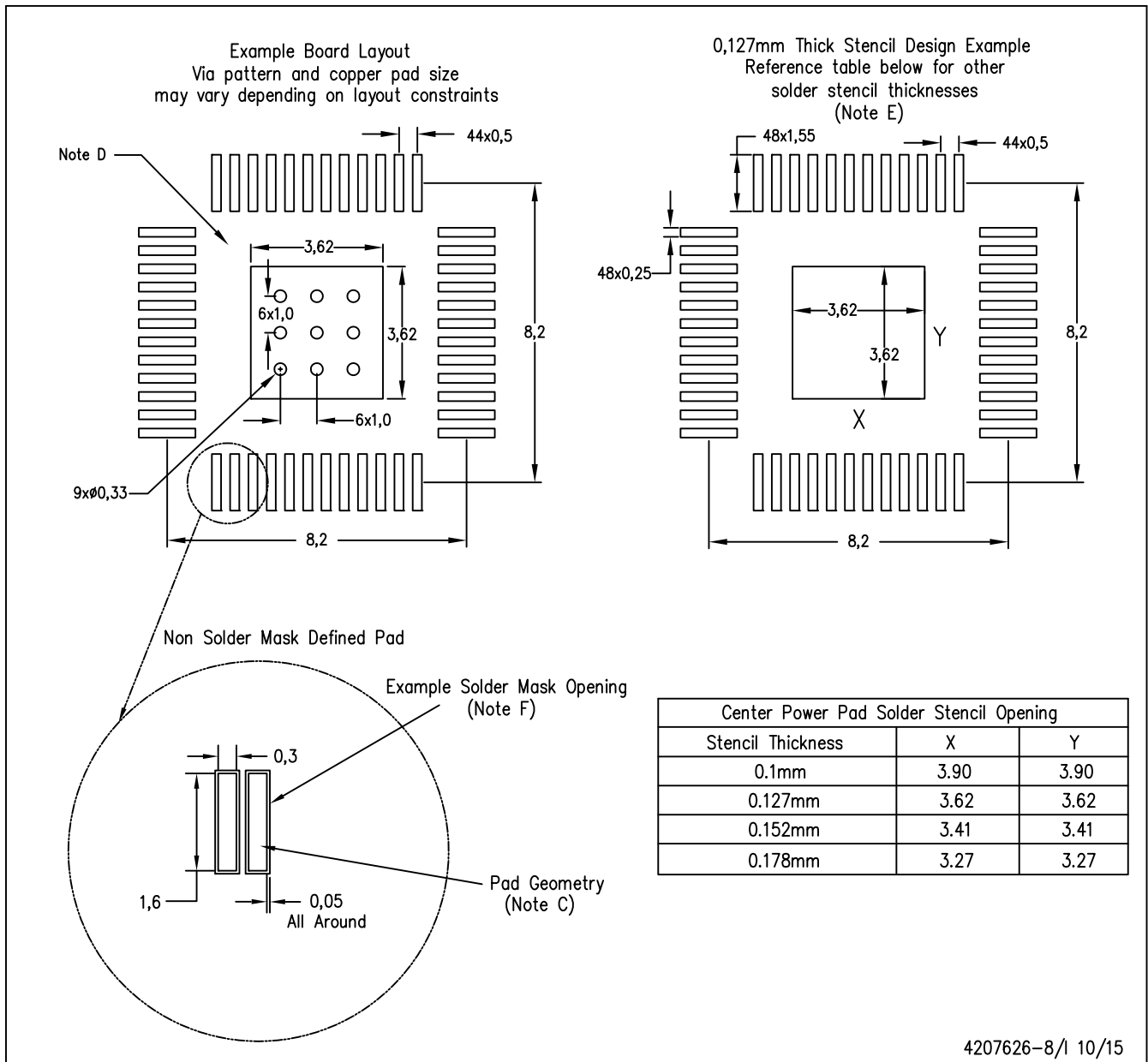

- NOTES:
- A. All linear dimensions are in millimeters.
 - B. This drawing is subject to change without notice.
 - C. Publication IPC-7351 is recommended for alternate designs.
 - D. This package is designed to be soldered to a thermal pad on the board. Refer to Technical Brief, PowerPAD Thermally Enhanced Package, Texas Instruments Literature No. SLMA002, SLMA004, and also the Product Data Sheets for specific thermal information, via requirements, and recommended board layout. These documents are available at www.ti.com <<http://www.ti.com>>.
 - E. Laser cutting apertures with trapezoidal walls and also rounding corners will offer better paste release. Customers should contact their board assembly site for stencil design recommendations. Refer to IPC 7525 for stencil design considerations.
 - F. Customers should contact their board fabrication site for recommended solder mask tolerances and via tenting options for vias placed in the thermal pad.

PowerPAD is a trademark of Texas Instruments

IMPORTANT NOTICE

Texas Instruments Incorporated and its subsidiaries (TI) reserve the right to make corrections, enhancements, improvements and other changes to its semiconductor products and services per JESD46, latest issue, and to discontinue any product or service per JESD48, latest issue. Buyers should obtain the latest relevant information before placing orders and should verify that such information is current and complete. All semiconductor products (also referred to herein as "components") are sold subject to TI's terms and conditions of sale supplied at the time of order acknowledgment.

TI warrants performance of its components to the specifications applicable at the time of sale, in accordance with the warranty in TI's terms and conditions of sale of semiconductor products. Testing and other quality control techniques are used to the extent TI deems necessary to support this warranty. Except where mandated by applicable law, testing of all parameters of each component is not necessarily performed.

TI assumes no liability for applications assistance or the design of Buyers' products. Buyers are responsible for their products and applications using TI components. To minimize the risks associated with Buyers' products and applications, Buyers should provide adequate design and operating safeguards.

TI does not warrant or represent that any license, either express or implied, is granted under any patent right, copyright, mask work right, or other intellectual property right relating to any combination, machine, or process in which TI components or services are used. Information published by TI regarding third-party products or services does not constitute a license to use such products or services or a warranty or endorsement thereof. Use of such information may require a license from a third party under the patents or other intellectual property of the third party, or a license from TI under the patents or other intellectual property of TI.

Reproduction of significant portions of TI information in TI data books or data sheets is permissible only if reproduction is without alteration and is accompanied by all associated warranties, conditions, limitations, and notices. TI is not responsible or liable for such altered documentation. Information of third parties may be subject to additional restrictions.

Resale of TI components or services with statements different from or beyond the parameters stated by TI for that component or service voids all express and any implied warranties for the associated TI component or service and is an unfair and deceptive business practice. TI is not responsible or liable for any such statements.

Buyer acknowledges and agrees that it is solely responsible for compliance with all legal, regulatory and safety-related requirements concerning its products, and any use of TI components in its applications, notwithstanding any applications-related information or support that may be provided by TI. Buyer represents and agrees that it has all the necessary expertise to create and implement safeguards which anticipate dangerous consequences of failures, monitor failures and their consequences, lessen the likelihood of failures that might cause harm and take appropriate remedial actions. Buyer will fully indemnify TI and its representatives against any damages arising out of the use of any TI components in safety-critical applications.

In some cases, TI components may be promoted specifically to facilitate safety-related applications. With such components, TI's goal is to help enable customers to design and create their own end-product solutions that meet applicable functional safety standards and requirements. Nonetheless, such components are subject to these terms.

No TI components are authorized for use in FDA Class III (or similar life-critical medical equipment) unless authorized officers of the parties have executed a special agreement specifically governing such use.

Only those TI components which TI has specifically designated as military grade or "enhanced plastic" are designed and intended for use in military/aerospace applications or environments. Buyer acknowledges and agrees that any military or aerospace use of TI components which have **not** been so designated is solely at the Buyer's risk, and that Buyer is solely responsible for compliance with all legal and regulatory requirements in connection with such use.

TI has specifically designated certain components as meeting ISO/TS16949 requirements, mainly for automotive use. In any case of use of non-designated products, TI will not be responsible for any failure to meet ISO/TS16949.

Products

Audio	www.ti.com/audio
Amplifiers	amplifier.ti.com
Data Converters	dataconverter.ti.com
DLP® Products	www.dlp.com
DSP	dsp.ti.com
Clocks and Timers	www.ti.com/clocks
Interface	interface.ti.com
Logic	logic.ti.com
Power Mgmt	power.ti.com
Microcontrollers	microcontroller.ti.com
RFID	www.ti-rfid.com
OMAP Applications Processors	www.ti.com/omap
Wireless Connectivity	www.ti.com/wirelessconnectivity

Applications

Automotive and Transportation	www.ti.com/automotive
Communications and Telecom	www.ti.com/communications
Computers and Peripherals	www.ti.com/computers
Consumer Electronics	www.ti.com/consumer-apps
Energy and Lighting	www.ti.com/energy
Industrial	www.ti.com/industrial
Medical	www.ti.com/medical
Security	www.ti.com/security
Space, Avionics and Defense	www.ti.com/space-avionics-defense
Video and Imaging	www.ti.com/video

TI E2E Community

e2e.ti.com