

High-voltage, high-side current sense amplifier

Features

- Independent supply and input common-mode voltages
- Wide common-mode operating range:
2.9 to 70 V in single-supply configuration
-2.1 to 65 V in dual-supply configuration
- Wide common-mode surviving range:
-16 to 75 V (reversed battery and load-dump conditions)
- Supply voltage range:
2.7 to 5.5 V in single supply configuration
- Low current consumption: I_{CC} max = 360 μ A
- Pin selectable gain: 50 V/V or 100 V/V
- Buffered output
- EMI filtering

Applications

- Automotive current monitoring
- DC motor control
- Photovoltaic systems
- Battery chargers
- Precision current sources
- Current monitoring of notebook computers
- Uninterruptible power supplies
- High-end power supplies

Description

The TSC1031 measures a small differential voltage on a high-side shunt resistor and translates it into a ground-referenced output voltage. The TSC1031's dedicated schematic eases the implementation of EMI filtering in harsh environments. The gain is adjustable to 50 V/V or 100 V/V by a selection pin.

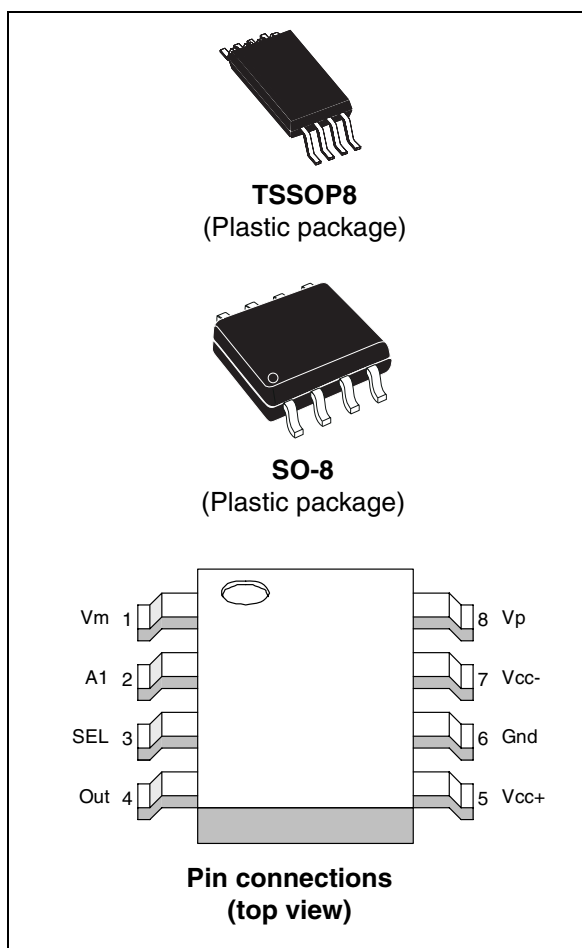

Wide input common-mode voltage range, low quiescent current, and tiny TSSOP8 packaging enable use in a wide variety of applications.

The input common-mode and power supply voltages are independent. The common-mode voltage can range from 2.9 to 70 V in the single-supply configuration or be offset by an adjustable voltage supplied on the Vcc- pin in the dual-supply configuration.

With a current consumption lower than 360 μ A and a virtually null input leakage current in standby mode, the power consumption in the applications is minimized.

Contents

- 1 Application schematic and pin description 3**
- 2 Absolute maximum ratings and operating conditions 6**
- 3 Electrical characteristics 7**
- 4 Electrical characteristics curves: current sense amplifier 10**
- 5 Parameter definitions 13**
 - 5.1 Common mode rejection ratio (CMR) 13
 - 5.2 Supply voltage rejection ratio (SVR) 13
 - 5.3 Gain (A_v) and input offset voltage (V_{os}) 13
 - 5.4 Output voltage drift versus temperature 15
 - 5.5 Input offset drift versus temperature 16
 - 5.6 Output voltage accuracy 16
- 6 Maximum permissible voltages on pins 18**
- 7 Application information 19**
- 8 Package information 21**
 - 8.1 SO-8 package information 22
 - 8.2 TSSOP-8 package information 23
- 9 Ordering information 24**
- 10 Revision history 25**

1 Application schematic and pin description

The TSC1031 high-side current sense amplifier can be used in either single- or dual-supply mode. In the single-supply configuration, the TSC1031 features a wide 2.9 V to 70 V input common-mode range totally independent of the supply voltage. In the dual-supply range, the common-mode range is shifted by the value of the negative voltage applied on the Vcc- pin. For instance, with Vcc+ = 5 V and Vcc- = -5 V, then the input common-mode range is -2.1 V to 65 V.

Figure 1. Single-supply configuration schematic

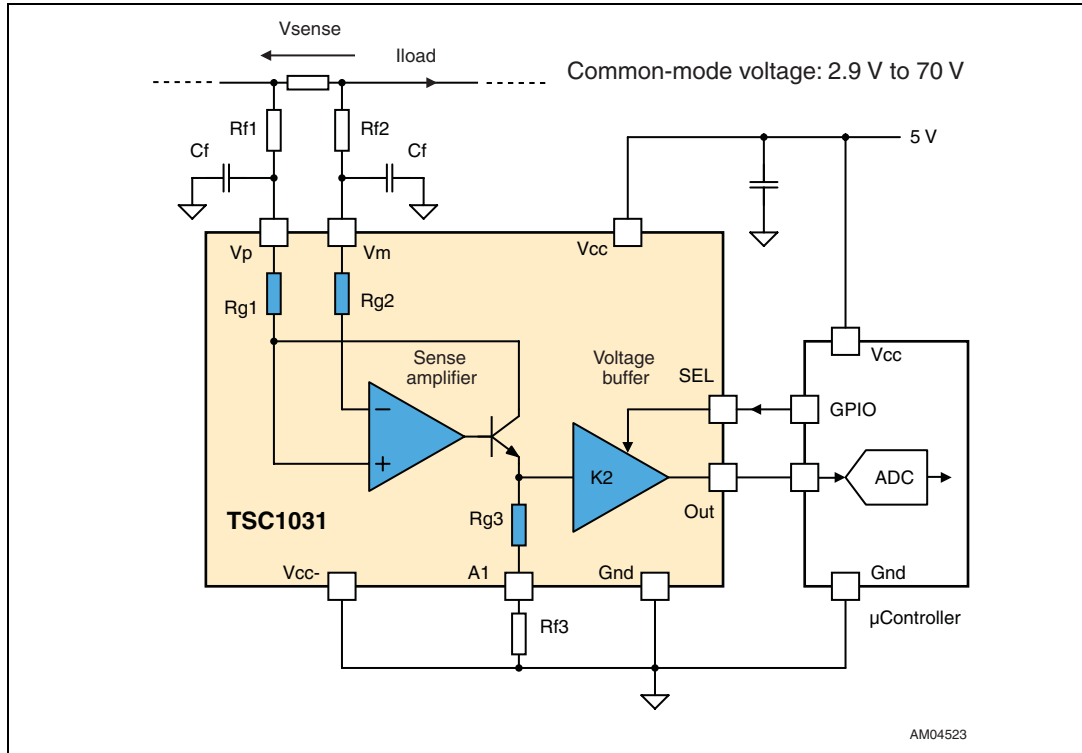

Figure 2. Dual-supply configuration schematic

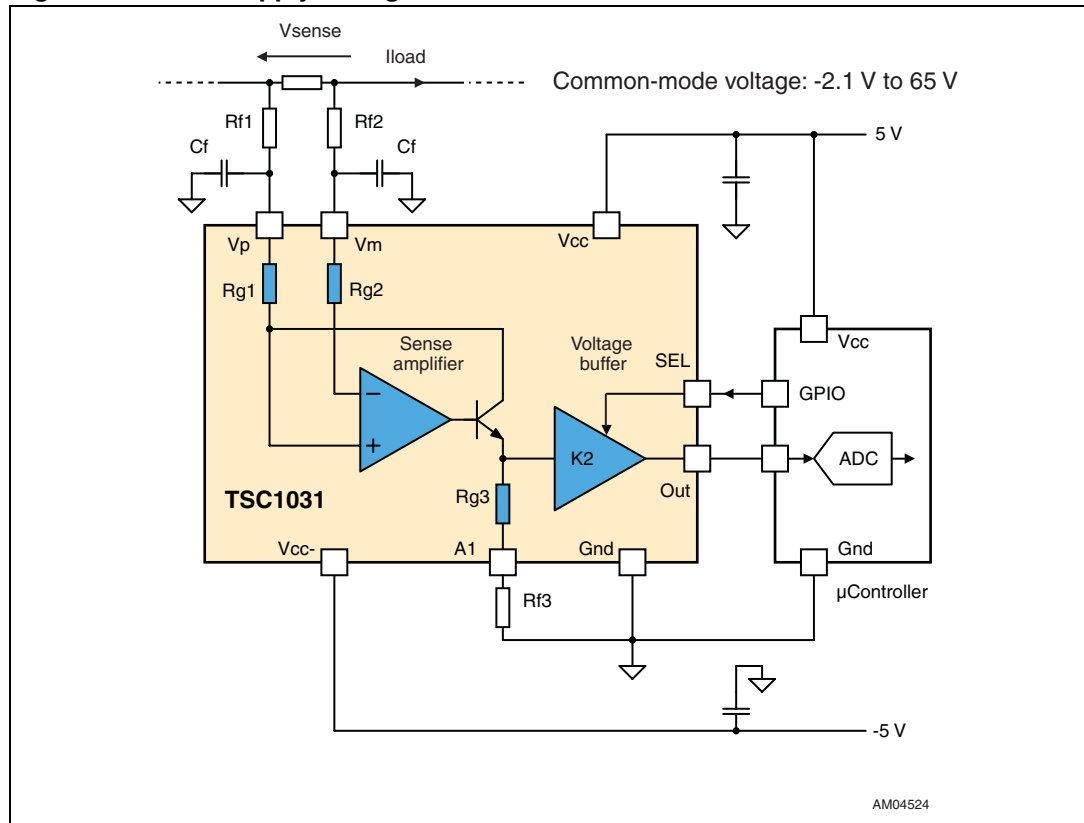

Figure 3. Common-mode versus supply voltage in dual-supply configuration

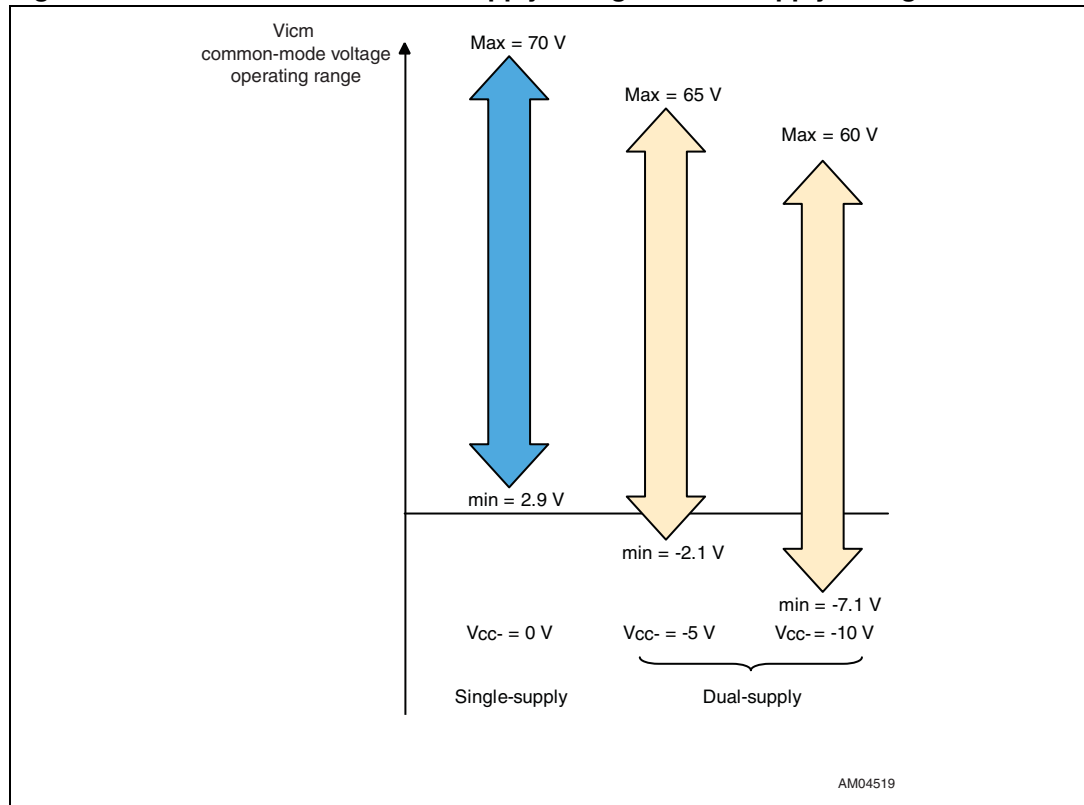

Table 1 describes the function of each pin. Their position is shown in the illustration on the cover page and in Figure 1 on page 3.

Table 1. Pin description

Symbol	Type	Function
Out	Analog output	The Out voltage is proportional to the magnitude of the sense voltage $V_p - V_m$.
Gnd	Power supply	Ground line.
Vcc+	Power supply	Positive power supply line.
Vcc-	Power supply	Negative power supply line.
Vp	Analog input	Connection for the external sense resistor. The measured current enters the shunt on the V_p side.
Vm	Analog input	Connection for the external sense resistor. The measured current exits the shunt on the V_m side.
SEL	Digital input	Gain-select pin.
A1	Analog output	Connection to the output resistor.

2 Absolute maximum ratings and operating conditions

Table 2. Absolute maximum ratings

Symbol	Parameter	Value	Unit
V_{id}	Input pins differential voltage ($V_p - V_m$)	± 20	V
V_{in_sense}	Sensing pins input voltages (V_p, V_m) ⁽¹⁾	-16 to 75	V
V_{in_sel}	Gain selection pin input voltage (SEL) ⁽²⁾	-0.3 to $V_{CC+} + 0.3$	V
V_{in_A1}	A1 pin input voltage ⁽²⁾	-0.3 to $V_{CC+} + 0.3$	V
V_{CC+}	Positive supply voltage ⁽²⁾	-0.3 to 7	V
$V_{CC+} - V_{CC-}$	DC supply voltage	0 to 15	V
V_{out}	DC output pin voltage ⁽²⁾	-0.3 to $V_{CC+} + 0.3$	V
T_{stg}	Storage temperature	-55 to 150	°C
T_j	Maximum junction temperature	150	°C
R_{thja}	TSSOP8 thermal resistance junction to ambient	120	°C/W
	SO-8 thermal resistance junction to ambient	125	°C/W
ESD	HBM: human body model ⁽³⁾	2.5	kV
	MM: machine model ⁽⁴⁾	150	V
	CDM: charged device model ⁽⁵⁾	1.5	kV

1. These voltage values are measured with respect to the V_{CC-} pin.
2. These voltage values are measured with respect to the Gnd pin.
3. Human body model: a 100 pF capacitor is charged to the specified voltage, then discharged through a 1.5 kΩ resistor between two pins of the device. This is done for all couples of connected pin combinations while the other pins are floating.
4. Machine model: a 200 pF capacitor is charged to the specified voltage, then discharged directly between two pins of the device with no external series resistor (internal resistor < 5 Ω). This is done for all couples of connected pin combinations while the other pins are floating.
5. Charged device model: all pins plus package are charged together to the specified voltage and then discharged directly to ground.

Table 3. Operating conditions

Symbol	Parameter	Value	Unit
V_{CC+}	DC supply voltage in single-supply configuration from T_{min} to T_{max} (V_{CC-} connected to Gnd = 0 V)	2.7 to 5.5	V
V_{CC-}	Negative supply voltage in dual-supply configuration from T_{min} to T_{max}		
	$V_{CC+} = 5.5$ V max	-8 to 0	V
	$V_{CC+} = 3$ V max	-11 to 0	V
V_{icm}	Common-mode voltage range referred to pin Vcc - (T_{min} to T_{max})	2.9 to 70	V
T_{oper}	Operational temperature range (T_{min} to T_{max})	-40 to 125	°C

3 Electrical characteristics

The electrical characteristics given in the following tables are measured under the following test conditions unless otherwise specified.

- $T_{amb} = 25^{\circ}C$, $V_{CC+} = 5V$, V_{CC-} connected to Gnd (single-supply configuration).
- $V_{sense} = V_p - V_m = 50mV$, $V_m = 12V$, no load on Out, all gain configurations.
- Rf1, Rf2 and Rf3 resistors are short-circuited.

Table 4. Supply

Symbol	Parameter	Test conditions	Min.	Typ.	Max.	Unit
I_{CC}	Total supply current	$V_{sense} = 0V$, $T_{min} < T_{amb} < T_{max}$		200	360	μA
I_{CC1}	Total supply current	$V_{sense} = 50mV$ $A_v = 50V/V$ $T_{min} < T_{amb} < T_{max}$		300	480	μA

Table 5. Input

Symbol	Parameter	Test conditions	Min.	Typ.	Max.	Unit
DC CMR	DC common-mode rejection Variation of V_{out} versus V_{icm} referred to input ⁽¹⁾	$2.9V < V_m < 70V$, $T_{min} < T_{amb} < T_{max}$	90	105		dB
AC CMR	AC common-mode rejection Variation of V_{out} versus V_{icm} referred to input (peak-to-peak voltage variation)	$A_v = 50V/V$ or $100V/V$ $2.9V < V_{icm} < 30V$, 1 kHz sine wave		95		dB
SVR	Supply voltage rejection Variation of V_{out} versus V_{CC} ⁽²⁾	$A_v = 50V/V$, $2.7V < V_{CC} < 5.5V$ $V_{sense} = 30mV$, $T_{min} < T_{amb} < T_{max}$	85	100		dB
V_{os}	Input offset voltage ⁽³⁾	$T_{amb} = 25^{\circ}C$ $T_{min} < T_{amb} < T_{max}$			± 500 ± 1100	μV
dV_{os}/dT	Input offset drift vs. T	$A_v = 50V/V$ $T_{min} < T_{amb} < T_{max}$	-20		+5	$\mu V/^{\circ}C$
I_{lk}	Input leakage current	$V_{CC} = 0V$ $T_{min} < T_{amb} < T_{max}$			1	μA
I_{ib}	Input bias current	$V_{sense} = 0V$ $T_{min} < T_{amb} < T_{max}$		10	15	μA
Rg	Input resistor value	Valid for Rg1 and Rg2		5		k Ω
V_{IL}	Logic low voltage (SEL)	$V_{CCmin} < V_{CC} < V_{CCmax}$ $T_{min} < T_{amb} < T_{max}$	-0.3		0.5	V
V_{IH}	Logic high voltage (SEL)	$V_{CCmin} < V_{CC} < V_{CCmax}$ $T_{min} < T_{amb} < T_{max}$	1.2		V_{CC}	V
I_{sel}	Gain-select pins (SEL) leakage input current	SEL pin connected to GND or V_{CC} $T_{min} < T_{amb} < T_{max}$		400		nA

1. See [Chapter 5: Parameter definitions on page 13](#) for the definition of CMR.

2. See [Chapter 5](#) for the definition of SVR.

3. See [Chapter 5](#) for the definition of V_{os} .

Table 6. Output

Symbol	Parameter	Test conditions	Min.	Typ.	Max.	Unit
K1	Sense amplifier gain ($K1 = Rg3/Rg1$)			10		
K2	Current multiplier gain	SEL= Gnd SEL= Vcc+		2.5 5		
Av	Total gain ($Av = 2.K1.K2$)	SEL= Gnd SEL= Vcc+		50 100		V/V
$\Delta V_{out}/\Delta T$	Output voltage drift vs. T ⁽¹⁾	Av = 50 V/V $T_{min} < T_{amb} < T_{max}$			±240	ppm/°C
$\Delta V_{out}/\Delta I_{out}$	Output stage load regulation	-10 mA < I _{out} < 10 mA I _{out} sink or source current Av = 50 V/V, T _{amb} = 25° C		0.3	±1.5	mV/mA
ΔV_{out}	Total output voltage accuracy ⁽²⁾	V _{sense} = 50 mV ⁽³⁾ T _{amb} = 25° C $T_{min} < T_{amb} < T_{max}$			±2.5 ±4	%
ΔV_{out}	Total output voltage accuracy	V _{sense} = 90 mV ⁽³⁾ T _{amb} = 25° C $T_{min} < T_{amb} < T_{max}$			±3.5 ±5	%
ΔV_{out}	Total output voltage accuracy	V _{sense} = 20 mV T _{amb} = 25° C $T_{min} < T_{amb} < T_{max}$			±3.5 ±5	%
ΔV_{out}	Total output voltage accuracy	V _{sense} = 10 mV T _{amb} = 25° C $T_{min} < T_{amb} < T_{max}$			±5.5 ±8	%
ΔV_{out}	Total output voltage accuracy	V _{sense} = 5 mV T _{amb} = 25° C $T_{min} < T_{amb} < T_{max}$			±10 ±22	%
I _{sc}	Short-circuit current	OUT connected to V _{CC} or GND	15	26		mA
V _{OH}	Output stage high-state saturation voltage V _{OH} = V _{CC} -V _{out}	V _{sense} = 1 V I _{out} = 1 mA		85	135	mV
V _{OL}	Output stage low-state saturation voltage	V _{sense} = -1 V I _{out} = 1 mA		80	125	mV

1. See [Chapter 5: Parameter definitions on page 13](#) for the definition of output voltage drift versus temperature.
2. The output voltage accuracy is the difference with the expected theoretical output voltage $V_{out-th} = Av \cdot V_{sense}$. See [Chapter 5](#) for a more detailed definition.
3. Except for Av = 100 V/V.

Table 7. Frequency response

Symbol	Parameter	Test conditions	Min.	Typ.	Max.	Unit
ts	Output settling to 1% of final value	$V_{\text{sense}} = 10 \text{ mV to } 100 \text{ mV}$, $C_{\text{load}} = 47 \text{ pF}$				
		$A_v = 50 \text{ V/V}$		6		μs
		$A_v = 100 \text{ V/V}$		10		μs
t _{SEL}	Output settling to 1% of final value	Any change of state of SEL		1		μs
t _{rec}	Response to common-mode voltage change. Output settling to 1% of final value	$V_{\text{CC}+} = 5 \text{ V}$, $V_{\text{CC}-} = -5 \text{ V}$ V_m step change from -2 V to 30 V or 30 V to -2 V		20		μs
SR	Slew rate	$V_{\text{sense}} = 10 \text{ mV to } 100 \text{ mV}$	0.4	0.6		V/ μs
BW	3 dB bandwidth	$C_{\text{load}} = 47 \text{ pF}$ $V_{\text{icm}} = 12 \text{ V}$ $V_{\text{sense}} = 50 \text{ mV}$ $A_v = 50 \text{ V/V}$		700		kHz

Table 8. Noise

Symbol	Parameter	Test conditions	Min.	Typ.	Max.	Unit
eN	Equivalent input noise voltage	f = 1 kHz		40		nV/ $\sqrt{\text{Hz}}$

4 Electrical characteristics curves: current sense amplifier

Unless otherwise specified, the test conditions for the following curves are:

- $T_{amb} = 25^{\circ}\text{C}$, $V_{CC} = 5\text{ V}$, $V_{sense} = V_p - V_m = 50\text{ mV}$, $V_m = 12\text{ V}$.
- No load on Out pin.

Figure 4. Output voltage vs. V_{sense}

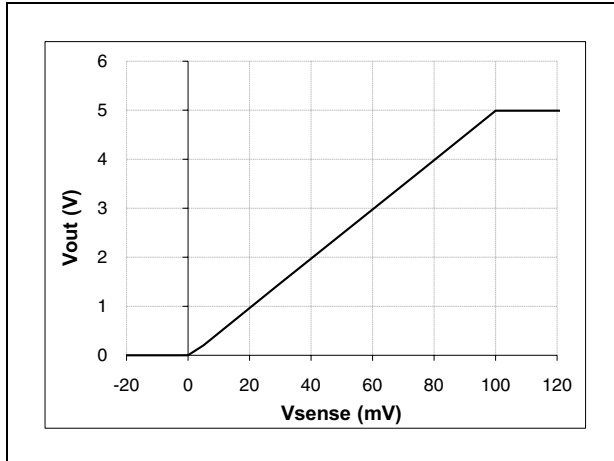

Figure 5. Output voltage accuracy vs. V_{sense}

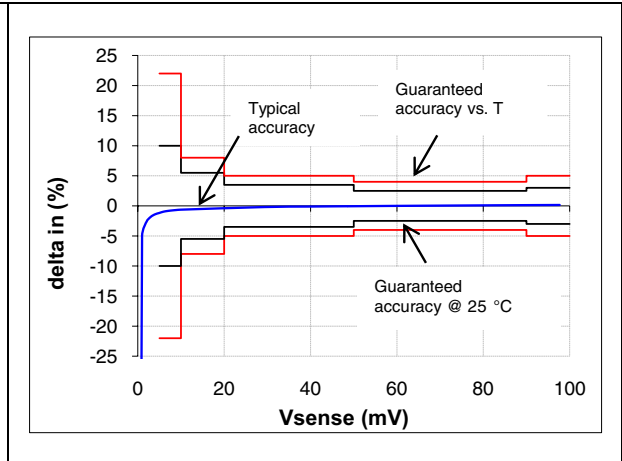

Figure 6. Supply current vs. supply voltage

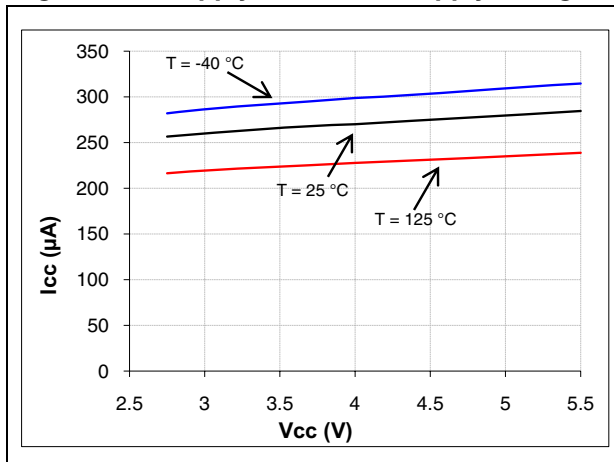

Figure 7. Supply current vs. V_{sense}

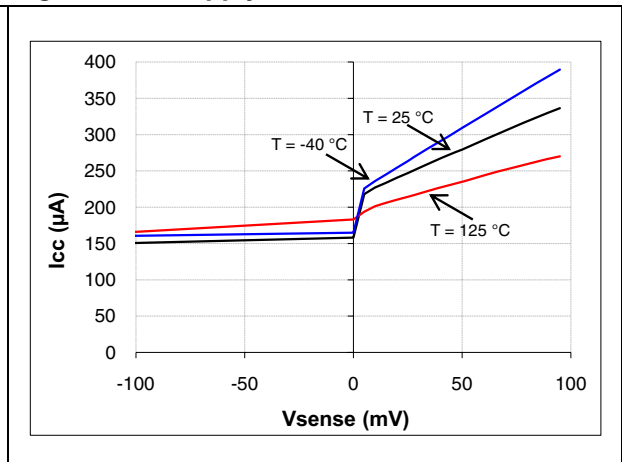

Figure 8. Vp pin input current vs. Vsense

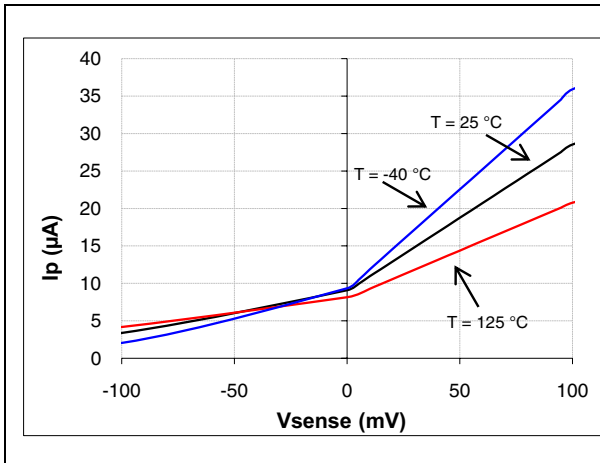

Figure 9. Vn pin input current vs. Vsense

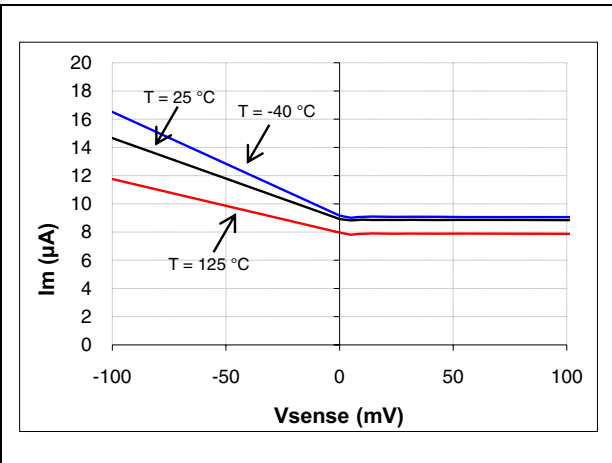

Figure 10. Output stage low-state saturation voltage vs. output current (Vsense = -1 V)

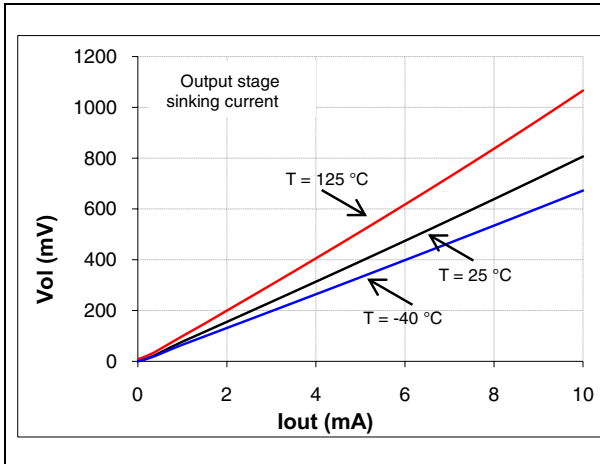

Figure 11. Output stage high-state saturation voltage vs. output current (Vsense = +1 V)

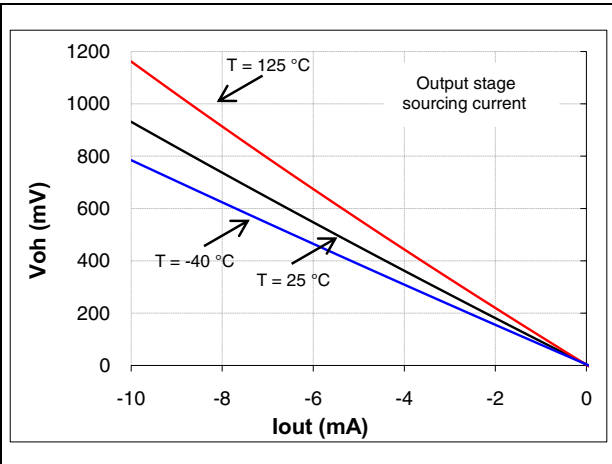

Figure 12. Output stage load regulation

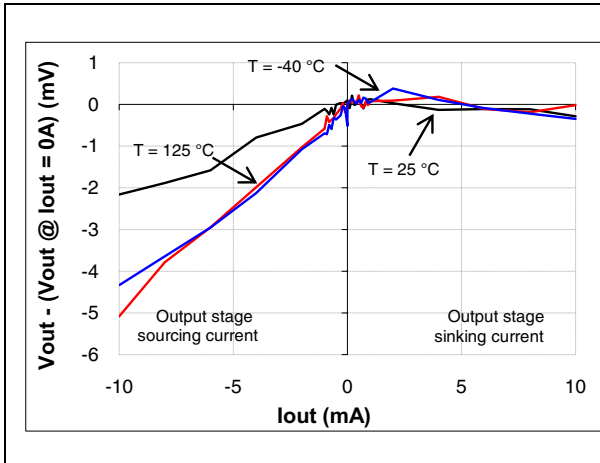

Figure 13. Step response

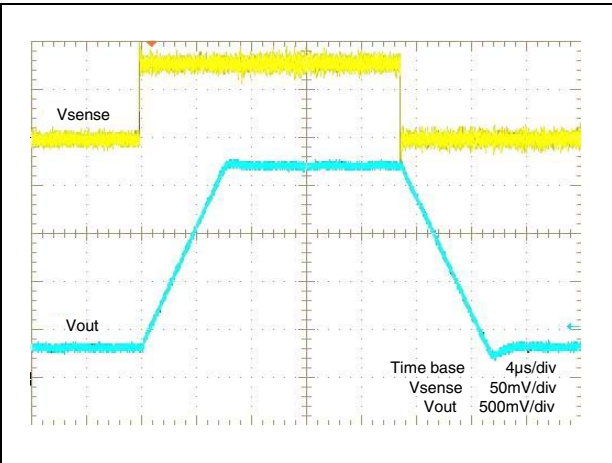

Figure 14. Bode diagram

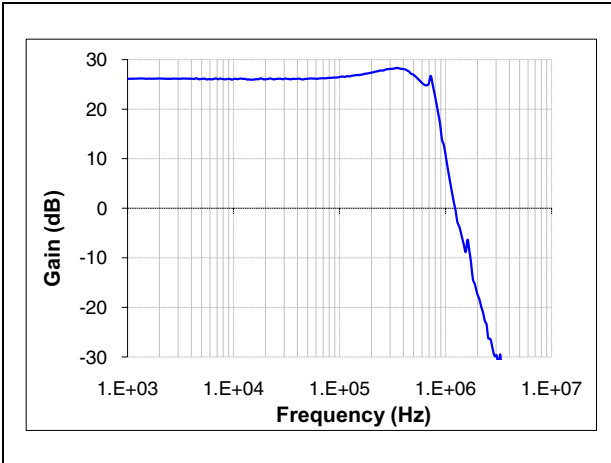

Figure 15. Power supply rejection ratio

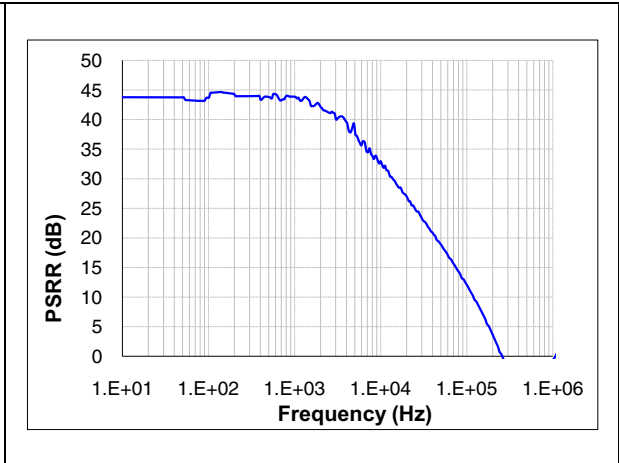
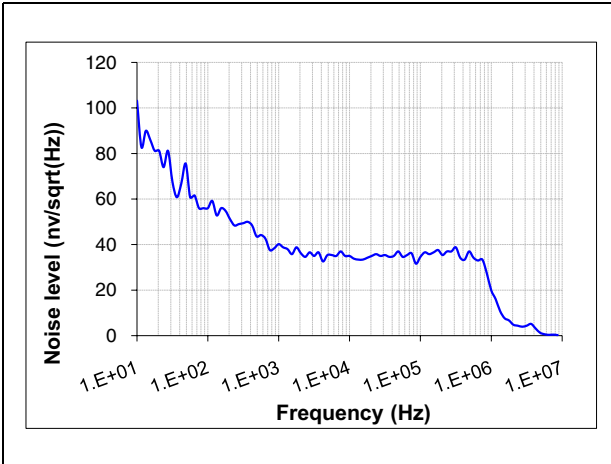

Figure 16. Noise Level



5 Parameter definitions

5.1 Common mode rejection ratio (CMR)

The common mode rejection ratio (CMR) measures the ability of the current sensing amplifier to reject any DC voltage applied on both inputs V_p and V_m . The CMR is referred back to the input so that its effect can be compared with the applied differential signal. The CMR is defined by the formula:

$$\text{CMR} = -20 \cdot \log \frac{\Delta V_{\text{out}}}{\Delta V_{\text{icm}} \cdot A_v}$$

5.2 Supply voltage rejection ratio (SVR)

The supply voltage rejection ratio (SVR) measures the ability of the current-sensing amplifier to reject any variation of the supply voltage V_{CC} . The SVR is referred back to the input so that its effect can be compared with the applied differential signal. The SVR is defined by the formula:

$$\text{SVR} = -20 \cdot \log \frac{\Delta V_{\text{out}}}{\Delta V_{CC} \cdot A_v}$$

5.3 Gain (A_v) and input offset voltage (V_{os})

The input offset voltage is defined as the intersection between the linear regression of the V_{out} vs. V_{sense} curve with the X-axis (see [Figure 17](#)). If V_{out1} is the output voltage with $V_{\text{sense}} = V_{\text{sense1}}$ and V_{out2} is the output voltage with $V_{\text{sense}} = V_{\text{sense2}}$, then V_{os} can be calculated with the following formula.

$$V_{os} = V_{\text{sense1}} - \left(\frac{V_{\text{sense1}} - V_{\text{sense2}}}{V_{\text{out1}} - V_{\text{out2}}} \cdot V_{\text{out1}} \right)$$

Figure 17. V_{out} versus V_{sense} characteristics: detail for low V_{sense} values

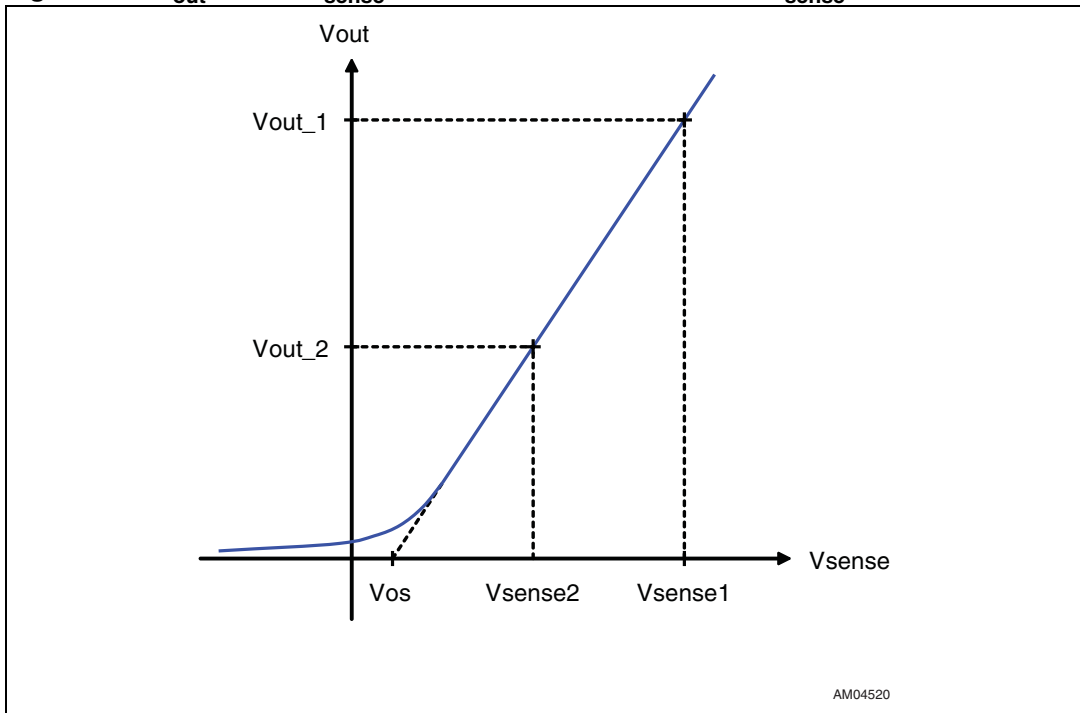

The values of V_{sense1} and V_{sense2} used for the input offset calculations are detailed in [Table 9](#).

Table 9. Test conditions for V_{os} voltage calculation

A_v (V/V)	V_{sense1} (mV)	V_{sense2} (mV)
50	50	5
100	40	5

5.4 Output voltage drift versus temperature

The output voltage drift versus temperature is defined as the maximum variation of V_{out} with respect to its value at 25° C over the temperature range. It is calculated as follows:

$$\frac{\Delta V_{out}}{\Delta T} = \max \frac{V_{out}(T_{amb}) - V_{out}(25^{\circ}C)}{T_{amb} - 25^{\circ}C}$$

with $T_{min} < T_{amb} < T_{max}$.

Figure 18 provides a graphical definition of the output voltage drift versus temperature. On this chart V_{out} is always within the area defined by the maximum and minimum variation of V_{out} versus T , and $T = 25^{\circ}C$ is considered to be the reference.

Figure 18. Output voltage drift versus temperature ($A_v = 50 V/V$ $V_{sense} = 50 mV$)

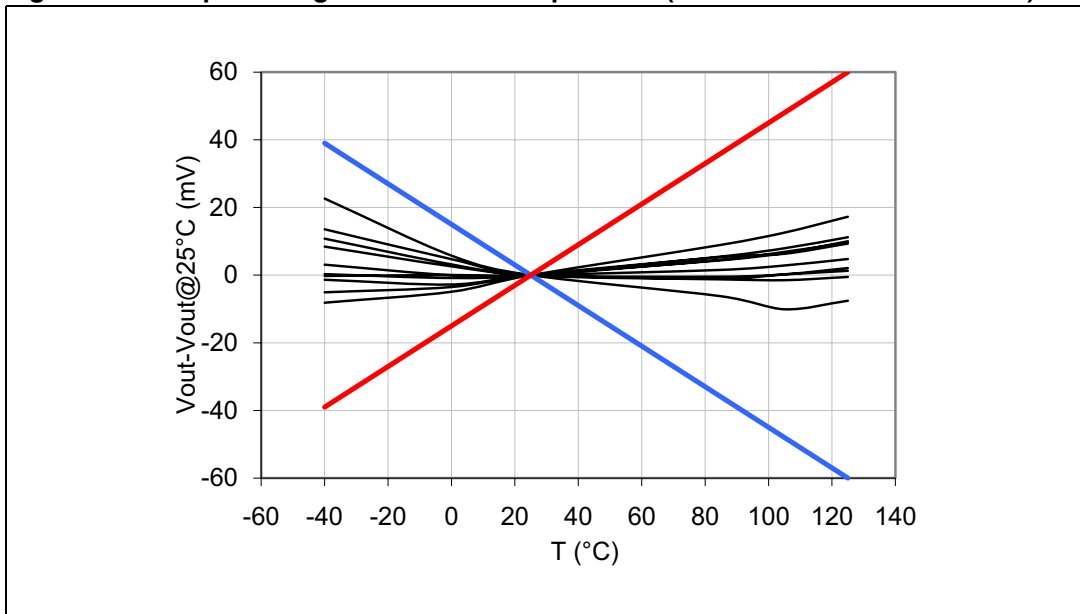

5.5 Input offset drift versus temperature

The input voltage drift versus temperature is defined as the maximum variation of V_{os} with respect to its value at 25° C over the temperature range. It is calculated as follows:

$$\frac{\Delta V_{os}}{\Delta T} = \max \frac{V_{os}(T_{amb}) - V_{os}(25^\circ C)}{T_{amb} - 25^\circ C}$$

with $T_{min} < T_{amb} < T_{max}$.

Figure 19. provides a graphical definition of the input offset drift versus temperature. On this chart V_{os} is always comprised in the area defined by the maximum and minimum variation of V_{os} versus T, and $T = 25^\circ C$ is considered to be the reference.

Figure 19. Input offset drift versus temperature ($A_v = 50 V/V$)

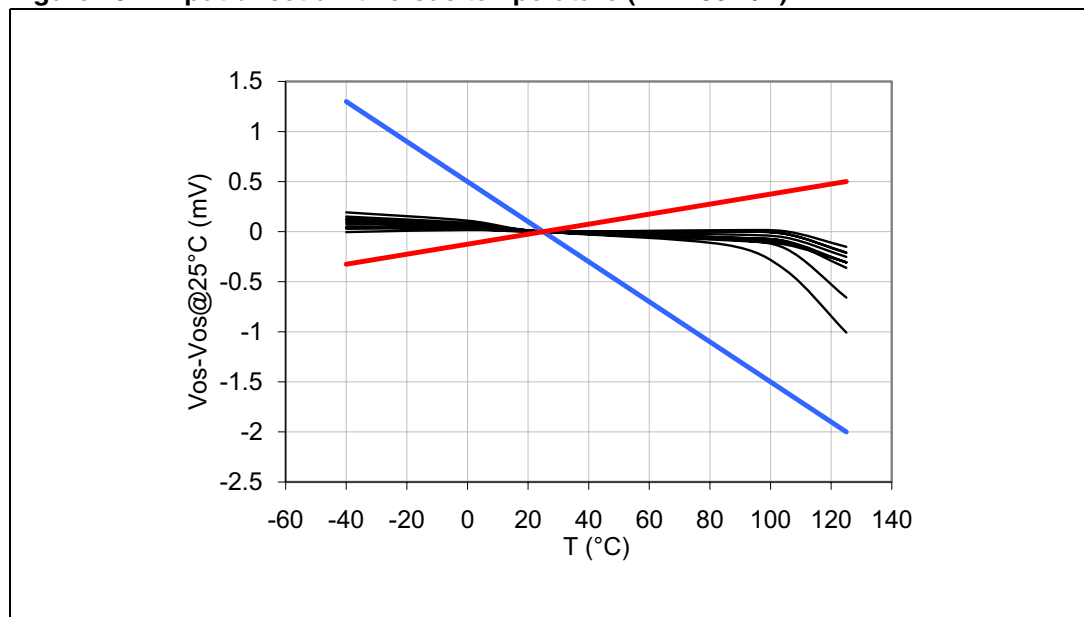

5.6 Output voltage accuracy

The output voltage accuracy is the difference between the actual output voltage and the theoretical output voltage. Ideally, the current sensing output voltage should be equal to the input differential voltage multiplied by the theoretical gain, as in the following formula.

$$V_{out-th} = A_v \cdot V_{sense}$$

The actual value is very slightly different, mainly due to the effects of:

- the input offset voltage V_{os} ,
- the non-linearity.

Figure 20. Vout vs. Vsense theoretical and actual characteristics

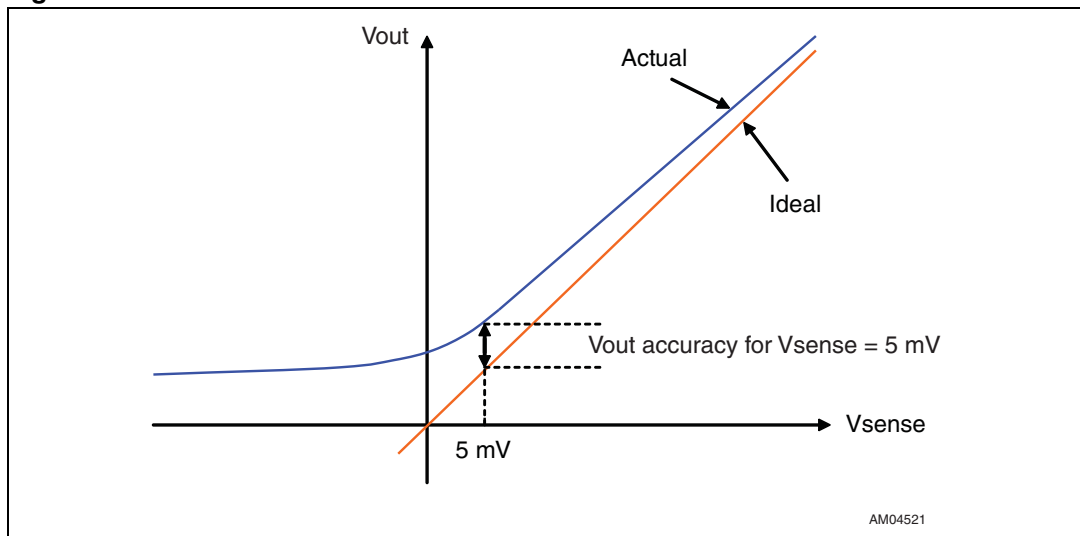

The output voltage accuracy, expressed as a percentage, can be calculated with the following formula,

$$\Delta V_{\text{out}} = \frac{\text{abs}(V_{\text{out}} - (A_v \cdot V_{\text{sense}}))}{A_v \cdot V_{\text{sense}}}$$

with 50 V/V or 100 V/V depending on the configuration of the SEL pin.

6 Maximum permissible voltages on pins

The TSC1031 can be used in either single or dual supply configuration. The dual-supply configuration is achieved by disconnecting Vcc- and Gnd, and connecting Vcc- to a negative supply. *Figure 21* illustrates how the absolute maximum voltages on input pins Vp and Vm are referred to the Vcc- potential, while the maximum voltages on the positive supply pin, gain selection pins and output pins are referred to the Gnd pin. It should also be noted that the maximum voltage between Vcc- and Vcc+ is limited to 15 V.

Figure 21. Maximum voltages on pins

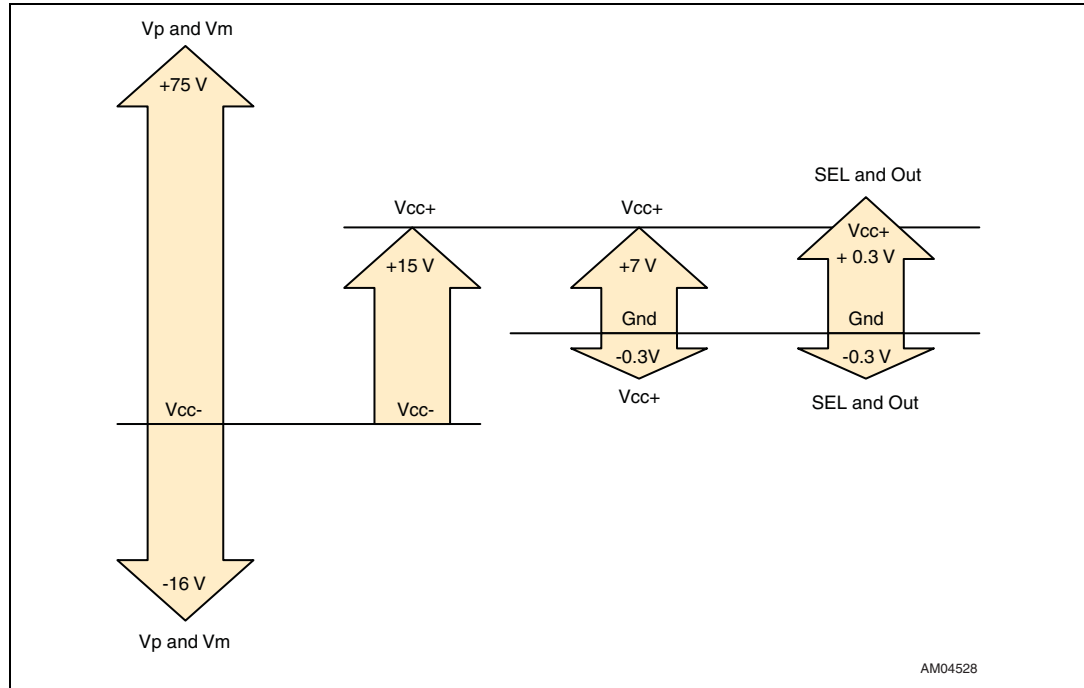

7 Application information

The TSC1031 can be used to measure current and to feed back the information to a microcontroller.

Figure 22. Typical application

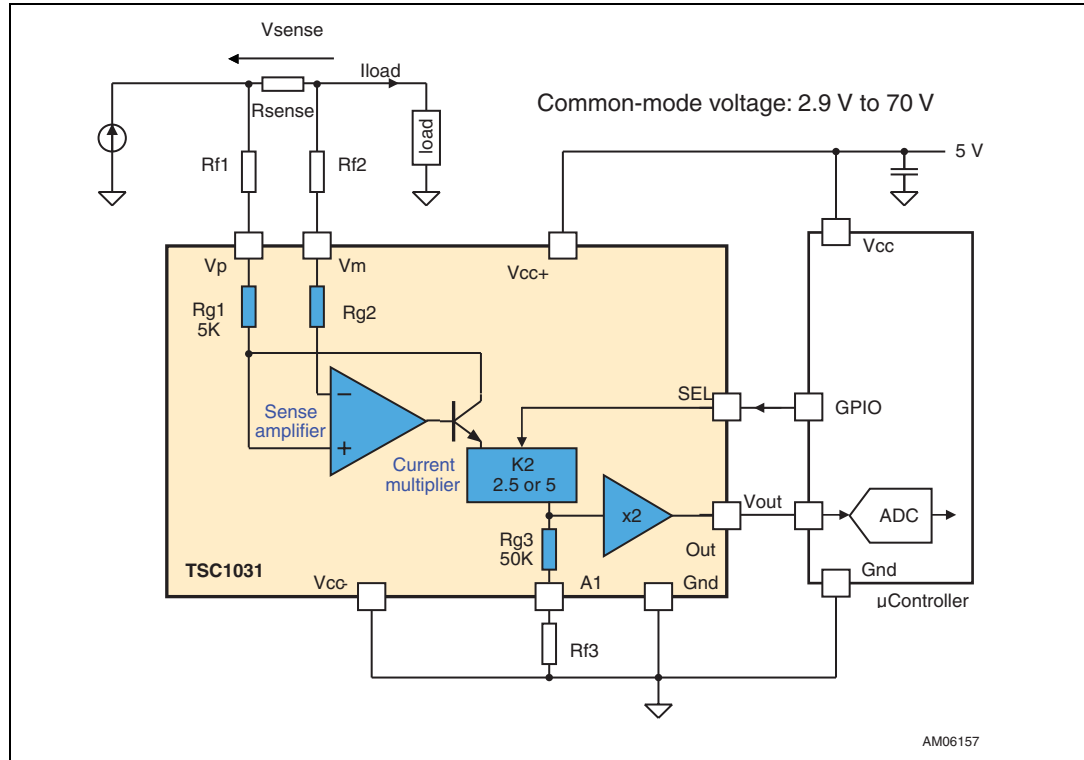

The current from the supply flows to the load through the R_{sense} resistor causing a voltage drop equal to V_{sense} across R_{sense} . The amplifier's input currents are negligible, therefore its inverting input voltage is equal to V_m . The amplifier's open-loop gain forces its non-inverting input to the same voltage as the inverting input. As a consequence, the amplifier adjusts current flowing through R_{g1} so that the voltage drop across R_{g1} exactly matches V_{sense} .

Therefore, the drop across R_{g1} is:

$$V_{R_{g1}} = V_{sense} = R_{sense} \cdot I_{load}$$

If $I_{R_{g1}}$ is the current flowing through R_{g1} , then $I_{R_{g1}}$ is given by the formula:

$$I_{R_{g1}} = V_{sense} / R_{g1}$$

The $I_{R_{g1}}$ current flows is multiplied by a ratio $K2$ and the resulting current flows into resistor R_{g3} . Therefore, the voltage drop on the R_{g3} resistor can be calculated as follows.

$$V_{R_{g3}} = R_{g3} \cdot K2 \cdot I_{R_{g1}} = (R_{g3} / R_{g1}) \cdot K2 \cdot V_{sense} = K1 \cdot K2 \cdot V_{sense} \text{ with } K1 = R_{g3} / R_{g1} = 10.$$

The voltage across the R_{g3} resistor is buffered to the Out pin by the voltage buffer, featuring a gain equal to 2. Therefore V_{out} can be expressed as:

$$V_{out} = 2 \cdot K1 \cdot K2 \cdot V_{sense} = A_v \cdot V_{sense} \text{ with } A_v = 2 \cdot K1 \cdot K2$$

or: $V_{out} = A_v \cdot R_{sense} \cdot I_{load}$

The current multiplier gain K2 can be set to 2.5 or 5 depending on the voltage applied on the SEL pin.

Since they define the full-scale output range of the application, the R_{sense} resistor and the amplification gain A_v are important parameters and must therefore be selected carefully.

The TSC1031's dedicated schematic eases the implementation of EMI filtering in harsh environments. A simple filter is described in [Figure 22](#), where the input filtering is performed by R_{f1} , R_{f2} and C_f .

The values of R_{f1} and R_{f2} should be equal so as to balance the contribution on both amplifier inputs. The value of the C_f capacitor should be selected so that the cut-off frequency of the first-order low-pass filter provides enough attenuation to the high frequency interferences.

To balance the contribution of R_{f1} and R_{f2} in the current sense amplifier gain, an output resistor R_{f3} should be connected between pin A1 and Gnd. The value of R_{f3} should be chosen according to the following formula.

$$K1 = 10 = R_{g3}/R_{g1} = R_{f3}/R_{f1} = R_{f3}/R_{f2}$$

If these precautions having been taken, the TSC1031's gain is unaffected by the implementation of the input filtering resistors.

8 Package information

In order to meet environmental requirements, ST offers these devices in different grades of ECOPACK[®] packages, depending on their level of environmental compliance. ECOPACK[®] specifications, grade definitions and product status are available at: www.st.com. ECOPACK[®] is an ST trademark.

8.1 SO-8 package information

Figure 23. SO-8 package mechanical drawing

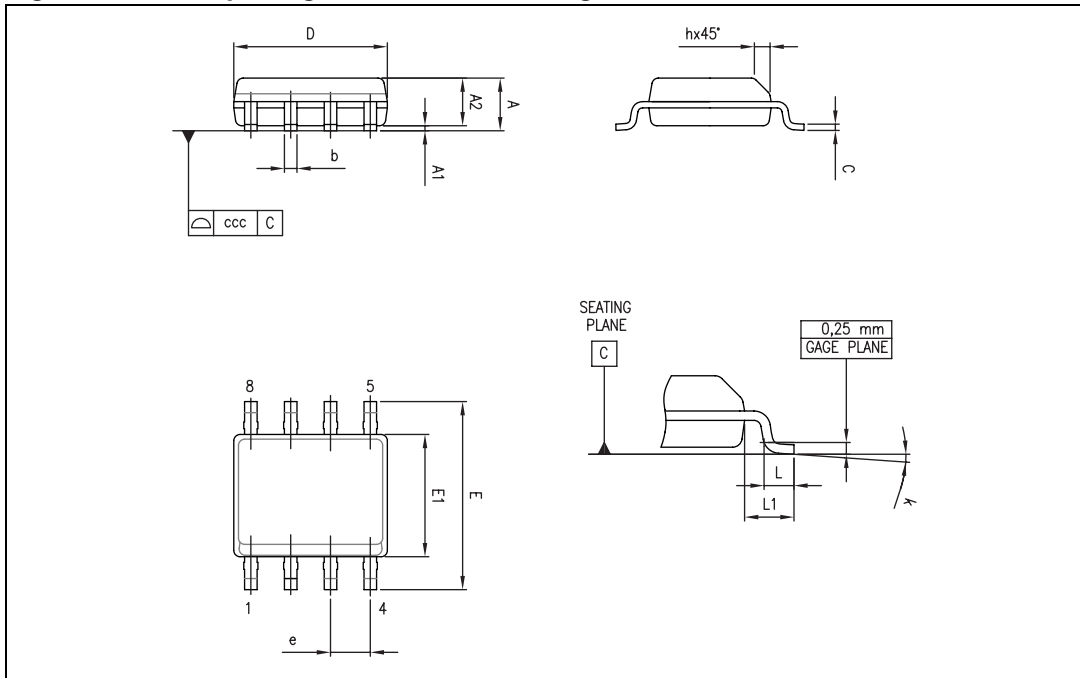

Table 10. SO-8 package mechanical data

Ref.	Dimensions					
	Millimeters			Inches		
	Min.	Typ.	Max.	Min.	Typ.	Max.
A			1.75			0.069
A1	0.10		0.25	0.004		0.010
A2	1.25			0.049		
b	0.28		0.48	0.011		0.019
c	0.17		0.23	0.007		0.010
D	4.80	4.90	5.00	0.189	0.193	0.197
E	5.80	6.00	6.20	0.228	0.236	0.244
E1	3.80	3.90	4.00	0.150	0.154	0.157
e		1.27			0.050	
h	0.25		0.50	0.010		0.020
L	0.40		1.27	0.016		0.050
L1		1.04			0.040	
k	0		8°	1°		8°
ccc			0.10			0.004

8.2 TSSOP-8 package information

Figure 24. TSSOP8 package mechanical drawing

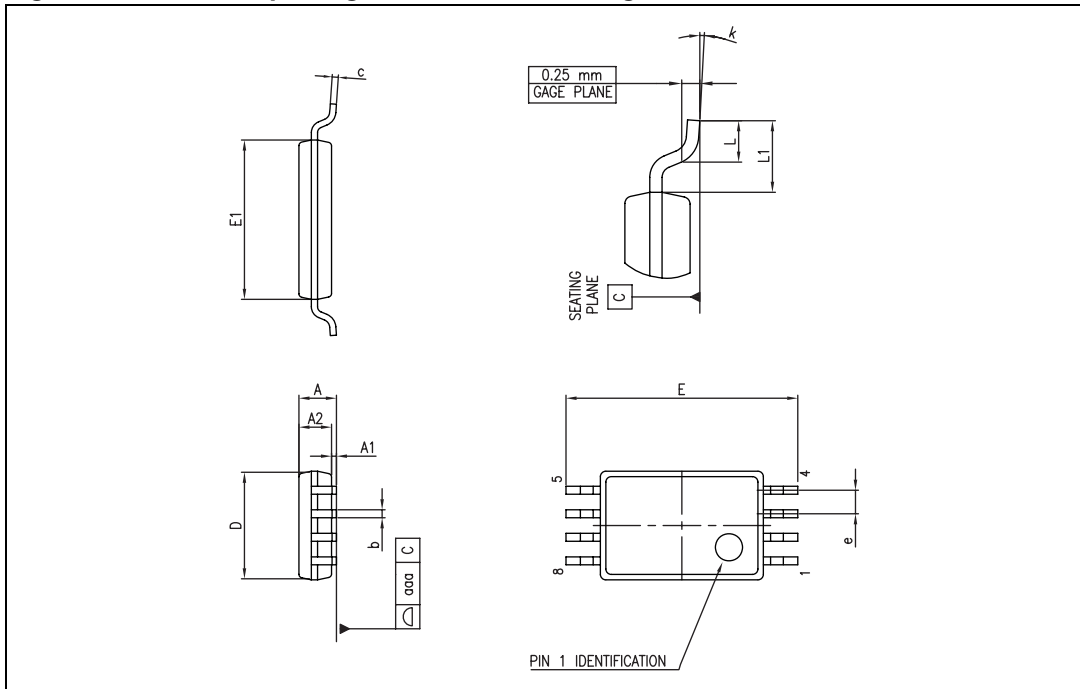

Table 11. TSSOP8 package mechanical data

Ref.	Dimensions					
	Millimeters			Inches		
	Min.	Typ.	Max.	Min.	Typ.	Max.
A			1.20			0.047
A1	0.05		0.15	0.002		0.006
A2	0.80	1.00	1.05	0.031	0.039	0.041
b	0.19		0.30	0.007		0.012
c	0.09		0.20	0.004		0.008
D	2.90	3.00	3.10	0.114	0.118	0.122
E	6.20	6.40	6.60	0.244	0.252	0.260
E1	4.30	4.40	4.50	0.169	0.173	0.177
e		0.65			0.0256	
k	0°		8°	0°		8°
L	0.45	0.60	0.75	0.018	0.024	0.030
L1		1			0.039	
aaa			0.10			0.004

9 Ordering information

Table 12. Order codes

Part number	Temperature range	Package	Packaging	Marking
TSC1031IPT	-40°C, +125°C	TSSOP8	Tape & reel	1031I
TSC1031IDT		SO-8	Tape & reel	TSC1031I
TSC1031IYPT	-40°C, +125°C Automotive grade	TSSOP8 ⁽¹⁾	Tape & reel	1031Y
TSC1031IYDT		SO-8 ⁽²⁾	Tape & reel	TSC1031Y

1. Qualification and characterization according to AEC Q100 and Q003 or equivalent, advanced screening according to AEC Q001 & Q002 or equivalent are on-going.
2. Qualification and characterization according to AEC Q100 and Q003 or equivalent, advanced screening according to AEC Q001 & Q002 or equivalent.

10 Revision history

Table 13. Document revision history

Date	Revision	Changes
04-Jan-2010	1	Initial release.
29-Apr-2011	2	Added <i>Chapter 4: Electrical characteristics curves: current sense amplifier</i> . Changed <i>Figure 4</i> to <i>Figure 16</i> . Modified <i>Figure 22: Typical application</i> . Added automotive grade qualification for SO-8 package in <i>Table 12: Order codes</i> .

Please Read Carefully:

Information in this document is provided solely in connection with ST products. STMicroelectronics NV and its subsidiaries ("ST") reserve the right to make changes, corrections, modifications or improvements, to this document, and the products and services described herein at any time, without notice.

All ST products are sold pursuant to ST's terms and conditions of sale.

Purchasers are solely responsible for the choice, selection and use of the ST products and services described herein, and ST assumes no liability whatsoever relating to the choice, selection or use of the ST products and services described herein.

No license, express or implied, by estoppel or otherwise, to any intellectual property rights is granted under this document. If any part of this document refers to any third party products or services it shall not be deemed a license grant by ST for the use of such third party products or services, or any intellectual property contained therein or considered as a warranty covering the use in any manner whatsoever of such third party products or services or any intellectual property contained therein.

UNLESS OTHERWISE SET FORTH IN ST'S TERMS AND CONDITIONS OF SALE ST DISCLAIMS ANY EXPRESS OR IMPLIED WARRANTY WITH RESPECT TO THE USE AND/OR SALE OF ST PRODUCTS INCLUDING WITHOUT LIMITATION IMPLIED WARRANTIES OF MERCHANTABILITY, FITNESS FOR A PARTICULAR PURPOSE (AND THEIR EQUIVALENTS UNDER THE LAWS OF ANY JURISDICTION), OR INFRINGEMENT OF ANY PATENT, COPYRIGHT OR OTHER INTELLECTUAL PROPERTY RIGHT.

UNLESS EXPRESSLY APPROVED IN WRITING BY AN AUTHORIZED ST REPRESENTATIVE, ST PRODUCTS ARE NOT RECOMMENDED, AUTHORIZED OR WARRANTED FOR USE IN MILITARY, AIR CRAFT, SPACE, LIFE SAVING, OR LIFE SUSTAINING APPLICATIONS, NOR IN PRODUCTS OR SYSTEMS WHERE FAILURE OR MALFUNCTION MAY RESULT IN PERSONAL INJURY, DEATH, OR SEVERE PROPERTY OR ENVIRONMENTAL DAMAGE. ST PRODUCTS WHICH ARE NOT SPECIFIED AS "AUTOMOTIVE GRADE" MAY ONLY BE USED IN AUTOMOTIVE APPLICATIONS AT USER'S OWN RISK.

Resale of ST products with provisions different from the statements and/or technical features set forth in this document shall immediately void any warranty granted by ST for the ST product or service described herein and shall not create or extend in any manner whatsoever, any liability of ST.

ST and the ST logo are trademarks or registered trademarks of ST in various countries.

Information in this document supersedes and replaces all information previously supplied.

The ST logo is a registered trademark of STMicroelectronics. All other names are the property of their respective owners.

© 2011 STMicroelectronics - All rights reserved

STMicroelectronics group of companies

Australia - Belgium - Brazil - Canada - China - Czech Republic - Finland - France - Germany - Hong Kong - India - Israel - Italy - Japan - Malaysia - Malta - Morocco - Philippines - Singapore - Spain - Sweden - Switzerland - United Kingdom - United States of America

www.st.com