

Sensitive gate 4 A SCRs

Features

- On-state rms current, 4 A
- Repetitive peak off-state voltages, 600 and 700 V
- Triggering gate current, 0.2 mA

Description

Thanks to highly sensitive triggering levels, the TS420 series is suitable for all applications where the available gate current is limited, such as motor control for hand tools, kitchen aids, overvoltage crowbar protection for low power supplies among others.

Available in through-hole or surface-mount packages, they provide an optimized performance in a limited space area.

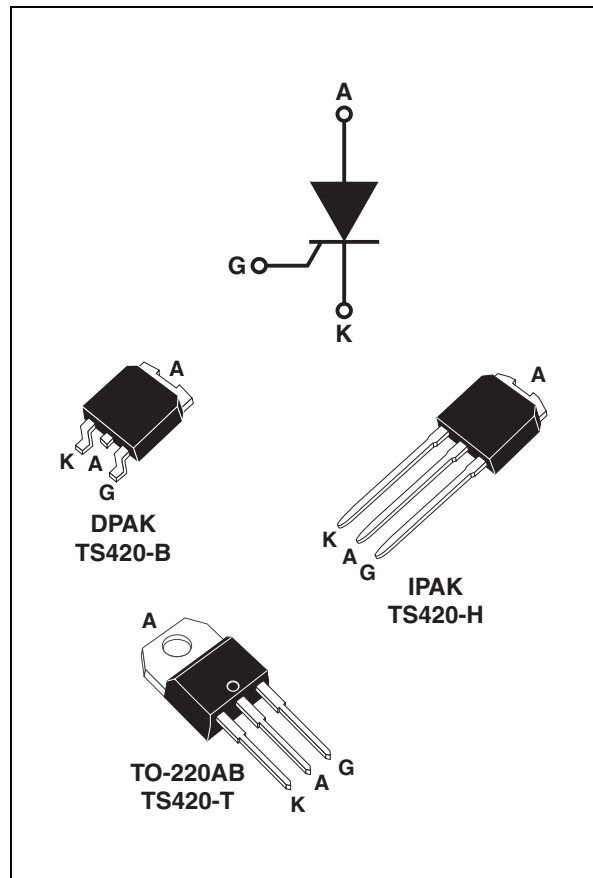

Table 1. Device summary

| Order code | Voltage (xxx) | | Sensitivity | Package |
|------------|---------------|-------|-------------|----------|
| | 600 V | 700 V | | |
| TS420-xxxB | X | X | 0.2 mA | DPAK |
| TS420-xxxH | X | X | 0.2 mA | IPAK |
| TS420-xxxT | X | X | 0.2 mA | TO-220AB |

1 Characteristics

Table 2. Absolute ratings (limiting values)

| Symbol | Parameter | | Value | Unit |
|--------------|--|-------------------------|-----------------------|-----------|
| $I_{T(RMS)}$ | On-state rms current (180° conduction angle) | | $T_I = 115\text{ °C}$ | A |
| $I_{T(AV)}$ | Average on-state current (180° conduction angle) | | $T_I = 115\text{ °C}$ | A |
| I_{TSM} | Non repetitive surge peak on-state current | $t_p = 8.3\text{ ms}$ | $T_j = 25\text{ °C}$ | 33 |
| | | $t_p = 10\text{ ms}$ | | 30 |
| I^2t | I^2t Value for fusing | $t_p = 10\text{ ms}$ | $T_j = 25\text{ °C}$ | A^2s |
| di/dt | Critical rate of rise of on-state current $I_G = 2 \times I_{GT}, t_r \leq 100\text{ ns}$ | $F = 60\text{ Hz}$ | $T_j = 125\text{ °C}$ | $A/\mu s$ |
| I_{GM} | Peak gate current | $t_p = 20\text{ }\mu s$ | $T_j = 125\text{ °C}$ | A |
| $P_{G(AV)}$ | Average gate power dissipation | | $T_j = 125\text{ °C}$ | W |
| T_{stg} | Storage junction temperature range | | - 40 to + 150 | °C |
| T_j | Operating junction temperature range | | - 40 to + 125 | |
| V_{RGM} | Maximum peak reverse gate voltage | | 5 | V |

Table 3. Device timings

| Symbol | Parameter | Test conditions | Value | Unit |
|----------|----------------------------------|---|------------|---------|
| t_{GT} | Gate controlled turn on time | $I_{TM} = 10\text{ A}, V_D = V_{DRM(max)}, I_{GT} = 10\text{ mA}, di_G/dt = 0.2\text{ A}/\mu s, R_G = 1\text{ k}\Omega, T_j = 25\text{ °C}$ | 0.5 (Typ.) | μs |
| t_Q | Circuit controlled turn off time | $V_D = 67\% V_{DRM(max)}, T_j = 125\text{ °C}, I_{TM} = 8\text{ A}, V_R = 10\text{ V}, di_T/dt = 10\text{ A}/\mu s, dV_D/dt = 2\text{ V}/\mu s, R_G = 1\text{ k}\Omega$ | 60 (Typ.) | |

Table 4. Electrical characteristics ($T_j = 25\text{ °C}$, unless otherwise specified)

| Symbol | Test conditions | | Value | Unit | | |
|------------------------|---|-----------------------|-----------------------|---------------|------------------|------------|
| I_{GT} | $V_D = 12\text{ V}$, $R_L = 33\ \Omega$ | MAX. | 200 | μA | | |
| V_{GT} | | MAX. | 0.8 | V | | |
| V_{GD} | $V_D = V_{DRM}$, $R_L = 33\ \text{k}\Omega$, $R_{GK} = 220\ \Omega$ | $T_j = 125\text{ °C}$ | MIN. | 0.1 | V | |
| V_{RG} | $I_{RG} = 10\ \mu\text{A}$ | | MIN. | 8 | V | |
| I_H | $I_T = 50\ \text{mA}$, $R_{GK} = 1\ \text{k}\Omega$ | | MAX. | 5 | mA | |
| I_L | $I_G = 1\ \text{mA}$, $R_{GK} = 1\ \text{k}\Omega$ | | MAX. | 6 | mA | |
| dV/dt | $V_D = 67\% V_{DRM}$, $R_{GK} = 220\ \Omega$ | $T_j = 125\text{ °C}$ | MIN. | 5 | V/ μs | |
| V_{TM} | $I_{TM} = 8\ \text{A}$, $t_p = 380\ \mu\text{s}$ | $T_j = 25\text{ °C}$ | MAX. | 1.6 | V | |
| V_{t0} | Threshold voltage | | $T_j = 125\text{ °C}$ | MAX. | 0.85 | V |
| R_d | Dynamic resistance | | $T_j = 125\text{ °C}$ | MAX. | 90 | m Ω |
| I_{DRM} I_{RRM} | $V_{DRM} = V_{RRM}$, $R_{GK} = 220\ \Omega$ | $T_j = 25\text{ °C}$ | MAX. | 5 | μA | |
| | | $T_j = 125\text{ °C}$ | | 1 | mA | |

Table 5. Thermal resistance

| Symbol | Parameter | | Value | Unit | |
|---------------|--------------------------|------------------------------|----------|-----------------------------|-----------------------------|
| $R_{th(j-c)}$ | Junction to case (DC) | | 3.0 | $^{\circ}\text{C}/\text{W}$ | |
| $R_{th(j-a)}$ | Junction to ambient (DC) | $S^{(1)} = 0.5\ \text{cm}^2$ | DPAK | 70 | $^{\circ}\text{C}/\text{W}$ |
| | | | IPAK | 100 | |
| | | | TO-220AB | 60 | |

1. Copper under surface tab

Figure 1. Maximum average power dissipation versus average on-state current

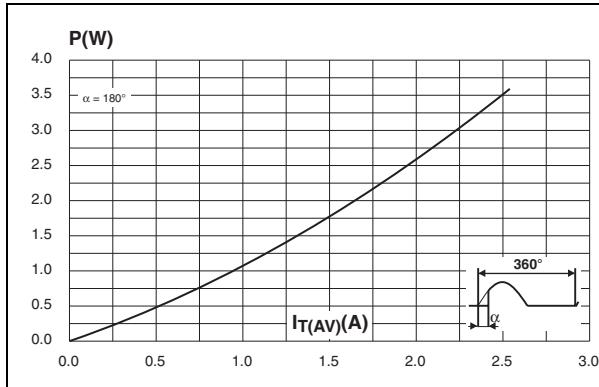

Figure 2. Average and DC on-state current versus case temperature

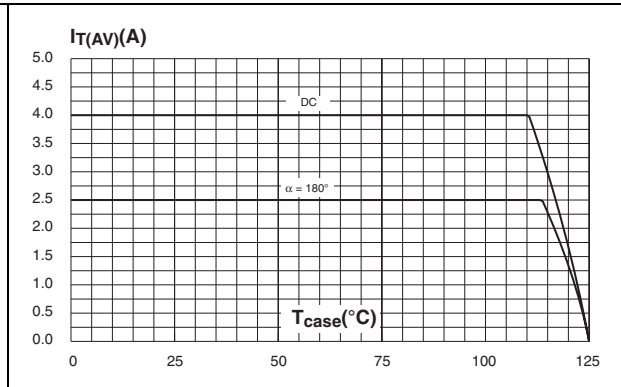

Figure 3. Average and DC on-state current versus ambient temperature (DPAK)

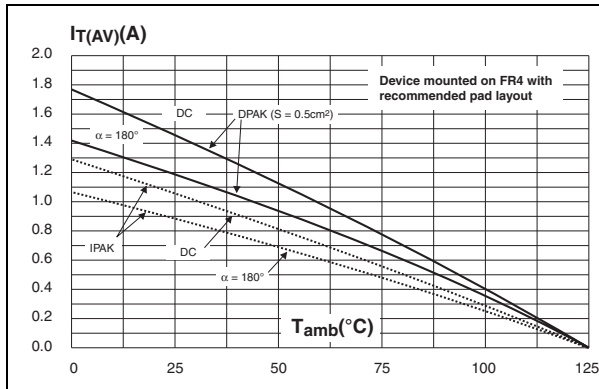

Figure 4. Relative variation of thermal impedance junction to ambient versus pulse duration (DPAK)

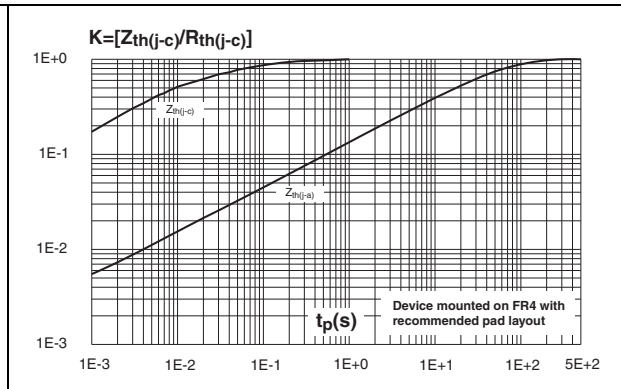

Figure 5. Relative variation of gate trigger current and holding current versus junction temperature

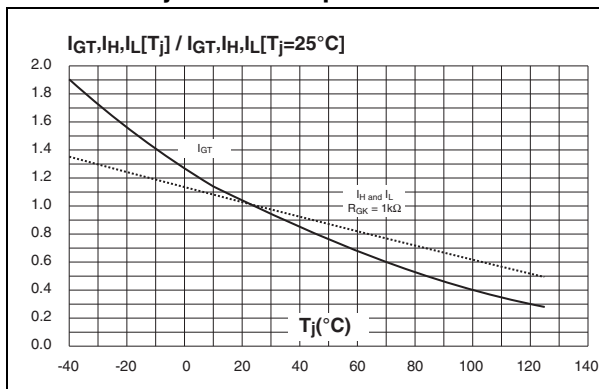

Figure 6. Relative variation of holding current versus gate-cathode resistance (typical values)

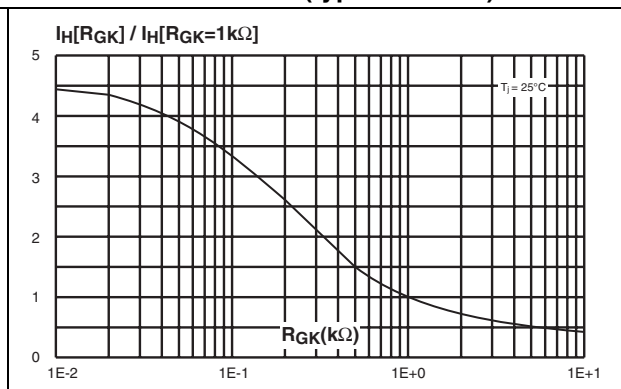

Figure 7. Relative variation of dV/dt immunity versus gate-cathode resistance (typical values)

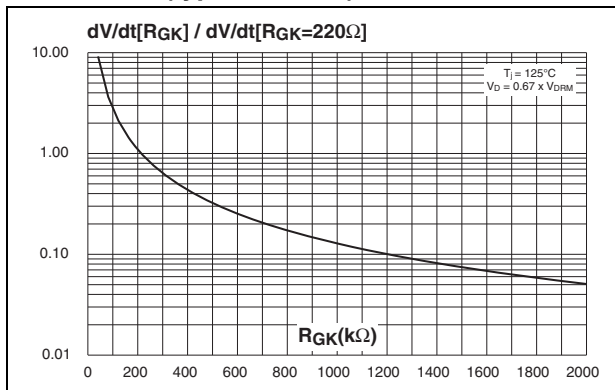

Figure 8. Relative variation of dV/dt immunity versus gate-cathode capacitance (typical values)

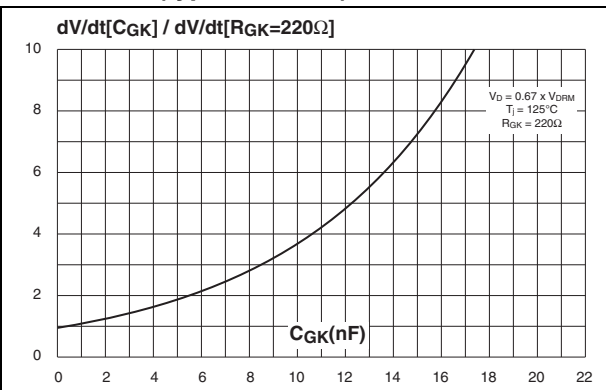

Figure 9. Surge peak on-state current versus number of cycles

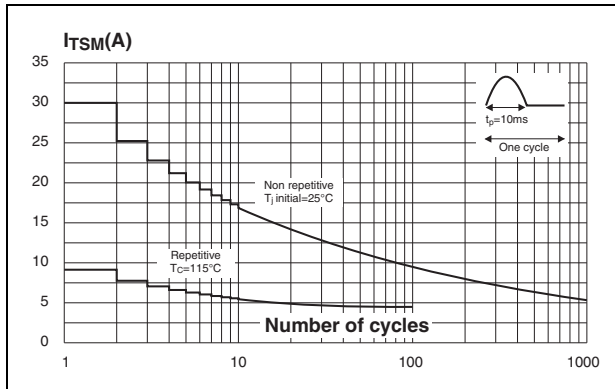

Figure 10. Non-repetitive surge peak on-state current, and corresponding values of I²t

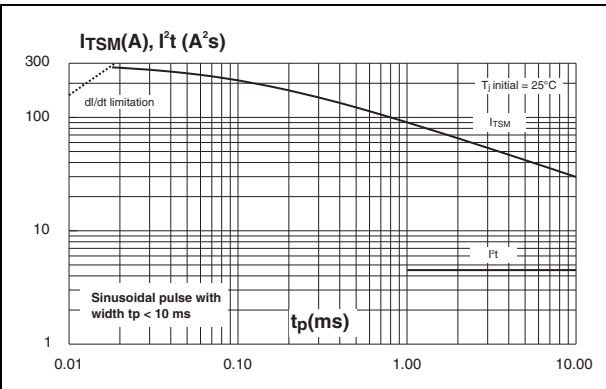

Figure 11. On-state characteristics (maximum values)

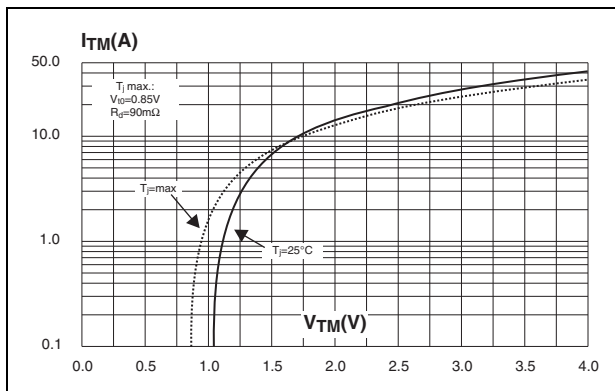
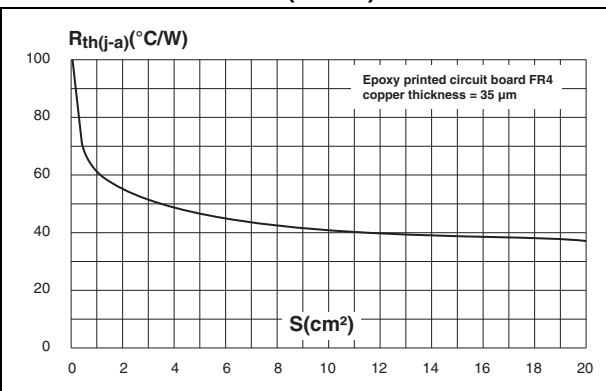
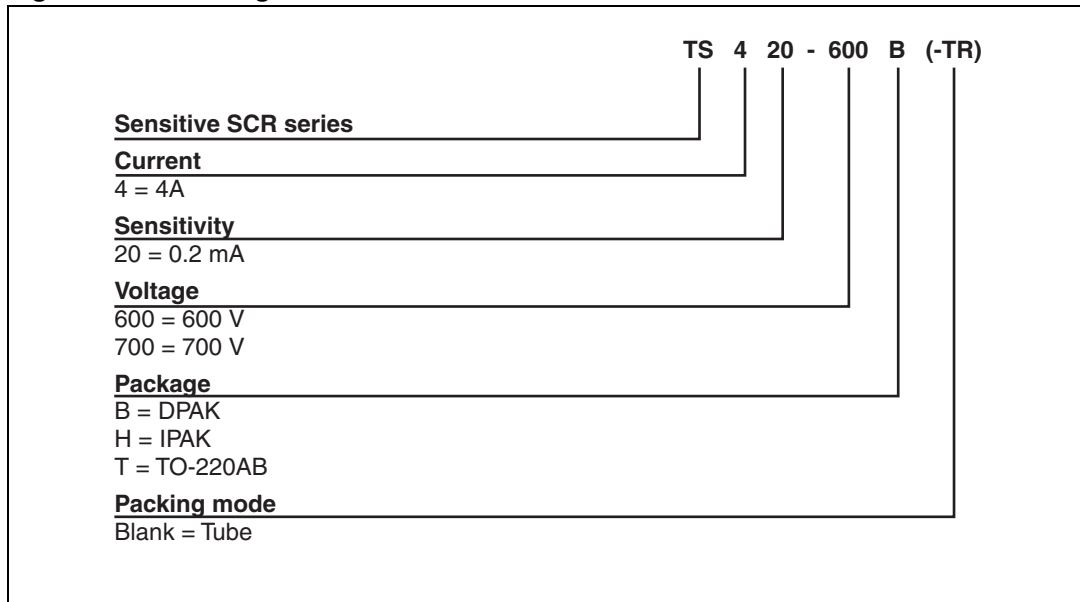

Figure 12. Thermal resistance junction to ambient versus copper surface under tab (DPAK)



2 Ordering information scheme

Figure 13. Ordering information scheme



3 Package information

- Epoxy meets UL94, V0
- Recommended torque 0.4 to 0.6 N·m (TO-220AB)

In order to meet environmental requirements, ST offers these devices in different grades of ECOPACK® packages, depending on their level of environmental compliance. ECOPACK® specifications, grade definitions and product status are available at: www.st.com. ECOPACK® is an ST trademark.

Table 6. DPAK dimensions

| Ref. | Dimensions | | | |
|------|-------------|-------|------------|-------|
| | Millimeters | | Inches | |
| | Min. | Max. | Min. | Max. |
| A | 2.20 | 2.40 | 0.086 | 0.094 |
| A1 | 0.90 | 1.10 | 0.035 | 0.043 |
| A2 | 0.03 | 0.23 | 0.001 | 0.009 |
| B | 0.64 | 0.90 | 0.025 | 0.035 |
| B2 | 5.20 | 5.40 | 0.204 | 0.212 |
| C | 0.45 | 0.60 | 0.017 | 0.023 |
| C2 | 0.48 | 0.60 | 0.018 | 0.023 |
| D | 6.00 | 6.20 | 0.236 | 0.244 |
| E | 6.40 | 6.60 | 0.251 | 0.259 |
| G | 4.40 | 4.60 | 0.173 | 0.181 |
| H | 9.35 | 10.10 | 0.368 | 0.397 |
| L2 | 0.80 typ. | | 0.031 typ. | |
| L4 | 0.60 | 1.00 | 0.023 | 0.039 |
| V2 | 0° | 8° | 0° | 8° |

Figure 14. Footprint (dimensions in mm)

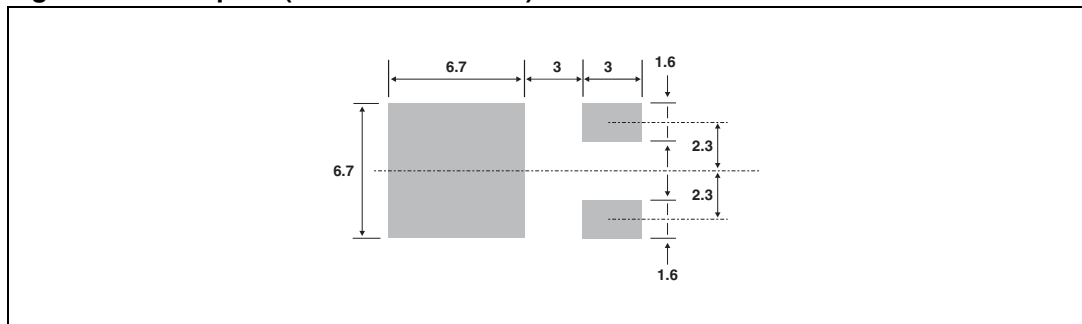
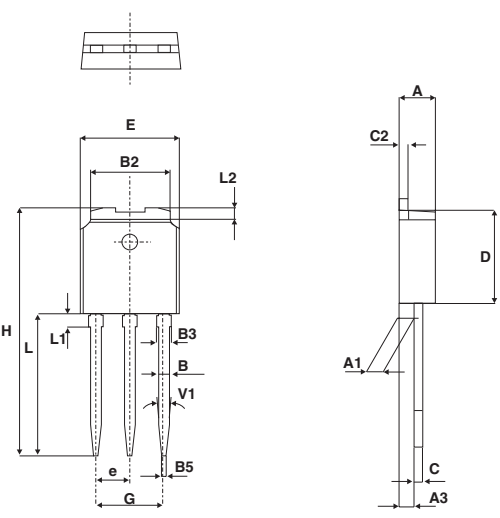
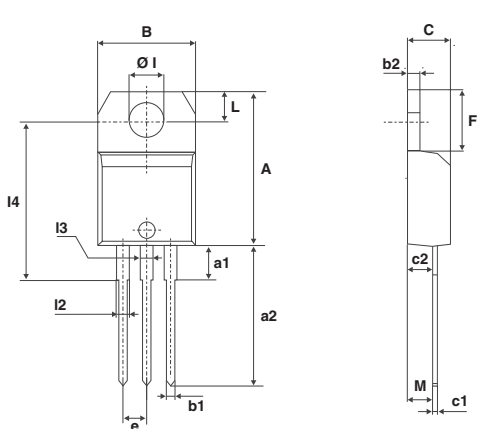

Table 7. IPAK dimensions



| Ref. | Dimensions | | | | | |
|------|-------------|-------|------|--------|-------|-------|
| | Millimeters | | | Inches | | |
| | Min. | Typ. | Max. | Min. | Typ. | Max. |
| A | 2.20 | | 2.40 | 0.086 | | 0.094 |
| A1 | 0.90 | | 1.10 | 0.035 | | 0.043 |
| A3 | 0.70 | | 1.30 | 0.027 | | 0.051 |
| B | 0.64 | | 0.90 | 0.025 | | 0.035 |
| B2 | 5.20 | | 5.40 | 0.204 | | 0.212 |
| B3 | | | 0.95 | | | 0.037 |
| B5 | | 0.30 | | | 0.035 | |
| C | 0.45 | | 0.60 | 0.017 | | 0.023 |
| C2 | 0.48 | | 0.60 | 0.019 | | 0.023 |
| D | 6 | | 6.20 | 0.236 | | 0.244 |
| E | 6.40 | | 6.60 | 0.252 | | 0.260 |
| e | | 2.28 | | | 0.090 | |
| G | 4.40 | | 4.60 | 0.173 | | 0.181 |
| H | | 16.10 | | | 0.634 | |
| L | 9 | | 9.40 | 0.354 | | 0.370 |
| L1 | 0.8 | | 1.20 | 0.031 | | 0.047 |
| L2 | | 0.80 | 1 | | 0.031 | 0.039 |
| V1 | | 10° | | | 10° | |

Table 8. TO-220AB dimensions



| Ref. | Dimensions | | | | | |
|------|-------------|-------|-------|--------|-------|-------|
| | Millimeters | | | Inches | | |
| | Min. | Typ. | Max. | Min. | Typ. | Max. |
| A | 15.20 | | 15.90 | 0.598 | | 0.625 |
| a1 | | 3.75 | | | 0.147 | |
| a2 | 13.00 | | 14.00 | 0.511 | | 0.551 |
| B | 10.00 | | 10.40 | 0.393 | | 0.409 |
| b1 | 0.61 | | 0.88 | 0.024 | | 0.034 |
| b2 | 1.23 | | 1.32 | 0.048 | | 0.051 |
| C | 4.40 | | 4.60 | 0.173 | | 0.181 |
| c1 | 0.49 | | 0.70 | 0.019 | | 0.027 |
| c2 | 2.40 | | 2.72 | 0.094 | | 0.107 |
| e | 2.40 | | 2.70 | 0.094 | | 0.106 |
| F | 6.20 | | 6.60 | 0.244 | | 0.259 |
| ØI | 3.75 | | 3.85 | 0.147 | | 0.151 |
| I4 | 15.80 | 16.40 | 16.80 | 0.622 | 0.646 | 0.661 |
| L | 2.65 | | 2.95 | 0.104 | | 0.116 |
| I2 | 1.14 | | 1.70 | 0.044 | | 0.066 |
| I3 | 1.14 | | 1.70 | 0.044 | | 0.066 |
| M | | 2.60 | | | 0.102 | |

4 Ordering information

Table 9. Ordering information

| Order code | Marking | Package | Weight | Base qty | Delivery mode |
|---------------|-----------|----------|--------|----------|---------------|
| TS420-600B | TS420600 | DPAK | 0.3 g | 75 | Tube |
| TS420-600B-TR | TS420600 | | | 2500 | Tape and reel |
| TS420-600H | TS420600 | IPAK | 0.4 g | 75 | Tube |
| TS420-600T | TS420600T | TO-220AB | 2.3 g | 50 | Tube |
| TS420-700B | TS420700 | DPAK | 0.3 g | 75 | Tube |
| TS420-700B-TR | TS420700 | | | 2500 | Tape and reel |
| TS420-700H | TS420700 | IPAK | 0.4 g | 75 | Tube |
| TS420-700T | TS420700T | TO-220AB | 2.3 g | 50 | Tube |

5 Revision history

Table 10. Document revision history

| Date | Revision | Changes |
|-------------|----------|---|
| Sep-2000 | 3 | Previous release. |
| 26-Jan-2010 | 4 | Updated package illustration for TO-220AB on front page and Table 8 . Added Table 3 . |

Please Read Carefully:

Information in this document is provided solely in connection with ST products. STMicroelectronics NV and its subsidiaries ("ST") reserve the right to make changes, corrections, modifications or improvements, to this document, and the products and services described herein at any time, without notice.

All ST products are sold pursuant to ST's terms and conditions of sale.

Purchasers are solely responsible for the choice, selection and use of the ST products and services described herein, and ST assumes no liability whatsoever relating to the choice, selection or use of the ST products and services described herein.

No license, express or implied, by estoppel or otherwise, to any intellectual property rights is granted under this document. If any part of this document refers to any third party products or services it shall not be deemed a license grant by ST for the use of such third party products or services, or any intellectual property contained therein or considered as a warranty covering the use in any manner whatsoever of such third party products or services or any intellectual property contained therein.

UNLESS OTHERWISE SET FORTH IN ST'S TERMS AND CONDITIONS OF SALE ST DISCLAIMS ANY EXPRESS OR IMPLIED WARRANTY WITH RESPECT TO THE USE AND/OR SALE OF ST PRODUCTS INCLUDING WITHOUT LIMITATION IMPLIED WARRANTIES OF MERCHANTABILITY, FITNESS FOR A PARTICULAR PURPOSE (AND THEIR EQUIVALENTS UNDER THE LAWS OF ANY JURISDICTION), OR INFRINGEMENT OF ANY PATENT, COPYRIGHT OR OTHER INTELLECTUAL PROPERTY RIGHT.

UNLESS EXPRESSLY APPROVED IN WRITING BY AN AUTHORIZED ST REPRESENTATIVE, ST PRODUCTS ARE NOT RECOMMENDED, AUTHORIZED OR WARRANTED FOR USE IN MILITARY, AIR CRAFT, SPACE, LIFE SAVING, OR LIFE SUSTAINING APPLICATIONS, NOR IN PRODUCTS OR SYSTEMS WHERE FAILURE OR MALFUNCTION MAY RESULT IN PERSONAL INJURY, DEATH, OR SEVERE PROPERTY OR ENVIRONMENTAL DAMAGE. ST PRODUCTS WHICH ARE NOT SPECIFIED AS "AUTOMOTIVE GRADE" MAY ONLY BE USED IN AUTOMOTIVE APPLICATIONS AT USER'S OWN RISK.

Resale of ST products with provisions different from the statements and/or technical features set forth in this document shall immediately void any warranty granted by ST for the ST product or service described herein and shall not create or extend in any manner whatsoever, any liability of ST.

ST and the ST logo are trademarks or registered trademarks of ST in various countries.

Information in this document supersedes and replaces all information previously supplied.

The ST logo is a registered trademark of STMicroelectronics. All other names are the property of their respective owners.

© 2010 STMicroelectronics - All rights reserved

STMicroelectronics group of companies

Australia - Belgium - Brazil - Canada - China - Czech Republic - Finland - France - Germany - Hong Kong - India - Israel - Italy - Japan - Malaysia - Malta - Morocco - Philippines - Singapore - Spain - Sweden - Switzerland - United Kingdom - United States of America

www.st.com