

RS-232 TRANSCEIVER WITH SPLIT SUPPLY PIN FOR LOGIC SIDE

FEATURES

- V_L Pin for Compatibility With Mixed-Voltage Systems Down to 1.8 V on Logic Side
- Enhanced ESD Protection on RIN Inputs and DOUT Outputs
 - ± 15 -kV Human-Body Model
 - ± 15 -kV IEC 61000-4-2, Air-Gap Discharge
 - ± 8 -kV IEC 61000-4-2, Contact Discharge
- Low 300- μ A Supply Current
- Specified 250-kbps Data Rate
- 1- μ A Low-Power Shutdown
- Meets EIA/TIA-232 Specifications Down to 3 V
- Designed to be Interchangeable With Industry Standard '3386 Devices

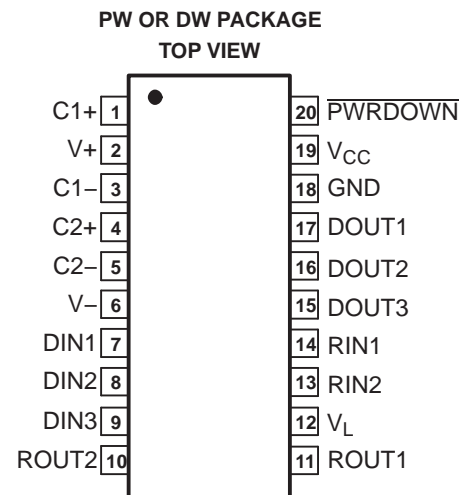

APPLICATIONS

- Hand-Held Equipment
- PDAs
- Cell Phones
- Battery-Powered Equipment
- Data Cables

DESCRIPTION/ORDERING INFORMATION

The TRS3386E is a three-driver and two-receiver RS-232 interface device, with split supply pins for mixed-signal operations. All RS-232 inputs and outputs are protected to ± 15 kV using the IEC 61000-4-2 Air-Gap Discharge method, ± 8 kV using the IEC 61000-4-2 Contact Discharge method, and ± 15 kV using the Human-Body Model.

The charge pump requires only four small 0.1- μ F capacitors for operation from a 3.3-V supply. The TRS3386E is capable of running at data rates up to 250 kbps, while maintaining RS-232-compliant output levels.

The TRS3386E has a unique V_L pin that allows operation in mixed-logic voltage systems. Both driver in (DIN) and receiver out (ROUT) logic levels are pin programmable through the V_L pin. The TRS3386E is available in a space-saving thin shrink small-outline package (TSSOP).

ORDERING INFORMATION

T _A	PACKAGE ⁽¹⁾⁽²⁾	ORDERABLE PART NUMBER	TOP-SIDE MARKING
0°C to 70°C	TSSOP – PW	TRS3386ECPWR	RV86EC
	SOIC – DW	TRS3386ECDWR	TRS3386EC
–40°C to 85°C	TSSOP – PW	TRS3386EIPWR	RV86EI
	SOIC – DW	TRS3386EIDWR	TRS3386EI

(1) Package drawings, thermal data, and symbolization are available at www.ti.com/packaging.

(2) For the most current package and ordering information, see the Package Option Addendum at the end of this document, or see the TI website at www.ti.com.



Please be aware that an important notice concerning availability, standard warranty, and use in critical applications of Texas Instruments semiconductor products and disclaimers thereto appears at the end of this data sheet.

TRUTH TABLE (SHUTDOWN FUNCTION)

PWRDWN	DRIVER OUTPUTS	RECEIVER OUTPUTS	CHARGE PUMP
L	High-Z	High-Z	Inactive
H	Active	Active	Active

FUNCTIONAL BLOCK DIAGRAM

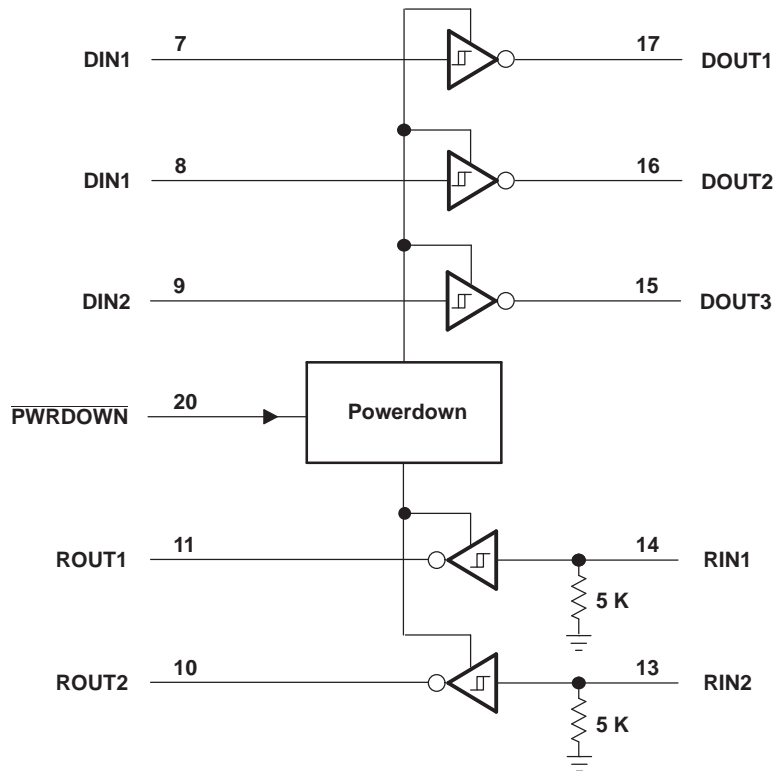

TERMINAL FUNCTIONS

TERMINAL		DESCRIPTION
NAME	NO.	
C1+	1	Positive terminal of the voltage-doubler charge-pump capacitor
V+	2	5.5-V supply generated by the charge pump
C1–	3	Negative terminal of the voltage-doubler charge-pump capacitor
C2+	4	Positive terminal of the inverting charge-pump capacitor
C2–	5	Negative terminal of the inverting charge-pump capacitor
V–	6	–5.5-V supply generated by the charge pump
DIN1 DIN2 DIN3	7 8 9	Driver inputs
ROUT2 ROUT1	10 11	Receiver outputs. Swing between 0 and V_L .
V_L	12	Logic-level supply. All CMOS inputs and outputs are referenced to this supply.
RIN2 RIN1	13 14	RS-232 receiver inputs
DOUT3 DOUT2 DOUT1	15 16 17	RS-232 driver outputs
GND	18	Ground
V_{CC}	19	3-V to 5.5-V supply voltage
\overline{PWRDWN}	20	Powerdown input L = Powerdown H = Normal operation

Absolute Maximum Ratings⁽¹⁾

over operating free-air temperature range (unless otherwise noted)

		MIN	MAX	UNIT
V_{CC} to GND		–0.3	6	V
V_L to GND		–0.3	$V_{CC} + 0.3$	V
V+ to GND		–0.3	7	V
V– to GND		0.3	–7	V
$V_+ + V_- ^{(2)}$			13	V
V_I	Input voltage	DIN, \overline{PWRDWN} to GND		V
		RIN to GND		
V_O	Output voltage	DOUT to GND		V
		ROUT		
Short-circuit duration DOUT to GND		Continuous		
Continuous power dissipation		$T_A = 70^\circ\text{C}$, 20-pin TSSOP (derate 7 mW/°C above 70°C)		mW
T_J	Junction temperature			150 °C
T_{stg}	Storage temperature range	–65		150 °C
Lead temperature (soldering, 10 s)				300 °C

- (1) Stresses beyond those listed under “absolute maximum ratings” may cause permanent damage to the device. These are stress ratings only, and functional operation of the device at these or any other conditions beyond those indicated in the operational sections of the specifications is not implied. Exposure to absolute maximum rating conditions for extended periods may affect device reliability.
- (2) V+ and V– can have maximum magnitudes of 7 V, but their absolute difference cannot exceed 13 V.

Recommended Operating Conditions

		MIN	MAX	UNIT
V_{CC}	Supply voltage	3	5.5	V
V_L	Supply voltage	1.65	V_{CC}	V
Input logic threshold low	DIN, \overline{PWRDWN}	$V_L = 3\text{ V or }5.5\text{ V}$	0.8	V
		$V_L = 2.3\text{ V}$	0.6	
		$V_L = 1.65\text{ V}$	0.5	
Input logic threshold high	DIN, \overline{PWRDWN}	$V_L = 5.5\text{ V}$	2.4	V
		$V_L = 3\text{ V}$	2.0	
		$V_L = 2.7\text{ V}$	1.4	
		$V_L = 1.95\text{ V}$	0.9	
Operating temperature	TRS3386ECPWR	0	70	°C
	TRS3386EIPWR	–40	85	
Receiver input voltage		–25	25	V

Electrical Characteristics

over operating free-air temperature range, $V_{CC} = V_L = 3\text{ V to }5.5\text{ V}$, $C1\text{--}C4 = 0.1\text{ }\mu\text{F}$ (tested at $3.3\text{ V} \pm 10\%$), $C1 = 0.047\text{ }\mu\text{F}$, $C2\text{--}C4 = 0.33\text{ }\mu\text{F}$ (tested at $5\text{ V} \pm 10\%$) (unless otherwise noted)

PARAMETER	TEST CONDITIONS	MIN	TYP ⁽¹⁾	MAX	UNIT
DC Characteristics ($V_{CC} = 3.3\text{ V or }5\text{ V}$, $T_A = 25^\circ\text{C}$)					
Powerdown supply current	$\overline{PWRDWN} = \text{GND}$, All inputs at V_{CC} or GND		1	10	μA
Supply current	$\overline{PWRDWN} = V_{CC}$, No load		0.3	1	mA

(1) Typical values are at $V_{CC} = V_L = 3.3\text{ V}$, $T_A = 25^\circ\text{C}$.

ESD Protection

PARAMETER	TEST CONDITIONS	TYP	UNIT
RIN, DOUT	Human-Body Model	± 15	kV
	IEC 61000-4-2 Air-Gap Discharge	± 15	
	IEC 61000-4-2 Contact Discharge	± 8	

RECEIVER SECTION

Electrical Characteristics

over operating free-air temperature range, $V_{CC} = V_L = 3\text{ V}$ to 5.5 V , $C1\text{--}C4 = 0.1\ \mu\text{F}$ (tested at $3.3\text{ V} \pm 10\%$), $C1 = 0.047\ \mu\text{F}$, $C2\text{--}C4 = 0.33\ \mu\text{F}$ (tested at $5\text{ V} \pm 10\%$), $T_A = T_{MIN}$ to T_{MAX} (unless otherwise noted)

PARAMETER		TEST CONDITIONS	MIN	TYP ⁽¹⁾	MAX	UNIT	
I_{off}	Output leakage current	ROUT, receivers disabled		±0.05	±10	μA	
V_{OL}	Output voltage low	$I_{OUT} = 1.6\text{ mA}$			0.4	V	
V_{OH}	Output voltage high	$I_{OUT} = -1\text{ mA}$	$V_L - 0.6$	$V_L - 0.1$		V	
V_{IT-}	Input threshold low	$T_A = 25^\circ\text{C}$	$V_L = 5\text{ V}$	0.8	1.2	V	
			$V_L = 3.3\text{ V}$	0.6	1.5		
V_{IT+}	Input threshold high	$T_A = 25^\circ\text{C}$	$V_L = 5\text{ V}$		1.8	2.4	V
			$V_L = 3.3\text{ V}$		1.5	2.4	
V_{hys}	Input hysteresis			0.5		V	
	Input resistance	$T_A = 25^\circ\text{C}$	3	5	7	kΩ	

(1) Typical values are at $V_{CC} = V_L = 3.3\text{ V}$, $T_A = 25^\circ\text{C}$

Switching Characteristics

over operating free-air temperature range, $V_{CC} = V_L = 3\text{ V}$ to 5.5 V , $C1\text{--}C4 = 0.1\ \mu\text{F}$ (tested at $3.3\text{ V} \pm 10\%$), $C1 = 0.047\ \mu\text{F}$, $C2\text{--}C4 = 0.33\ \mu\text{F}$ (tested at $5\text{ V} \pm 10\%$), $T_A = T_{MIN}$ to T_{MAX} (unless otherwise noted)

PARAMETER		TEST CONDITIONS	TYP ⁽¹⁾	UNIT
t_{PHL}	Receiver propagation delay	Receiver input to receiver output, $C_L = 150\text{ pF}$	0.15	μs
t_{PLH}			0.15	
$t_{PHL} - t_{PLH}$	Receiver skew		50	ns
t_{en}	Receiver output enable time	From $\overline{\text{PWRDWN}}$	200	ns
t_{dis}	Receiver output disable time	From $\overline{\text{PWRDWN}}$	200	ns

(1) Typical values are at $V_{CC} = V_L = 3.3\text{ V}$, $T_A = 25^\circ\text{C}$.

DRIVER SECTION

Electrical Characteristics

over operating free-air temperature range, $V_{CC} = V_L = 3\text{ V to }5.5\text{ V}$, $C1\text{--}C4 = 0.1\text{ }\mu\text{F}$ (tested at $3.3\text{ V} \pm 10\%$), $C1 = 0.047\text{ }\mu\text{F}$, $C2\text{--}C4 = 0.33\text{ }\mu\text{F}$ (tested at $5\text{ V} \pm 10\%$), $T_A = T_{MIN}$ to T_{MAX} (unless otherwise noted)

PARAMETER	TEST CONDITIONS	MIN	TYP ⁽¹⁾	MAX	UNIT
V_{OH} Output voltage swing	All driver outputs loaded with 3 k Ω to ground	± 5	± 5.4		V
r_O Output resistance	$V_{CC} = V_+ = V_- = 0$, Driver output = $\pm 2\text{ V}$	300	10M		Ω
I_{OS} Output short-circuit current	$V_{T_OUT} = 0$			± 60	mA
I_{OZ} Output leakage current	$V_{T_OUT} = \pm 12\text{ V}$, Driver disabled, $V_{CC} = 0$ or 3 V to 5.5 V			± 25	μA
Driver input hysteresis				0.5	V
Input leakage current	DIN, $\overline{\text{PWRDWN}}$		± 0.01	± 1	μA

(1) Typical values are at $V_{CC} = V_L = 3.3\text{ V}$, $T_A = 25^\circ\text{C}$

Timing Requirements

over operating free-air temperature range, $V_{CC} = V_L = 3\text{ V to }5.5\text{ V}$, $C1\text{--}C4 = 0.1\text{ }\mu\text{F}$ (tested at $3.3\text{ V} \pm 10\%$), $C1 = 0.047\text{ }\mu\text{F}$, $C2\text{--}C4 = 0.33\text{ }\mu\text{F}$ (tested at $5\text{ V} \pm 10\%$), $T_A = T_{MIN}$ to T_{MAX} (unless otherwise noted)

PARAMETER	TEST CONDITIONS	MIN	TYP ⁽¹⁾	MAX	UNIT
Maximum data rate	$R_L = 3\text{ k}\Omega$, $C_L = 1000\text{ pF}$, One driver switching	250			kbps
Time-to-exit powerdown	$ V_{T_OUT} > 3.7\text{ V}$		100		μs
$ t_{PHL} - t_{PLH} $ Driver skew ⁽²⁾			100		ns
Transition-region slew rate	$V_{CC} = 3.3\text{ V}$, $T_A = 25^\circ\text{C}$, $R_L = 3\text{ k}\Omega$ to 7 k Ω , Measured from 3 V to -3 V or -3 V to 3 V	$C_L = 150\text{ pF to }1000\text{ pF}$	6	30	V/ μs
		$C_L = 150\text{ pF to }2500\text{ pF}$	4	30	

(1) Typical values are at $V_{CC} = V_L = 3.3\text{ V}$, $T_A = 25^\circ\text{C}$.

(2) Driver skew is measured at the driver zero crosspoint.

ESD Protection

PARAMETER	TEST CONDITIONS	TYP	UNIT
RIN, DOUT	Human-Body Model	± 15	kV
	IEC 61000-4-2 Air-Gap Discharge	± 15	
	IEC 61000-4-2 Contact Discharge	± 8	

APPLICATION INFORMATION

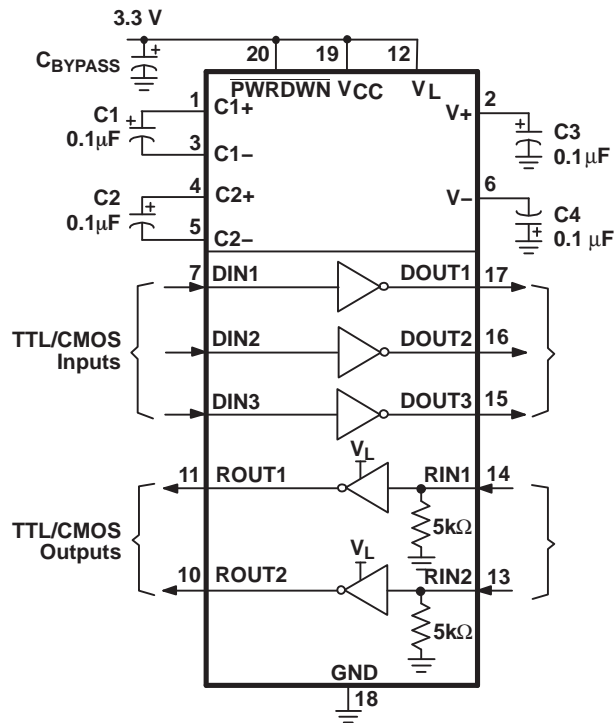

PARAMETER MEASUREMENT INFORMATION

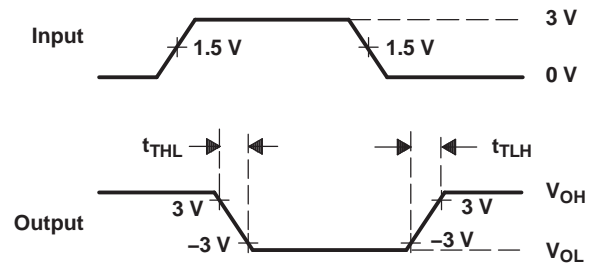
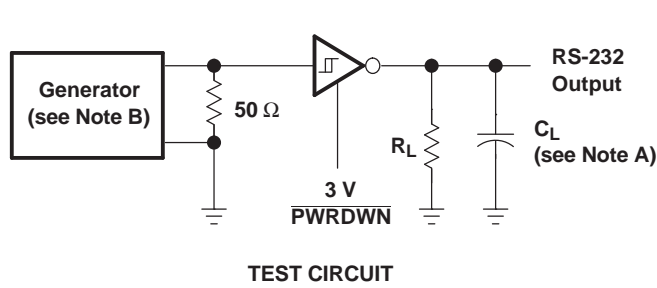

$$SR(tr) = \frac{6 V}{t_{THL} \text{ or } t_{TLH}}$$

- NOTES: A. C_L includes probe and jig capacitance.
 B. The pulse generator has the following characteristics: PRR = 250 kbit/s, $Z_O = 50 \Omega$, 50% duty cycle, $t_r \leq 10 \text{ ns}$, $t_f \leq 10 \text{ ns}$.

Figure 1. Driver Slew Rate

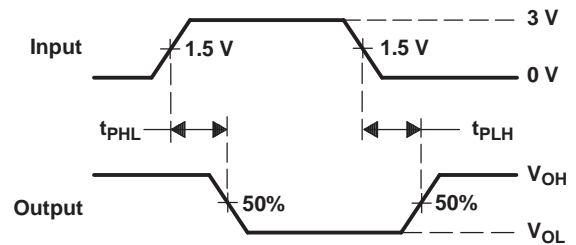
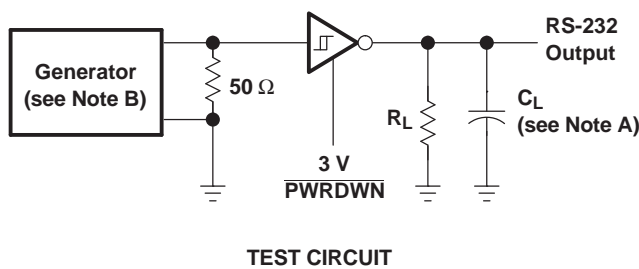

- NOTES: A. C_L includes probe and jig capacitance.
 B. The pulse generator has the following characteristics: PRR = 250 kbit/s, $Z_O = 50 \Omega$, 50% duty cycle, $t_r \leq 10 \text{ ns}$, $t_f \leq 10 \text{ ns}$.

Figure 2. Driver Pulse Skew

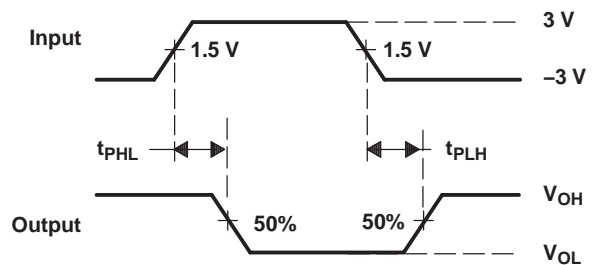
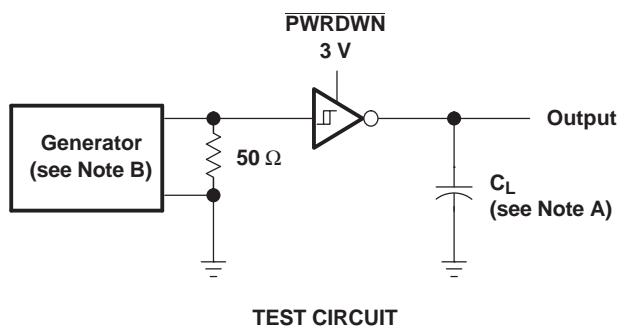

- NOTES: A. C_L includes probe and jig capacitance.
 B. The pulse generator has the following characteristics: $Z_O = 50 \Omega$, 50% duty cycle, $t_r \leq 10 \text{ ns}$, $t_f \leq 10 \text{ ns}$.

Figure 3. Receiver Propagation Delay Times

PARAMETER MEASUREMENT INFORMATION (Continued)

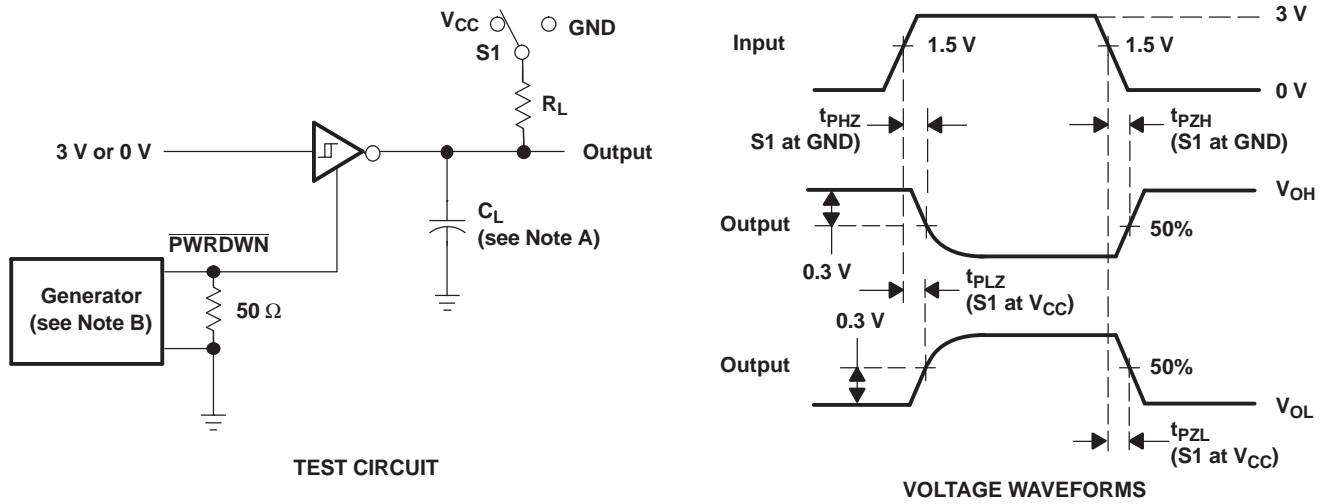

- NOTES: A. C_L includes probe and jig capacitance.
 B. The pulse generator has the following characteristics: $Z_O = 50 \Omega$, 50% duty cycle, $t_r \leq 10 \text{ ns}$, $t_f \leq 10 \text{ ns}$.

Figure 4. Receiver Enable and Disable Times

PACKAGING INFORMATION

Orderable Device	Status ⁽¹⁾	Package Type	Package Drawing	Pins	Package Qty	Eco Plan ⁽²⁾	Lead/Ball Finish	MSL Peak Temp ⁽³⁾
TRS3386ECDW	ACTIVE	SOIC	DW	20	25	Green (RoHS & no Sb/Br)	CU NIPDAU	Level-1-260C-UNLIM
TRS3386ECDWG4	ACTIVE	SOIC	DW	20	25	Green (RoHS & no Sb/Br)	CU NIPDAU	Level-1-260C-UNLIM
TRS3386ECDWR	ACTIVE	SOIC	DW	20	2000	Green (RoHS & no Sb/Br)	CU NIPDAU	Level-1-260C-UNLIM
TRS3386ECDWRG4	ACTIVE	SOIC	DW	20	2000	Green (RoHS & no Sb/Br)	CU NIPDAU	Level-1-260C-UNLIM
TRS3386ECPW	ACTIVE	TSSOP	PW	20	70	Green (RoHS & no Sb/Br)	CU NIPDAU	Level-1-260C-UNLIM
TRS3386ECPWG4	ACTIVE	TSSOP	PW	20	70	Green (RoHS & no Sb/Br)	CU NIPDAU	Level-1-260C-UNLIM
TRS3386ECPWR	ACTIVE	TSSOP	PW	20	2000	Green (RoHS & no Sb/Br)	CU NIPDAU	Level-1-260C-UNLIM
TRS3386ECPWRG4	ACTIVE	TSSOP	PW	20	2000	Green (RoHS & no Sb/Br)	CU NIPDAU	Level-1-260C-UNLIM
TRS3386EIDW	ACTIVE	SOIC	DW	20	25	Green (RoHS & no Sb/Br)	CU NIPDAU	Level-1-260C-UNLIM
TRS3386EIDWG4	ACTIVE	SOIC	DW	20	25	Green (RoHS & no Sb/Br)	CU NIPDAU	Level-1-260C-UNLIM
TRS3386EIDWR	ACTIVE	SOIC	DW	20	2000	Green (RoHS & no Sb/Br)	CU NIPDAU	Level-1-260C-UNLIM
TRS3386EIDWRG4	ACTIVE	SOIC	DW	20	2000	Green (RoHS & no Sb/Br)	CU NIPDAU	Level-1-260C-UNLIM
TRS3386EIPW	ACTIVE	TSSOP	PW	20	70	Green (RoHS & no Sb/Br)	CU NIPDAU	Level-1-260C-UNLIM
TRS3386EIPWG4	ACTIVE	TSSOP	PW	20	70	Green (RoHS & no Sb/Br)	CU NIPDAU	Level-1-260C-UNLIM
TRS3386EIPWR	ACTIVE	TSSOP	PW	20	2000	Green (RoHS & no Sb/Br)	CU NIPDAU	Level-1-260C-UNLIM
TRS3386EIPWRG4	ACTIVE	TSSOP	PW	20	2000	Green (RoHS & no Sb/Br)	CU NIPDAU	Level-1-260C-UNLIM

⁽¹⁾ The marketing status values are defined as follows:

ACTIVE: Product device recommended for new designs.

LIFEBUY: TI has announced that the device will be discontinued, and a lifetime-buy period is in effect.

NRND: Not recommended for new designs. Device is in production to support existing customers, but TI does not recommend using this part in a new design.

PREVIEW: Device has been announced but is not in production. Samples may or may not be available.

OBSOLETE: TI has discontinued the production of the device.

⁽²⁾ Eco Plan - The planned eco-friendly classification: Pb-Free (RoHS), Pb-Free (RoHS Exempt), or Green (RoHS & no Sb/Br) - please check <http://www.ti.com/productcontent> for the latest availability information and additional product content details.

TBD: The Pb-Free/Green conversion plan has not been defined.

Pb-Free (RoHS): TI's terms "Lead-Free" or "Pb-Free" mean semiconductor products that are compatible with the current RoHS requirements for all 6 substances, including the requirement that lead not exceed 0.1% by weight in homogeneous materials. Where designed to be soldered at high temperatures, TI Pb-Free products are suitable for use in specified lead-free processes.

Pb-Free (RoHS Exempt): This component has a RoHS exemption for either 1) lead-based flip-chip solder bumps used between the die and package, or 2) lead-based die adhesive used between the die and leadframe. The component is otherwise considered Pb-Free (RoHS compatible) as defined above.

Green (RoHS & no Sb/Br): TI defines "Green" to mean Pb-Free (RoHS compatible), and free of Bromine (Br) and Antimony (Sb) based flame retardants (Br or Sb do not exceed 0.1% by weight in homogeneous material)

⁽³⁾ MSL, Peak Temp. -- The Moisture Sensitivity Level rating according to the JEDEC industry standard classifications, and peak solder temperature.

Important Information and Disclaimer:The information provided on this page represents TI's knowledge and belief as of the date that it is provided. TI bases its knowledge and belief on information provided by third parties, and makes no representation or warranty as to the accuracy of such information. Efforts are underway to better integrate information from third parties. TI has taken and continues to take reasonable steps to provide representative and accurate information but may not have conducted destructive testing or chemical analysis on incoming materials and chemicals. TI and TI suppliers consider certain information to be proprietary, and thus CAS numbers and other limited information may not be available for release.

In no event shall TI's liability arising out of such information exceed the total purchase price of the TI part(s) at issue in this document sold by TI to Customer on an annual basis.

TAPE AND REEL INFORMATION

QUADRANT ASSIGNMENTS FOR PIN 1 ORIENTATION IN TAPE

*All dimensions are nominal

Device	Package Type	Package Drawing	Pins	SPQ	Reel Diameter (mm)	Reel Width W1 (mm)	A0 (mm)	B0 (mm)	K0 (mm)	P1 (mm)	W (mm)	Pin1 Quadrant
TRS3386ECDWR	SOIC	DW	20	2000	330.0	24.4	10.8	13.0	2.7	12.0	24.0	Q1
TRS3386ECPWR	TSSOP	PW	20	2000	330.0	16.4	6.95	7.1	1.6	8.0	16.0	Q1
TRS3386EIDWR	SOIC	DW	20	2000	330.0	24.4	10.8	13.0	2.7	12.0	24.0	Q1
TRS3386EIPWR	TSSOP	PW	20	2000	330.0	16.4	6.95	7.1	1.6	8.0	16.0	Q1

TAPE AND REEL BOX DIMENSIONS

*All dimensions are nominal

Device	Package Type	Package Drawing	Pins	SPQ	Length (mm)	Width (mm)	Height (mm)
TRS3386ECDWR	SOIC	DW	20	2000	346.0	346.0	41.0
TRS3386ECPWR	TSSOP	PW	20	2000	346.0	346.0	33.0
TRS3386EIDWR	SOIC	DW	20	2000	346.0	346.0	41.0
TRS3386EIPWR	TSSOP	PW	20	2000	346.0	346.0	33.0

DW (R-PDSO-G20)

PLASTIC SMALL-OUTLINE PACKAGE



- NOTES:
- A. All linear dimensions are in inches (millimeters).
 - B. This drawing is subject to change without notice.
 - C. Body dimensions do not include mold flash or protrusion not to exceed 0.006 (0,15).
 - D. Falls within JEDEC MS-013 variation AC.

PW (R-PDSO-G**)

PLASTIC SMALL-OUTLINE PACKAGE

14 PINS SHOWN



4040064/F 01/97

- NOTES: A. All linear dimensions are in millimeters.
 B. This drawing is subject to change without notice.
 C. Body dimensions do not include mold flash or protrusion not to exceed 0,15.
 D. Falls within JEDEC MO-153

IMPORTANT NOTICE

Texas Instruments Incorporated and its subsidiaries (TI) reserve the right to make corrections, modifications, enhancements, improvements, and other changes to its products and services at any time and to discontinue any product or service without notice. Customers should obtain the latest relevant information before placing orders and should verify that such information is current and complete. All products are sold subject to TI's terms and conditions of sale supplied at the time of order acknowledgment.

TI warrants performance of its hardware products to the specifications applicable at the time of sale in accordance with TI's standard warranty. Testing and other quality control techniques are used to the extent TI deems necessary to support this warranty. Except where mandated by government requirements, testing of all parameters of each product is not necessarily performed.

TI assumes no liability for applications assistance or customer product design. Customers are responsible for their products and applications using TI components. To minimize the risks associated with customer products and applications, customers should provide adequate design and operating safeguards.

TI does not warrant or represent that any license, either express or implied, is granted under any TI patent right, copyright, mask work right, or other TI intellectual property right relating to any combination, machine, or process in which TI products or services are used. Information published by TI regarding third-party products or services does not constitute a license from TI to use such products or services or a warranty or endorsement thereof. Use of such information may require a license from a third party under the patents or other intellectual property of the third party, or a license from TI under the patents or other intellectual property of TI.

Reproduction of TI information in TI data books or data sheets is permissible only if reproduction is without alteration and is accompanied by all associated warranties, conditions, limitations, and notices. Reproduction of this information with alteration is an unfair and deceptive business practice. TI is not responsible or liable for such altered documentation. Information of third parties may be subject to additional restrictions.

Resale of TI products or services with statements different from or beyond the parameters stated by TI for that product or service voids all express and any implied warranties for the associated TI product or service and is an unfair and deceptive business practice. TI is not responsible or liable for any such statements.

TI products are not authorized for use in safety-critical applications (such as life support) where a failure of the TI product would reasonably be expected to cause severe personal injury or death, unless officers of the parties have executed an agreement specifically governing such use. Buyers represent that they have all necessary expertise in the safety and regulatory ramifications of their applications, and acknowledge and agree that they are solely responsible for all legal, regulatory and safety-related requirements concerning their products and any use of TI products in such safety-critical applications, notwithstanding any applications-related information or support that may be provided by TI. Further, Buyers must fully indemnify TI and its representatives against any damages arising out of the use of TI products in such safety-critical applications.

TI products are neither designed nor intended for use in military/aerospace applications or environments unless the TI products are specifically designated by TI as military-grade or "enhanced plastic." Only products designated by TI as military-grade meet military specifications. Buyers acknowledge and agree that any such use of TI products which TI has not designated as military-grade is solely at the Buyer's risk, and that they are solely responsible for compliance with all legal and regulatory requirements in connection with such use.

TI products are neither designed nor intended for use in automotive applications or environments unless the specific TI products are designated by TI as compliant with ISO/TS 16949 requirements. Buyers acknowledge and agree that, if they use any non-designated products in automotive applications, TI will not be responsible for any failure to meet such requirements.

Following are URLs where you can obtain information on other Texas Instruments products and application solutions:

Products		Applications	
Amplifiers	amplifier.ti.com	Audio	www.ti.com/audio
Data Converters	dataconverter.ti.com	Automotive	www.ti.com/automotive
DLP® Products	www.dlp.com	Communications and Telecom	www.ti.com/communications
DSP	dsp.ti.com	Computers and Peripherals	www.ti.com/computers
Clocks and Timers	www.ti.com/clocks	Consumer Electronics	www.ti.com/consumer-apps
Interface	interface.ti.com	Energy	www.ti.com/energy
Logic	logic.ti.com	Industrial	www.ti.com/industrial
Power Mgmt	power.ti.com	Medical	www.ti.com/medical
Microcontrollers	microcontroller.ti.com	Security	www.ti.com/security
RFID	www.ti-rfid.com	Space, Avionics & Defense	www.ti.com/space-avionics-defense
RF/IF and ZigBee® Solutions	www.ti.com/lprf	Video and Imaging	www.ti.com/video
		Wireless	www.ti.com/wireless-apps