

TPS7A65xx-Q1 300-mA, 40-V, Low-Dropout Regulator With 25- μ A Quiescent Current

1 Features

- Low Dropout Voltage
 - 300 mV at $I_{OUT} = 150$ mA
- 4-V to 40-V Wide Input Voltage Range With up to 45-V Transients
- 300-mA Maximum Output Current
- 25- μ A (Typical) Ultralow Quiescent Current at Light Loads
- 3.3-V and 5-V Fixed Output Voltage With $\pm 2\%$ Tolerance
- Low-ESR Ceramic Output Stability Capacitor
- Integrated Fault Protection
 - Short-Circuit and Overcurrent Protection
 - Thermal Shutdown
- Low Input-Voltage Tracking
- Thermally Enhanced Power Package
 - 3-Pin TO-252 (KVU/DPAK)

2 Applications

- Qualified for Automotive Applications
- Infotainment Systems With Sleep Mode
- Body Control Modules
- Always-On Battery Applications
 - Gateway Applications
 - Remote Keyless Entry Systems
 - Immobilizers

3 Description

The TPS7A65xx-Q1 is a family of low-dropout linear voltage regulators designed for low power consumption and quiescent current less than 25 μ A in light-load applications. These devices feature integrated overcurrent protection and a design to achieve stable operation even with low-ESR ceramic output capacitors. A low-voltage tracking feature allows for a smaller input capacitor and can possibly eliminate the need of using a boost converter during cold crank conditions. Because of these features, these devices are well-suited in power supplies for various automotive applications.

Device Information⁽¹⁾

| PART NUMBER | PACKAGE | BODY SIZE (NOM) |
|--------------|------------|-------------------|
| TPS7A6533-Q1 | TO-252 (3) | 6.60 mm x 6.10 mm |
| TPS7A6550-Q1 | | |

(1) For all available packages, see the package option addendum at the end of the data sheet.

Typical Application Schematic

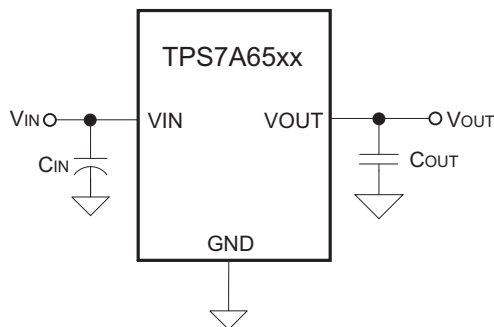

Typical Regulator Stability

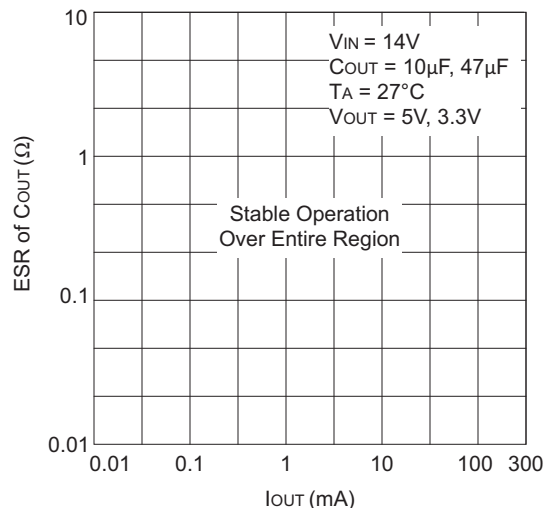

Table of Contents

| | | | |
|--|----------|--|-----------|
| 1 Features | 1 | 7.4 Device Functional Modes..... | 12 |
| 2 Applications | 1 | 8 Application and Implementation | 13 |
| 3 Description | 1 | 8.1 Application Information..... | 13 |
| 4 Revision History | 2 | 8.2 Typical Application | 13 |
| 5 Pin Configuration and Functions | 3 | 9 Power Supply Recommendations | 15 |
| 6 Specifications | 4 | 10 Layout | 15 |
| 6.1 Absolute Maximum Ratings | 4 | 10.1 Layout Guidelines | 15 |
| 6.2 ESD Ratings..... | 4 | 10.2 Layout Example | 15 |
| 6.3 Recommended Operating Conditions..... | 4 | 10.3 Power Dissipation and Thermal Considerations... | 15 |
| 6.4 Thermal Information | 4 | 11 Device and Documentation Support | 18 |
| 6.5 Electrical Characteristics..... | 5 | 11.1 Related Links | 18 |
| 6.6 Dissipation Ratings | 5 | 11.2 Community Resources..... | 18 |
| 6.7 Typical Characteristics | 6 | 11.3 Trademarks | 18 |
| 7 Detailed Description | 9 | 11.4 Electrostatic Discharge Caution..... | 18 |
| 7.1 Overview | 9 | 11.5 Glossary | 18 |
| 7.2 Functional Block Diagram | 9 | 12 Mechanical, Packaging, and Orderable Information | 18 |
| 7.3 Feature Description..... | 9 | | |

4 Revision History

NOTE: Page numbers for previous revisions may differ from page numbers in the current version.

| Changes from Revision C (December 2011) to Revision D | Page |
|---|-------------|
| <ul style="list-style-type: none"> Added <i>Pin Configuration and Functions</i> section, <i>ESD Ratings</i> table, <i>Feature Description</i> section, <i>Device Functional Modes</i> section, <i>Application and Implementation</i> section, <i>Power Supply Recommendations</i> section, <i>Layout</i> section, <i>Device and Documentation Support</i> section, and <i>Mechanical, Packaging, and Orderable Information</i> section | 1 |

| Changes from Revision B (November 2011) to Revision C | Page |
|---|----------------------|
| <ul style="list-style-type: none"> Deleted the TPS7A6533QKVURQ1 device..... Changed the Regulated Output Voltage (5.1). Added to Test Conditions "10mA to 300mA, $V_{IN} = V_{OUT} + 1V$ to 16V" | 1 5 |

| Changes from Revision A (November 2011) to Revision B | Page |
|--|-------------|
| <ul style="list-style-type: none"> Changed the θ_{JP} value in the Abs Max Table From: 12.7 To: 1.2°C/W | 4 |

| Changes from Original (May 2010) to Revision A | Page |
|--|-------------|
| <ul style="list-style-type: none"> Removed all KKT information..... | 4 |

5 Pin Configuration and Functions

**KVU Package
3-Pin TO-252
Top View**

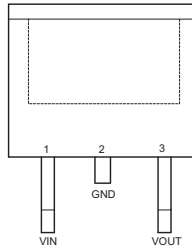

Pin Functions

| PIN | | I/O | DESCRIPTION |
|-----|------|-----|---|
| NO. | NAME | | |
| 1 | VIN | I | Input voltage pin: The unregulated input voltage is supplied to this pin. A bypass capacitor is connected between VIN pin and GND pin to dampen input line transients. |
| 2 | GND | I/O | Ground pin: This is signal ground pin of the IC. |
| 3 | VOUT | O | Regulated output voltage pin: This is a regulated voltage output ($V_{OUT} = 3.3\text{ V}$ or 5 V , as applicable) pin with a limitation on maximum output current. To achieve stable operation and prevent oscillation, an external output capacitor (C_{OUT}) with low ESR is connected between this pin and the GND pin. |

6 Specifications

6.1 Absolute Maximum Ratings

over operating free-air temperature range (unless otherwise noted)⁽¹⁾

| | MIN | MAX | UNIT |
|---|-----|-----|------|
| V _{IN} Unregulated input ⁽²⁾⁽³⁾ | | 45 | V |
| V _{OUT} Regulated output | | 7 | V |
| θ _{JP} Thermal impedance junction to exposed pad | | 1.2 | °C/W |
| T _A Operating ambient temperature | | 125 | °C |
| T _{stg} Storage temperature | -65 | 150 | °C |

- (1) Stresses beyond those listed under *Absolute Maximum Ratings* may cause permanent damage to the device. These are stress ratings only, which do not imply functional operation of the device at these or any other conditions beyond those indicated under *Recommended Operating Conditions*. Exposure to absolute-maximum-rated conditions for extended periods may affect device reliability.
- (2) Absolute negative voltage on these pins not to go below -0.3 V.
- (3) Absolute maximum voltage for duration less than 480 ms.

6.2 ESD Ratings

| | VALUE | UNIT |
|--|-------|------|
| V _(ESD) Electrostatic discharge Human body model (HBM), per AEC Q100-002 ⁽¹⁾ | ±2000 | V |

- (1) AEC Q100-002 indicates HBM stressing is done in accordance with the ANSI/ESDA/JEDEC JS-001 specification.

6.3 Recommended Operating Conditions

| | MIN | MAX | UNIT |
|---|-----|-----|------|
| V _{IN} Unregulated input voltage | 4 | 40 | V |
| T _J Operating junction temperature | -40 | 150 | °C |

6.4 Thermal Information

| THERMAL METRIC ⁽¹⁾ | | TPS7A65xx-Q1 | UNIT |
|--|-------------------------------|--------------|------|
| | | KVU (TO-252) | |
| | | 3 PINS | |
| R _{θJA} Junction-to-ambient thermal resistance | High-K profile ⁽²⁾ | 29.3 | °C/W |
| | Low-K profile ⁽³⁾ | 38.6 | °C/W |
| R _{θJC(top)} Junction-to-case (top) thermal resistance | | N/A | °C/W |
| R _{θJB} Junction-to-board thermal resistance | | 8.2 | °C/W |
| ψ _{JT} Junction-to-top characterization parameter | | 3.4 | °C/W |
| ψ _{JB} Junction-to-board characterization parameter | | 8.1 | °C/W |
| R _{θJC(bot)} Junction-to-case (bottom) thermal resistance | | 1.1 | °C/W |

- (1) For more information about traditional and new thermal metrics, see the *Semiconductor and IC Package Thermal Metrics* application report, [SPRA953](#).
- (2) The thermal data is based on JEDEC standard high-K profile – JESD 51-5. The copper pad is soldered to the thermal land pattern. Also correct attachment procedure must be incorporated.
- (3) The thermal data is based on JEDEC standard low-K profile – JESD 51-3. The copper pad is soldered to the thermal land pattern. Also correct attachment procedure must be incorporated.

6.5 Electrical Characteristics

 $V_{IN} = 14V$, $T_J = -40^{\circ}C$ to $+150^{\circ}C$ (unless otherwise noted)

| PARAMETER | TEST CONDITIONS | MIN | TYP | MAX | UNIT | |
|--|---|--|-----|------|------|---------------|
| INPUT VOLTAGE (VIN PIN) | | | | | | |
| V_{IN} | Input voltage | Fixed 5-V output, $I_{OUT} = 1\text{ mA}$ | | 5.3 | 40 | V |
| | | Fixed 3.3-V output, $I_{OUT} = 1\text{ mA}$ | | 3.6 | 40 | |
| $I_{QUIESCENT}$ | Quiescent current | $V_{IN} = 8.2\text{ V to }18\text{ V}$, $I_{OUT} = 0.01\text{ mA to }0.75\text{ mA}$ | | 25 | 40 | μA |
| $V_{IN-UVLO}$ | Undervoltage lockout voltage | Ramp V_{IN} down until output is turned OFF | | 3.16 | | V |
| $V_{IN(POWERUP)}$ | Power-up voltage | Ramp V_{IN} up until output is turned ON | | 3.45 | | V |
| REGULATED OUTPUT VOLTAGE (VOUT PIN) | | | | | | |
| V_{OUT} | Regulated output voltage | Fixed V_{OUT} value (3.3 V or 5 V as applicable), $I_{OUT} = 10\text{ mA}$, 10 mA to 300 mA, $V_{IN} = V_{OUT} + 1\text{ V to }16\text{ V}$ | | -2% | 2% | |
| $\Delta V_{LINE-REG}$ | Line regulation | $V_{IN} = 6\text{ V to }28\text{ V}$, $I_{OUT} = 10\text{ mA}$, $V_{OUT} = 5\text{ V}$ | | 15 | | mV |
| | | $V_{IN} = 6\text{ V to }28\text{ V}$, $I_{OUT} = 10\text{ mA}$, $V_{OUT} = 3.3\text{ V}$ | | 20 | | |
| $\Delta V_{LOAD-REG}$ | Load regulation | $I_{OUT} = 10\text{ mA to }300\text{ mA}$, $V_{IN} = 14\text{ V}$, $V_{OUT} = 5\text{ V}$ | | 25 | | mV |
| | | $I_{OUT} = 10\text{ mA to }300\text{ mA}$, $V_{IN} = 14\text{ V}$, $V_{OUT} = 3.3\text{ V}$ | | 35 | | |
| $V_{DROPOUT}^{(1)}$ | Dropout voltage ($V_{IN} - V_{OUT}$) | $I_{OUT} = 250\text{ mA}$ | | 500 | | mV |
| | | $I_{OUT} = 150\text{ mA}$ | | 300 | | |
| $R_{SW}^{(2)}$ | Switch resistance | VIN to VOUT resistance | | 2 | | Ω |
| I_{OUT} | Output current | V_{OUT} in regulation | | 0 | 300 | mA |
| I_{CL} | Output current limit | $V_{OUT} = 0\text{ V}$ (V_{OUT} pin is shorted to ground) | | 350 | 1000 | mA |
| $PSRR^{(2)}$ | Power-supply ripple rejection | $V_{IN-RIPPLE} = 0.5\text{ V}_{pp}$, $I_{OUT} = 300\text{ mA}$, frequency = 100 Hz, $V_{OUT} = 5\text{ V}$, $V_{OUT} = 3.3\text{ V}$ | | 60 | | dB |
| | | $V_{IN-RIPPLE} = 0.5\text{ V}_{pp}$, $I_{OUT} = 300\text{ mA}$, frequency = 150 kHz, $V_{OUT} = 5\text{ V}$, $V_{OUT} = 3.3\text{ V}$ | | 30 | | |
| TEMPERATURE | | | | | | |
| $T_{SHUTDOWN}$ | Thermal shutdown trip point | | 165 | | | $^{\circ}C$ |
| T_{HYST} | Thermal shutdown hysteresis | | 10 | | | $^{\circ}C$ |

(1) This test is done with V_{OUT} in regulation and $V_{IN} - V_{OUT}$ parameter is measured when V_{OUT} (3.3 V or 5 V) drops by 100 mV at specified loads.

(2) Specified by design; not tested.

6.6 Dissipation Ratings

| JEDEC STANDARD | PACKAGE | $T_A < 25^{\circ}C$ POWER RATING (W) | DERATING FACTOR ABOVE $T_A = 25^{\circ}C$ ($^{\circ}C/W$) | $T_A = 85^{\circ}C$ POWER RATING (W) |
|--|------------|--------------------------------------|---|--------------------------------------|
| JEDEC Standard PCB - low K, JESD 51-3 | 3-pin KVVU | 3.24 | 38.6 | 1.68 |
| JEDEC Standard PCB - high K, JESD 51-5 | 3-pin KVVU | 4.27 | 29.3 | 2.22 |

6.7 Typical Characteristics

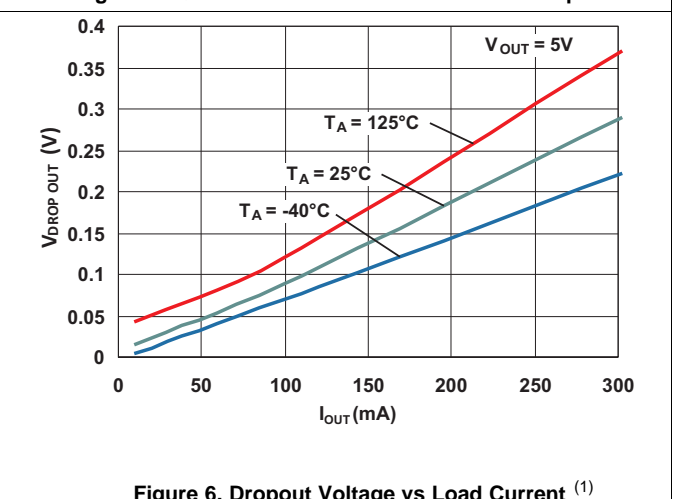
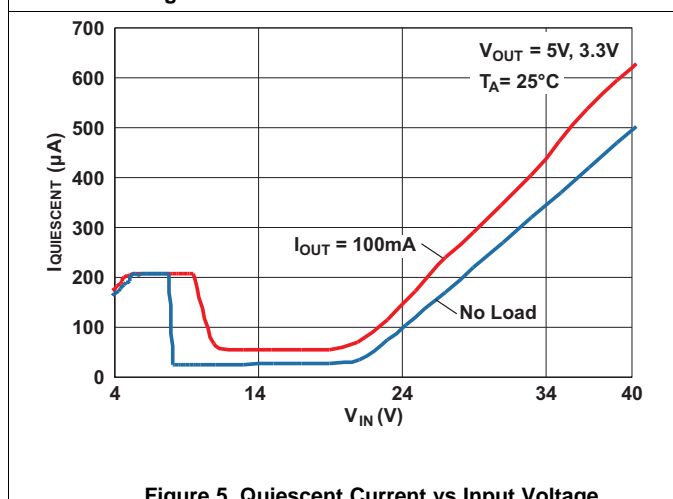
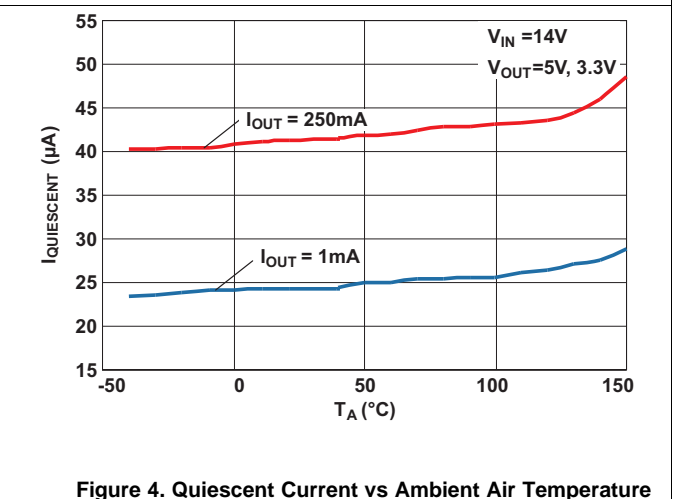
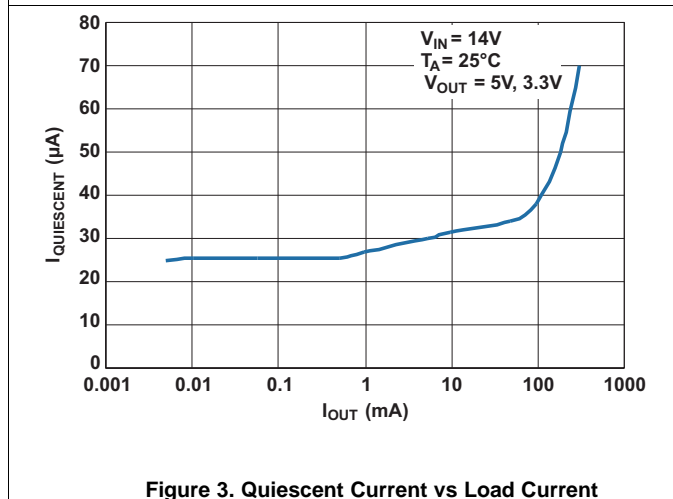
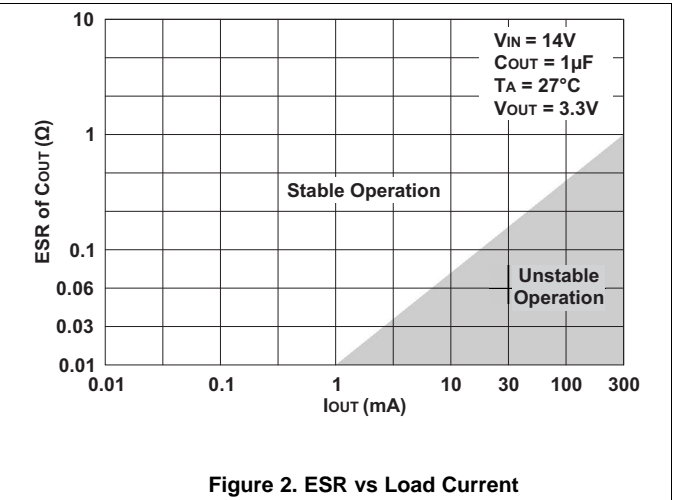
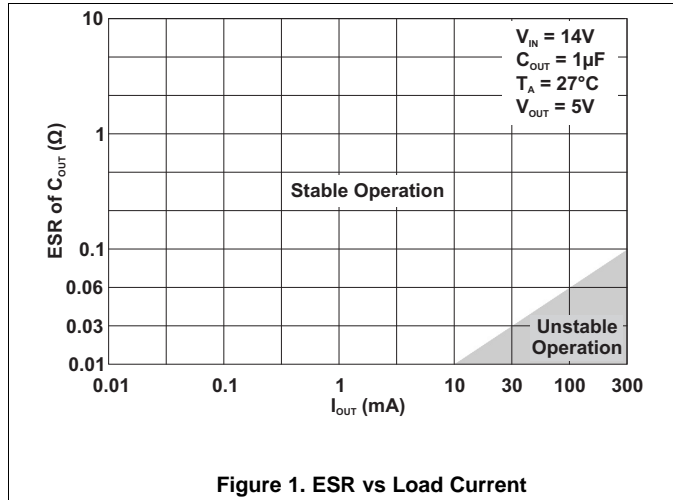

(1) Dropout voltage is measured when the output voltage drops by 100 mV from the regulated output voltage level. (For example, the drop out voltage for TPS7A6550 is measured when the output voltage drops down to 4.9 V from 5 V.)

Typical Characteristics (continued)

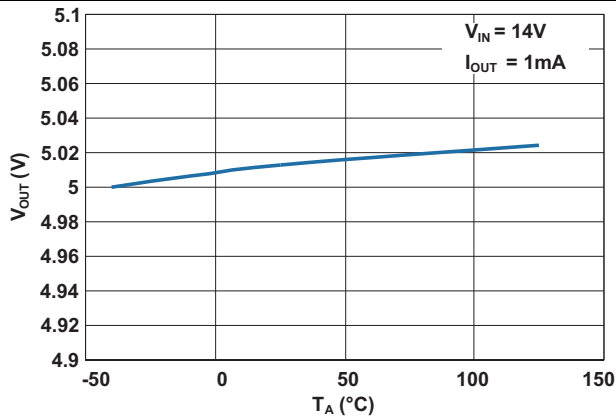

Figure 7. Output Voltage vs Ambient Air Temperature

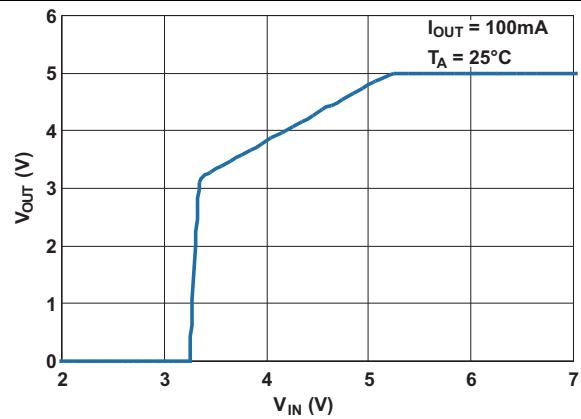

Figure 8. Output Voltage vs Input Voltage

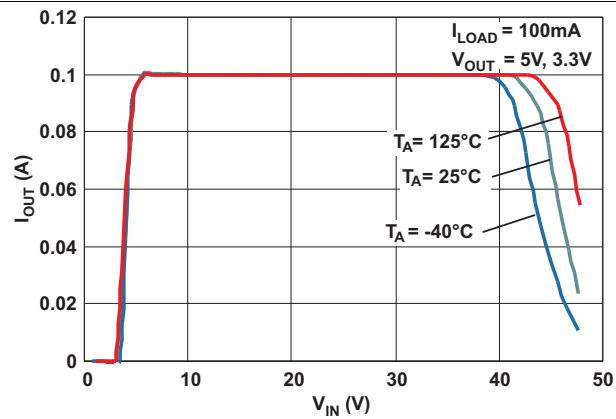

Figure 9. Output Current vs Input Voltage

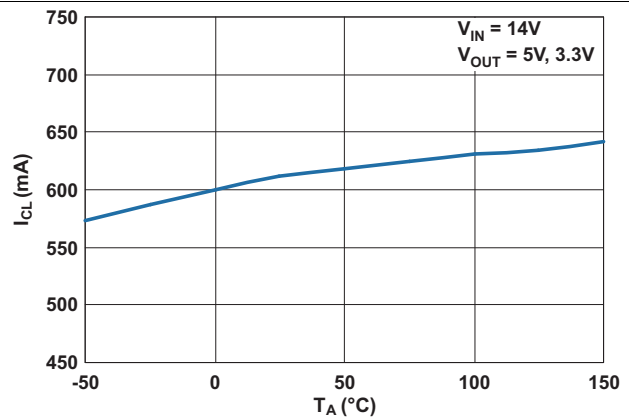

Figure 10. Output Current Limit vs Ambient Air Temperature

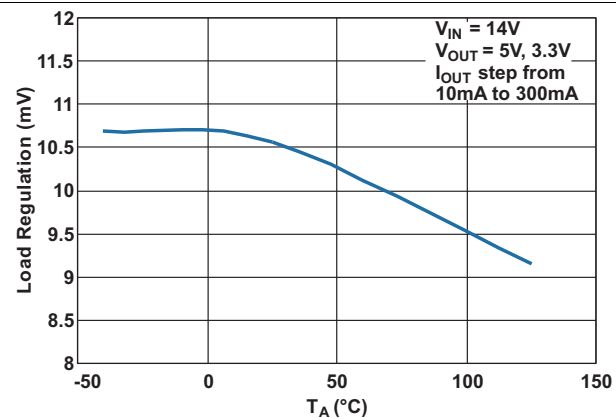

Figure 11. Load Regulation vs Ambient Air Temperature

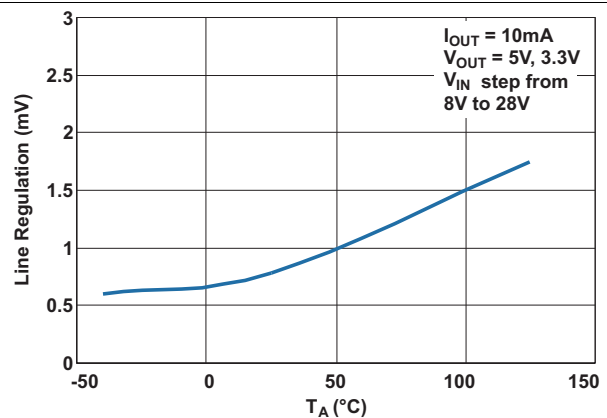
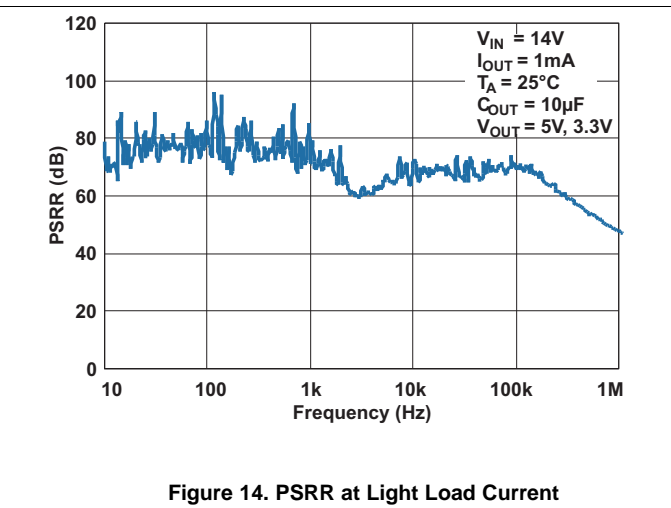
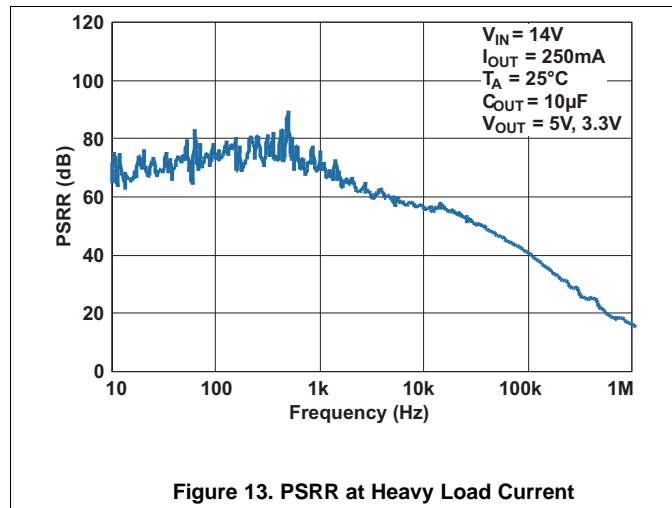

Figure 12. Line Regulation vs Ambient Air Temperature

Typical Characteristics (continued)

7 Detailed Description

7.1 Overview

TPS7A65xx-Q1 is a family of monolithic low-dropout linear voltage regulators designed for low-power consumption and quiescent current less than 25 μA in light-load applications. Because of an integrated fault protection, these devices are well-suited in power supplies for various automotive applications.

These devices are available in two fixed-output-voltage versions as follows:

- 5-V output version (TPS7A6550-Q1)
- 3.3-V output version (TPS7A6533-Q1)

See [Feature Description](#) for full descriptions of the features of the TPS7A65xx-Q1 voltage regulators.

7.2 Functional Block Diagram

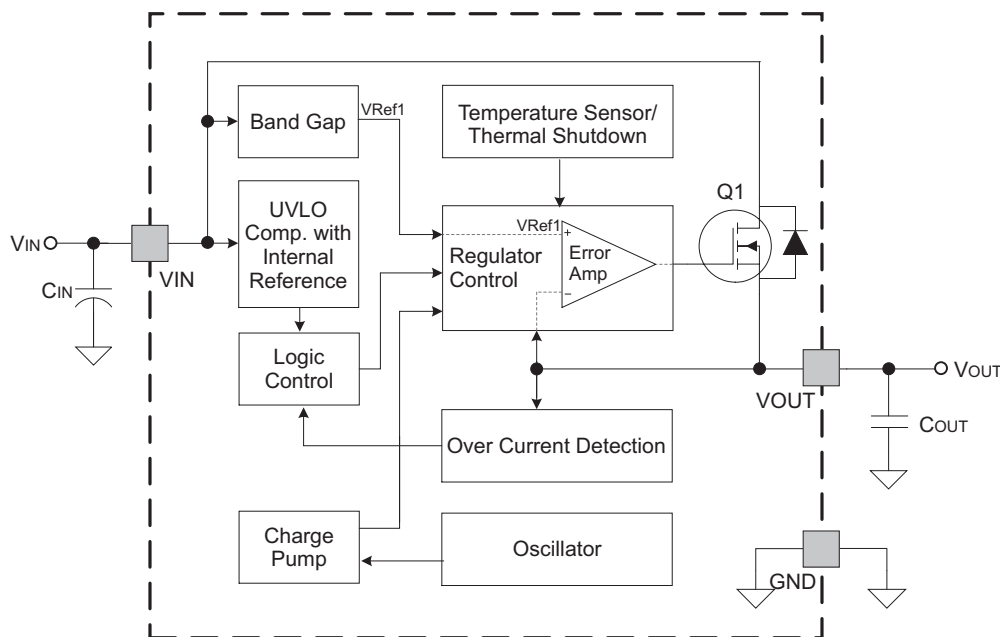

7.3 Feature Description

7.3.1 Power Up

During power up, the regulator incorporates a protection scheme to limit the current through the pass element and output capacitor. When the input voltage exceeds a certain threshold ($V_{\text{IN(POWERUP)}}$) level, the output voltage begins to ramp up; see [Figure 15](#).

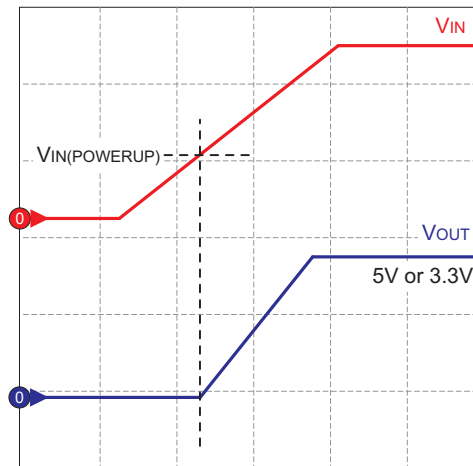
Feature Description (continued)

Figure 15. Power-Up Sequence
7.3.2 Charge-Pump Operation

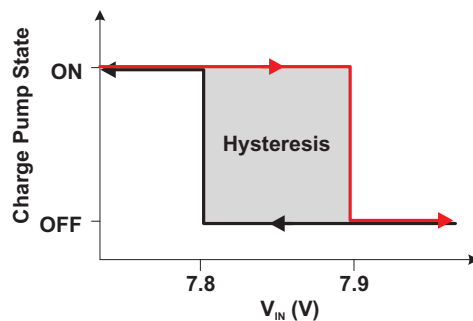
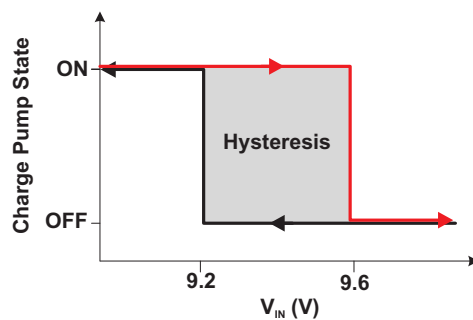
These devices have an internal charge pump that turns on or off depending on the input voltage and the output current. The charge pump switching circuitry does not cause conducted emissions to exceed required thresholds on the input voltage line. For a given output current, the charge pump stays on at lower input voltages and turns off at higher input voltages. The charge-pump switching thresholds are hysteretic. [Figure 16](#) and [Figure 17](#) show typical switching thresholds for the charge pump at light ($I_{OUT} < \text{approximately } 2 \text{ mA}$) and heavy ($I_{OUT} > \text{approximately } 2 \text{ mA}$) loads, respectively.

Figure 16. Charge-Pump Operation at Light Loads

Figure 17. Charge-Pump Operation at Heavy Loads

Feature Description (continued)

7.3.3 Low-Power Mode

At light loads and high input voltages ($V_{IN} >$ approximately 8 V such that charge pump is off) the device operates in the low-power mode and the quiescent current consumption decreases to 25 μA (typical) as shown in Table 1.

Table 1. Typical Quiescent Current Consumption

| I_{OUT} | CHARGE PUMP ON | CHARGE PUMP OFF |
|--|-------------------|--------------------------------------|
| $I_{OUT} <$ approximately 2 mA (light load) | 250 μA | 25 μA (low-power mode) |
| $I_{OUT} >$ approximately 2 mA (heavy load) | 280 μA | 70 μA |

7.3.4 Undervoltage Shutdown

These devices have an integrated undervoltage lockout (UVLO) circuit to shut down the output if the input voltage (V_{IN}) falls below an internally fixed UVLO threshold level ($V_{IN-UVLO}$) as shown in Figure 18. This ensures that the regulator does not latch into an unknown state during low input-voltage conditions. The regulator normally powers up when the input voltage exceeds the $V_{IN(POWERUP)}$ threshold.

7.3.5 Low-Voltage Tracking

At low input voltages, the regulator drops out of regulation, and the output voltage tracks input minus a voltage based on the load current (I_{OUT}) and switch resistance (R_{SW}) as shown in Figure 18. This allows for a smaller input capacitor and can possibly eliminate the need of using a boost converter during cold-crank conditions.

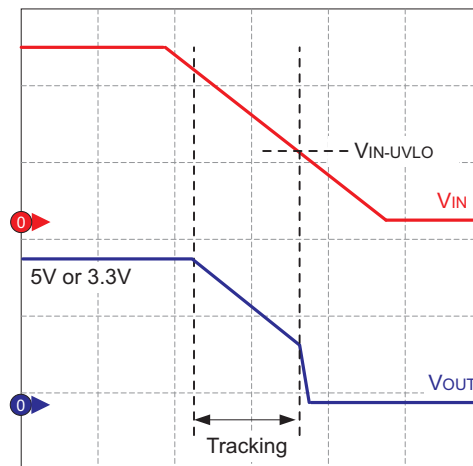

Figure 18. Undervoltage Shutdown and Low-Voltage Tracking

7.3.6 Integrated Fault Protection

These devices feature integrated fault protection to make them ideal for use in automotive applications. To keep them in a safe area of operation during certain fault conditions, they use internal current limit protection and current limit foldback to limit the maximum output current. This protects them from excessive power dissipation. For example, during a short-circuit condition on the output, limiting current through the pass element to I_{CL} protects the device from excessive power dissipation.

7.3.7 Thermal Shutdown

These devices incorporate a thermal shutdown (TSD) circuit as a protection from overheating. For continuous normal operation, the junction temperature should not exceed the TSD trip point. If the junction temperature exceeds the TSD trip point, the output turns off. When the junction temperature falls below the TSD trip point, the output turns on again. Figure 19 shows this.

Feature Description (continued)

Figure 19. Thermal Cycling Waveform for TPS7A6550-Q1 ($V_{IN} = 24\text{ V}$, $I_{OUT} = 300\text{ mA}$, $V_{OUT} = 5\text{ V}$)

7.4 Device Functional Modes

7.4.1 Operation With V_{IN} Lower Than 4 V

The TPS7A65xx-Q1 family devices operate with input voltage above 4 V. The typical UVLO voltage is 3.16 V, the device can operate at input voltage lower than 4 V. But at input voltage below the actual UVLO, the device shuts down.

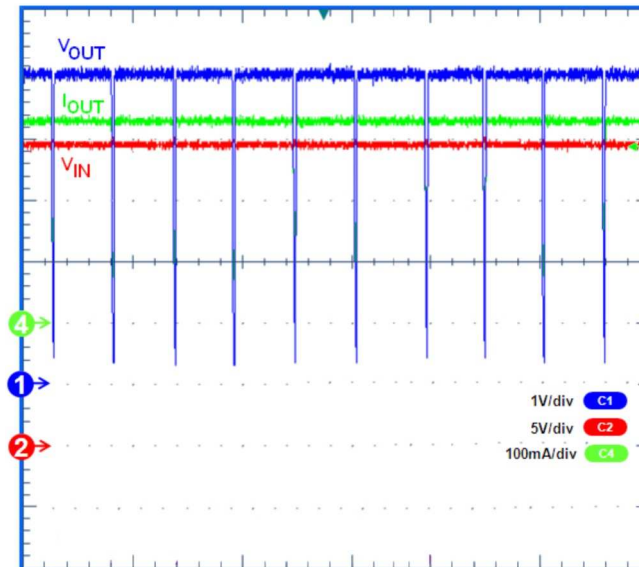
7.4.2 Operation With V_{IN} Larger Than 4 V

When V_{IN} is greater than 4 V, if the input voltage is higher than V_{OUT} plus the dropout voltage, the output voltage is equal to the set value. Otherwise, the output voltage is equal to V_{IN} minus the dropout voltage.

8 Application and Implementation

NOTE

Information in the following applications sections is not part of the TI component specification, and TI does not warrant its accuracy or completeness. TI's customers are responsible for determining suitability of components for their purposes. Customers should validate and test their design implementation to confirm system functionality.

8.1 Application Information

The TPS7A65xx-Q1 is a family of low-dropout linear voltage regulators designed for low power consumption and quiescent current less than 25 μA in light-load applications. These devices feature integrated overcurrent protection and a design to achieve stable operation even with low-ESR ceramic output capacitors. A low-voltage tracking feature allows for a smaller input capacitor and can possibly eliminate the need of using a boost converter during cold crank conditions. Because of these features, these devices are well-suited in power supplies for various automotive applications.

8.2 Typical Application

A typical application circuit for TPS7A65xx-Q1 is [Figure 20](#). Depending on the end application, one may use different values of external components. An application may require a larger output capacitor during fast load steps to prevent the output from temporarily dropping down. TI recommends a low-ESR ceramic capacitor with dielectric of type X5R or X7R. The user can additionally connect a bypass capacitor at the output to decouple high-frequency noise as per the end application.

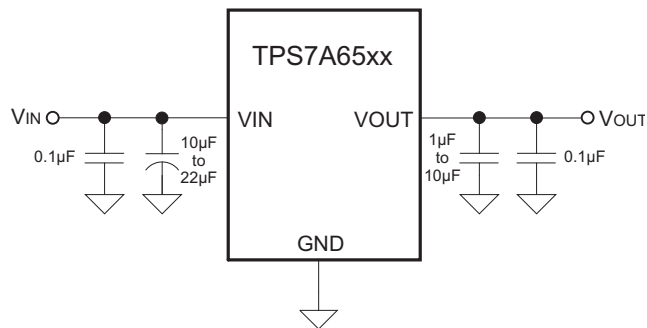

Figure 20. Typical Application Schematic

8.2.1 Design Requirements

[Table 2](#) lists the parameters for this design example.

Table 2. Design Parameters

| DESIGN PARAMETER | EXAMPLE VALUE |
|------------------------|-------------------------------------|
| Input voltage range | 4 V to 40 V |
| Output voltage | 3.3 V, 5 V |
| Output current rating | 300 mA maximum |
| Output capacitor range | 1 μF to 10 μF |

8.2.2 Detailed Design Procedure

When using TPS7A6533/50-Q1, TI recommends adding a 10- μ F to 22- μ F capacitor to the input to keep the input voltage stable. TI also recommends adding a 1- μ F to 10- μ F low ESR ceramic capacitor to get a stable output.

8.2.3 Application Curve

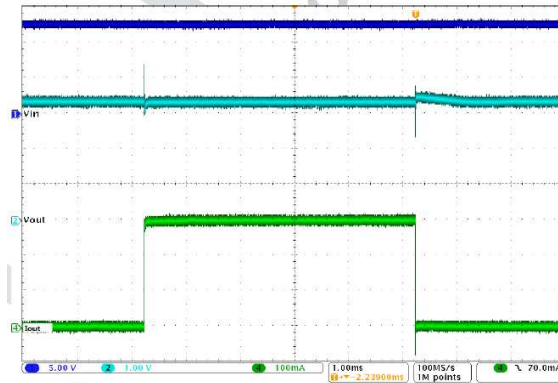

Figure 21. TPS7A6533-Q1 Load Transient Waveform

9 Power Supply Recommendations

The device is designed to operate from an input-voltage supply range from 4 V to 40 V. This input supply must be well regulated. If the input supply is located more than a few inches from the TPS7A65xx-Q1 device, TI recommends adding an electrolytic capacitor with a value of 10 μ F and a ceramic bypass capacitor at the input.

10 Layout

10.1 Layout Guidelines

For the LDO power supply, especially these high voltage and large current ones, layout is an important step. If layout is not carefully designed, the regulator could not deliver enough output current because of the thermal limitation. To improve the thermal performance of the device, and maximize the current output at high ambient temperature, TI recommends spreading the thermal pad as large as possible and putting enough thermal vias on the thermal pad.

10.2 Layout Example

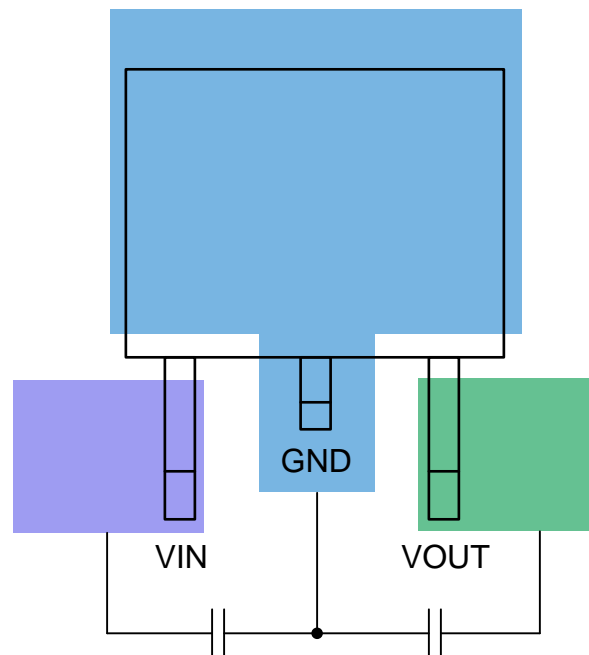

Figure 22. Layout Recommendation

10.3 Power Dissipation and Thermal Considerations

Calculate the power dissipated in the device using [Equation 1](#).

$$P_D = I_{OUT} \times (V_{IN} - V_{OUT}) + I_{QUIESCENT} \times V_{IN}$$

where

- P_D = continuous power dissipation
- I_{OUT} = output current
- V_{IN} = input voltage
- V_{OUT} = output voltage
- $I_{QUIESCENT}$ = quiescent current.

(1)

$I_{QUIESCENT} \ll I_{OUT}$; therefore, ignore the term $I_{QUIESCENT} \times V_{IN}$ in [Equation 1](#).

For a device under operation at a given ambient air temperature (T_A), calculate the junction temperature (T_J) using [Equation 2](#).

Power Dissipation and Thermal Considerations (continued)

$$T_J = T_A + (\theta_{JA} \times P_D)$$

where

- θ_{JA} = junction-to-ambient air thermal impedance. (2)

Calculate the rise in junction temperature due to power dissipation using [Equation 3](#).

$$\Delta T = T_J - T_A = (\theta_{JA} \times P_D) \quad (3)$$

For a given maximum junction temperature (T_{J-Max}), calculate the maximum ambient air temperature (T_{A-Max}) at which the device can operate using [Equation 4](#).

$$T_{A-Max} = T_{J-Max} - (\theta_{JA} \times P_D) \quad (4)$$

Example

If $I_{OUT} = 100 \text{ mA}$, $V_{OUT} = 5 \text{ V}$, $V_{IN} = 14 \text{ V}$, $I_{QUIESCENT} = 250 \text{ }\mu\text{A}$ and $\theta_{JA} = 30^\circ\text{C/W}$, the continuous power dissipated in the device is 0.9 W . The rise in junction temperature due to power dissipation is 27°C . For a maximum junction temperature of 150°C , maximum ambient air temperature at which the device can operate is 123°C .

For adequate heat dissipation, TI recommends soldering the power pad (exposed heat sink) to the thermal land pad on the PCB. Doing this provides a heat conduction path from the die to the PCB and reduces overall package thermal resistance. [Figure 23](#) shows power derating curves for the TPS7A65xx-Q1 family of devices in the KVVU (DPAK) package.

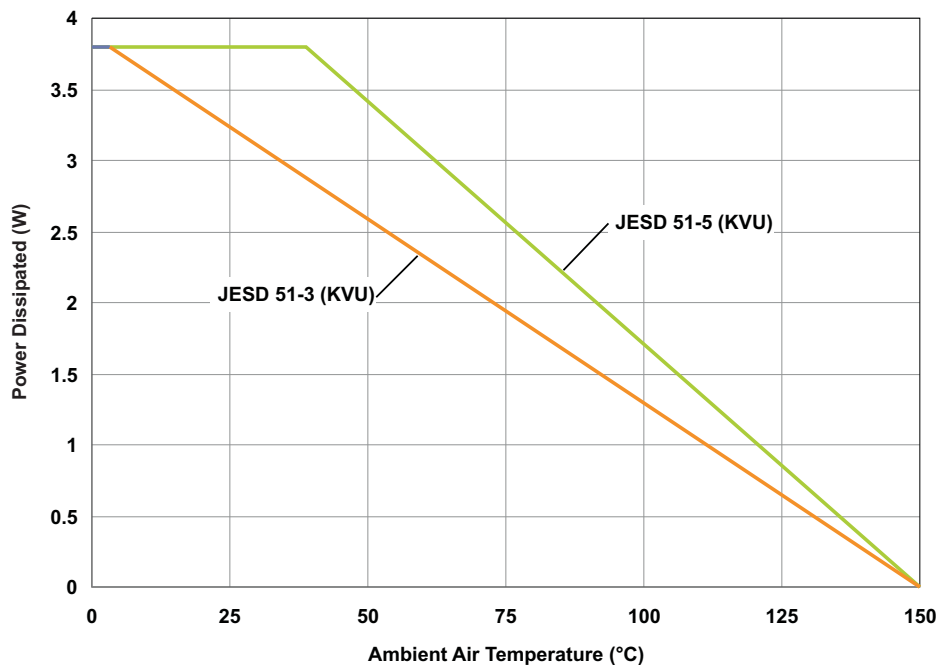

Figure 23. Power Derating Curves

For optimum thermal performance, TI recommends using a high-K PCB with thermal vias between the ground plane and solder pad or thermal land pad. [Figure 24](#) (a) and (b) show this. Further, a design can improve the heat-spreading capabilities of a PCB considerably by using a thicker ground plane and a thermal land pad with a larger surface area.

Power Dissipation and Thermal Considerations (continued)

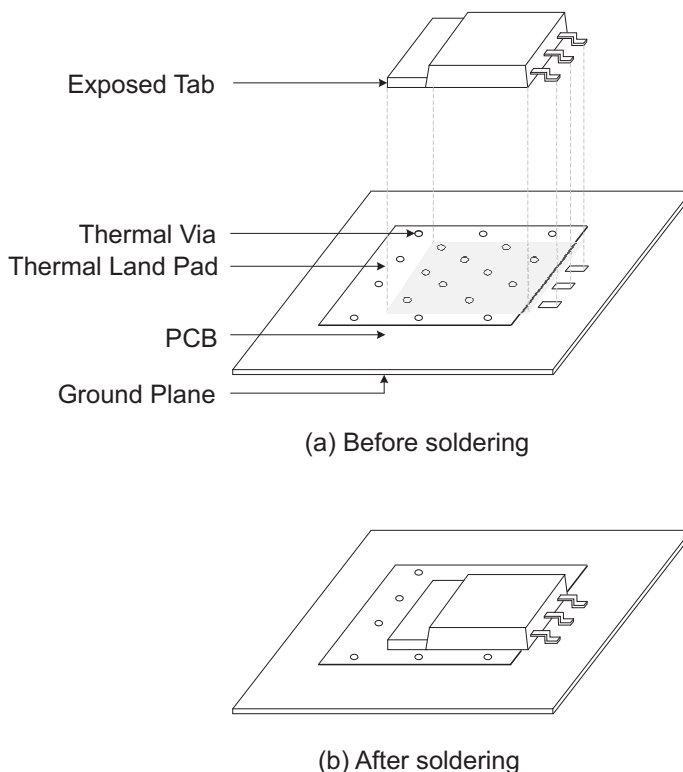

Figure 24. Using a Multilayer PCB and Thermal Vias for Adequate Heat Dissipation

Keeping other factors constant, the surface area of the thermal land pad contributes to heat dissipation only to a certain extent. Figure 25 shows the variation of θ_{JA} with surface area of the thermal land pad (soldered to the exposed pad) for the KVVU package.

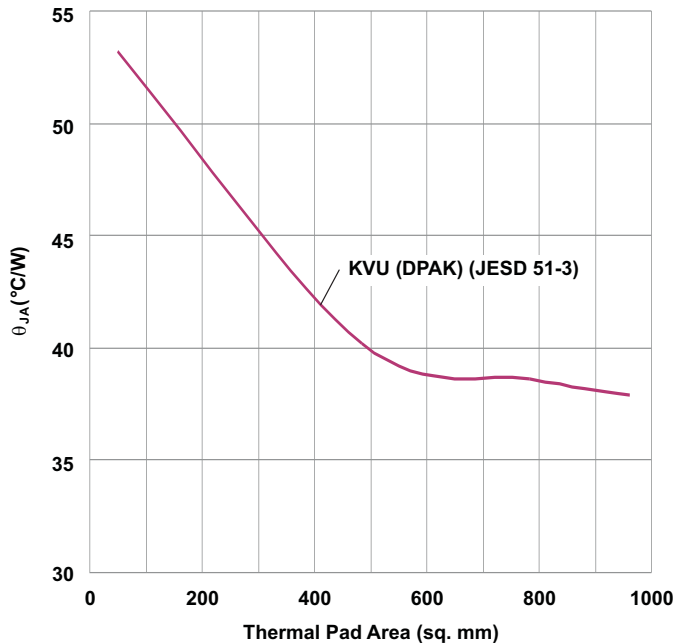

Figure 25. θ_{JA} vs Thermal Pad Area

11 Device and Documentation Support

11.1 Related Links

[Table 3](#) lists quick access links. Categories include technical documents, support and community resources, tools and software, and quick access to sample or buy.

Table 3. Related Links

| PARTS | PRODUCT FOLDER | SAMPLE & BUY | TECHNICAL DOCUMENTS | TOOLS & SOFTWARE | SUPPORT & COMMUNITY |
|--------------|----------------------------|----------------------------|----------------------------|----------------------------|----------------------------|
| TPS7A6533-Q1 | Click here | Click here | Click here | Click here | Click here |
| TPS7A6550-Q1 | Click here | Click here | Click here | Click here | Click here |

11.2 Community Resources

The following links connect to TI community resources. Linked contents are provided "AS IS" by the respective contributors. They do not constitute TI specifications and do not necessarily reflect TI's views; see TI's [Terms of Use](#).

TI E2E™ Online Community *TI's Engineer-to-Engineer (E2E) Community*. Created to foster collaboration among engineers. At e2e.ti.com, you can ask questions, share knowledge, explore ideas and help solve problems with fellow engineers.

Design Support *TI's Design Support* Quickly find helpful E2E forums along with design support tools and contact information for technical support.

11.3 Trademarks

E2E is a trademark of Texas Instruments.
All other trademarks are the property of their respective owners.

11.4 Electrostatic Discharge Caution



These devices have limited built-in ESD protection. The leads should be shorted together or the device placed in conductive foam during storage or handling to prevent electrostatic damage to the MOS gates.

11.5 Glossary

[SLYZ022](#) — *TI Glossary*.

This glossary lists and explains terms, acronyms, and definitions.

12 Mechanical, Packaging, and Orderable Information

The following pages include mechanical, packaging, and orderable information. This information is the most current data available for the designated devices. This data is subject to change without notice and revision of this document. For browser-based versions of this data sheet, refer to the left-hand navigation.

PACKAGING INFORMATION

| Orderable Device | Status (1) | Package Type | Package Drawing | Pins | Package Qty | Eco Plan (2) | Lead/Ball Finish | MSL Peak Temp (3) | Op Temp (°C) | Device Marking (4/5) | Samples |
|-------------------|---------------|--------------|-----------------|------|-------------|-------------------------|------------------|----------------------|--------------|-------------------------|-------------------------|
| TPS7A6533QKV/URQ1 | ACTIVE | TO-252 | KVU | 3 | 2500 | Green (RoHS & no Sb/Br) | CU SN | Level-3-260C-168 HR | -40 to 125 | 7A6533Q1 | Samples |
| TPS7A6550QKV/URQ1 | ACTIVE | TO-252 | KVU | 3 | 2500 | Green (RoHS & no Sb/Br) | CU SN | Level-3-260C-168 HR | -40 to 125 | 7A6550Q1 | Samples |

(1) The marketing status values are defined as follows:

ACTIVE: Product device recommended for new designs.

LIFEBUY: TI has announced that the device will be discontinued, and a lifetime-buy period is in effect.

NRND: Not recommended for new designs. Device is in production to support existing customers, but TI does not recommend using this part in a new design.

PREVIEW: Device has been announced but is not in production. Samples may or may not be available.

OBSOLETE: TI has discontinued the production of the device.

(2) Eco Plan - The planned eco-friendly classification: Pb-Free (RoHS), Pb-Free (RoHS Exempt), or Green (RoHS & no Sb/Br) - please check <http://www.ti.com/productcontent> for the latest availability information and additional product content details.

TBD: The Pb-Free/Green conversion plan has not been defined.

Pb-Free (RoHS): TI's terms "Lead-Free" or "Pb-Free" mean semiconductor products that are compatible with the current RoHS requirements for all 6 substances, including the requirement that lead not exceed 0.1% by weight in homogeneous materials. Where designed to be soldered at high temperatures, TI Pb-Free products are suitable for use in specified lead-free processes.

Pb-Free (RoHS Exempt): This component has a RoHS exemption for either 1) lead-based flip-chip solder bumps used between the die and package, or 2) lead-based die adhesive used between the die and leadframe. The component is otherwise considered Pb-Free (RoHS compatible) as defined above.

Green (RoHS & no Sb/Br): TI defines "Green" to mean Pb-Free (RoHS compatible), and free of Bromine (Br) and Antimony (Sb) based flame retardants (Br or Sb do not exceed 0.1% by weight in homogeneous material)

(3) MSL, Peak Temp. -- The Moisture Sensitivity Level rating according to the JEDEC industry standard classifications, and peak solder temperature.

(4) There may be additional marking, which relates to the logo, the lot trace code information, or the environmental category on the device.

(5) Multiple Device Markings will be inside parentheses. Only one Device Marking contained in parentheses and separated by a "~" will appear on a device. If a line is indented then it is a continuation of the previous line and the two combined represent the entire Device Marking for that device.

Important Information and Disclaimer: The information provided on this page represents TI's knowledge and belief as of the date that it is provided. TI bases its knowledge and belief on information provided by third parties, and makes no representation or warranty as to the accuracy of such information. Efforts are underway to better integrate information from third parties. TI has taken and continues to take reasonable steps to provide representative and accurate information but may not have conducted destructive testing or chemical analysis on incoming materials and chemicals. TI and TI suppliers consider certain information to be proprietary, and thus CAS numbers and other limited information may not be available for release.

In no event shall TI's liability arising out of such information exceed the total purchase price of the TI part(s) at issue in this document sold by TI to Customer on an annual basis.

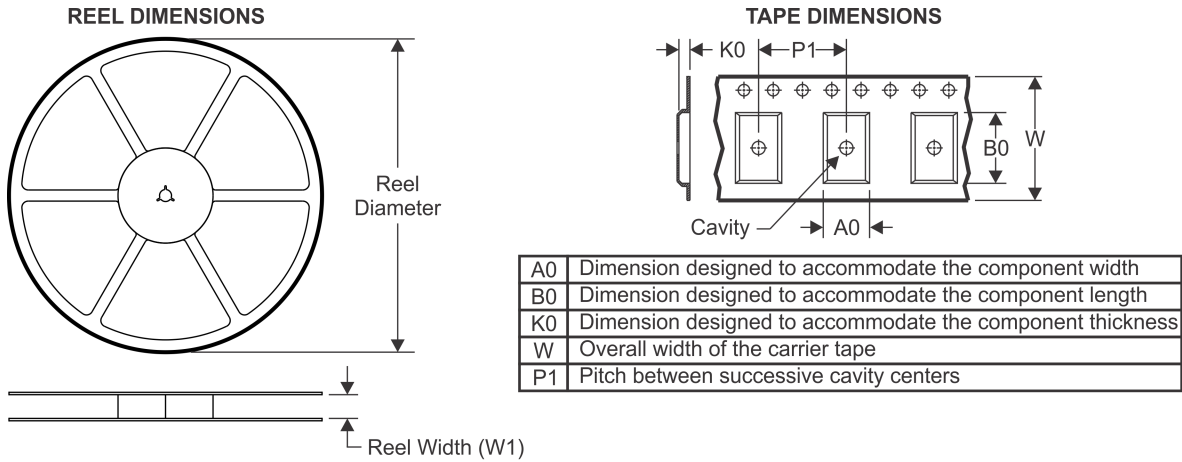
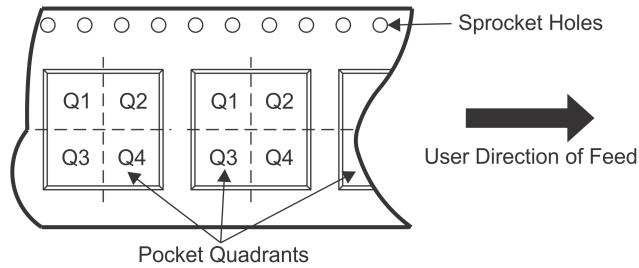
TAPE AND REEL INFORMATION

QUADRANT ASSIGNMENTS FOR PIN 1 ORIENTATION IN TAPE

*All dimensions are nominal

| Device | Package Type | Package Drawing | Pins | SPQ | Reel Diameter (mm) | Reel Width W1 (mm) | A0 (mm) | B0 (mm) | K0 (mm) | P1 (mm) | W (mm) | Pin1 Quadrant |
|------------------|--------------|-----------------|------|------|--------------------|--------------------|---------|---------|---------|---------|--------|---------------|
| TPS7A6533QKVURQ1 | TO-252 | KVU | 3 | 2500 | 330.0 | 16.4 | 6.9 | 10.5 | 2.7 | 8.0 | 16.0 | Q2 |
| TPS7A6550QKVURQ1 | TO-252 | KVU | 3 | 2500 | 330.0 | 16.4 | 6.9 | 10.5 | 2.7 | 8.0 | 16.0 | Q2 |

TAPE AND REEL BOX DIMENSIONS



*All dimensions are nominal

| Device | Package Type | Package Drawing | Pins | SPQ | Length (mm) | Width (mm) | Height (mm) |
|------------------|--------------|-----------------|------|------|-------------|------------|-------------|
| TPS7A6533QKVURQ1 | TO-252 | KVU | 3 | 2500 | 340.0 | 340.0 | 38.0 |
| TPS7A6550QKVURQ1 | TO-252 | KVU | 3 | 2500 | 340.0 | 340.0 | 38.0 |

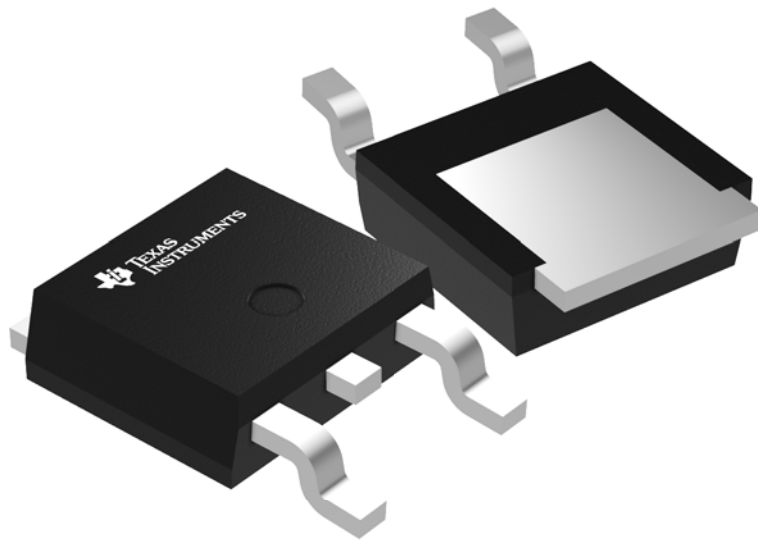

Images above are just a representation of the package family, actual package may vary.
Refer to the product data sheet for package details.



PACKAGE OUTLINE

KVVU0003A

TO-252 - 2.52 mm max height

TO-252

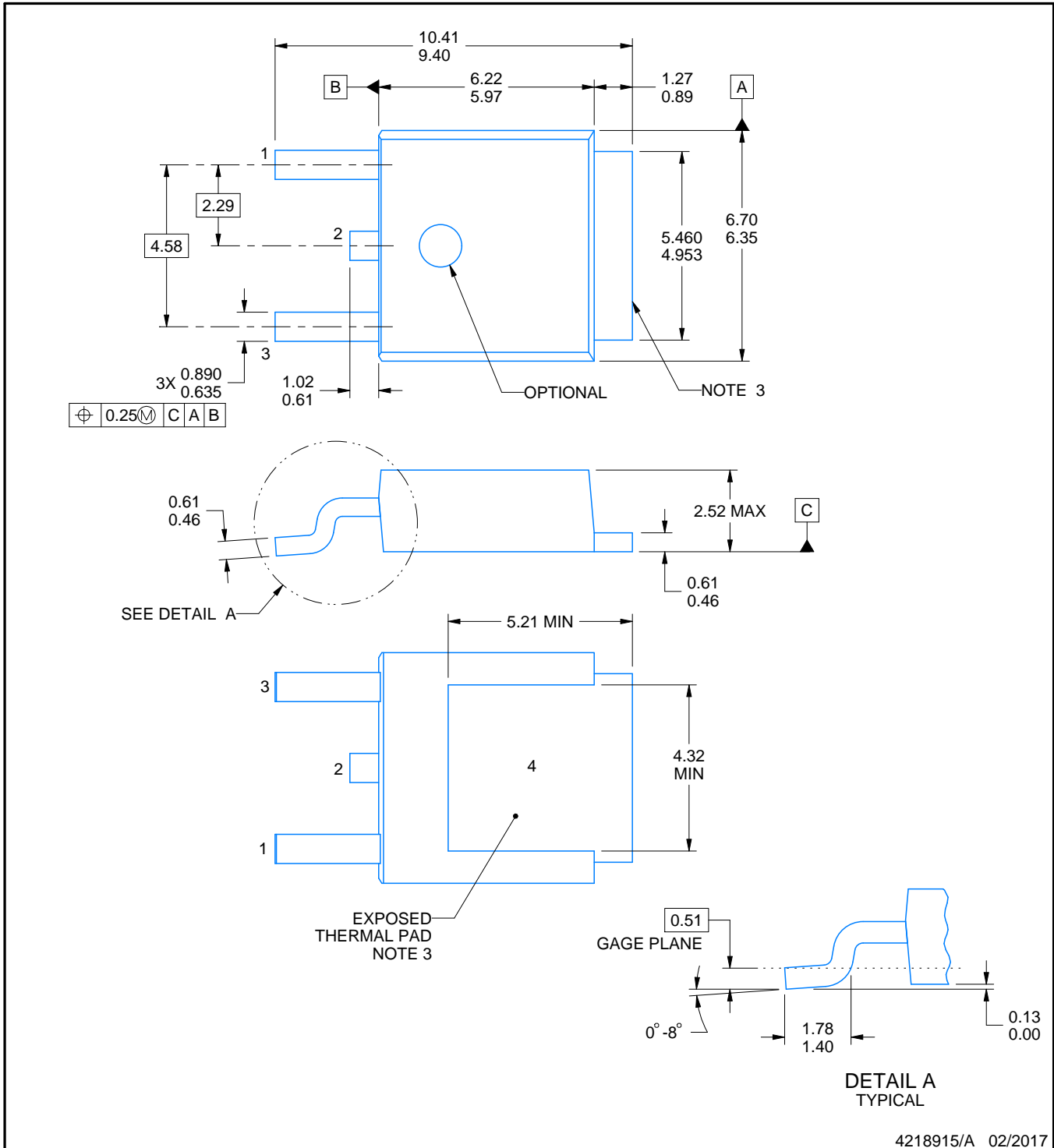

NOTES:

1. All linear dimensions are in millimeters. Any dimensions in parenthesis are for reference only. Dimensioning and tolerancing per ASME Y14.5M.
2. This drawing is subject to change without notice.
3. Shape may vary per different assembly sites.
4. Reference JEDEC registration TO-252.

EXAMPLE BOARD LAYOUT

KVU0003A

TO-252 - 2.52 mm max height

TO-252

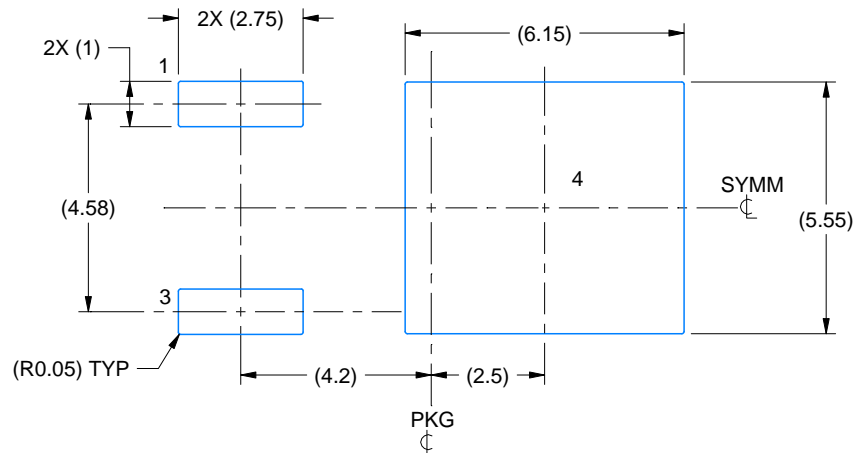

LAND PATTERN EXAMPLE
EXPOSED METAL SHOWN
SCALE:6X

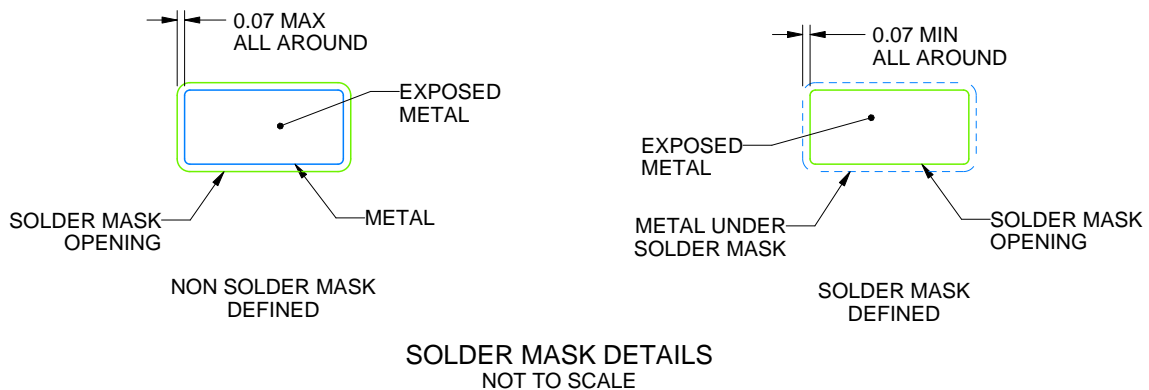

SOLDER MASK DETAILS
NOT TO SCALE

4218915/A 02/2017

NOTES: (continued)

5. This package is designed to be soldered to a thermal pad on the board. For more information, see Texas Instruments literature numbers SLMA002 (www.ti.com/lit/slm002) and SLMA004 (www.ti.com/lit/slma004).
6. Vias are optional depending on application, refer to device data sheet. It is recommended that vias under paste be filled, plugged or tented.

EXAMPLE STENCIL DESIGN

KVU0003A

TO-252 - 2.52 mm max height

TO-252

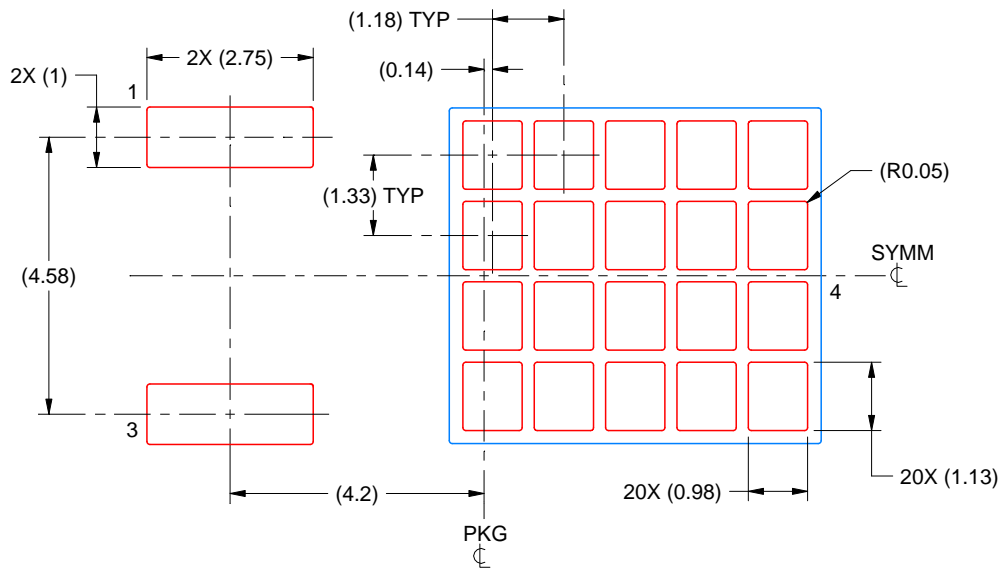

SOLDER PASTE EXAMPLE
BASED ON 0.125 mm THICK STENCIL

EXPOSED PAD
65% PRINTED SOLDER COVERAGE BY AREA
SCALE:8X

4218915/A 02/2017

NOTES: (continued)

7. Laser cutting apertures with trapezoidal walls and rounded corners may offer better paste release. IPC-7525 may have alternate design recommendations.
8. Board assembly site may have different recommendations for stencil design.

IMPORTANT NOTICE

Texas Instruments Incorporated (TI) reserves the right to make corrections, enhancements, improvements and other changes to its semiconductor products and services per JESD46, latest issue, and to discontinue any product or service per JESD48, latest issue. Buyers should obtain the latest relevant information before placing orders and should verify that such information is current and complete.

TI's published terms of sale for semiconductor products (<http://www.ti.com/sc/docs/stdterms.htm>) apply to the sale of packaged integrated circuit products that TI has qualified and released to market. Additional terms may apply to the use or sale of other types of TI products and services.

Reproduction of significant portions of TI information in TI data sheets is permissible only if reproduction is without alteration and is accompanied by all associated warranties, conditions, limitations, and notices. TI is not responsible or liable for such reproduced documentation. Information of third parties may be subject to additional restrictions. Resale of TI products or services with statements different from or beyond the parameters stated by TI for that product or service voids all express and any implied warranties for the associated TI product or service and is an unfair and deceptive business practice. TI is not responsible or liable for any such statements.

Buyers and others who are developing systems that incorporate TI products (collectively, "Designers") understand and agree that Designers remain responsible for using their independent analysis, evaluation and judgment in designing their applications and that Designers have full and exclusive responsibility to assure the safety of Designers' applications and compliance of their applications (and of all TI products used in or for Designers' applications) with all applicable regulations, laws and other applicable requirements. Designer represents that, with respect to their applications, Designer has all the necessary expertise to create and implement safeguards that (1) anticipate dangerous consequences of failures, (2) monitor failures and their consequences, and (3) lessen the likelihood of failures that might cause harm and take appropriate actions. Designer agrees that prior to using or distributing any applications that include TI products, Designer will thoroughly test such applications and the functionality of such TI products as used in such applications.

TI's provision of technical, application or other design advice, quality characterization, reliability data or other services or information, including, but not limited to, reference designs and materials relating to evaluation modules, (collectively, "TI Resources") are intended to assist designers who are developing applications that incorporate TI products; by downloading, accessing or using TI Resources in any way, Designer (individually or, if Designer is acting on behalf of a company, Designer's company) agrees to use any particular TI Resource solely for this purpose and subject to the terms of this Notice.

TI's provision of TI Resources does not expand or otherwise alter TI's applicable published warranties or warranty disclaimers for TI products, and no additional obligations or liabilities arise from TI providing such TI Resources. TI reserves the right to make corrections, enhancements, improvements and other changes to its TI Resources. TI has not conducted any testing other than that specifically described in the published documentation for a particular TI Resource.

Designer is authorized to use, copy and modify any individual TI Resource only in connection with the development of applications that include the TI product(s) identified in such TI Resource. NO OTHER LICENSE, EXPRESS OR IMPLIED, BY ESTOPPEL OR OTHERWISE TO ANY OTHER TI INTELLECTUAL PROPERTY RIGHT, AND NO LICENSE TO ANY TECHNOLOGY OR INTELLECTUAL PROPERTY RIGHT OF TI OR ANY THIRD PARTY IS GRANTED HEREIN, including but not limited to any patent right, copyright, mask work right, or other intellectual property right relating to any combination, machine, or process in which TI products or services are used. Information regarding or referencing third-party products or services does not constitute a license to use such products or services, or a warranty or endorsement thereof. Use of TI Resources may require a license from a third party under the patents or other intellectual property of the third party, or a license from TI under the patents or other intellectual property of TI.

TI RESOURCES ARE PROVIDED "AS IS" AND WITH ALL FAULTS. TI DISCLAIMS ALL OTHER WARRANTIES OR REPRESENTATIONS, EXPRESS OR IMPLIED, REGARDING RESOURCES OR USE THEREOF, INCLUDING BUT NOT LIMITED TO ACCURACY OR COMPLETENESS, TITLE, ANY EPIDEMIC FAILURE WARRANTY AND ANY IMPLIED WARRANTIES OF MERCHANTABILITY, FITNESS FOR A PARTICULAR PURPOSE, AND NON-INFRINGEMENT OF ANY THIRD PARTY INTELLECTUAL PROPERTY RIGHTS. TI SHALL NOT BE LIABLE FOR AND SHALL NOT DEFEND OR INDEMNIFY DESIGNER AGAINST ANY CLAIM, INCLUDING BUT NOT LIMITED TO ANY INFRINGEMENT CLAIM THAT RELATES TO OR IS BASED ON ANY COMBINATION OF PRODUCTS EVEN IF DESCRIBED IN TI RESOURCES OR OTHERWISE. IN NO EVENT SHALL TI BE LIABLE FOR ANY ACTUAL, DIRECT, SPECIAL, COLLATERAL, INDIRECT, PUNITIVE, INCIDENTAL, CONSEQUENTIAL OR EXEMPLARY DAMAGES IN CONNECTION WITH OR ARISING OUT OF TI RESOURCES OR USE THEREOF, AND REGARDLESS OF WHETHER TI HAS BEEN ADVISED OF THE POSSIBILITY OF SUCH DAMAGES.

Unless TI has explicitly designated an individual product as meeting the requirements of a particular industry standard (e.g., ISO/TS 16949 and ISO 26262), TI is not responsible for any failure to meet such industry standard requirements.

Where TI specifically promotes products as facilitating functional safety or as compliant with industry functional safety standards, such products are intended to help enable customers to design and create their own applications that meet applicable functional safety standards and requirements. Using products in an application does not by itself establish any safety features in the application. Designers must ensure compliance with safety-related requirements and standards applicable to their applications. Designer may not use any TI products in life-critical medical equipment unless authorized officers of the parties have executed a special contract specifically governing such use. Life-critical medical equipment is medical equipment where failure of such equipment would cause serious bodily injury or death (e.g., life support, pacemakers, defibrillators, heart pumps, neurostimulators, and implantables). Such equipment includes, without limitation, all medical devices identified by the U.S. Food and Drug Administration as Class III devices and equivalent classifications outside the U.S.

TI may expressly designate certain products as completing a particular qualification (e.g., Q100, Military Grade, or Enhanced Product). Designers agree that it has the necessary expertise to select the product with the appropriate qualification designation for their applications and that proper product selection is at Designers' own risk. Designers are solely responsible for compliance with all legal and regulatory requirements in connection with such selection.

Designer will fully indemnify TI and its representatives against any damages, costs, losses, and/or liabilities arising out of Designer's non-compliance with the terms and provisions of this Notice.