

DUAL-OUTPUT LOW-DROPOUT LINEAR REGULATOR

Check for Samples: [TPS767D301-EP](#)

FEATURES

- **Controlled Baseline**
 - One Assembly/Test Site, One Fabrication Site
- **Extended Temperature Performance of –55°C to 125°C**
- **Enhanced Diminishing Manufacturing Sources (DMS) Support**
- **Enhanced Product-Change Notification**
- **Qualification Pedigree**
- **1- μ A Quiescent Current During Shutdown**
- **Dual Open-Drain Power-On Reset With 200-ms Delay for Each Regulator**
- **28-Pin PowerPAD™ TSSOP Package**
- **Thermal Shutdown Protection for Each Regulator**

Component qualification in accordance with JEDEC and industry standards to ensure reliable operation over an extended temperature range. This includes, but is not limited to, Highly Accelerated Stress Test (HAST) or biased 85/85, temperature cycle, autoclave or unbiased HAST, electromigration, bond intermetallic life, and mold compound life. Such qualification testing should not be viewed as justifying use of this component beyond specified performance and environmental limits.

- **Dual Output Voltages for Split-Supply Applications**
- **Output Current Range of 0 mA to 1.0 A Per Regulator**
- **3.3-V/Adjustable Output**
- **Fast Transient Response**
- **3% Tolerance Over Load and Temperature**
- **Dropout Voltage Typically 350 mV at 1 A**
- **Ultra-Low 85- μ A Typical Quiescent Current**

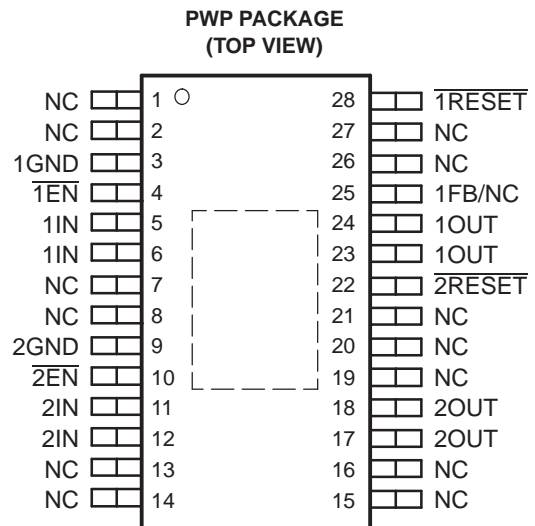

NC – No internal connection

DESCRIPTION/ORDERING INFORMATION

The TPS767D301-EP dual-voltage regulator offers fast transient response, low dropout (LDO) voltages, and dual outputs in a compact package and incorporates stability with 10- μ F low-ESR output capacitors.

The TPS767D301-EP dual-voltage regulator is designed primarily for DSP applications. This device can be used in any mixed-output voltage application, with each regulator supporting up to 1 A. Dual active-low reset (RESET) signals allow resetting of core logic and I/O separately.

Table 1. ORDERING INFORMATION

T_J	REGULATOR 1 V_O	REGULATOR 2 V_O	TSSOP (PWP)
–55°C to 125°C	Adjustable (1.5 V to 5.5 V)	3.3 V	TPS767D301MPWPREP



Please be aware that an important notice concerning availability, standard warranty, and use in critical applications of Texas Instruments semiconductor products and disclaimers thereto appears at the end of this data sheet.

DESCRIPTION/ORDERING INFORMATION (CONTINUED)

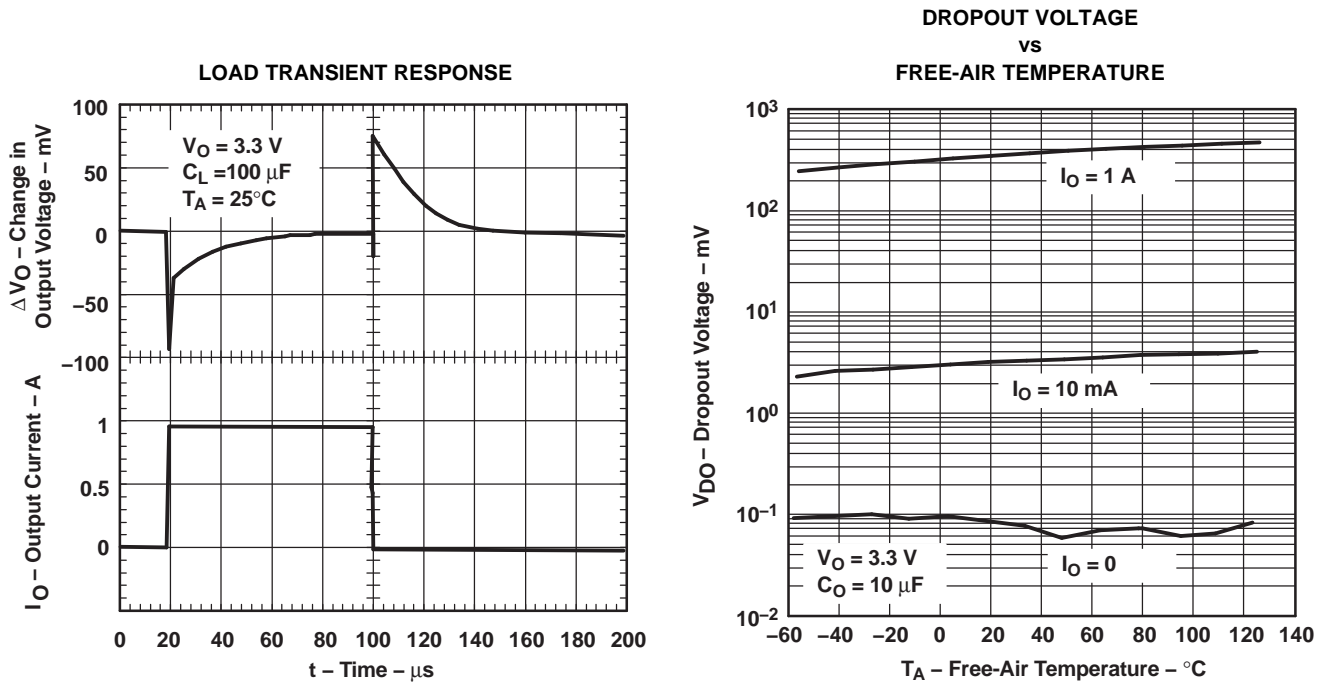

Because the PMOS device behaves as a low-value resistor, the dropout voltage is very low and is directly proportional to the output current. Additionally, since the PMOS pass element is a voltage-driven device, the quiescent current is very low and independent of output loading (typically 85 μA over the full range of output current, 0 mA to 1 A). These two key specifications yield a significant improvement in operating life for battery-powered systems. This LDO device also features a sleep mode; applying a TTL high signal to enable ($\overline{\text{EN}}$) shuts down the regulator, reducing the quiescent current to 1 μA at T_J = 25°C.

The $\overline{\text{RESET}}$ output of the TPS767D301-EP initiates a reset in microcomputer and microprocessor systems in the event of an undervoltage condition. An internal comparator in the TPS767D301-EP monitors the output voltage of the regulator to detect an undervoltage condition on the regulated output voltage.

The TPS767D301-EP is offered in an adjustable version (programmable over the range of 1.5 V to 5.5 V). Output voltage tolerance is specified as a maximum of 3% over line, load, and temperature ranges. The TPS767D301-EP is available in a 28-pin PWP (TSSOP) package. The device operates over a junction temperature range of -55°C to 125°C.

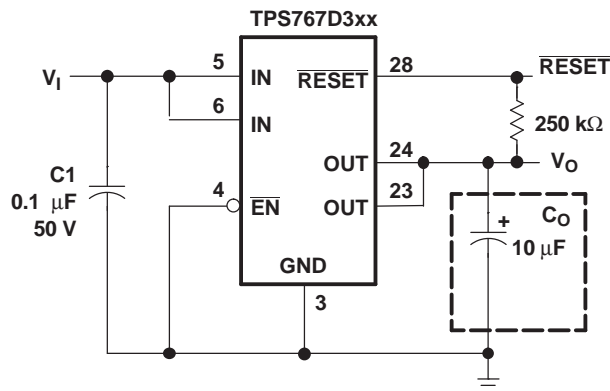
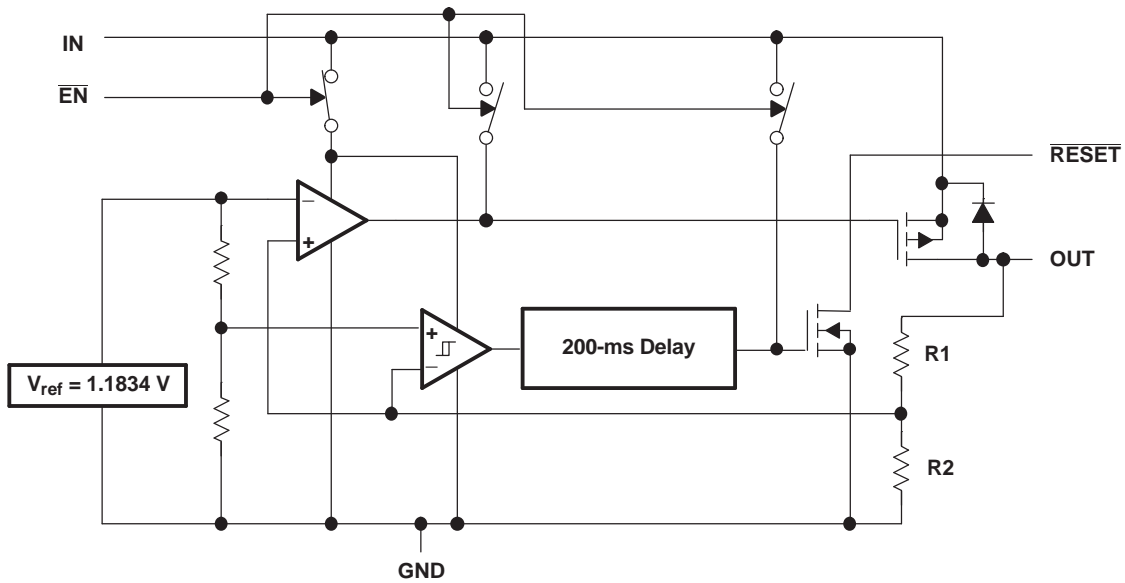
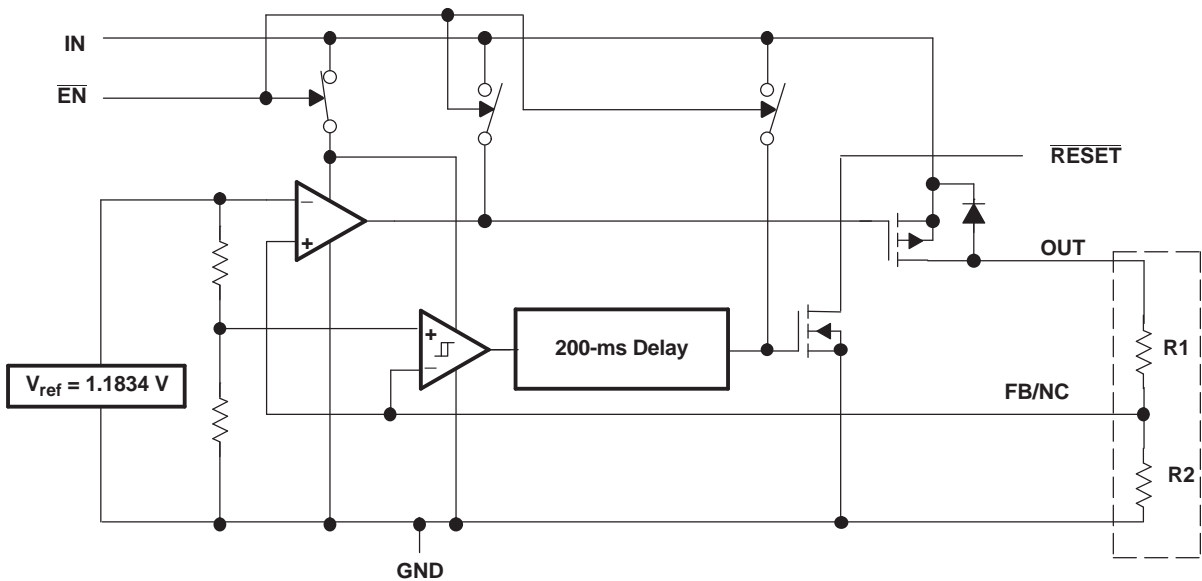

Figure 1. Typical Application Circuit (Fixed Versions) for Single Channel

FUNCTIONAL BLOCK DIAGRAM
Adjustable Version (for Each LDO)



FUNCTIONAL BLOCK DIAGRAM
Fixed-Voltage Version (for Each LDO)



External to the device

TERMINAL FUNCTIONS

TERMINAL		I/O	DESCRIPTION
NAME	NO.		
1GND	3		Regulator 1 ground
$\overline{1EN}$	4	I	Regulator 1 enable
1IN	5, 6	I	Regulator 1 input supply voltage
2GND	9		Regulator 2 ground
$\overline{2EN}$	10	I	Regulator 2 enable
2IN	11, 12	I	Regulator 2 input supply voltage
2OUT	17, 18	O	Regulator 2 output voltage
$\overline{2RESET}$	22	O	Regulator 2 reset
1OUT	23, 24	O	Regulator 1 output voltage
1FB/NC	25	I	Regulator 1 output voltage feedback for adjustable version and no connect for fixed-output version
$\overline{1RESET}$	28	O	Regulator 1 reset
NC	1, 2, 7, 8, 13–16, 19–21, 26, 27		No connection

TIMING DIAGRAM

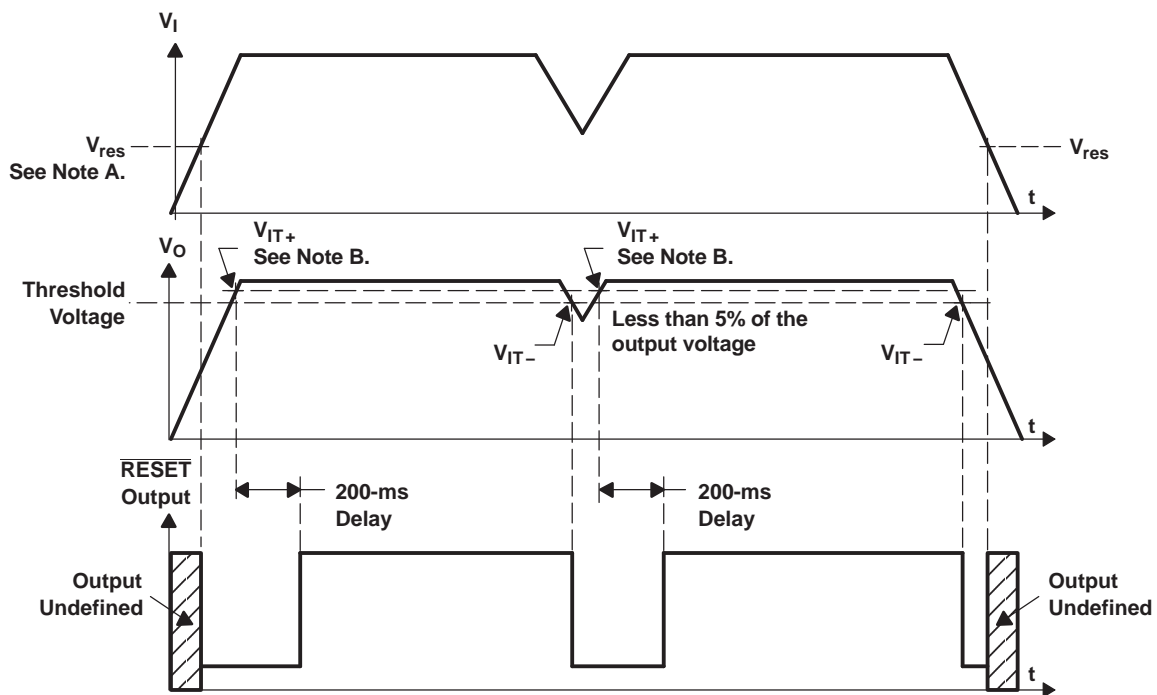

- A. V_{res} is the minimum input voltage for a valid \overline{RESET} . The symbol V_{res} is not currently listed within EIA or JEDEC standards for semiconductor symbology.
- B. V_{IT-} – Trip voltage typically is 5% lower than the output voltage (95% V_o).

Absolute Maximum Ratings

over operating free-air temperature range (unless otherwise noted) ⁽¹⁾

			MIN	MAX	UNIT
V _I	Input voltage range ⁽²⁾		-0.3	13.5	V
V _I	Input voltage range	1IN, 2IN, $\overline{\text{EN}}$	-0.3	V _I + 0.3	V
V _O	Output voltage	1OUT, 2OUT		7	V
		$\overline{\text{RESET}}$		16.5	
	Peak output current		Internally limited		
HBM	ESD rating			2	kV
	Continuous total power dissipation		See Dissipation Rating Table		
T _J	Operating virtual junction temperature range		-55	150	°C
T _{stg}	Storage temperature range		-65	150	°C

- (1) Stresses beyond those listed under *absolute maximum ratings* may cause permanent damage to the device. These are stress ratings only, and functional operation of the device at these or any other conditions beyond those indicated under *recommended operating conditions* is not implied. Exposure to absolute-maximum-rated conditions for extended periods may affect device reliability.
- (2) All voltage values are with respect to network ground terminal.

Table 2. DISSIPATION RATING TABLE

PACKAGE	AIR FLOW (CFM)	T _A ≤ 25°C POWER RATING	DERATING FACTOR ABOVE T _A = 25°C	T _A = 70°C POWER RATING	T _A = 85°C POWER RATING
PWP ⁽¹⁾	0	3.58 W	35.8 mW/°C	1.97 W	1.43 W
	250	5.07 W	50.7 mW/°C	2.79 W	2.03 W

- (1) This parameter is measured with the recommended copper heat-sink pattern on a four-layer PCB, 1-oz copper on 4-in × 4-in ground layer. For more information, refer to TI technical brief literature number SLMA002.

Recommended Operating Conditions

			MIN	MAX	UNIT
V _I	Input voltage ⁽¹⁾	1IN, 2IN	2.7	10	V
I _O	Output current for each LDO ⁽²⁾		0	1	A
V _O	Output voltage range	1OUT, 2OUT	1.5	5.5	V
T _J	Operating virtual junction temperature		-55	125	°C

- (1) To calculate the minimum input voltage for maximum output current, use the following equation:

$$V_{I(\min)} = V_{O(\max)} + V_{DO(\max \text{ load})}$$

- (2) Continuous output current and operating junction temperature are limited by internal protection circuitry, but it is not recommended that the device operate under conditions beyond those specified in this table for extended periods of time.

Electrical Characteristics

$V_i = V_{O(nom)} + 1\text{ V}$, $I_o = 1\text{ mA}$, $\overline{EN} = 0$, $C_o = 10\text{ }\mu\text{F}$ (unless otherwise noted)

PARAMETER		TEST CONDITIONS		MIN	TYP	MAX	UNIT
V_o	Output voltage ⁽¹⁾	Adjustable	$1.5\text{ V} \leq V_o \leq 5.5\text{ V}$, $10\text{ }\mu\text{A} < I_o < 1\text{ A}$	$T_J = 25^\circ\text{C}$	V_o		V
				$T_J = -55^\circ\text{C}$ to 125°C	0.97 V_o	1.02 V_o	
3.3-V output	$4.3\text{ V} < V_i < 10\text{ V}$, $10\text{ }\mu\text{A} < I_o < 1\text{ A}$	$T_J = 25^\circ\text{C}$	3.3				
		$T_J = -55^\circ\text{C}$ to 125°C	3.201	3.366			
Quiescent current (GND current) for each LDO ⁽¹⁾		$10\text{ }\mu\text{A} < I_o < 1\text{ A}$, $T_J = 25^\circ\text{C}$		85		μA	
		$I_o = 1\text{ A}$, $T_J = -55^\circ\text{C}$ to 125°C		125			
$\Delta V_o/V_o$	Output voltage line regulation for each LDO ^{(1) (2)}	$V_o + 1\text{ V} < V_i \leq 10\text{ V}$, $T_J = 25^\circ\text{C}$		0.01		%/V	
Output noise voltage		BW = 200 Hz to 100 kHz, $V_o = 1.8\text{ V}$, $I_c = 1\text{ A}$, $C_o = 10\text{ }\mu\text{F}$, $T_J = 25^\circ\text{C}$		55		μV_{RMS}	
Output current limit for each LDO		$V_o = 0\text{ V}$		1.7	2	A	
Thermal shutdown junction temperature				150		$^\circ\text{C}$	
Standby current for each LDO		$2.7\text{ V} < V_i < 10\text{ V}$, $\overline{EN} = V_i$	$T_J = 25^\circ\text{C}$	1		μA	
			$T_J = -55^\circ\text{C}$ to 125°C	10			
FB input current	Adjustable	FB = 1.5		2		nA	
High-level enable input voltage				2		V	
Low-level enable input voltage				0.8		V	
Power-supply ripple rejection ⁽¹⁾		$f = 1\text{ KHz}$, $T_J = 25^\circ\text{C}$, $C_o = 10\text{ }\mu\text{F}$		60		dB	
Reset	Minimum input voltage for valid RESET	$I_{O(\text{RESET})} = 300\text{ }\mu\text{A}$		1.1		V	
	Trip threshold voltage	V_o decreasing		92	98	%/ V_o	
	Hysteresis voltage	Measured at V_o		0.5			
	Output low voltage	$V_i = 2.7\text{ V}$, $I_{O(\text{RESET})} = 1\text{ mA}$		0.15	0.4	V	
	Leakage current	$V(\text{RESET}) = 7\text{ V}$		1		μA	
	RESET time-out delay			200		mV	
Input current	\overline{EN}	$\overline{EN} = 0\text{ V}$		-1	0	1	μA
		$\overline{EN} = V_i$		-1		1	
Load regulation				3		mV	
Dropout voltage ⁽³⁾		$V_o = 3.3\text{ V}$, $I_o = 1\text{ A}$	$T_J = 25^\circ\text{C}$	350		mV	
			$T_J = -55^\circ\text{C}$ to 125°C	575			

(1) The minimum IN operating voltage is 2.7 V or $V_{O(\text{typ})} + 1\text{ V}$, whichever is greater. The maximum IN voltage is 10 V.

(2) If $V_o \leq 1.8\text{ V}$ then $V_{i(\text{min})} = 2.7\text{ V}$, $V_{i(\text{max})} = 10\text{ V}$:

$$\text{Line regulator (mV)} = (\%/\text{V}) \times \frac{V_o(V_{i(\text{max})} - 2.7\text{ V})}{100} \times 1000$$

If $V_o \geq 2.5\text{ V}$, then $V_{i(\text{min})} = V_o + 1\text{ V}$, and $V_{i(\text{max})} = 10\text{ V}$:

$$\text{Line regulator (mV)} = (\%/\text{V}) \times \frac{V_o[V_{i(\text{max})} - (V_o + 1\text{ V})]}{100} \times 1000$$

(3) IN voltage equals $V_{O(\text{typ})} - 100\text{ mV}$; adjustable output voltage set to 3.3 V nominal with external resistor divider. Dropout voltage of 1.8 V and 2.5 V is limited by input voltage-range limitations.

TYPICAL CHARACTERISTICS

Table 3. TABLE OF GRAPHS

		FIGURE
Output voltage	vs Output current	3, 4, 5
	vs Free-air temperature	6, 7, 8
Ground current	vs Free-air temperature	9, 10
Power-supply ripple rejection	vs Frequency	11
Output spectral noise density	vs Frequency	12
Output impedance	vs Frequency	13
Dropout voltage	vs Free-air temperature	14
Line transient response		15, 17
Load transient response		16, 18
Output voltage	vs Time	19
Dropout voltage	vs Input voltage	20
Equivalent series resistance (ESR)	vs Output current, $T_A = 25^\circ\text{C}$	22
	vs Output current, $T_J = 125^\circ\text{C}$	23
	vs Output Current, $T_A = 25^\circ\text{C}$	24
	vs Output current, $T_J = 125^\circ\text{C}$	25

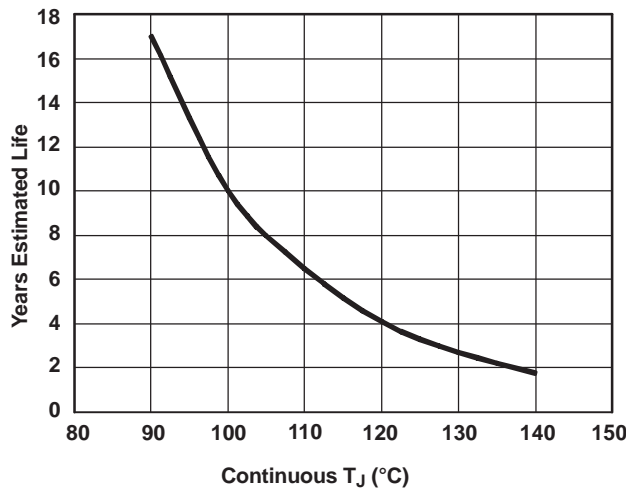

Figure 2. TPS767D301MPWPREP Estimated Device Life at Elevated Temperatures Wirebond Voiding Fail Mode

TYPICAL CHARACTERISTICS (continued)

OUTPUT VOLTAGE
vs
OUTPUT CURRENT

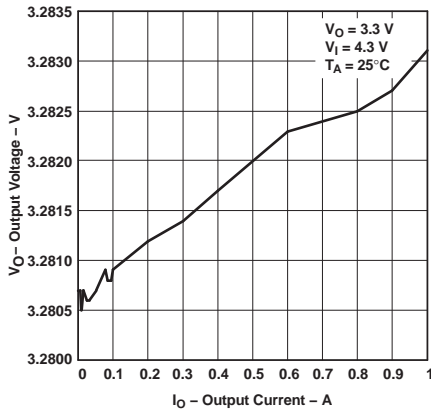

Figure 3.

OUTPUT VOLTAGE
vs
OUTPUT CURRENT

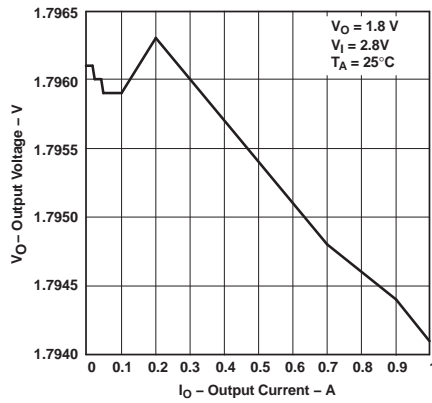

Figure 4.

OUTPUT VOLTAGE
vs
OUTPUT CURRENT

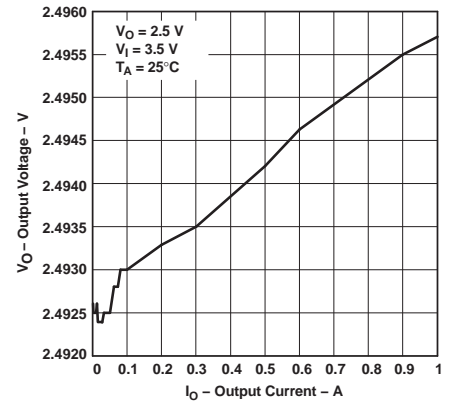

Figure 5.

OUTPUT VOLTAGE
vs
FREE-AIR TEMPERATURE

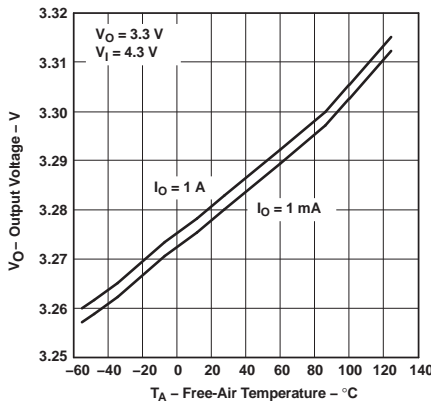

Figure 6.

OUTPUT VOLTAGE
vs
FREE-AIR TEMPERATURE

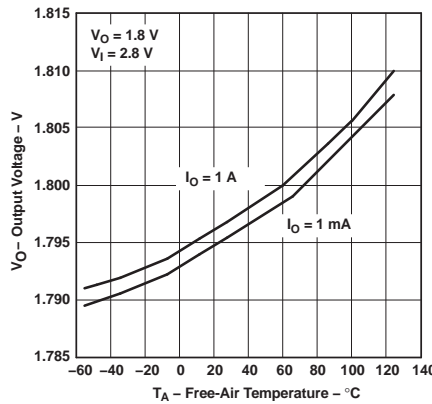

Figure 7.

OUTPUT VOLTAGE
vs
FREE-AIR TEMPERATURE

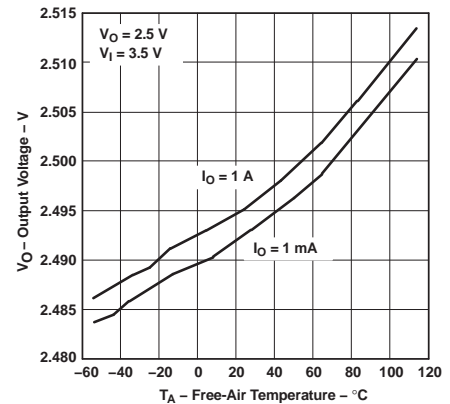

Figure 8.

TYPICAL CHARACTERISTICS (continued) (continued)

GROUND CURRENT
VS
FREE-AIR TEMPERATURE

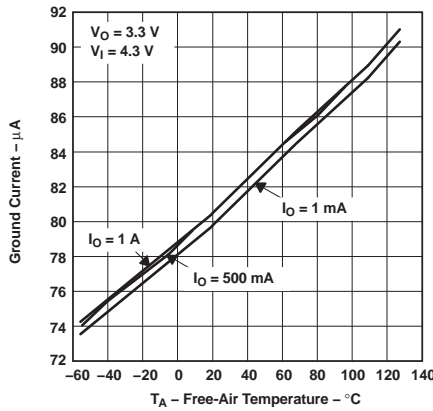

Figure 9.

GROUND CURRENT
VS
FREE-AIR TEMPERATURE

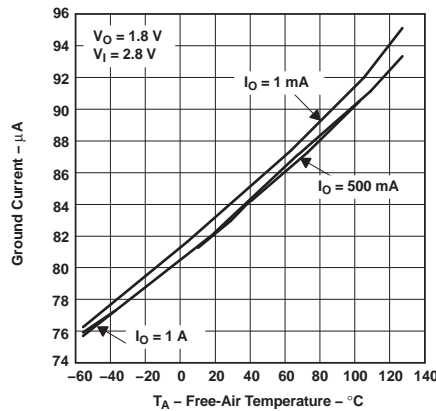

Figure 10.

POWER-SUPPLY RIPPLE
REJECTION
VS
FREQUENCY

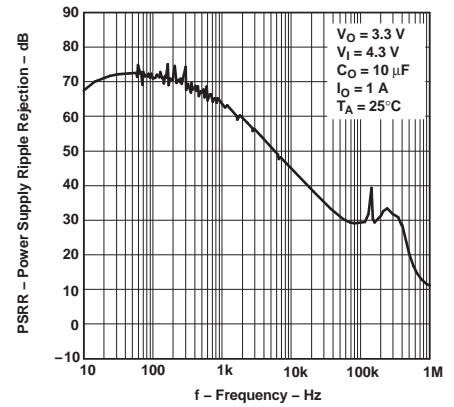

Figure 11.

OUTPUT SPECTRAL NOISE
DENSITY
VS
FREQUENCY

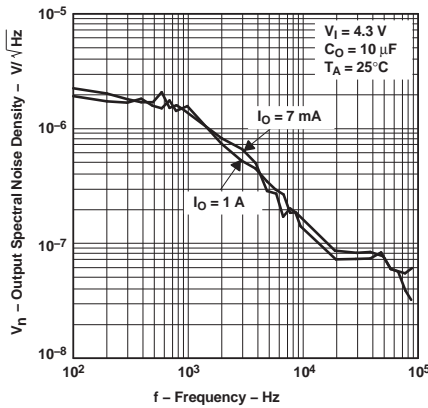

Figure 12.

OUTPUT IMPEDANCE
VS
FREQUENCY

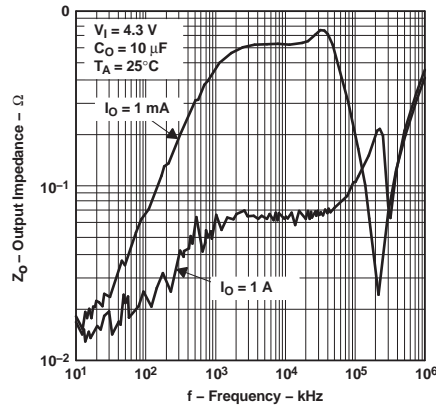

Figure 13.

DROPOUT VOLTAGE
VS
FREE-AIR TEMPERATURE

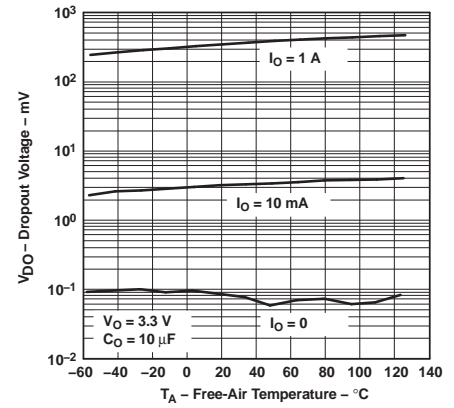

Figure 14.

LINE TRANSIENT RESPONSE

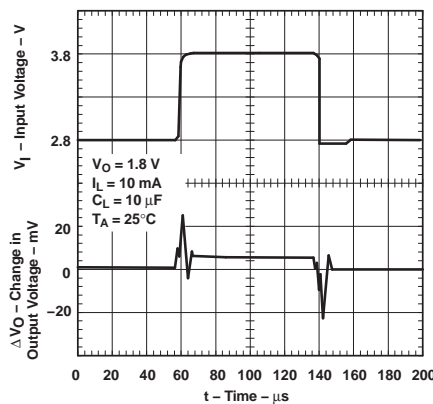

Figure 15.

LOAD TRANSIENT RESPONSE

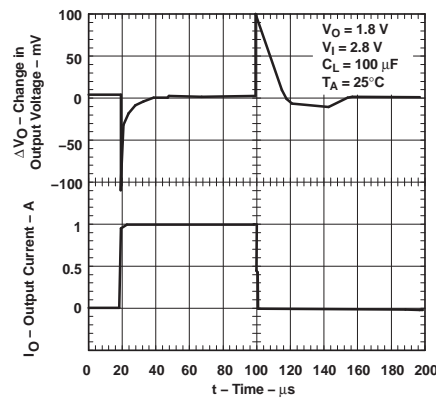

Figure 16.

LINE TRANSIENT RESPONSE

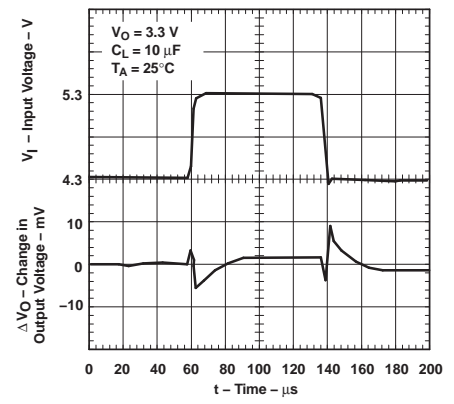

Figure 17.

TYPICAL CHARACTERISTICS (continued) (continued)

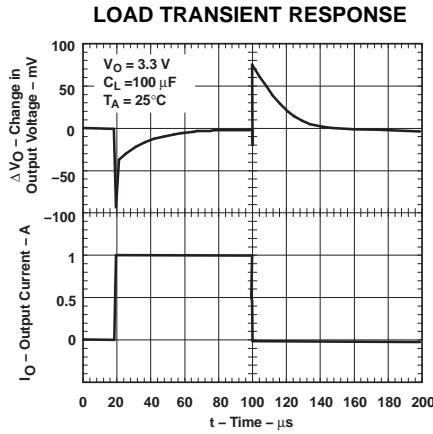

Figure 18.

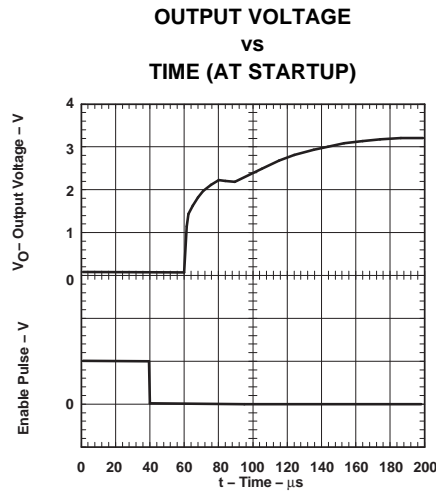

Figure 19.

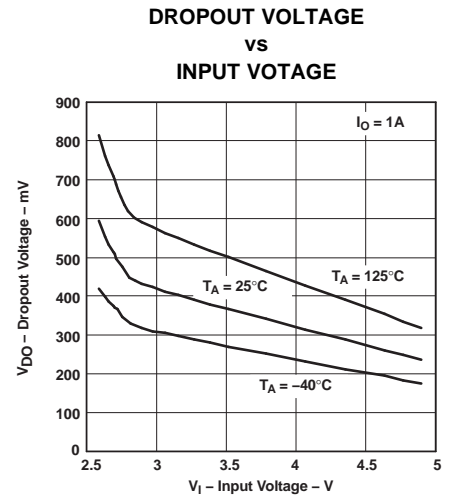

Figure 20.

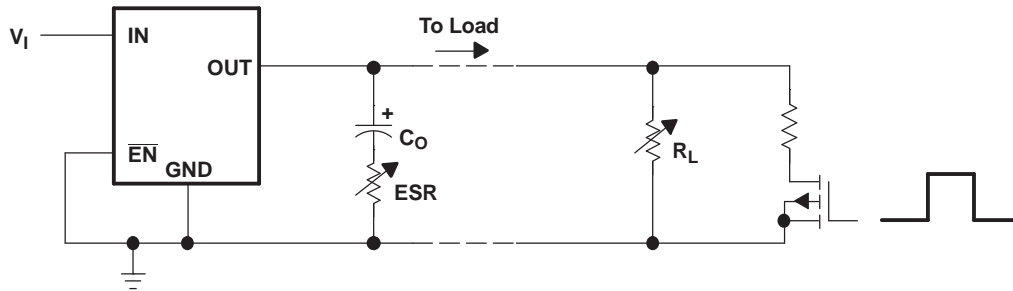
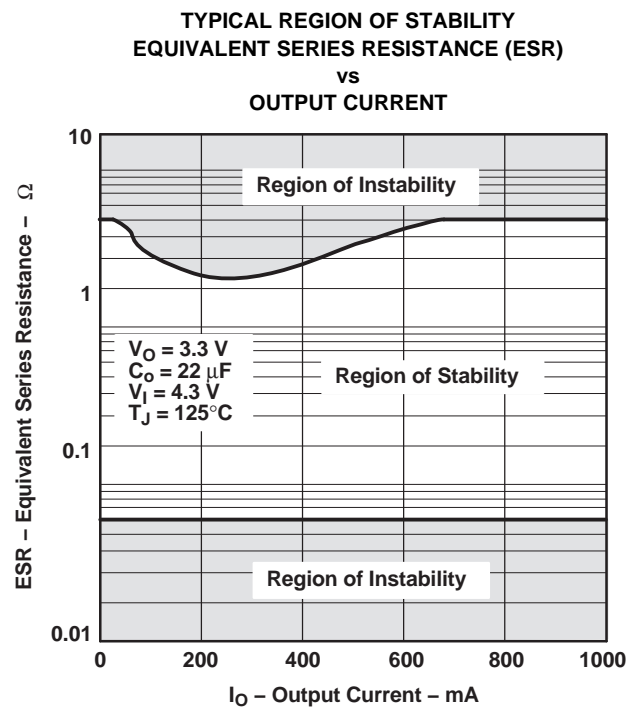
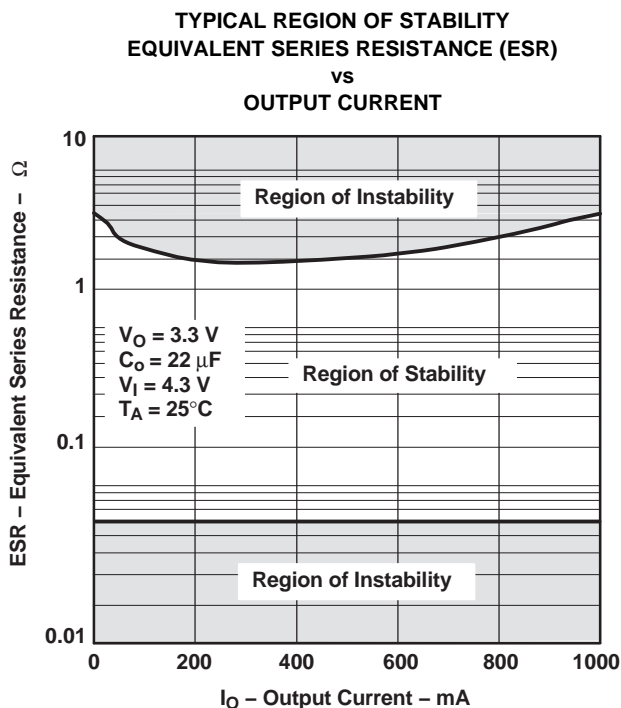
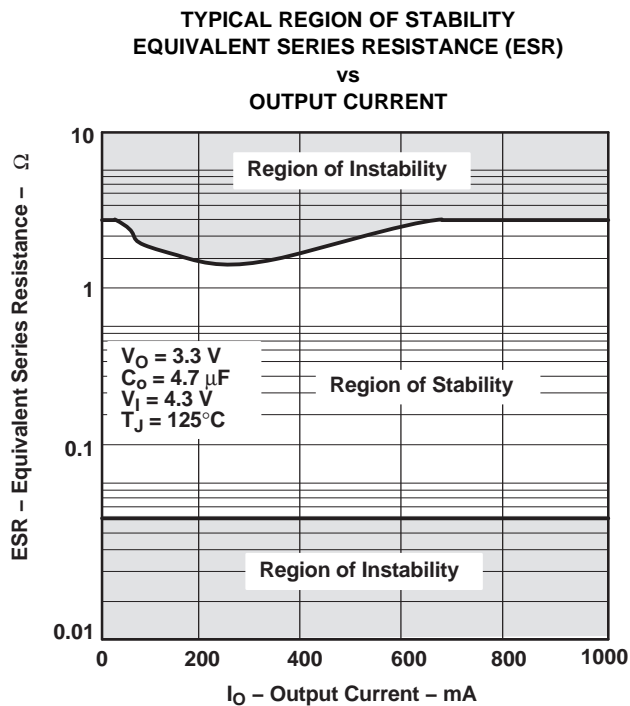
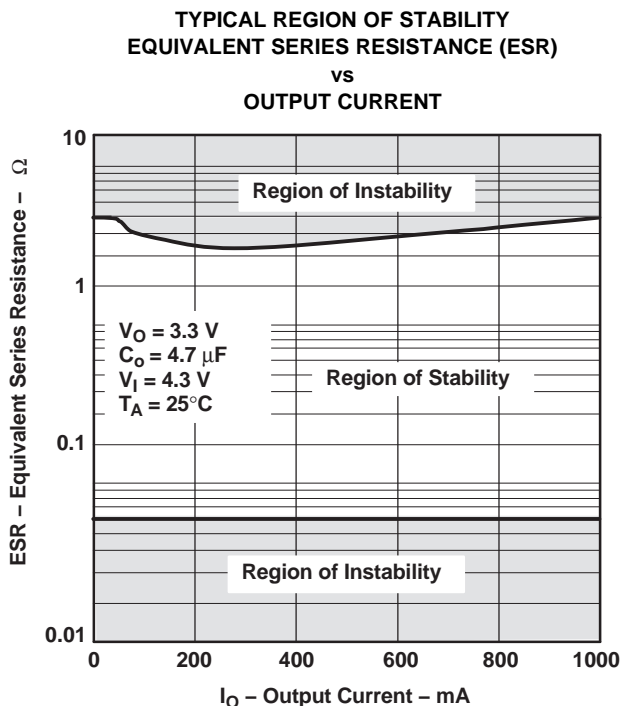

Figure 21. Test Circuit for Typical Regions of Stability (Figure 22 Through Figure 25) (Fixed-Output Options)

TYPICAL CHARACTERISTICS (continued)⁽¹⁾



(1) Equivalent series resistance (ESR) refers to the total series resistance, including the ESR of the capacitor, any series resistance added externally, and PWB trace resistance to C_O.

APPLICATION INFORMATION

The features of the TPS767D301-EP (low-dropout voltage, ultra-low quiescent current, power-saving shutdown mode, and a supply-voltage supervisor) and the power-dissipation properties of the TSSOP PowerPAD package have enabled the integration of the dual LDO regulator with high output current for use in DSP and other multiple-voltage applications.

Device Operation

The TPS767D301-EP features very low quiescent current, which remains virtually constant even with varying loads. Conventional LDO regulators use a pnp pass element, the base current of which is directly proportional to the load current through the regulator ($I_B = I_C/\beta$). Close examination of the data sheets reveals that these devices typically are specified under near no-load conditions; actual operating currents are much higher, as evidenced by typical quiescent current versus load current curves. The TPS767D301-EP uses a PMOS transistor to pass current; because the gate of the PMOS is voltage driven, operating current is low and invariable over the full load range. The TPS767D301-EP specifications reflect actual performance under load conditions.

Another pitfall associated with the pnp-pass element is its tendency to saturate when the device goes into dropout. The resulting drop in β forces an increase in I_B to maintain the load. During power up, this translates to large start-up currents. Systems with limited supply current may fail to start up. In battery-powered systems, it means rapid battery discharge when the voltage decays below the minimum required for regulation.

The TPS767D301-EP quiescent current remains low, even when the regulator drops out, eliminating both problems. The TPS767D301-EP also features a shutdown mode that places the output in the high-impedance state (essentially equal to the feedback-divider resistance) and reduces quiescent current to under 2 μ A. If the shutdown feature is not used, \overline{EN} should be tied to ground. Response to an enable transition is quick; regulated output voltage typically is reestablished in 120 μ s.

Minimum Load Requirements

The TPS767D301-EP is stable, even at zero load. No minimum load is required for operation.

FB – Pin Connection (Adjustable Version Only)

The FB pin is an input pin to sense the output voltage and close the loop for the adjustable option. The output voltage is sensed through a resistor divider network to close the loop (see [Figure 27](#)). Normally, this connection should be as short as possible; however, the connection can be made near a critical circuit to improve performance at that point. Internally, FB connects to a high-impedance wide-bandwidth amplifier, and noise pickup feeds through to the regulator output. Routing the FB connection to minimize/avoid noise pickup is essential. In fixed-output options, this pin is a no connect.

External Capacitor Requirements

An input capacitor is not required; however, a ceramic bypass capacitor (0.047 pF to 0.1 mF) improves load transient response and noise rejection when the TPS767D301-EP is located more than a few inches from the power supply. A higher-capacitance electrolytic capacitor may be necessary if large (hundreds of milliamps) load transients with fast rise times are anticipated.

Like all low dropout regulators, the TPS767D301-EP requires an output capacitor connected between OUT and GND to stabilize the internal control loop. The minimum recommended capacitance value is 10 μ F and the equivalent series resistance (ESR) must be between 60 m Ω and 1.5 Ω . Capacitor values of 10 μ F or larger are acceptable, provided the ESR is less than 1.5 Ω . Solid tantalum electrolytic, aluminum electrolytic, and multilayer ceramic capacitors are all suitable, provided they meet the requirements previously described.

When it is necessary to achieve low height requirements along with high output current and/or high ceramic load capacitance, several higher ESR capacitors can be used in parallel to meet the previous guidelines.

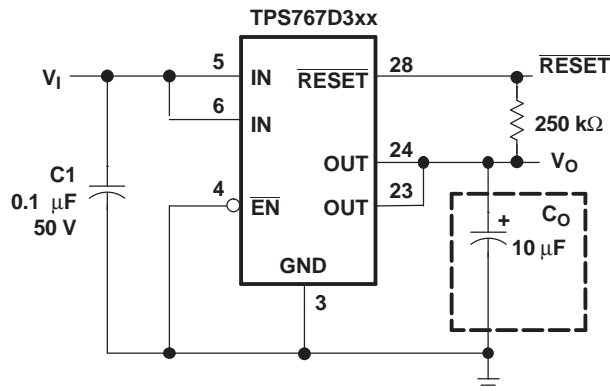

Figure 26. Typical Application Circuit (Fixed Versions) for Single Channel

Programming the TPS767D301-EP Adjustable LDO Regulator

The output voltage of the TPS767D301-EP adjustable regulator is programmed using an external resistor divider as shown in Figure 27. The output voltage is calculated using:

$$V_O = V_{ref} \times \left(1 + \frac{R1}{R2}\right)$$

where:

$$V_{ref} = 1.1834 \text{ V typ (the internal reference voltage)} \tag{1}$$

Resistors R1 and R2 should be chosen for approximately 50-μA divider current. Lower-value resistors can be used, but offer no inherent advantage and waste more power. Higher values should be avoided, as leakage currents at FB increase the output voltage error. The recommended design procedure is to choose R2 = 30.1 kΩ to set the divider current at 50 μA and then calculate R1 using:

$$R1 = \left(\frac{V_O}{V_{ref}} - 1\right) \times R2 \tag{2}$$

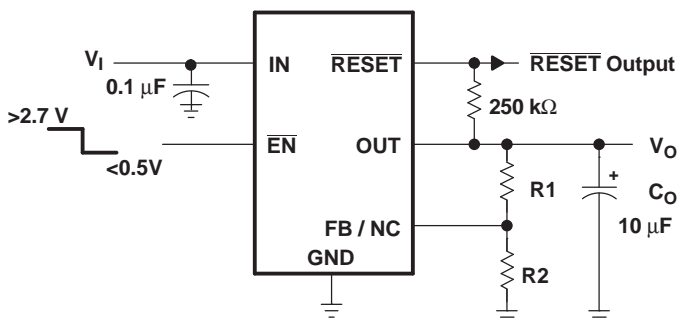

OUTPUT VOLTAGE PROGRAMMING GUIDE

OUTPUT VOLTAGE	R1	R2	UNIT
2.5 V	33.2	30.1	kΩ
3.3 V	53.6	30.1	kΩ
3.6 V	61.9	30.1	kΩ
4.75V	90.8	30.1	kΩ

Figure 27. TPS767D301-EP Adjustable LDO Regulator Programming

Reset Indicator

The TPS767D301-EP features a RESET output that can be used to monitor the status of the regulator. The internal comparator monitors the output voltage. When the output drops to 95% (typical) of its regulated value, the RESET output transistor turns on, taking the signal low. The open-drain output requires a pullup resistor. If not used, it can be left floating. RESET can be used to drive power-on reset circuitry or as a low-battery indicator.

Regulator Protection

The TPS767D301-EP PMOS-pass transistor has a built-in back-gate diode that safely conducts reverse currents when the input voltage drops below the output voltage (e.g., during power down). Current is conducted from the output to the input and is not internally limited. When extended reverse voltage is anticipated, external limiting may be appropriate.

The TPS767D301-EP also features internal current limiting and thermal protection. During normal operation, the TPS767D301-EP limits output current to approximately 1.7 A. When current limiting engages, the output voltage scales back linearly until the overcurrent condition ends. While current limiting is designed to prevent gross device failure, care should be taken not to exceed the power dissipation ratings of the package. If the temperature of the device exceeds 150°C (typ), thermal-protection circuitry shuts it down. Once the device has cooled below 130°C (typ), regulator operation resumes.

Power Dissipation and Junction Temperature

Specified regulator operation is assured to a junction temperature of 125°C; the maximum junction temperature should be restricted to 125°C under normal operating conditions. This restriction limits the power dissipation the regulator can handle in any given application. To ensure the junction temperature is within acceptable limits, calculate the maximum allowable dissipation, $P_{D(max)}$, and the actual dissipation, P_D , which must be less than or equal to $P_{D(max)}$.

The maximum power dissipation limit is determined using the following equation:

$$P_{D(max)} = \frac{T_{Jmax} - T_A}{R_{\theta JA}}$$

where:

T_{Jmax} is the maximum allowable junction temperature

$R_{\theta JA}$ is the thermal resistance junction-to-ambient for the package, i.e., 27.9°C/W for the 28-terminal PWP with no airflow.

T_A is the ambient temperature.

(3)

The regulator dissipation is calculated using:

$$P_D = (V_I - V_O) \times I_O$$

(4)

Power dissipation resulting from quiescent current is negligible. Excessive power dissipation triggers the thermal protection circuit.

PACKAGING INFORMATION

Orderable Device	Status ⁽¹⁾	Package Type	Package Drawing	Pins	Package Qty	Eco Plan ⁽²⁾	Lead/Ball Finish	MSL Peak Temp ⁽³⁾
TPS767D301MPWPREP	ACTIVE	HTSSOP	PWP	28	2000	Green (RoHS & no Sb/Br)	CU NIPDAU	Level-2-260C-1 YEAR
V62/06617-01XE	ACTIVE	HTSSOP	PWP	28	2000	Green (RoHS & no Sb/Br)	CU NIPDAU	Level-2-260C-1 YEAR

⁽¹⁾ The marketing status values are defined as follows:

ACTIVE: Product device recommended for new designs.

LIFEBUY: TI has announced that the device will be discontinued, and a lifetime-buy period is in effect.

NRND: Not recommended for new designs. Device is in production to support existing customers, but TI does not recommend using this part in a new design.

PREVIEW: Device has been announced but is not in production. Samples may or may not be available.

OBsolete: TI has discontinued the production of the device.

⁽²⁾ Eco Plan - The planned eco-friendly classification: Pb-Free (RoHS), Pb-Free (RoHS Exempt), or Green (RoHS & no Sb/Br) - please check <http://www.ti.com/productcontent> for the latest availability information and additional product content details.

TBD: The Pb-Free/Green conversion plan has not been defined.

Pb-Free (RoHS): TI's terms "Lead-Free" or "Pb-Free" mean semiconductor products that are compatible with the current RoHS requirements for all 6 substances, including the requirement that lead not exceed 0.1% by weight in homogeneous materials. Where designed to be soldered at high temperatures, TI Pb-Free products are suitable for use in specified lead-free processes.

Pb-Free (RoHS Exempt): This component has a RoHS exemption for either 1) lead-based flip-chip solder bumps used between the die and package, or 2) lead-based die adhesive used between the die and leadframe. The component is otherwise considered Pb-Free (RoHS compatible) as defined above.

Green (RoHS & no Sb/Br): TI defines "Green" to mean Pb-Free (RoHS compatible), and free of Bromine (Br) and Antimony (Sb) based flame retardants (Br or Sb do not exceed 0.1% by weight in homogeneous material)

⁽³⁾ MSL, Peak Temp. -- The Moisture Sensitivity Level rating according to the JEDEC industry standard classifications, and peak solder temperature.

Important Information and Disclaimer:The information provided on this page represents TI's knowledge and belief as of the date that it is provided. TI bases its knowledge and belief on information provided by third parties, and makes no representation or warranty as to the accuracy of such information. Efforts are underway to better integrate information from third parties. TI has taken and continues to take reasonable steps to provide representative and accurate information but may not have conducted destructive testing or chemical analysis on incoming materials and chemicals. TI and TI suppliers consider certain information to be proprietary, and thus CAS numbers and other limited information may not be available for release.

In no event shall TI's liability arising out of such information exceed the total purchase price of the TI part(s) at issue in this document sold by TI to Customer on an annual basis.

OTHER QUALIFIED VERSIONS OF TPS767D301-EP :

- Catalog: [TPS767D301](#)
- Automotive: [TPS767D301-Q1](#)

NOTE: Qualified Version Definitions:

- Catalog - TI's standard catalog product
- Automotive - Q100 devices qualified for high-reliability automotive applications targeting zero defects

TAPE AND REEL INFORMATION
REEL DIMENSIONS

TAPE DIMENSIONS

A0	Dimension designed to accommodate the component width
B0	Dimension designed to accommodate the component length
K0	Dimension designed to accommodate the component thickness
W	Overall width of the carrier tape
P1	Pitch between successive cavity centers

TAPE AND REEL INFORMATION

*All dimensions are nominal

Device	Package Type	Package Drawing	Pins	SPQ	Reel Diameter (mm)	Reel Width W1 (mm)	A0 (mm)	B0 (mm)	K0 (mm)	P1 (mm)	W (mm)	Pin1 Quadrant
TPS767D301MPWPREP	HTSSOP	PWP	28	2000	330.0	16.4	6.9	10.2	1.8	12.0	16.0	Q1

TAPE AND REEL BOX DIMENSIONS



*All dimensions are nominal

Device	Package Type	Package Drawing	Pins	SPQ	Length (mm)	Width (mm)	Height (mm)
TPS767D301MPWPREP	HTSSOP	PWP	28	2000	367.0	367.0	38.0

MECHANICAL DATA

PWP (R-PDSO-G28)

PowerPAD™ PLASTIC SMALL OUTLINE

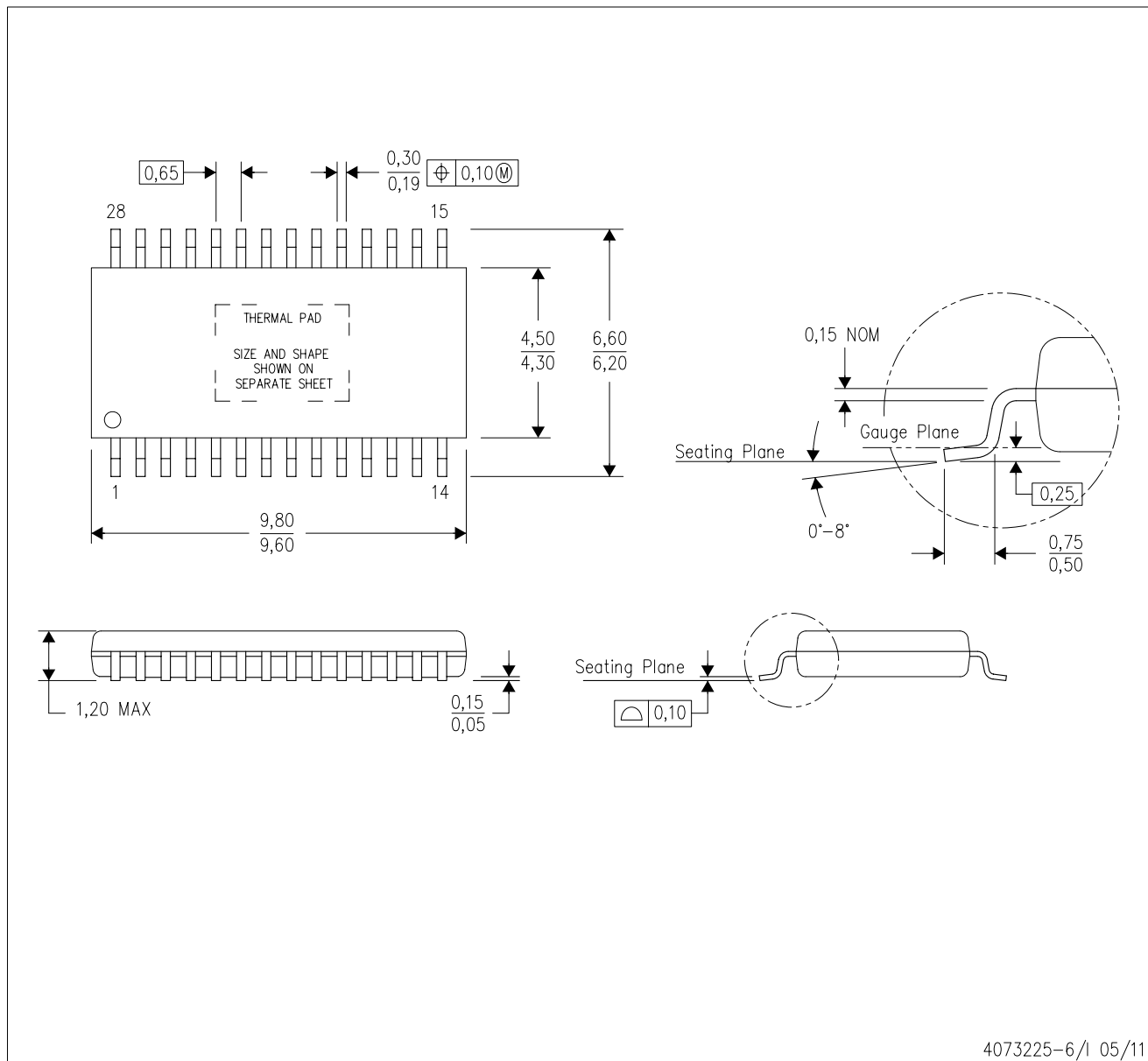

- NOTES:
- All linear dimensions are in millimeters.
 - This drawing is subject to change without notice.
 - Body dimensions do not include mold flash or protrusions. Mold flash and protrusion shall not exceed 0.15 per side.
 - This package is designed to be soldered to a thermal pad on the board. Refer to Technical Brief, PowerPad Thermally Enhanced Package, Texas Instruments Literature No. SLMA002 for information regarding recommended board layout. This document is available at www.ti.com <<http://www.ti.com>>.
 - See the additional figure in the Product Data Sheet for details regarding the exposed thermal pad features and dimensions.
 - Falls within JEDEC MO-153

PowerPAD is a trademark of Texas Instruments.

THERMAL PAD MECHANICAL DATA

PWP (R-PDSO-G28) PowerPAD™ SMALL PLASTIC OUTLINE

THERMAL INFORMATION

This PowerPAD™ package incorporates an exposed thermal pad that is designed to be attached to a printed circuit board (PCB). The thermal pad must be soldered directly to the PCB. After soldering, the PCB can be used as a heatsink. In addition, through the use of thermal vias, the thermal pad can be attached directly to the appropriate copper plane shown in the electrical schematic for the device, or alternatively, can be attached to a special heatsink structure designed into the PCB. This design optimizes the heat transfer from the integrated circuit (IC).

For additional information on the PowerPAD package and how to take advantage of its heat dissipating abilities, refer to Technical Brief, PowerPAD Thermally Enhanced Package, Texas Instruments Literature No. SLMA002 and Application Brief, PowerPAD Made Easy, Texas Instruments Literature No. SLMA004. Both documents are available at www.ti.com.

The exposed thermal pad dimensions for this package are shown in the following illustration.

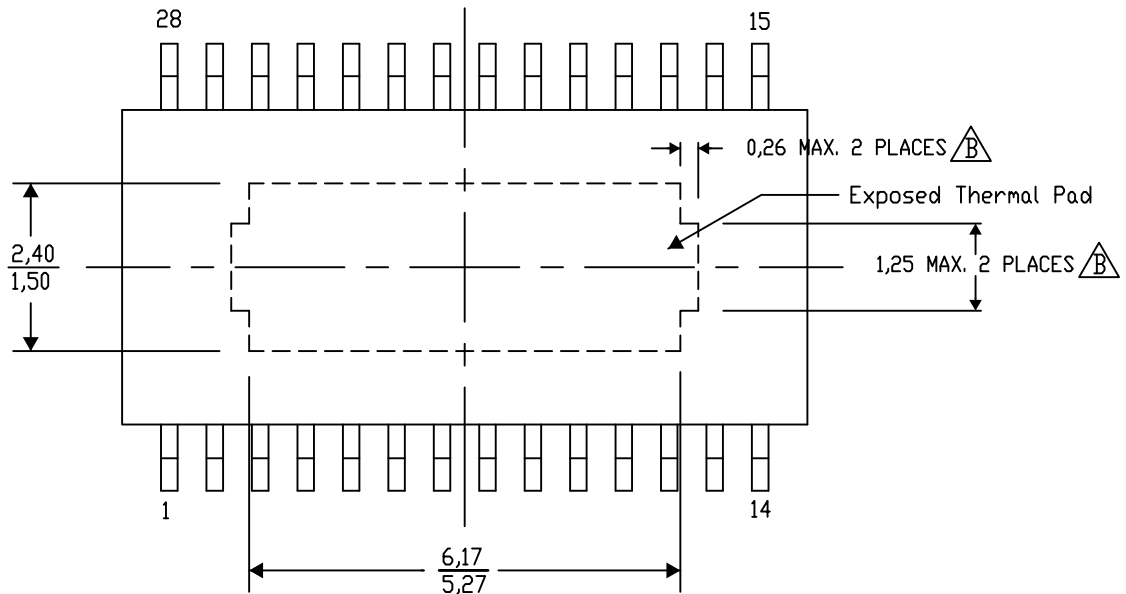

Top View

Exposed Thermal Pad Dimensions

4206332-33/AC 07/12

NOTE: A. All linear dimensions are in millimeters
 $\triangle B$. Exposed tie strap features may not be present.

PowerPAD is a trademark of Texas Instruments

PWP (R-PDSO-G28)

PowerPAD™ PLASTIC SMALL OUTLINE

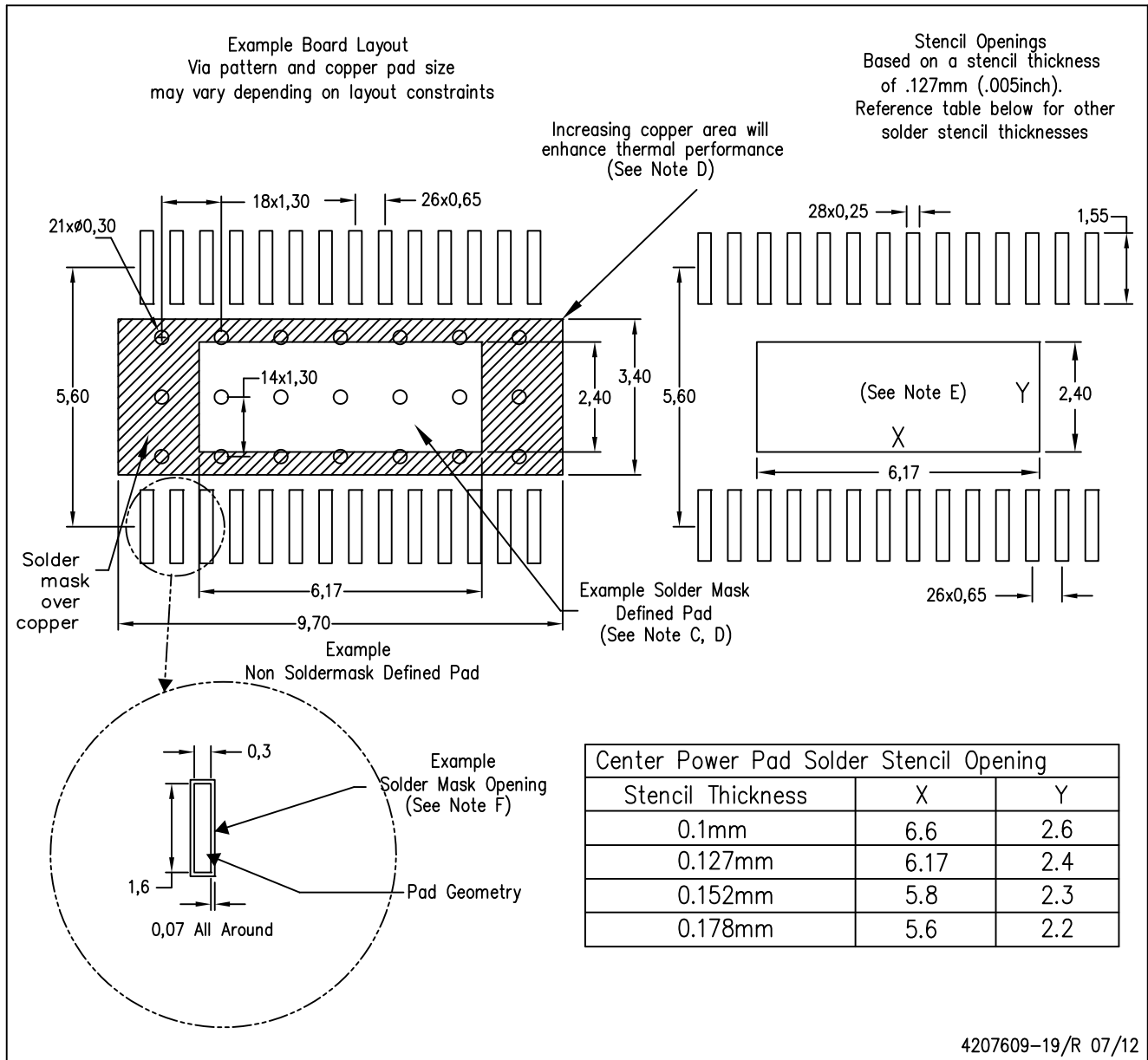

- NOTES:
- All linear dimensions are in millimeters.
 - This drawing is subject to change without notice.
 - Customers should place a note on the circuit board fabrication drawing not to alter the center solder mask defined pad.
 - This package is designed to be soldered to a thermal pad on the board. Refer to Technical Brief, PowerPad Thermally Enhanced Package, Texas Instruments Literature No. SLMA002, SLMA004, and also the Product Data Sheets.
 - For specific thermal information, via requirements, and recommended board layout. These documents are available at www.ti.com <<http://www.ti.com>>. Publication IPC-7351 is recommended for alternate designs. Laser cutting apertures with trapezoidal walls and also rounding corners will offer better paste release. Customers should contact their board assembly site for stencil design recommendations. Example stencil design based on a 50% volumetric metal load solder paste. Refer to IPC-7525 for other stencil
 - Customers should contact their board fabrication site for solder mask tolerances between and around signal pads.

IMPORTANT NOTICE

Texas Instruments Incorporated and its subsidiaries (TI) reserve the right to make corrections, enhancements, improvements and other changes to its semiconductor products and services per JESD46C and to discontinue any product or service per JESD48B. Buyers should obtain the latest relevant information before placing orders and should verify that such information is current and complete. All semiconductor products (also referred to herein as "components") are sold subject to TI's terms and conditions of sale supplied at the time of order acknowledgment.

TI warrants performance of its components to the specifications applicable at the time of sale, in accordance with the warranty in TI's terms and conditions of sale of semiconductor products. Testing and other quality control techniques are used to the extent TI deems necessary to support this warranty. Except where mandated by applicable law, testing of all parameters of each component is not necessarily performed.

TI assumes no liability for applications assistance or the design of Buyers' products. Buyers are responsible for their products and applications using TI components. To minimize the risks associated with Buyers' products and applications, Buyers should provide adequate design and operating safeguards.

TI does not warrant or represent that any license, either express or implied, is granted under any patent right, copyright, mask work right, or other intellectual property right relating to any combination, machine, or process in which TI components or services are used. Information published by TI regarding third-party products or services does not constitute a license to use such products or services or a warranty or endorsement thereof. Use of such information may require a license from a third party under the patents or other intellectual property of the third party, or a license from TI under the patents or other intellectual property of TI.

Reproduction of significant portions of TI information in TI data books or data sheets is permissible only if reproduction is without alteration and is accompanied by all associated warranties, conditions, limitations, and notices. TI is not responsible or liable for such altered documentation. Information of third parties may be subject to additional restrictions.

Resale of TI components or services with statements different from or beyond the parameters stated by TI for that component or service voids all express and any implied warranties for the associated TI component or service and is an unfair and deceptive business practice. TI is not responsible or liable for any such statements.

Buyer acknowledges and agrees that it is solely responsible for compliance with all legal, regulatory and safety-related requirements concerning its products, and any use of TI components in its applications, notwithstanding any applications-related information or support that may be provided by TI. Buyer represents and agrees that it has all the necessary expertise to create and implement safeguards which anticipate dangerous consequences of failures, monitor failures and their consequences, lessen the likelihood of failures that might cause harm and take appropriate remedial actions. Buyer will fully indemnify TI and its representatives against any damages arising out of the use of any TI components in safety-critical applications.

In some cases, TI components may be promoted specifically to facilitate safety-related applications. With such components, TI's goal is to help enable customers to design and create their own end-product solutions that meet applicable functional safety standards and requirements. Nonetheless, such components are subject to these terms.

No TI components are authorized for use in FDA Class III (or similar life-critical medical equipment) unless authorized officers of the parties have executed a special agreement specifically governing such use.

Only those TI components which TI has specifically designated as military grade or "enhanced plastic" are designed and intended for use in military/aerospace applications or environments. Buyer acknowledges and agrees that any military or aerospace use of TI components which have **not** been so designated is solely at the Buyer's risk, and that Buyer is solely responsible for compliance with all legal and regulatory requirements in connection with such use.

TI has specifically designated certain components which meet ISO/TS16949 requirements, mainly for automotive use. Components which have not been so designated are neither designed nor intended for automotive use; and TI will not be responsible for any failure of such components to meet such requirements.

Products

Audio	www.ti.com/audio
Amplifiers	amplifier.ti.com
Data Converters	dataconverter.ti.com
DLP® Products	www.dlp.com
DSP	dsp.ti.com
Clocks and Timers	www.ti.com/clocks
Interface	interface.ti.com
Logic	logic.ti.com
Power Mgmt	power.ti.com
Microcontrollers	microcontroller.ti.com
RFID	www.ti-rfid.com
OMAP Mobile Processors	www.ti.com/omap
Wireless Connectivity	www.ti.com/wirelessconnectivity

Applications

Automotive and Transportation	www.ti.com/automotive
Communications and Telecom	www.ti.com/communications
Computers and Peripherals	www.ti.com/computers
Consumer Electronics	www.ti.com/consumer-apps
Energy and Lighting	www.ti.com/energy
Industrial	www.ti.com/industrial
Medical	www.ti.com/medical
Security	www.ti.com/security
Space, Avionics and Defense	www.ti.com/space-avionics-defense
Video and Imaging	www.ti.com/video

TI E2E Community e2e.ti.com