

TPS65295 complete DDR4 memory power solution

1 Features

- Synchronous buck converter (VDDQ)
 - Input voltage range: 4.5 V to 18 V
 - Output voltage fixed at 1.2 V
 - D-CAP3™ mode control for fast transient response
 - Continual output current: 8 A
 - Advanced Eco-mode™ pulse skip
 - Integrated 22-mΩ and 8.6-mΩ $R_{DS(on)}$ internal power switch
 - 600-kHz switching frequency
 - Internal soft start: 1.6 ms
 - Cycle-by-cycle overcurrent protection
 - Latched output OV and UV protections
- Synchronous buck converter (VPP)
 - Input voltage range: 3 V to 5.5 V
 - Output voltage fixed at 2.5 V
 - D-CAP3™ mode control for fast transient response
 - Continual output current: 1 A
 - Advanced Eco-mode™ pulse skip
 - Integrated 150-mΩ and 120-mΩ $R_{DS(on)}$ internal power switch
 - 580-kHz switching frequency
 - Internal soft start: 1 ms
 - Cycle-by-cycle overcurrent protection
 - Latched output OV and UV protections
- 1-A LDO (VTT)
 - 1-A continual sink and source current
 - Requires only 10 μF of ceramic output capacitor
 - Support high-z in S3
 - ±30-mV VTT output accuracy (DC+AC)
- Buffered reference (VTTREF)
 - Buffered, low noise, ±10-mA capability
 - 0.8% output accuracy
- Low quiescent current: 150 μA
- Power good indicator
- Output discharge function
- Power up and power down sequencing control
- Non-latch for OT and UVLO protections
- 18-pin 3.0-mm × 3.0-mm HotRod™ VQFN package

2 Applications

- DDR4 memory power supplies
- Notebook, PC computers, and servers
- Ultrabook, tablet computers
- Single-board computer, computer on module

3 Description

The TPS65295 device provides a complete power solution for DDR4 memory system with the lowest total cost and minimum space. It meets the JEDEC standard for DDR4 power-up and power-down sequence requirement. The TPS65295 integrates two synchronous buck converters (VPP and VDDQ) and a 1-A sink and source tracking LDO (VTT) and a buffered low noise reference (VTTREF). The TPS65295 employs D-CAP3™ mode coupled with 600-kHz switching frequency for ease-of-use, fast transient, and support for ceramic output capacitors without an external compensation circuit.

The VTTREF tracks $\frac{1}{2}$ VDDQ within excellent 0.8% accuracy. The VTT, which provides both 1-A sink and source continual current capabilities, requires only 10-μF of ceramic output capacitor.

The TPS65295 provides rich functions as well as excellent power supply performance. It supports flexible power state control, placing VTT at high-Z in S3 and discharging VDDQ, VTT, and VTTREF in S4/S5 state. OVP, UVP, OCP, UVLO and thermal shutdown protections are also available. The part is available in a thermally enhanced 18-pin HotRod™ VQFN package and is designed to operate under the –40°C to 125°C junction temperature range.

Device Information⁽¹⁾

PART NUMBER	PACKAGE	BODY SIZE (NOM)
TPS65295	VQFN (18)	3.00 mm × 3.00 mm

(1) For all available packages, see the orderable addendum at the end of the data sheet.

Typical Application

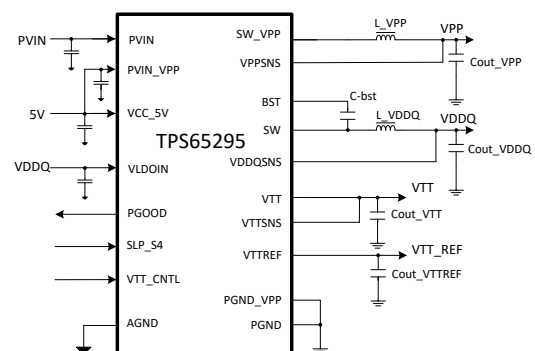

Table of Contents

1 Features	1	8 Application and Implementation	18
2 Applications	1	8.1 Application Information.....	18
3 Description	1	8.2 Typical Application	18
4 Revision History	2	9 Power Supply Recommendations	25
5 Pin Configuration and Functions	3	10 Layout	26
6 Specifications	4	10.1 Layout Guidelines	26
6.1 Absolute Maximum Ratings	4	10.2 Layout Example	26
6.2 ESD Ratings	4	11 Device and Documentation Support	27
6.3 Recommended Operating Conditions.....	4	11.1 Device Support	27
6.4 Thermal Information	5	11.2 Receiving Notification of Documentation Updates	27
6.5 Electrical Characteristics.....	5	11.3 Community Resources.....	27
6.6 Typical Characteristics.....	8	11.4 Trademarks	27
7 Detailed Description	13	11.5 Electrostatic Discharge Caution.....	27
7.1 Overview	13	11.6 Glossary	27
7.2 Functional Block Diagram	14	12 Mechanical, Packaging, and Orderable	
7.3 Feature Description.....	15	Information	27
7.4 Device Functional Modes.....	17	12.1 Package Option Addendum	28

4 Revision History

NOTE: Page numbers for previous revisions may differ from page numbers in the current version.

DATE	REVISION	NOTES
February 2019	*	Initial release.

5 Pin Configuration and Functions

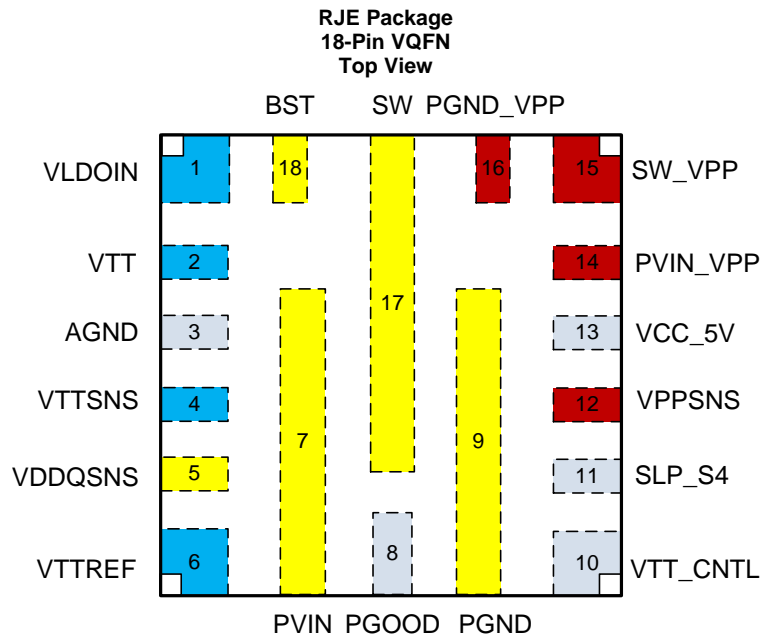

Pin Functions

PIN		I/O	DESCRIPTION
NAME	NO.		
VLDOIN	1	P	Power supply input for VTT LDO. Connect VDDQ in typical application.
VTT	2	O	VTT 1-A LDO output. Recommend to connect to 10- μ F or larger capacitance for stability.
AGND	3	G	Signal ground.
VTTSNS	4	I	VTT output voltage feedback.
VDDQSNS	5	I	VDDQ output voltage feedback.
VTTREF	6	O	Buffered VTT reference output. Recommend to connect to 0.22- μ F or larger capacitance for stability.
PVIN	7	P	Input power supply for VDDQ buck.
PGOOD	8	O	Power good signal open-drain output. PGOOD goes high when VPP and VDDQ output voltage are within the target range.
PGND	9	G	Power ground for VDDQ buck.
VTT_CNTL	10	I	VTT_CNTL signal input for VTT LDO enable control. For detail control setup, please refer to Table 1 .
SLP_S4	11	I	SLP_S4 signal input for VDDQ buck and VPP buck enable control. For detail control setup, please refer to Table 1 .
VPPSNS	12	I	VPP output voltage feedback.
VCC_5V	13	P	Power supply for VPP and VDDQ buck converter control logic circuit.
PVIN_VPP	14	P	Input power supply for VPP buck.
SW_VPP	15	O	VPP switching node connection to the inductor and bootstrap capacitor.
PGND_VPP	16	G	Power ground for VPP buck.
SW	17	O	VDDQ switching node connection to the inductor and bootstrap capacitor.
BST	18	I	High-side MOSFET gate driver bootstrap voltage input for VDDQ buck. Connect a capacitor between the BST pin and the SW pin.

6 Specifications

6.1 Absolute Maximum Ratings

 over operating free-air temperature range (unless otherwise noted) ⁽¹⁾

		MIN	MAX	UNIT
Input voltage	PVIN	-0.3	20	V
	VBST	-0.3	25	V
	VBST-SW	-0.3	6	V
	VTT_CNTL, SLP_S4, VCC_5V, PVIN_VPP, VLDOIN, VDDQSNS, VTTSNS, VPPSNS	-0.3	6	V
	PGND, AGND, PGND_VPP	-0.3	0.3	V
Output voltage	SW DC	-0.3	20	V
	SW (20-ns transient)	-3	22	V
	SW_VPP DC	-0.3	7	V
	SW_VPP (20-ns transient)	-3	8	V
	PGOOD, VTT, VTTREF	-0.3	6	V
T _J	Operating junction temperature	-40	150	°C
T _{stg}	Storage temperature	-55	150	°C

- (1) Stresses beyond those listed under *Absolute Maximum Ratings* may cause permanent damage to the device. These are stress ratings only, which do not imply functional operation of the device at these or any other conditions beyond those indicated under *Recommended Operating Conditions*. Exposure to absolute-maximum-rated conditions for extended periods may affect device reliability.

6.2 ESD Ratings

		VALUE	UNIT	
V _(ESD)	Electrostatic discharge	Human-body model (HBM), per ANSI/ESDA/JEDEC JS-001 ⁽¹⁾	±2000	V
		Charged-device model (CDM), per JEDEC specification JESD22- V C101 ⁽²⁾	±500	V

- (1) JEDEC document JEP155 states that 500-V HBM allows safe manufacturing with a standard ESD control process.
 (2) JEDEC document JEP157 states that 250-V CDM allows safe manufacturing with a standard ESD control process.

6.3 Recommended Operating Conditions

over operating free-air temperature range (unless otherwise noted)

		MIN	MAX	UNIT
Input voltage	PVIN	4.5	18	V
	VBST	-0.3	23	V
	VBST-SW	-0.3	5.5	V
	VTT_CNTL, SLP_S4, VCC_5V, PVIN_VPP, VLDOIN, VDDQSNS, VTTSNS, VPPSNS	-0.3	5.5	V
	PGND, AGND, PGND_VPP	-0.3	0.3	V
Output voltage	SW DC	-0.3	18	V
	SW (20-ns transient)	-3	20	V
	SW_VPP DC	-0.3	5.5	V
	SW_VPP (20-ns transient)	-3	6.5	V
	PGOOD, VTT, VTTREF	-0.3	5.5	V
I _{VDDQOUT}	VDDQ Output current		8	A
T _J	Operating junction temperature	-40	125	°C

6.4 Thermal Information

THERMAL METRIC ⁽¹⁾		TPS65295	UNIT
		RJE (VQFN)	
		18 PINS	
R _{θJA}	Junction-to-ambient thermal resistance	58.1	°C/W
R _{θJC(top)}	Junction-to-case (top) thermal resistance	26.1	°C/W
R _{θJB}	Junction-to-board thermal resistance	17.7	°C/W
ψ _{JT}	Junction-to-top characterization parameter	0.5	°C/W
ψ _{JB}	Junction-to-board characterization parameter	17.7	°C/W
R _{θJC(bot)}	Junction-to-case (bottom) thermal resistance	N/A	°C/W

(1) For more information about traditional and new thermal metrics, see the [IC Package Thermal Metrics](#) application report.

6.5 Electrical Characteristics

T_J = -40°C to 125°C, V_{PVIN} = 12V, V_{PVIN_VPP} = 5V (unless otherwise noted)

PARAMETER	TEST CONDITIONS	MIN	TYP	MAX	UNIT
INPUT SUPPLY VOLTAGE					
I _{VCC_5V}	V _{S4} = V _{VTT_CNTL} = 0 V		5		μA
	V _{S4} = 5 V, V _{VTT_CNTL} = 0 V, no load		110		μA
	V _{S4} = V _{VTT_CNTL} = 5 V, no load		150		μA
V _{IN}	PVIN input voltage range	4.5		18	V
UVLO					
UVLO	Wake up VCC_5V voltage		4.1	4.5	V
	Shut down VCC_5V voltage	3.3	3.6		V
	Hysteresis VCC_5V voltage		500		mV
VDDQ					
V _{VDDQSNS}	VDDQ sense voltage	1.188	1.2	1.212	V
I _{VDDQSNS}	VDDQSNS input current		40		μA
I _{VDDQDIS}	VDDQ discharge current		12		mA
t _{VDDQSS}	VDDQ soft-start time		1.6	2.65	ms
t _{VDDQDLY}	VDDQ ramp up delay time		2		ms
R _{DSONH}	High-side switch resistance		22		mΩ
R _{DSONL}	Low-side switch resistance		8.6		mΩ
I _{VDDQOCL}	Low-side valley current limited	8.2	9.8	11.5	A
f _{sw}	VDDQ switching frequency		600		kHz
t _{OFF(MIN)}	Minimum off time		198		ns
PGOOD (VDDQ, VPP)					
V _{THPG}	VDDQSNS / VPPSNS falling (Fault)		87		%
	VDDQSNS / VPPSNS rising (Good)		93		%
	VDDQSNS / VPPSNS rising (Fault)		115		%
	VDDQSNS / VPPSNS falling (Good)		110		%
I _{PGMAX}	PG sink current		46		mA
t _{PGDLY}	PG start-up delay		1		ms
VPP					
V _{VPPSNS}	VPP sense voltage	2.45	2.5	2.55	V
I _{VPPSNS}	VPPSNS input current		20		μA

Electrical Characteristics (continued)
 $T_J = -40^{\circ}\text{C}$ to 125°C , $V_{PVIN} = 12\text{V}$, $V_{PVIN_VPP} = 5\text{V}$ (unless otherwise noted)

PARAMETER	TEST CONDITIONS	MIN	TYP	MAX	UNIT		
I_{VPPDIS}	VPP discharge current	$V_{SLP_S4} = V_{VTT_CNTL} = 0\text{V}$, $V_{VPPSNS} = 0.5\text{V}$		12	mA		
t_{VPPSS}	VPP soft-start time		1.0	2	ms		
R_{DSONH}	High-side switch resistance	$T_J = 25^{\circ}\text{C}$, $V_{PVIN_VPP} = 5\text{V}$, $V_{VCC_5V} = 5\text{V}$		150	$\text{m}\Omega$		
R_{DSONL}	Low-side switch resistance	$T_J = 25^{\circ}\text{C}$, $V_{PVIN_VPP} = 5\text{V}$, $V_{VCC_5V} = 5\text{V}$		120	$\text{m}\Omega$		
I_{VPOCL}	Low-side valley current limited	$V_{OUT} = 2.5\text{V}$, $L = 4.7\ \mu\text{H}$		1.05	A		
f_{sw}	VPP switching frequency		580		kHz		
$t_{OFF(MIN)}$	Minimum off time		195		ns		
t_{OOA}	OOA mode operation period	$V_{VPPSNS} = 2.5\text{V}$		31	μs		
OVP AND UVP (VDDQ, VPP)							
V_{OVP}	OVP threshold voltage	OVP detect voltage		120	125	130	%
V_{UVP1}	UVP threshold voltage	UVP detect voltage		55	60	65	%
t_{OVLDY}	OVP delay		20				μs
t_{UVLDY}	UVP delay		250				μs
VTTREF OUTPUT							
V_{VTTREF}	Output voltage			$1/2^* V_{VDDQSNS}$			V
V_{VTTREF}	Output voltage tolerance to VDDQ	$T_J = 25^{\circ}\text{C}$, $ I_{VTTREF} \leq 100\ \mu\text{A}$, $V_{VDDQSNS} = 1.2\text{V}$		49.2		50.8	%
		$T_J = 25^{\circ}\text{C}$, $ I_{VTTREF} \leq 10\text{mA}$, $V_{VDDQSNS} = 1.2\text{V}$		49		51	
$I_{VTTREFOCLSRC}$	Source current limit	$V_{VDDQSNS} = 1.2\text{V}$, $V_{VTTREF} = 0\text{V}$		10	18		mA
$I_{VTTREFOCLSNk}$	Sink current limit	$V_{VDDQSNS} = 1.2\text{V}$, $V_{VTTREF} = 1.2\text{V}$		10	18		mA
$I_{VTTREFDIS}$	VTTREF discharge current	$T_J = 25^{\circ}\text{C}$, $V_{SLP_S4} = V_{VTT_CNTL} = 0\text{V}$, $V_{VTTREF} = 0.5\text{V}$		0.8	1.3		mA
VTT OUTPUT							
V_{VTT}	Output voltage			V_{VTTREF}			V
V_{VTTTOL}	Output voltage tolerance	$ I_{VTT} \leq 10\text{mA}$, $V_{VDDQSNS} = 1.2\text{V}$, $I_{VTTREF} = 0\text{A}$		-20		20	mV
		$T_J = 25^{\circ}\text{C}$, $ I_{VTT} \leq 1\text{A}$, $V_{VDDQSNS} = 1.2\text{V}$, $I_{VTTREF} = 0\text{A}$		-30		30	
$I_{VTTOCLSRC}$	Source current limit	$V_{VDDQSNS} = 1.2\text{V}$, $V_{VTT} = V_{VTTNS} = 0.5\text{V}$, $I_{VTTREF} = 0\text{A}$		1	1.7		A
$I_{VTTOCLSNk}$	Sink current limit	$V_{VDDQSNS} = 1.2\text{V}$, $V_{VTT} = V_{VTTNS} = 0.7\text{V}$, $I_{VTTREF} = 0\text{A}$		1	1.7		A
I_{VTTLK}	Leakage current	$T_J = 25^{\circ}\text{C}$, $V_{SLP_S4} = 5\text{V}$, $V_{VTT_CNTL} = 5\text{V}$, $V_{VTT} = V_{VTTREF}$				5	μA
$I_{VTTNSBIAS}$	VTTNS input bias current	$V_{SLP_S4} = 5\text{V}$, $V_{VTT_CNTL} = 5\text{V}$, $V_{VTT} = V_{VTTREF}$		-0.5	0	0.5	
$I_{VTTNSLK}$	VTTNS leakage current	$V_{SLP_S4} = 5\text{V}$, $V_{VTT_CNTL} = 0\text{V}$, $V_{VTT} = V_{VTTREF}$		-1	0	1	
I_{VTTDLY}	VTT output delay relative to VTT_CNTL					35	us
I_{VTTDIS}	VTT discharge current	$T_J = 25^{\circ}\text{C}$, $V_{SLP_S4} = V_{VTT_CNTL} = 0\text{V}$, $V_{VDDQSNS} = 1.2\text{V}$, $V_{VTT} = 0.5\text{V}$, $I_{VTTREF} = 0\text{A}$			5.7		mA
SLP_S4, VTT_CNTL LOGIC THRESHOLD							
V_{IH}	SLP_S4/VTT_CNTL high-level voltage		1.6				V

Electrical Characteristics (continued)
 $T_J = -40^{\circ}\text{C}$ to 125°C , $V_{PVIN} = 12\text{V}$, $V_{PVIN_VPP} = 5\text{V}$ (unless otherwise noted)

PARAMETER		TEST CONDITIONS	MIN	TYP	MAX	UNIT
V_{IL}	SLP_S4/VTT_CNTL low-level voltage				0.5	V
R_{TOGND}	SLP_S4/VTT_CNTL resistance to GND			500		$k\Omega$
THERMAL PROTECTION						
T_{OTP}	OTP trip threshold			150		$^{\circ}\text{C}$
T_{OTPHSY}	OTP hysteresis			20		$^{\circ}\text{C}$

6.6 Typical Characteristics

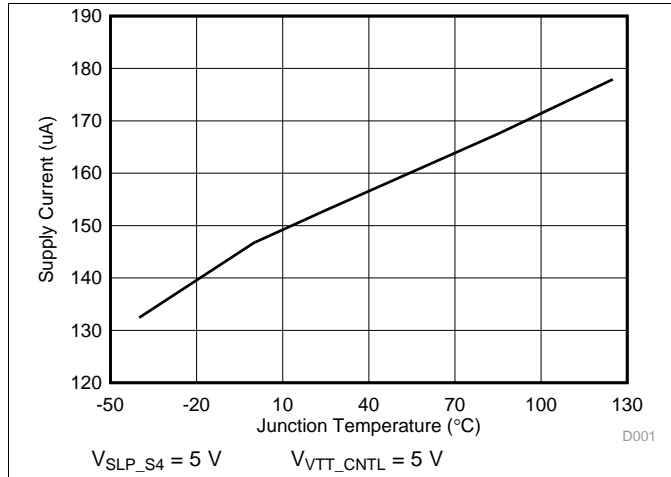

Figure 1. VCC_5V Supply Current vs Junction Temperature

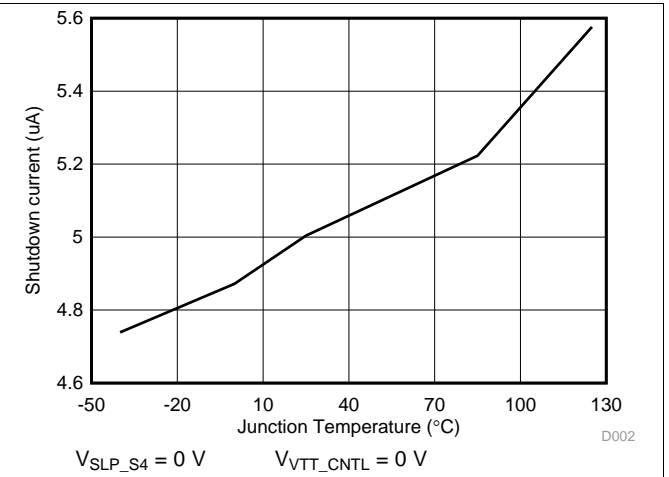

Figure 2. VCC_5V Shutdown Current vs Temperature

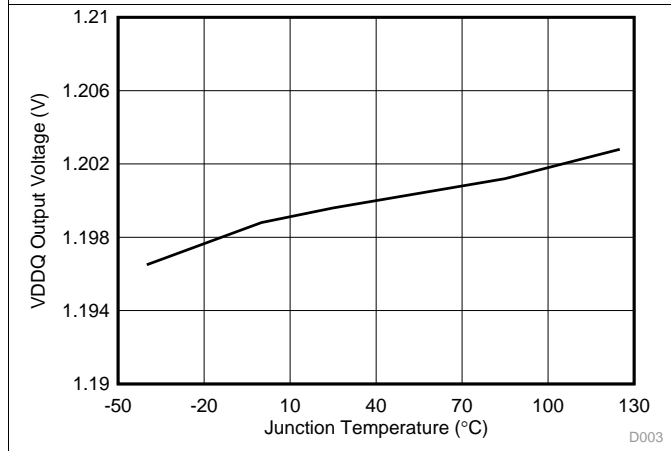

Figure 3. VDDQ Output Voltage vs Junction Temperature

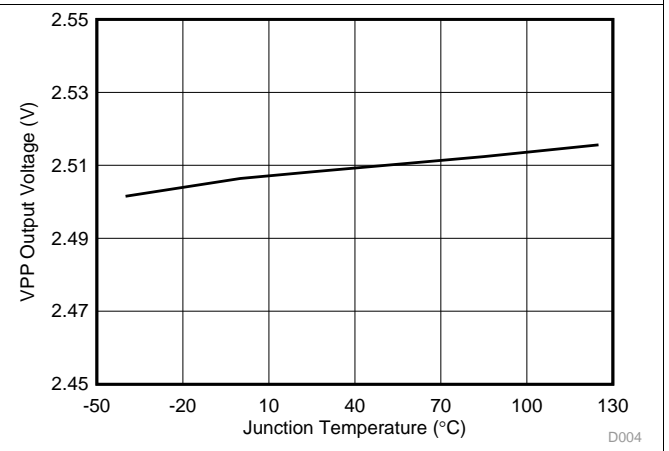

Figure 4. VPP Output Voltage vs Junction Temperature

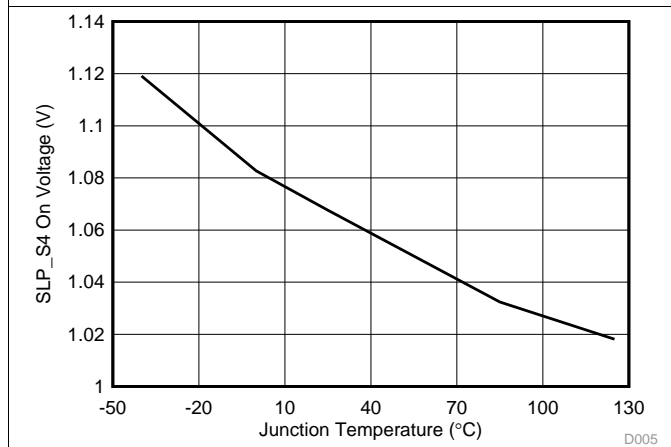

Figure 5. Enable On Voltage (SLP_S4) vs Junction Temperature

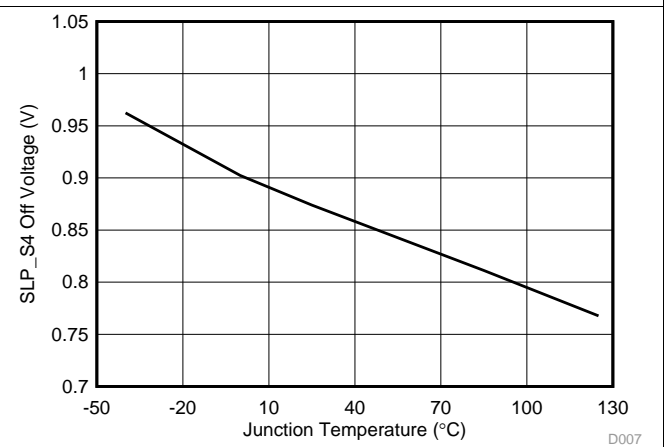

Figure 6. Enable Off Voltage (SLP_S4) vs Junction Temperature

Typical Characteristics (continued)

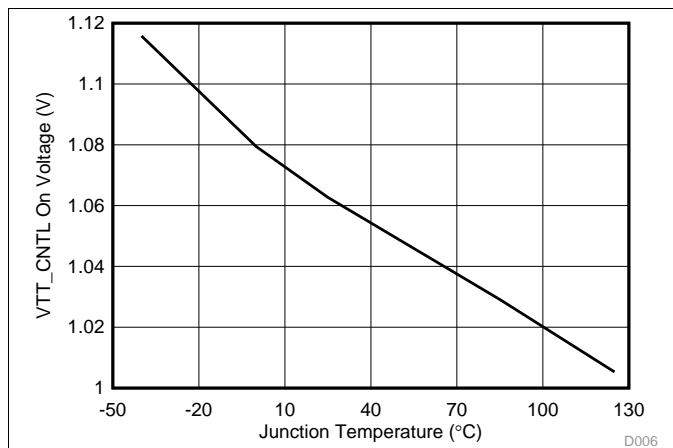

Figure 7. Enable On Voltage (VTT_CNTL) vs Junction Temperature

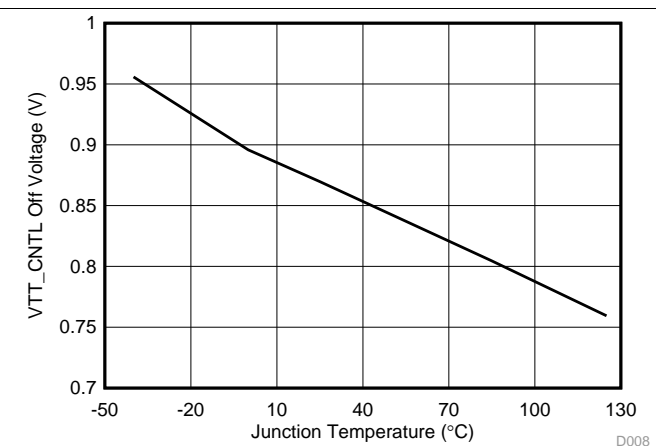

Figure 8. Enable Off Voltage (VTT_CNTL) vs Junction Temperature

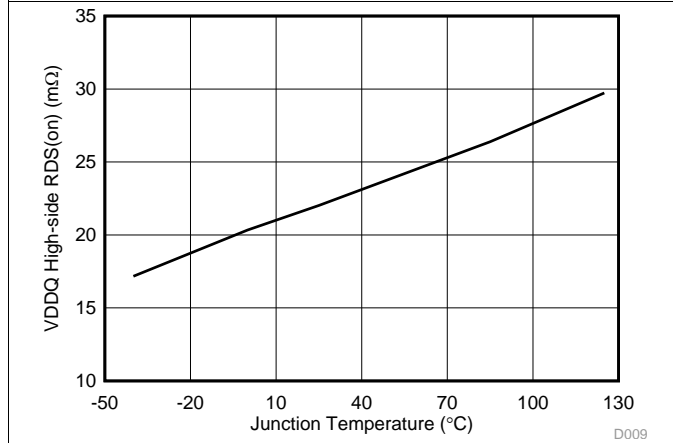

Figure 9. VDDQ High-Side R_DS(on) vs Junction Temperature

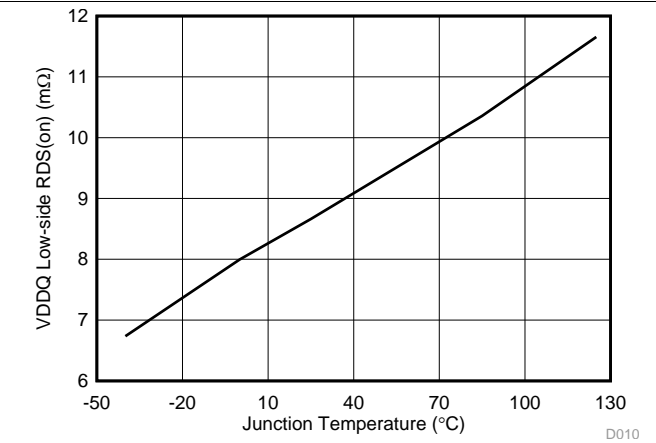

Figure 10. VDDQ Low-Side R_DS(on) vs Junction Temperature

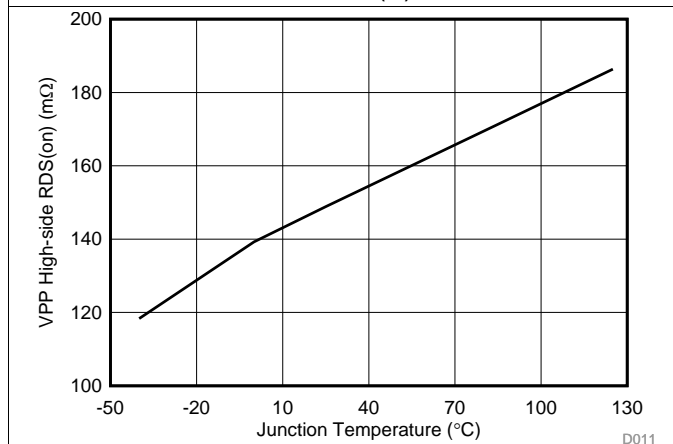

Figure 11. VPP High-Side R_DS(on) vs Junction Temperature

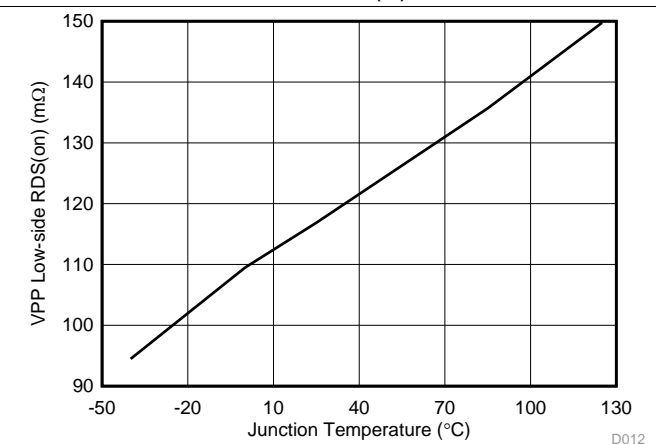

Figure 12. VPP Low-Side R_DS(on) vs Junction Temperature

Typical Characteristics (continued)

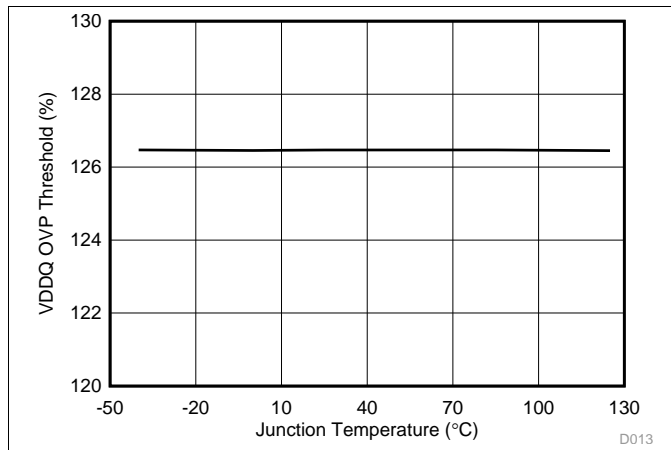

Figure 13. VDDQ OVP Threshold vs Junction Temperature

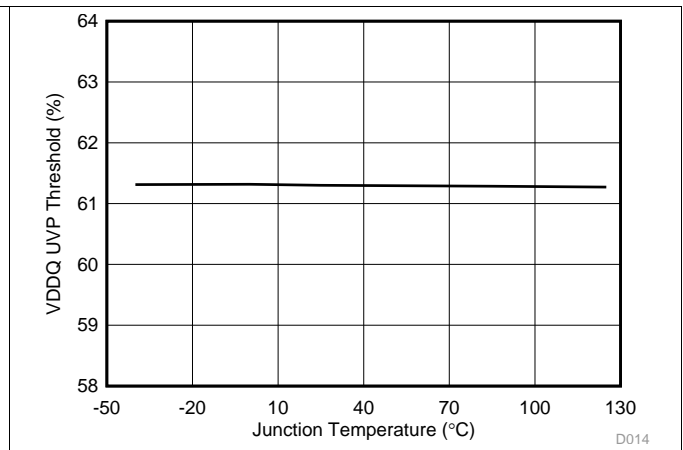

Figure 14. VDDQ UVP Threshold vs Junction Temperature

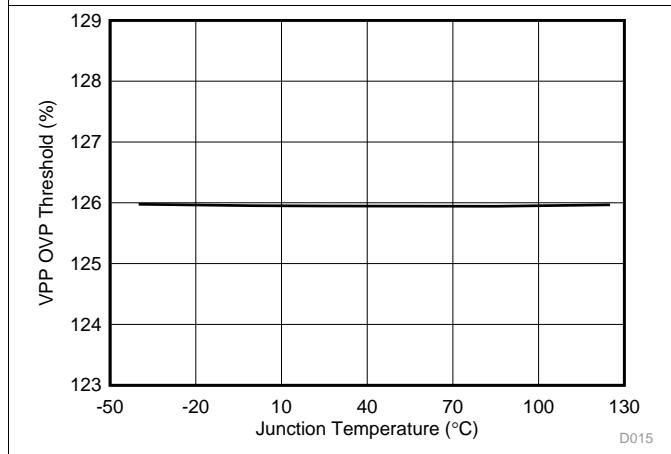

Figure 15. VPP OVP Threshold vs Junction Temperature

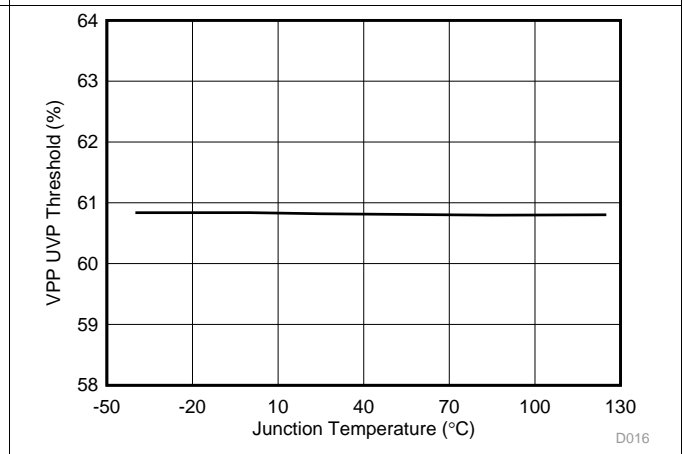

Figure 16. VPP UVP Threshold vs Junction Temperature

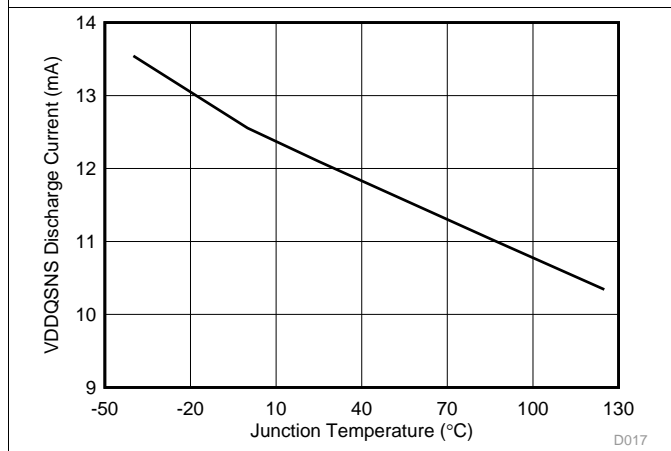

Figure 17. VDDQSNS Discharge Current vs Junction Temperature

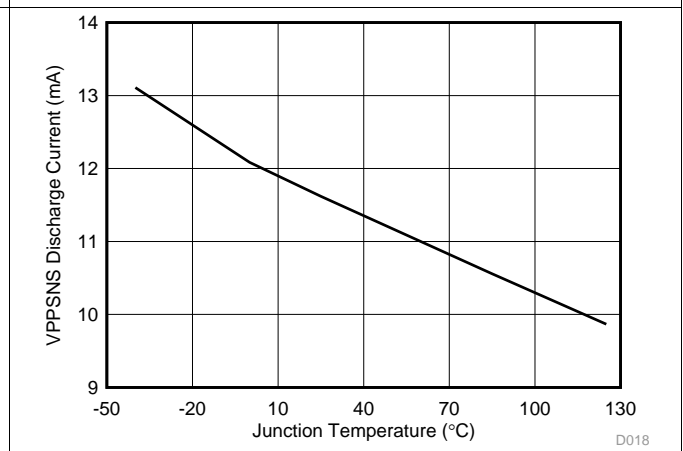

Figure 18. VPPSNS Discharge Current vs Junction Temperature

Typical Characteristics (continued)

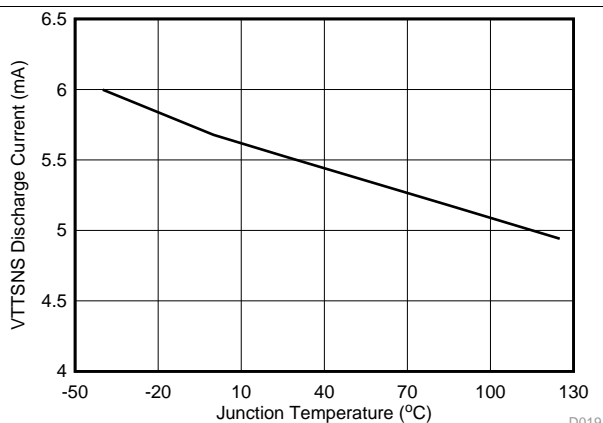

Figure 19. VTTSENS Discharge Current vs Junction Temperature

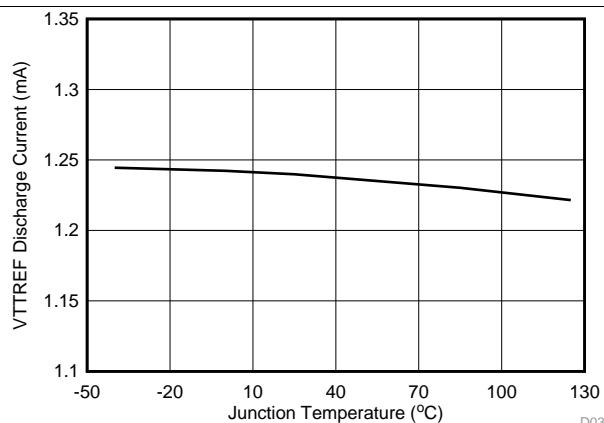

Figure 20. VTTREF Discharge Current vs Junction Temperature

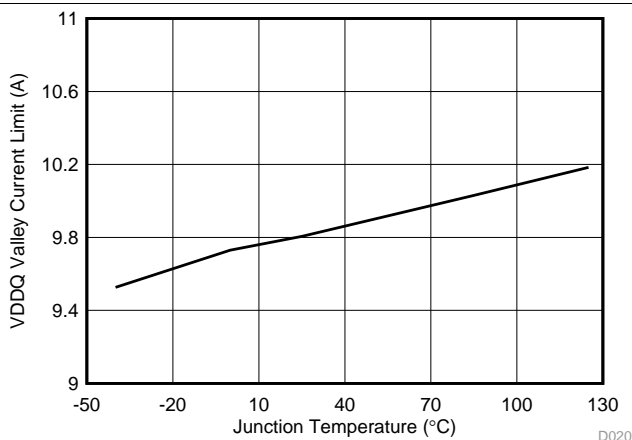

Figure 21. VDDQ Valley Current Limit vs Junction Temperature

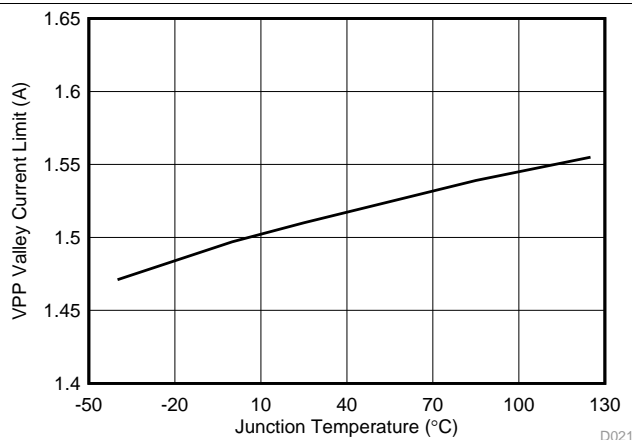

Figure 22. VPP Valley Current Limit vs Junction Temperature

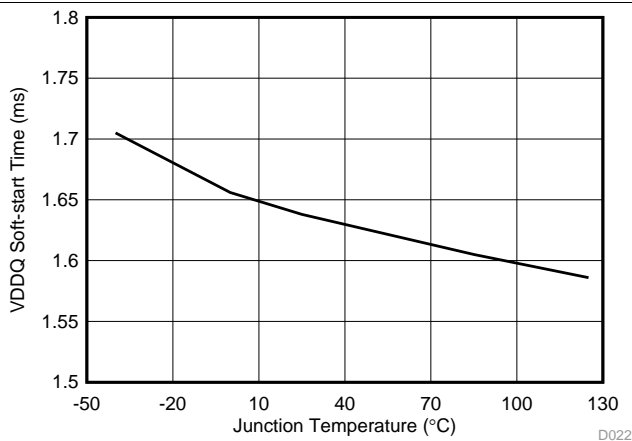

Figure 23. VDDQ Soft-Start Time vs Junction Temperature

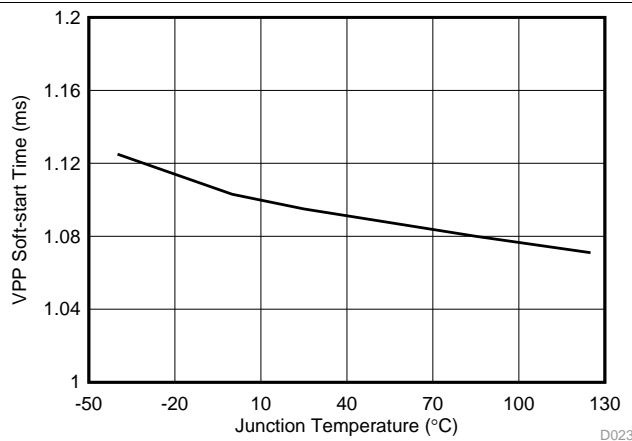

Figure 24. VPP Soft-Start Time vs Junction Temperature

Typical Characteristics (continued)

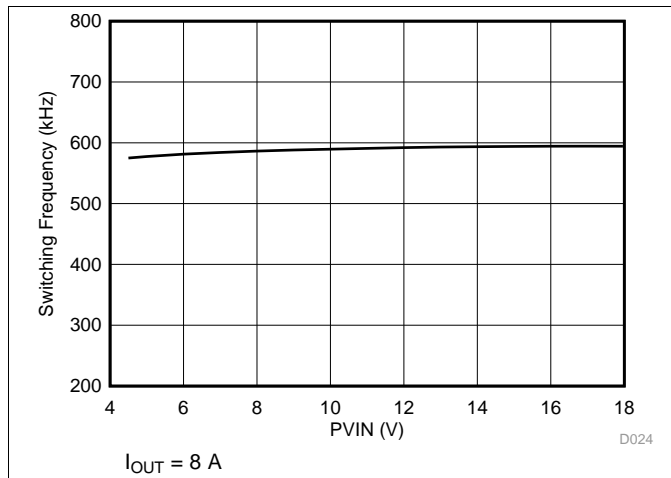

Figure 25. VDDQ Switching Frequency vs Input Voltage

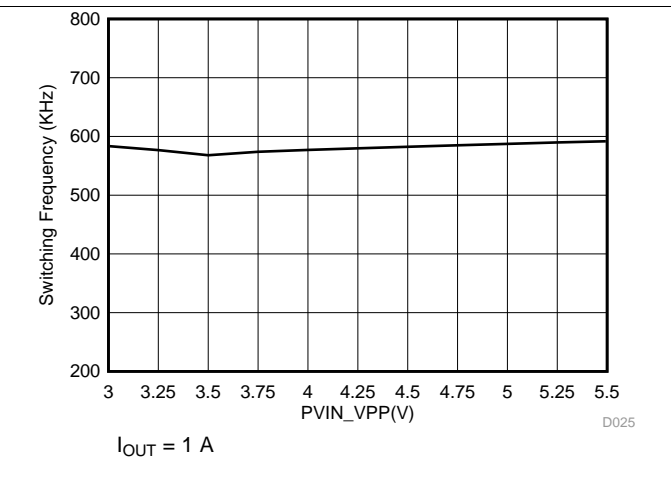

Figure 26. VPP Switching Frequency vs Input Voltage

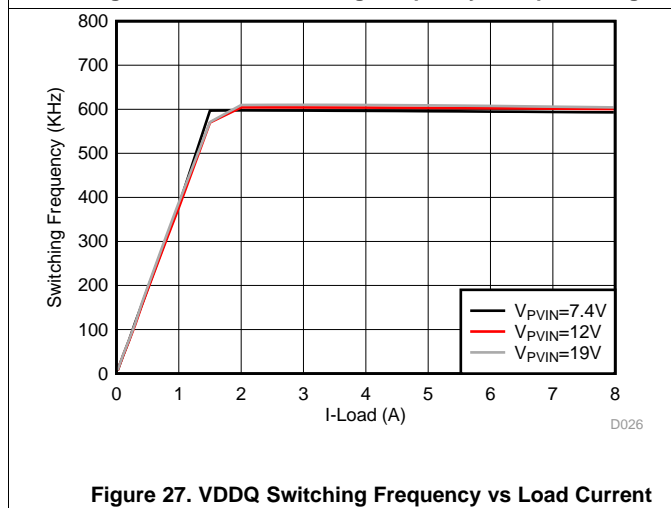

Figure 27. VDDQ Switching Frequency vs Load Current

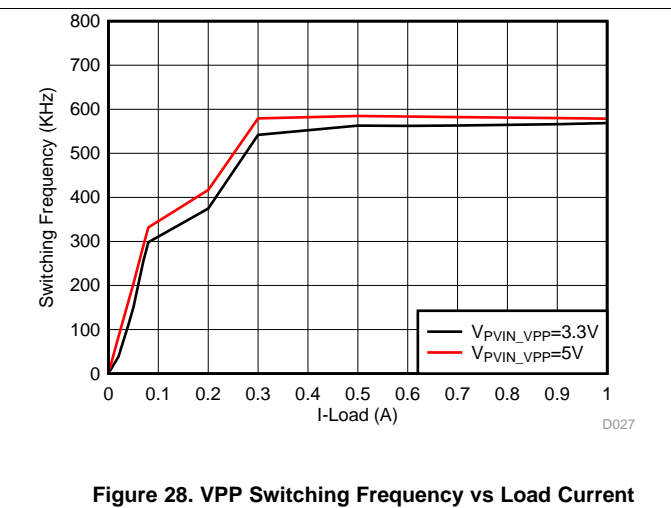

Figure 28. VPP Switching Frequency vs Load Current

7 Detailed Description

7.1 Overview

The TPS65295 integrates two synchronous step-down buck converters and two LDOs to support complete DDR4 power solution. The VDDQ buck converter has the fixed 1.2-V output and supports continuous 8-A output current, and it can operate from 4.5-V to 18-V PVIN input voltage. The VPP buck converter has the fixed 2.5-V output and supports continuous 1-A output current, and can operate from 3-V to 5.5-V PVIN_VPP input voltage. The VTTREF LDO tracks the $\frac{1}{2}$ VDDQ output and has about 10-mA both sink and source current capability. The VTT LDO tracks the VTTREF output and has continuous 1-A both sink and source current capability.

7.2 Functional Block Diagram

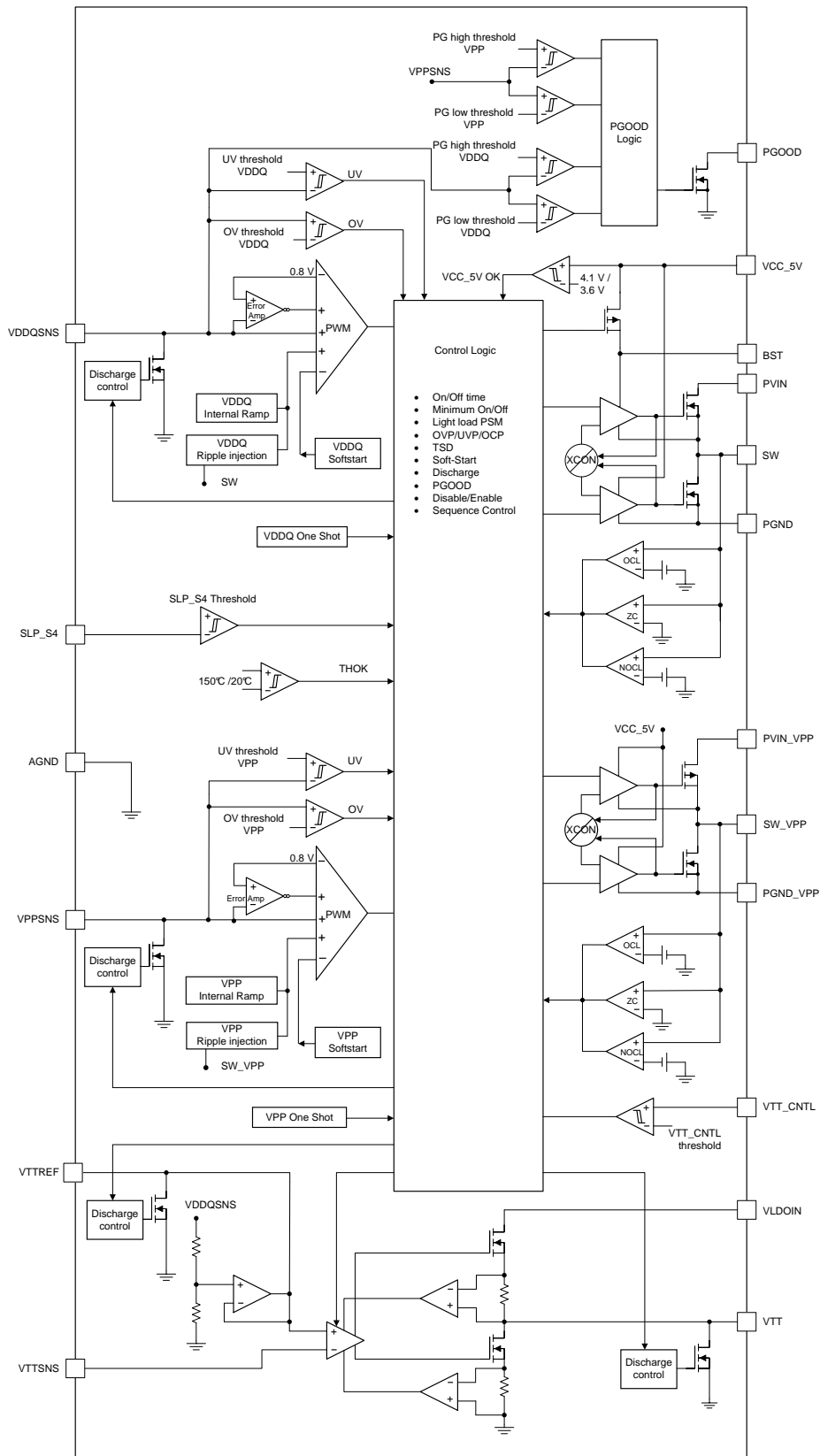

7.3 Feature Description

7.3.1 PWM Operation and D-CAP3™ Control

The main control loop of the two bucks is adaptive on-time pulse width modulation (PWM) controller that supports a proprietary DCAP3™ mode control. The DCAP3™ mode control combines adaptive on-time control with an internal compensation circuit for pseudo-fixed frequency and low external component count configuration with both low-ESR and ceramic output capacitors. It is stable even with virtually no ripple at the output. The TPS65295 also includes an error amplifier that makes the output voltage very accurate.

At the beginning of each cycle, the high-side MOSFET is turned on. This MOSFET is turned off after internal one-shot timer expires. This one-shot duration is set proportional to the converter input voltage, V_{IN} , and is inversely proportional to the output voltage, V_O , to maintain a pseudo-fixed frequency over the input voltage range, hence it is called adaptive on-time control. The one-shot timer is reset and the high-side MOSFET is turned on again when the feedback voltage falls below the reference voltage. An internal ripple generation circuit is added to reference voltage for emulating the output ripple, this enables the use of very low-ESR output capacitors such as multi-layered ceramic caps (MLCC). No external current sense network or loop compensation is required for DCAP3™ control topology.

Both VDDQ buck and VPP buck include an error amplifier that makes the output voltage very accurate. For any control topology that is compensated internally, there is a range of the output filter it can support. The output filter used with the TPS65295 is a low-pass L-C circuit. This L-C filter has a double-pole frequency described in [Equation 1](#).

$$f_P = \frac{1}{2 \times \pi \times \sqrt{L_{OUT} \times C_{OUT}}} \quad (1)$$

At low frequencies, the overall loop gain is set by the internal output set-point resistor divider network and the internal gain of the TPS65295. The low-frequency L-C double pole has a 180 degree in phase. At the output filter frequency, the gain rolls off at a -40 dB per decade rate and the phase drops rapidly. The internal ripple generation network introduces a high-frequency zero that reduces the gain roll off from -40 dB to -20 dB per decade and increases the phase to 90 degree one decade above the zero frequency. The internal ripple injection high-frequency zero is related to the switching frequency. The inductor and capacitor selected for the output filter must be such that the double pole is placed close enough to the high-frequency zero, so that the phase boost provided by this high-frequency zero provides adequate phase margin for the stability requirement. The crossover frequency of the overall system should usually be targeted to be less than one-fifth of the switching frequency (F_{SW}).

7.3.2 Advanced Eco-mode™ Control

The VDDQ buck and VPP buck are designed with advanced Eco-mode™ control schemes to maintain high light load efficiency. As the output current decreases from heavy load conditions, the inductor current is also reduced and eventually comes to a point where the rippled valley touches zero level, which is the boundary between continuous conduction and discontinuous conduction modes. The rectifying MOSFET is turned off when the zero inductor current is detected. As the load current further decreases, the converter runs into discontinuous conduction mode. The on-time is kept almost the same as it was in the continuous conduction mode, so that it takes longer time to discharge the output capacitor with smaller load current to the level of the reference voltage. This makes the switching frequency lower, proportional to the load current, and keeps the light load efficiency high. The light load current where the transition to Eco-mode™ operation happens ($I_{OUT(LL)}$) can be calculated from [Equation 2](#).

$$I_{OUT(LL)} = \frac{1}{2 \times L_{OUT} \times F_{SW}} \times \frac{(V_{IN} - V_{OUT}) \times V_{OUT}}{V_{IN}} \quad (2)$$

After identifying the application requirements, design the output inductance (L_{OUT}) so that the inductor peak-to-peak ripple current is approximately between 20% and 30% of the $I_{OUT(max)}$ (peak current in the application). It is also important to size the inductor properly so that the valley current does not hit the negative low-side current limit.

Feature Description (continued)

7.3.3 Soft Start and Prebiased Soft Start

The VDDQ buck has an internal 1.6-ms soft start and VPP buck has an internal 1-ms soft start. Provide the voltage supply to PVIN, PVIN_VPP and VCC_5V before asserting SLP_S4 to be high, when the SLP_S4 pin becomes high, the internal soft-start function begins ramping up the reference voltage to the PWM comparator.

If the output capacitor is prebiased at start-up, the devices initiate switching and start ramping up only after the internal reference voltage becomes greater than the feedback voltage. This scheme ensures that the converters ramp up smoothly into regulation point.

7.3.4 Power Good

The Power Good (PGOOD) pin is an open-drain output. Once the VDDQSNS and VPPSNS pins voltage are between 90% and 110% of the target output voltage, the PGOOD is deasserted and floats after a 1-ms de-glitch time. A pullup resistor of 100 k Ω is recommended to pull the voltage up to VCC_5V. The PGOOD pin is pulled low when:

- the VDDQSNS pin voltage or VPPSNS pin voltage is lower than 85% or greater than 115% of the target output voltage
- in an OVP, UVP, or thermal shutdown event
- during the soft-start period.

7.3.5 Overcurrent Protection and Undervoltage Protection

Both VDDQ and VPP bucks have the overcurrent protection and undervoltage protection, and the implementation is same. The output overcurrent limit (OCL) is implemented using a cycle-by-cycle valley detect control circuit. The switch current is monitored during the OFF state by measuring the low-side FET drain to source voltage. This voltage is proportional to the switch current. To improve accuracy, the voltage sensing is temperature compensated.

During the on-time of the high-side FET switch, the switch current increases at a linear rate determined by V_{in} , V_{out} , the on-time and the output inductor value. During the on-time of the low-side FET switch, this current decreases linearly. The average value of the switch current is the load current I_{OUT} . If the monitored current is above the OCL level, the converter maintains low-side FET on and delays the creation of a new set pulse, even the voltage feedback loop requires one, until the current level becomes OCL level or lower. In subsequent switching cycles, the on-time is set to a fixed value and the current is monitored in the same manner.

There are some important considerations for this type of overcurrent protection. When the load current is higher than the overcurrent threshold by one half of the peak-to-peak inductor ripple current, the OCL is triggered and the current is being limited, the output voltage tends to drop because the load demand is higher than what the converter can support. When the output voltage falls below 60% of the target voltage, the UVP comparator detects it, the output will be discharged and latched after a wait time of 256 μ s. When the overcurrent condition is removed, the output voltage is latched till the SLP_S4 is toggled or repower the VCC_5V power input.

7.3.6 Overvoltage Protection

Both VDDQ and VPP bucks have the overvoltage protection feature and have the same implementation. When the output voltage becomes higher than 125% of the target voltage, the OVP comparator output goes high, and then the output will be discharged and latched after a wait time of 20 μ s. When the over current condition is removed, the output voltage is latched till the SLP_S4 is toggled or repower the VCC_5V power input.

7.3.7 UVLO Protection

Undervoltage Lockout protection (UVLO) monitors the VCC_5V power input. When the voltage is lower than UVLO threshold voltage, the device is shut off and outputs are discharged. This is a non-latch protection.

7.3.8 Output Voltage Discharge

The VPP buck, VDDQ buck, VTT LDO, and VTTREF LDO block all have the discharge function by using internal MOSFETs, which are connected to the corresponding output terminals VPPSNS, VDDQSNS, VTT, and VTTREF. The discharge is slow due to the lower current capability of these MOSFETs.

Feature Description (continued)

7.3.9 Thermal Shutdown

The TPS65295 monitors the internal die temperature. If the temperature exceeds the threshold value (typically 150°C), the device is shut off and the output will be discharged. This is a non-latch protection. The device restarts switching when the temperature goes below the thermal shutdown recover threshold.

7.4 Device Functional Modes

7.4.1 Light Load Operation for VDDQ Buck and VPP Buck

When the load is light on the VDDQ or VPP output, the buck enters pulse skip mode after the inductor current crosses zero. This is the Eco-mode™ which improves the efficiency at light load with a lower switching frequency. Each switching cycle is followed by a period of energy saving sleep time. The sleep time ends when the VDDQSNS or VPPSNS voltage falls below the Eco-mode™ threshold voltage. As the output current decreases, the period time between switching pulses increases.

7.4.2 Output State Control

The TPS65295 has two enable input pins, SLP_S4 and VTT_CNTL, to provide simple control scheme of output state. All of VPP, VDDQ, VTTREF and VTT are turned on at S0 state (SLP_S4=VTT_CNTL=high). In S3 state (VTT_CNTL=low, SLP_S4=high), VPP, VDDQ, and VTTREF voltages are kept on while VTT is turned off and left at high impedance state (high-Z). The VTT output floats and does not sink or source current in this state. In S4/S5 states (SLP_S4=VTT_CNTL =low), all of the three outputs are turned off and discharged to GND. Each state code represents as follow: S0 = full ON, S3 = suspend to RAM (STR), S4 = suspend to disk (STD), S5 = soft OFF (see Table 1).

Table 1. VTT_CNTL and SLP_S4 Control for Output State

STATE	VTT_CNTL	SLP_S4	VPP	VDDQ	VTTREF	VTT
S0	HI	HI	ON	ON	ON	ON
S3	LO	HI	ON	ON	ON	OFF (High-Z)
S5/S4	LO	LO	OFF (discharge)	OFF (discharge)	OFF (discharge)	OFF (discharge)

7.4.3 Output Sequence Control

There are specific sequencing requirements for the DDR4 VDDQ and VPP rails. The TPS65295 follows the DDR4 power rail sequence requirements as shown in Figure 29 and Figure 30. VPP is greater than VDDQ at all times during ramp up, operating, and ramp down. The VTT output ramp and stable within 35 μs after VTT_CNTL asserted.

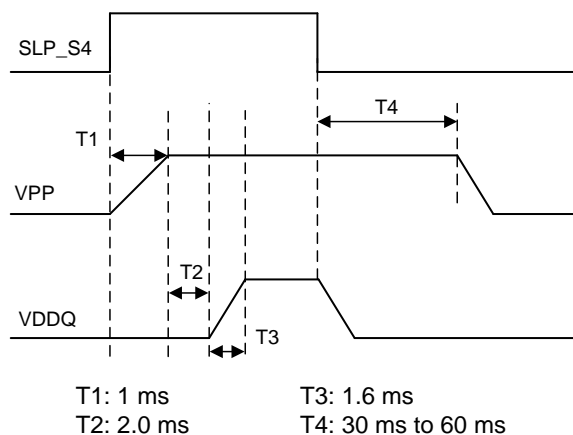

Figure 29. Power Sequence, VPP and VDDQ vs SLP_S4

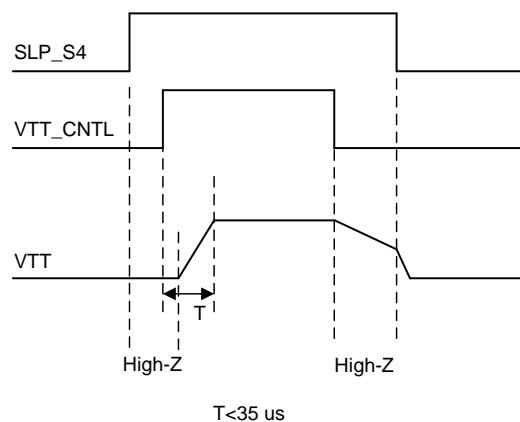

Figure 30. Power Sequence, VTT vs VTT_CNTL

8 Application and Implementation

NOTE

Information in the following applications sections is not part of the TI component specification, and TI does not warrant its accuracy or completeness. TI's customers are responsible for determining suitability of components for their purposes. Customers should validate and test their design implementation to confirm system functionality.

8.1 Application Information

The schematic of [Figure 31](#) shows a typical application for TPS65295. For VDDQ buck, the PVIN supports 4.5-V to 18-V input range with 1.2-V VDDQ output, the continuous current capability is 8 A. Usually the PVIN_VPP and VCC_5V can share one 5-V power input and supports 2.5-V VPP output with 1-A continuous current capability, of course the PVIN_VPP can be lowered down to a 3.3-V power supply. The VLDOIN power input usually is connected to VDDQ output, while also it can be connected to external 1.2-V power supply input. The VTTREF output voltage will follow the 1/2 VDDQSNS voltage, and VTT output voltage will follow the VTTREF output voltage, this is required by DDR4 power supply standard.

8.2 Typical Application

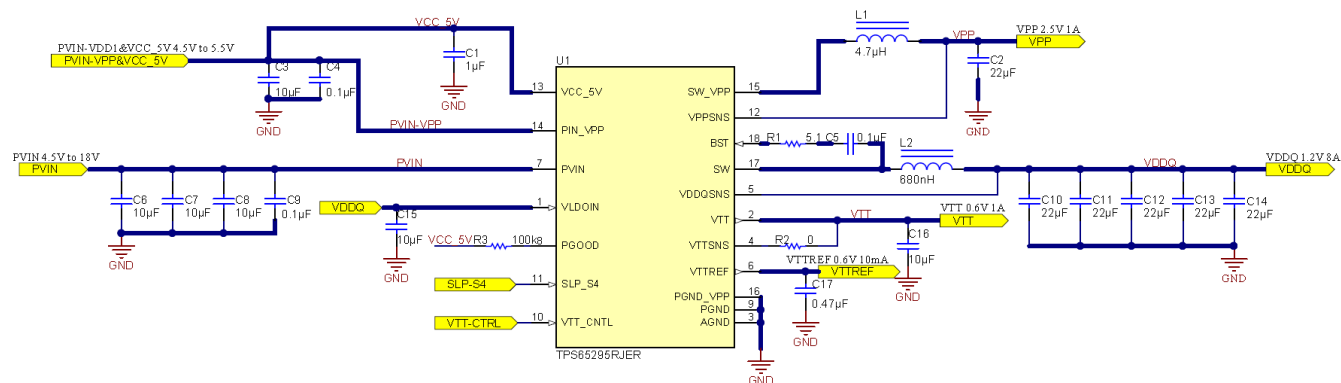

Figure 31. Application Schematic

8.2.1 Design Requirements

Table 2 lists the design parameters for this example.

Table 2. Design Parameters

PARAMETER	CONDITIONS	MIN	TYP	MAX	UNIT
VDDQ OUTPUT					
V _{OUT}	Output voltage		1.2		V
I _{OUT}	Output current		8		A
ΔV _{OUT}	Transient response		±60		mV
V _{IN}	Input voltage	4.5	12	18	V
V _{OUT(ripple)}	Output voltage ripple		40		mV _(P-P)
F _{SW}	Switching frequency		600		kHz
VPP OUTPUT					
V _{OUT}	Output voltage		2.5		V
I _{OUT}	Output current		1		A
ΔV _{OUT}	Transient response		±125		mV
V _{IN}	Input voltage	3	5	5.5	V

Typical Application (continued)

Table 2. Design Parameters (continued)

PARAMETER		CONDITIONS	MIN	TYP	MAX	UNIT
V _{OUT(ripple)}	Output voltage ripple			40		mV _(P-P)
F _{SW}	Switching frequency			580		kHz
OTHERS						
V _{VCC_5V}	Start VCC_5V input voltage	VCC_5V Input voltage rising		Internal UVLO		V
	Stop VCC_5V input voltage	VCC_5V Input voltage falling		Internal UVLO		V
	Light load operating mode			ECO		
T _A	Ambient temperature			25		°C

8.2.2 Detailed Design Procedure

8.2.2.1 External Component Selection

8.2.2.1.1 Inductor Selection

The inductor ripple current is filtered by the output capacitor. A higher inductor ripple current means the output capacitor should have a ripple current rating higher than the inductor ripple current. See [Table 3](#) for recommended inductor values.

The RMS and peak currents through the inductor can be calculated using [Equation 3](#) and [Equation 4](#). It is important that the inductor is rated to handle these currents.

$$I_{L(\text{rms})} = \sqrt{\left(I_{\text{OUT}}^2 + \frac{1}{12} \times \left(\frac{V_{\text{OUT}} \times (V_{\text{IN}(\text{max})} - V_{\text{OUT}})}{V_{\text{IN}(\text{max})} \times L_{\text{OUT}} \times F_{\text{SW}}} \right)^2 \right)} \quad (3)$$

$$I_{L(\text{peak})} = I_{\text{OUT}} + \frac{I_{\text{OUT}(\text{ripple})}}{2} \quad (4)$$

During transient and short-circuit conditions, the inductor current can increase up to the current limit of the device so it is safe to choose an inductor with a saturation current higher than the peak current under current limit condition.

8.2.2.1.2 Output Capacitor Selection

After selecting the inductor the output capacitor needs to be optimized. In DCAP3, the regulator reacts within one cycle to the change in the duty cycle so the good transient performance can be achieved without needing large amounts of output capacitance. The recommended output capacitance range is given in [Table 3](#).

Ceramic capacitors have very low ESR, otherwise the maximum ESR of the capacitor should be less than $V_{\text{OUT}(\text{ripple})}/I_{\text{OUT}(\text{ripple})}$.

Table 3. Recommended Component Values

V _{OUT} (V)	F _{SW} (kHz)	L _{OUT} (μH)	C _{OUT(min)} (μF)	C _{OUT(max)} (μF)
1.2	600	0.68	88	132
	600	0.56	88	132
	600	0.47	88	132
2.5	580	6.8	20	66
	580	4.7	20	66
	580	3.3	20	66

For VTT output, high quality X5R or X7R 10-μF capacitor is recommended and a 0.47 μF is recommended for VTTREF output.

8.2.2.1.3 Input Capacitor Selection

The TPS65295 requires input decoupling capacitors on both power supply input PVIN and PVIN_VPP, and the bulk capacitors are needed depending on the application. The minimum input capacitance required is given in Equation 5.

$$C_{IN(min)} = \frac{I_{OUT} \times V_{OUT}}{V_{INripple} \times V_{IN} \times F_{SW}} \tag{5}$$

TI recommends using a high-quality X5R or X7R input decoupling capacitors of 30 μF on the VDDQ buck input voltage pin PVIN, and 10 μF on the VPP buck input voltage pin PVIN_VPP. The voltage rating on the input capacitor must be greater than the maximum input voltage. The capacitor must also have a ripple current rating greater than the maximum input current ripple of the application. The input ripple current is calculated by Equation 6:

$$I_{CIN(rms)} = I_{OUT} \times \sqrt{\frac{V_{OUT}}{V_{IN(min)}} \times \frac{(V_{IN(min)} - V_{OUT})}{V_{IN(min)}}} \tag{6}$$

An additional 0.1-μF capacitor from PVIN to ground and from PVIN_VPP to ground is optional to provide additional high frequency filtering. One ceramic capacitor of 10 μF is recommended for the decoupling capacitor on VLDOIN pin for providing stable power on VTT LDO block. A 1-μF ceramic capacitor is needed for the decoupling capacitor on VCC_5V input.

8.2.2.1.4 Bootstrap Capacitor and Resistor Selection

A 0.1-μF ceramic capacitor serialized with a 5.1-Ω resistor is recommended between the BST and SW pin for proper operation. TI recommends using a ceramic capacitor.

8.2.3 Application Curves

Figure 32 through Figure 60 apply to the circuit of Figure 31. $V_{IN} = 12\text{ V}$. $T_A = 25^\circ\text{C}$ unless otherwise specified.

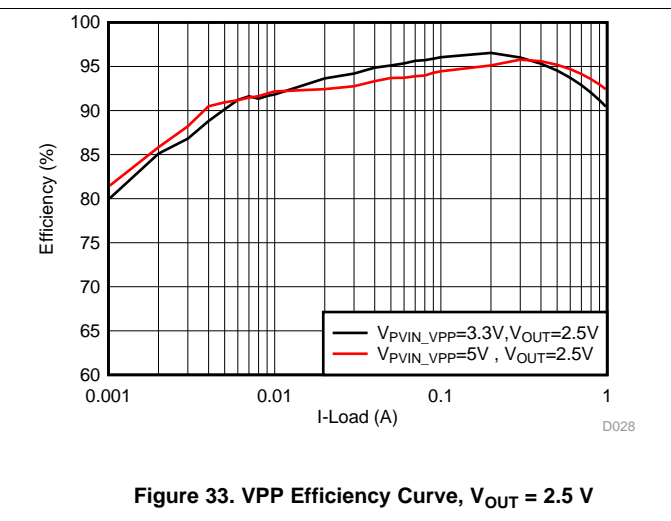
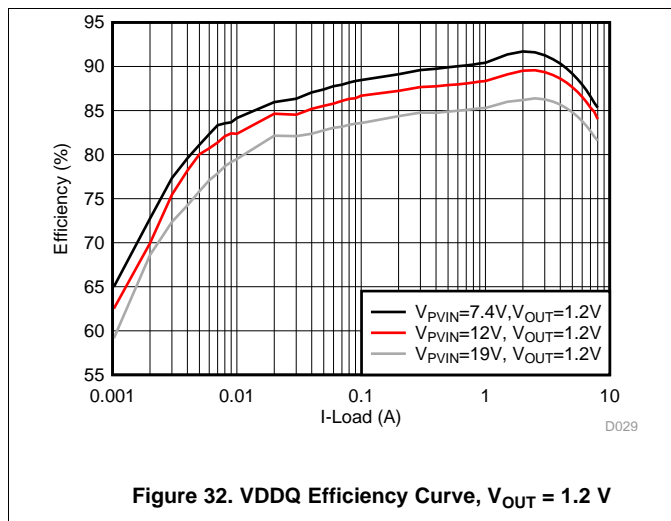

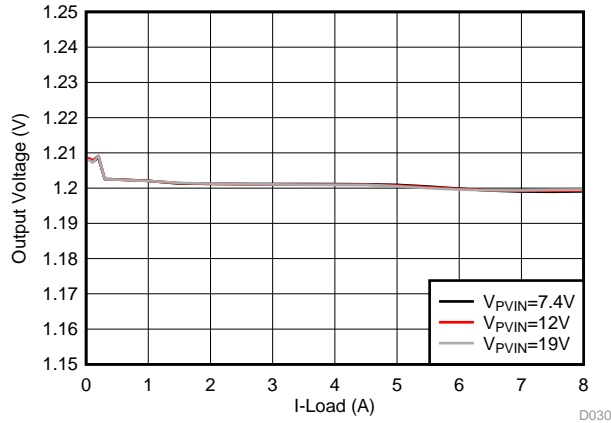

Figure 34. VDDQ Load Regulation, $V_{OUT} = 1.2\text{ V}$

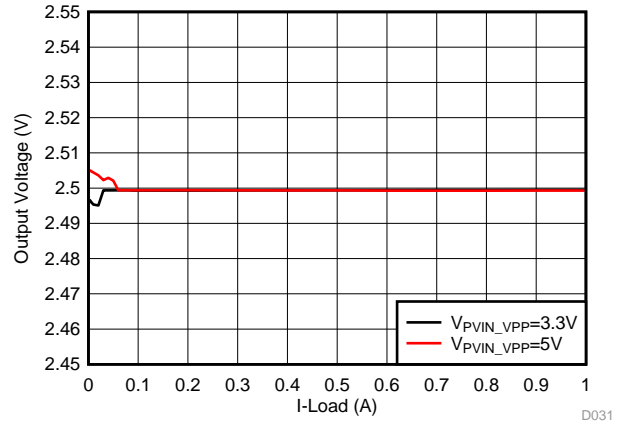

Figure 35. VPP Load Regulation, $V_{OUT} = 2.5\text{ V}$

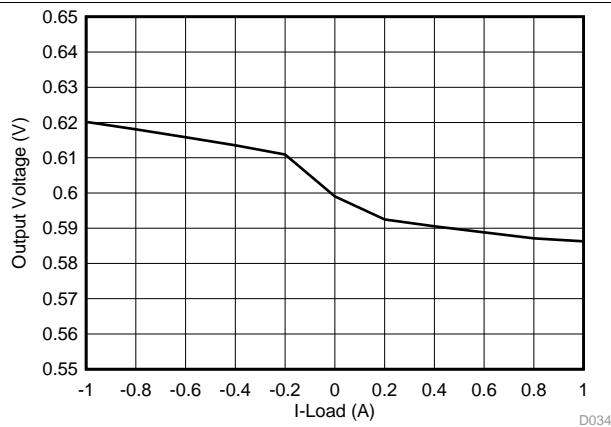

Figure 36. VTT Load Regulation, $V_{OUT} = 0.6\text{ V}$

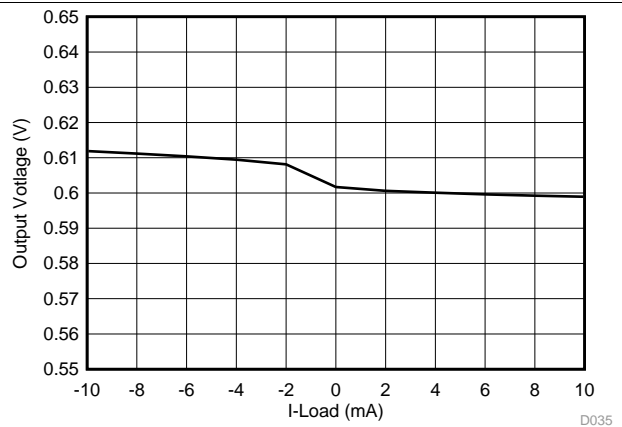

Figure 37. VTTREF Load Regulation, $V_{OUT} = 0.6\text{ V}$

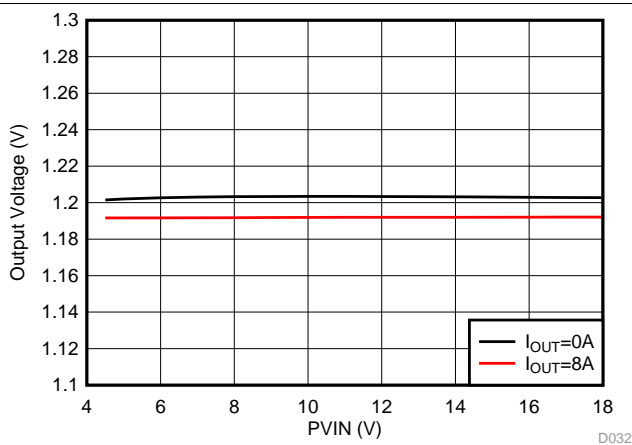

Figure 38. VDDQ Line Regulation, $V_{OUT} = 1.2\text{ V}$

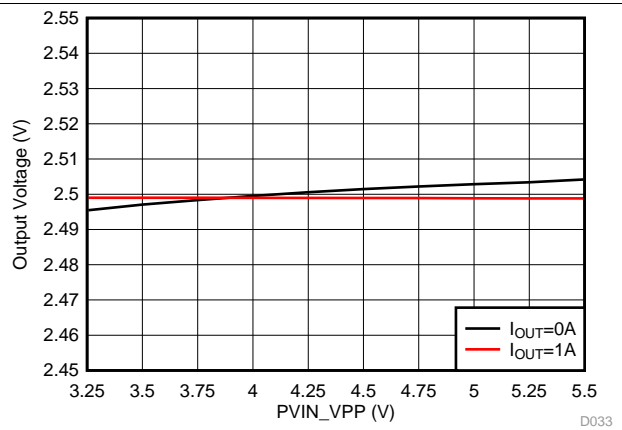

Figure 39. VPP Line Regulation, $V_{OUT} = 2.5\text{ V}$

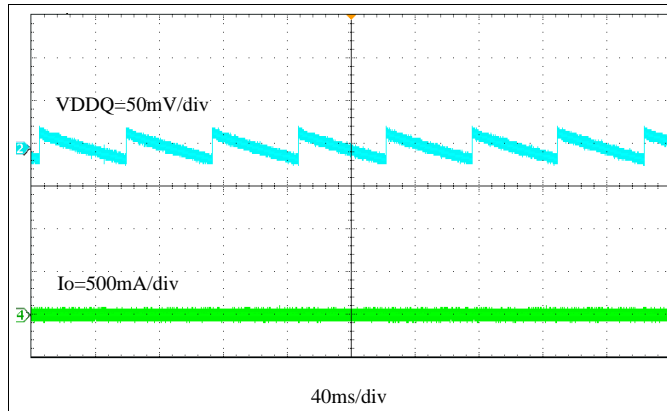

Figure 40. VDDQ Output Voltage Ripple, $I_{OUT} = 0\text{ A}$

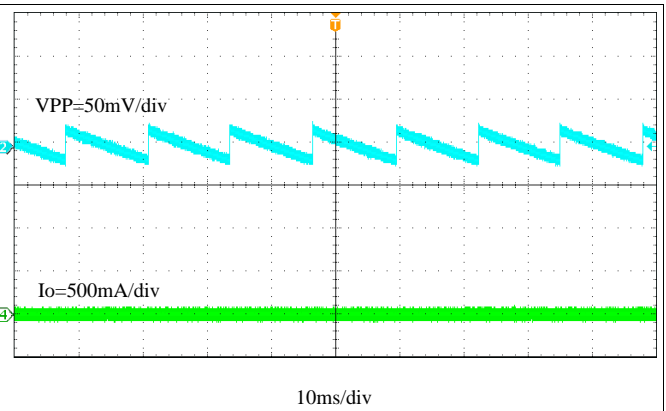

Figure 41. VPP Output Voltage Ripple, $I_{OUT} = 0\text{ A}$

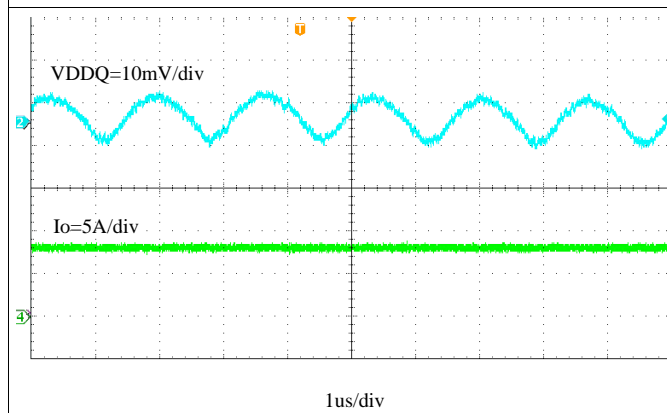

Figure 42. VDDQ Output Voltage Ripple, $I_{OUT} = 8\text{ A}$

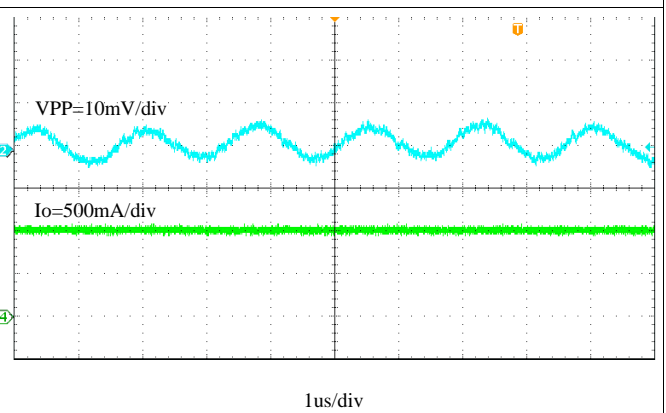

Figure 43. VPP Output Voltage Ripple, $I_{OUT} = 1\text{ A}$

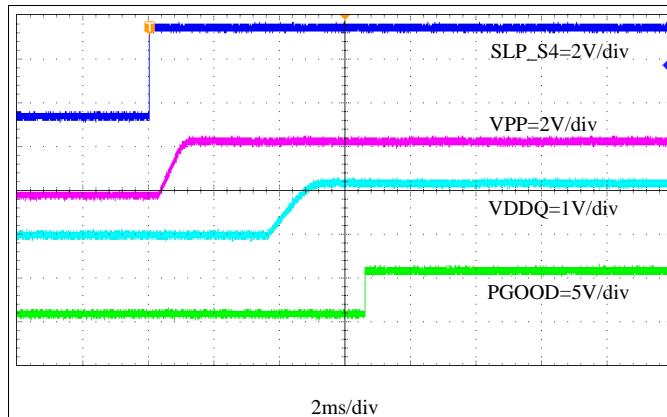

Figure 44. Start-Up Through SLP_S4, $I_{VPP_OUT} = 0\text{ A}$, $I_{VDDQ_OUT} = 0\text{ A}$

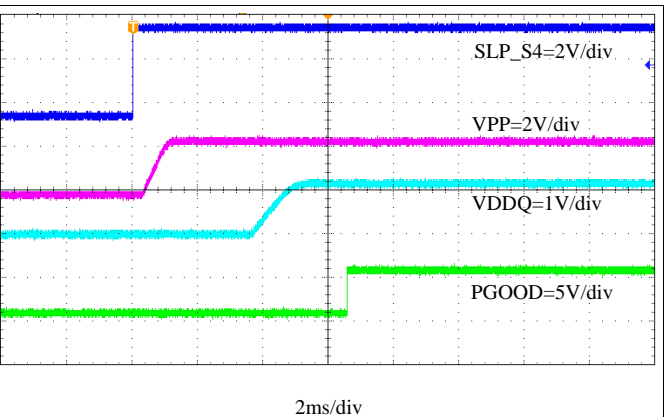
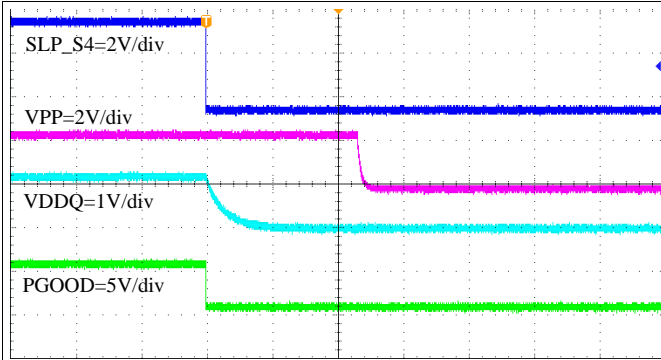
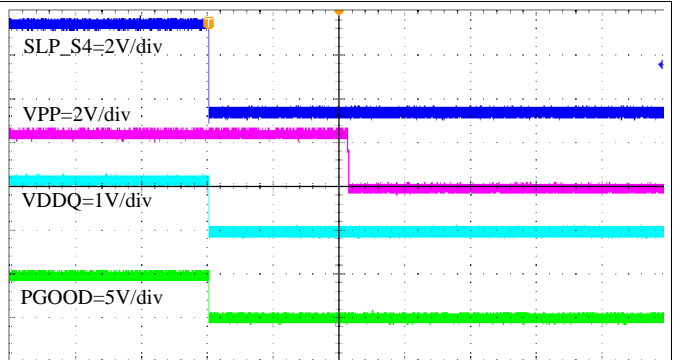

Figure 45. Start-Up Through SLP_S4, $I_{VPP_OUT} = 1\text{ A}$, $I_{VDDQ_OUT} = 8\text{ A}$



20ms/div

Figure 46. Shutdown Through SLP_S4, $I_{VPPOUT} = 0\text{ A}$, $I_{VDDQOUT} = 0\text{ A}$



20ms/div

Figure 47. Shutdown Through SLP_S4, $I_{VPPOUT} = 1\text{ A}$, $I_{VDDQOUT} = 8\text{ A}$

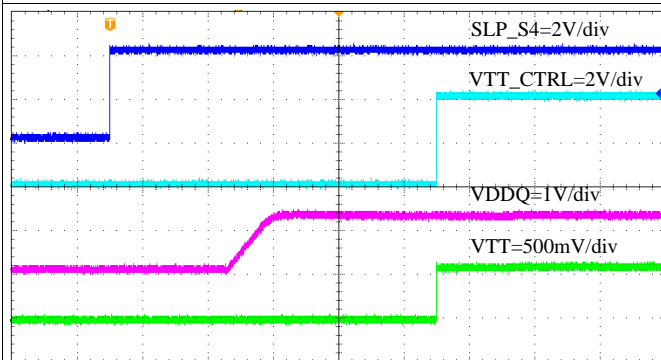

$I_{VDDQOUT} = 0\text{ A}$ 2ms/div
 $I_{VTT} = 0\text{ A}$ $I_{VTTREF} = 0\text{ A}$

Figure 48. VTT Start-Up Through VTT_CTRL

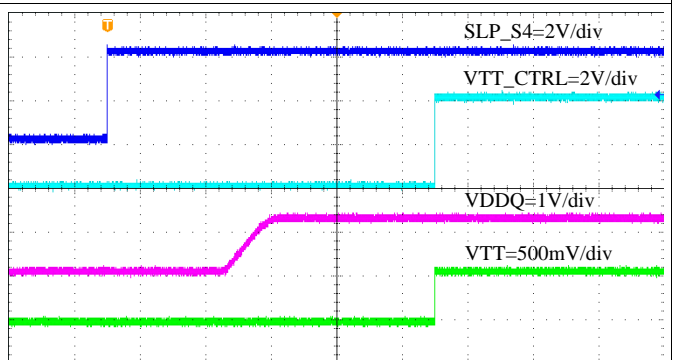

$I_{VDDQOUT} = 8\text{ A}$ 2ms/div
 $I_{VTT} = 1\text{ A}$ $I_{VTTREF} = 10\text{ mA}$

Figure 49. VTT Start-Up Through VTT_CTRL

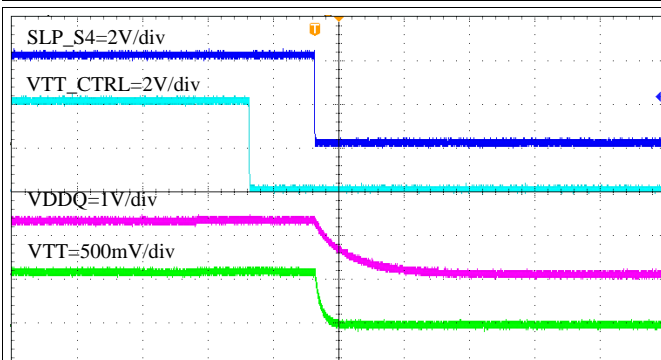

$I_{VDDQOUT} = 0\text{ A}$ 10ms/div
 $I_{VTT} = 0\text{ A}$ $I_{VTTREF} = 0\text{ A}$

Figure 50. VTT Shutdown Through VTT_CTRL

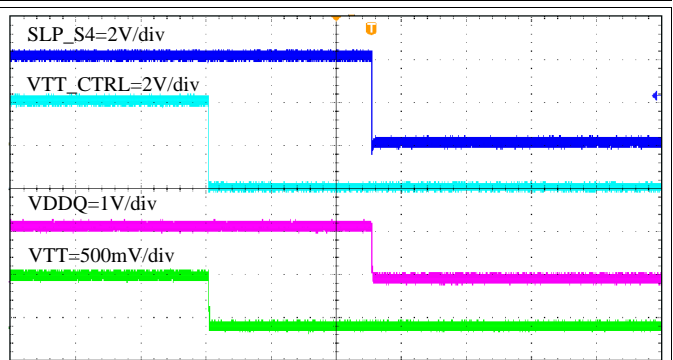

$I_{VDDQOUT} = 8\text{ A}$ 4ms/div
 $I_{VTT} = 1\text{ A}$ $I_{VTTREF} = 10\text{ mA}$

Figure 51. VTT Shutdown Through VTT_CTRL

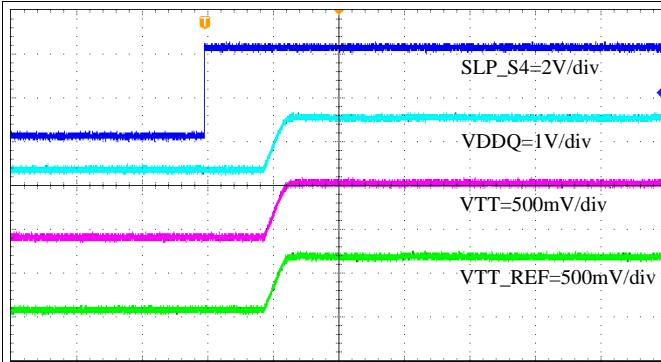

$I_{VDDQOUT} = 0\text{ A}$ 4ms/div $I_{VTT} = 0\text{ A}$ $I_{VTTREF} = 0\text{ A}$

Figure 52. VTT Start-Up Through SLP_S4

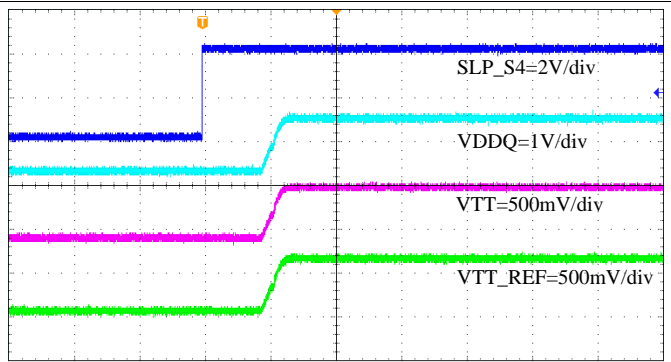

$I_{VDDQOUT} = 8\text{ A}$ 4ms/div $I_{VTT} = 1\text{ A}$ $I_{VTTREF} = 10\text{ mA}$

Figure 53. VTT Start-Up Through SLP_S4

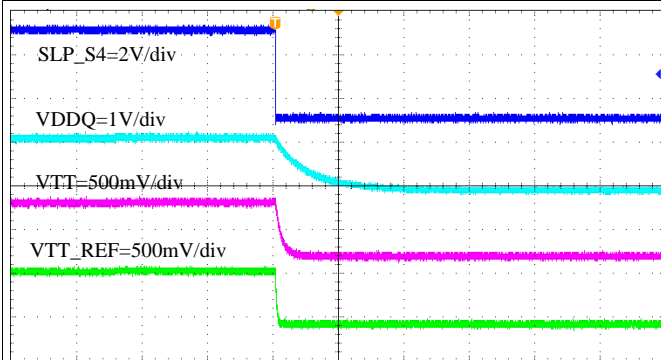

$I_{VDDQOUT} = 0\text{ A}$ 10ms/div $I_{VTT} = 0\text{ A}$ $I_{VTTREF} = 0\text{ A}$

Figure 54. VTT Shutdown Through SLP_S4

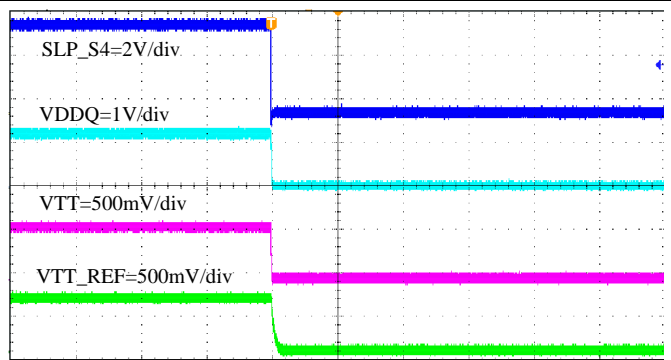

$I_{VDDQOUT} = 8\text{ A}$ 4ms/div $I_{VTT} = 1\text{ A}$ $I_{VTTREF} = 10\text{ mA}$

Figure 55. VTT Shutdown Through SLP_S4

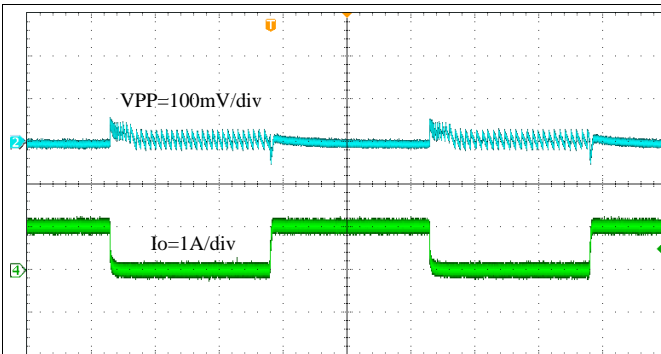

Slew Rate=2.5A/us 400us/div

Figure 56. VPP Transient Response, 0 A to 1 A

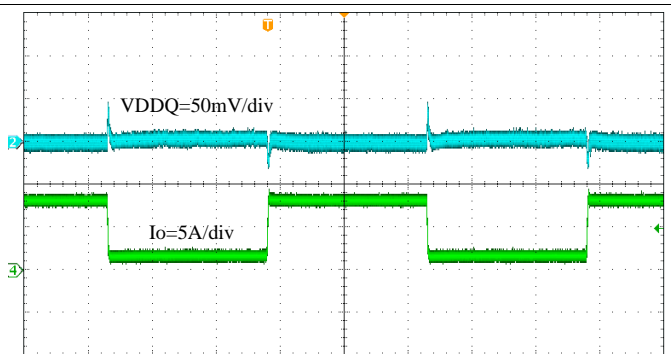

Slew Rate=2.5A/us 400us/div

Figure 57. VDDQ Transient Response, 1.6 A to 8 A

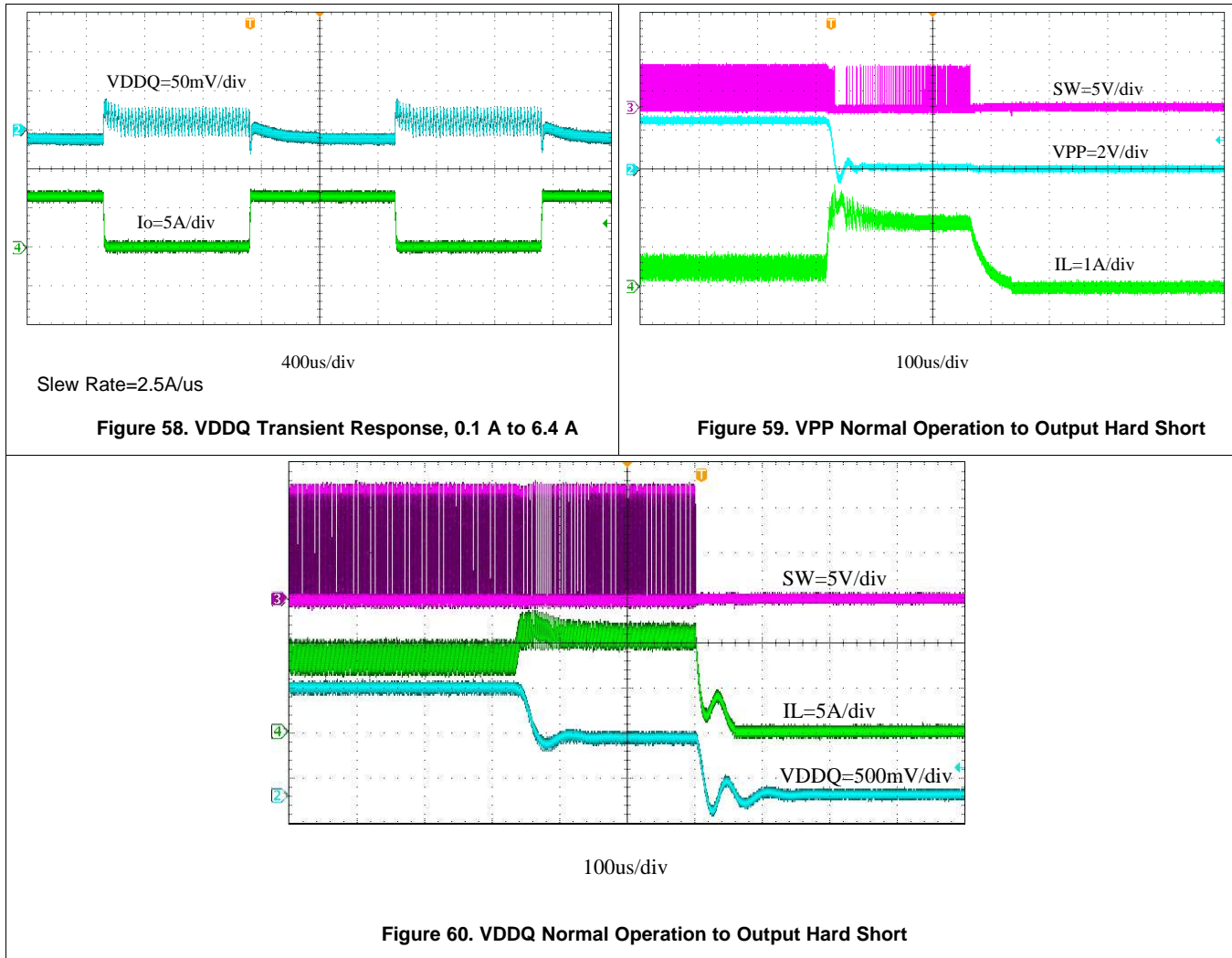

9 Power Supply Recommendations

TPS65295 is designed for DDR4 complete power solution. PVIN is the power input for VDDQ buck, PVIN_VPP is the power input for VPP buck, VLDOIN input is for VTT LDO power supply, VCC_5V is power supply for internal control logic. Below lists the power on sequence scenarios.

- SLP_S4 is high before PVIN or PVIN_VPP has the power input, VCC_5V power supply must be provided after or same time with PVIN or PVIN_VPP, otherwise the output will be latched, this latch can be recovered by toggling the SLP_S4 pin or re-power the VCC_5V
- SLP_S4 is low before PVIN and PVIN_VPP has the power input, then there is no power supply input sequence requirement for VCC_5V, PVIN and PVIN_VPP.

10 Layout

10.1 Layout Guidelines

- Recommend a four-layer PCB for good thermal performance and with maximum ground plane. 3-inch x 3-inch, four-layer PCB with 2-oz. copper used as example.
- Place the decoupling capacitors right across PVIN, PVIN_VPP, and VLDOIN as close as possible.
- Place output inductors and capacitors with IC at the same layer, SW routing should be as short as possible to minimize EMI, and should be a wide plane to carry big current, enough vias should be added to the PGND connection of output capacitor and also as close to the output pin as possible. Reserve some space between VDDQ choke and VPP choke, just minimize radiation crosstalk.
- Place BST resistor and capacitor with IC at the same layer, close to BST and SW plane, >15 mil width trace is recommended to reduce line parasitic inductance.
- VPPSNS/VDDQSNS/VTTSENS could be 10 mil and must be routed away from the switching node, BST node or other high efficiency signal.
- PVIN and PVIN_VPP trace must be wide to reduce the trace impedance and provide enough current capability.
- Output capacitors for VTT and VTTREF should be put as close as output pin.

10.2 Layout Example

Figure 61 shows the recommended top-side layout. Component reference designators are the same as the circuit shown in Figure 31.

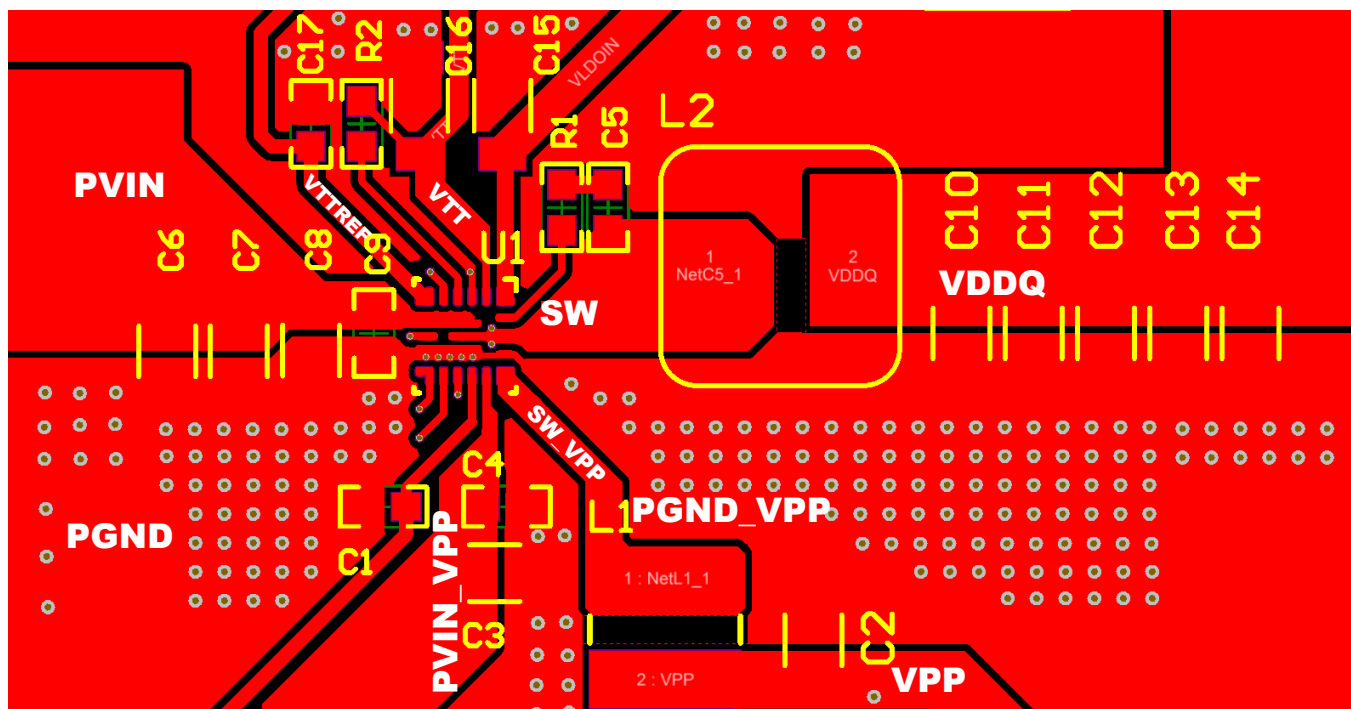

Figure 61. Top-Side Layout

11 Device and Documentation Support

11.1 Device Support

11.1.1 Third-Party Products Disclaimer

TI'S PUBLICATION OF INFORMATION REGARDING THIRD-PARTY PRODUCTS OR SERVICES DOES NOT CONSTITUTE AN ENDORSEMENT REGARDING THE SUITABILITY OF SUCH PRODUCTS OR SERVICES OR A WARRANTY, REPRESENTATION OR ENDORSEMENT OF SUCH PRODUCTS OR SERVICES, EITHER ALONE OR IN COMBINATION WITH ANY TI PRODUCT OR SERVICE.

11.2 Receiving Notification of Documentation Updates

To receive notification of documentation updates, navigate to the device product folder on ti.com. In the upper right corner, click on *Alert me* to register and receive a weekly digest of any product information that has changed. For change details, review the revision history included in any revised document.

11.3 Community Resources

The following links connect to TI community resources. Linked contents are provided "AS IS" by the respective contributors. They do not constitute TI specifications and do not necessarily reflect TI's views; see TI's [Terms of Use](#).

TI E2E™ Online Community *TI's Engineer-to-Engineer (E2E) Community*. Created to foster collaboration among engineers. At e2e.ti.com, you can ask questions, share knowledge, explore ideas and help solve problems with fellow engineers.

Design Support *TI's Design Support* Quickly find helpful E2E forums along with design support tools and contact information for technical support.

11.4 Trademarks

D-CAP3, Eco-mode, HotRod, DCAP3, E2E are trademarks of Texas Instruments. All other trademarks are the property of their respective owners.

11.5 Electrostatic Discharge Caution



These devices have limited built-in ESD protection. The leads should be shorted together or the device placed in conductive foam during storage or handling to prevent electrostatic damage to the MOS gates.

11.6 Glossary

[SLYZ022](#) — *TI Glossary*.

This glossary lists and explains terms, acronyms, and definitions.

12 Mechanical, Packaging, and Orderable Information

The following pages include mechanical, packaging, and orderable information. This information is the most current data available for the designated devices. This data is subject to change without notice and revision of this document. For browser-based versions of this data sheet, refer to the left-hand navigation.

12.1 Package Option Addendum

12.1.1 Packaging Information

Orderable Device	Status ⁽¹⁾	Package Type	Package Drawing	Pins	Package Qty	Eco Plan ⁽²⁾	Lead/Ball Finish ⁽³⁾	MSL Peak Temp ⁽⁴⁾	Op Temp (°C)	Device Marking ⁽⁵⁾⁽⁶⁾
TPS65295RJER	PRE_PROD	VQFN-HR	RJE	18	3000	Green (RoHS & no Sb/Br)	CU NIPDAU	Level-2-260C-1 YEAR	-40 to 125	65295
TPS65295RJET	PRE_PROD	VQFN-HR	RJE	18	250	Green (RoHS & no Sb/Br)	CU NIPDAU	Level-2-260C-1 YEAR	-40 to 125	65295

- (1) The marketing status values are defined as follows:
ACTIVE: Product device recommended for new designs.
LIFEBUY: TI has announced that the device will be discontinued, and a lifetime-buy period is in effect.
NRND: Not recommended for new designs. Device is in production to support existing customers, but TI does not recommend using this part in a new design.
PRE_PROD Unannounced device, not in production, not available for mass market, nor on the web, samples not available.
PREVIEW: Device has been announced but is not in production. Samples may or may not be available.
OBSOLETE: TI has discontinued the production of the device.
- (2) Eco Plan - The planned eco-friendly classification: Pb-Free (RoHS), Pb-Free (RoHS Exempt), or Green (RoHS & no Sb/Br) - please check <http://www.ti.com/productcontent> for the latest availability information and additional product content details.
TBD: The Pb-Free/Green conversion plan has not been defined.
Pb-Free (RoHS): TI's terms "Lead-Free" or "Pb-Free" mean semiconductor products that are compatible with the current RoHS requirements for all 6 substances, including the requirement that lead not exceed 0.1% by weight in homogeneous materials. Where designed to be soldered at high temperatures, TI Pb-Free products are suitable for use in specified lead-free processes.
Pb-Free (RoHS Exempt): This component has a RoHS exemption for either 1) lead-based flip-chip solder bumps used between the die and package, or 2) lead-based die adhesive used between the die and leadframe. The component is otherwise considered Pb-Free (RoHS compatible) as defined above.
Green (RoHS & no Sb/Br): TI defines "Green" to mean Pb-Free (RoHS compatible), and free of Bromine (Br) and Antimony (Sb) based flame retardants (Br or Sb do not exceed 0.1% by weight in homogeneous material)
- (3) Lead/Ball Finish - Orderable Devices may have multiple material finish options. Finish options are separated by a vertical ruled line. Lead/Ball Finish values may wrap to two lines if the finish value exceeds the maximum column width.
- (4) MSL, Peak Temp. -- The Moisture Sensitivity Level rating according to the JEDEC industry standard classifications, and peak solder temperature.
- (5) There may be additional marking, which relates to the logo, the lot trace code information, or the environmental category on the device
- (6) Multiple Device markings will be inside parentheses. Only one Device Marking contained in parentheses and separated by a "-" will appear on a device. If a line is indented then it is a continuation of the previous line and the two combined represent the entire Device Marking for that device.

Important Information and Disclaimer: The information provided on this page represents TI's knowledge and belief as of the date that it is provided. TI bases its knowledge and belief on information provided by third parties, and makes no representation or warranty as to the accuracy of such information. Efforts are underway to better integrate information from third parties. TI has taken and continues to take reasonable steps to provide representative and accurate information but may not have conducted destructive testing or chemical analysis on incoming materials and chemicals. TI and TI suppliers consider certain information to be proprietary, and thus CAS numbers and other limited information may not be available for release.

In no event shall TI's liability arising out of such information exceed the total purchase price of the TI part(s) at issue in this document sold by TI to Customer on an annual basis.

12.1.2 Tape and Reel Information

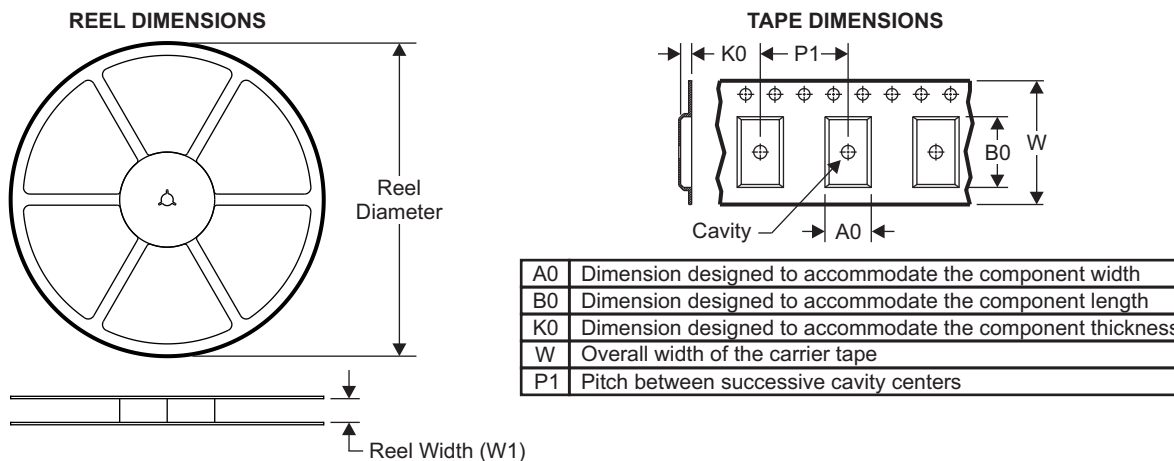

QUADRANT ASSIGNMENTS FOR PIN 1 ORIENTATION IN TAPE

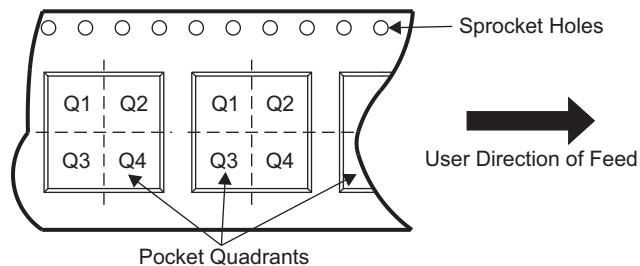

Device	Package Type	Package Drawing	Pins	SPQ	Reel Diameter (mm)	Reel Width W1 (mm)	A0 (mm)	B0 (mm)	K0 (mm)	P1 (mm)	W (mm)	Pin1 Quadrant
TPS65295RJER	VQFN-HR	RJE	18	3000	330	12.4	3.3	3.3	1.1	8	12	Q2
TPS65295RJET	VQFN-HR	RJE	18	250	180	12.4	3.3	3.3	1.1	8	12	Q2

TPS65295

SLUSDK5 – FEBRUARY 2019

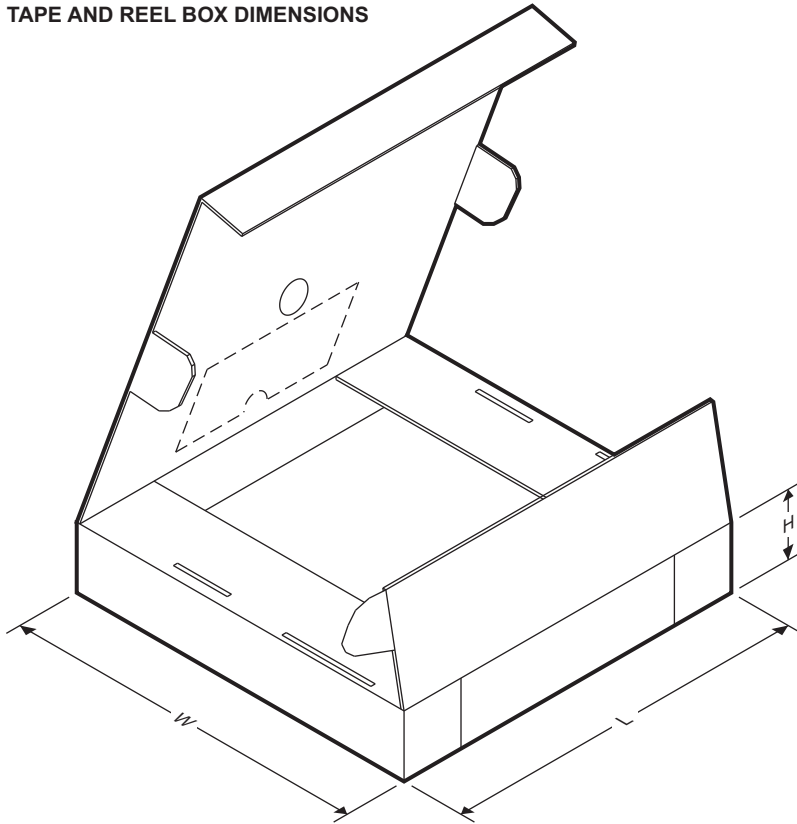
www.ti.com
TAPE AND REEL BOX DIMENSIONS

Device	Package Type	Package Drawing	Pins	SPQ	Length (mm)	Width (mm)	Height (mm)
TPS65295RJER	VQFN-HR	RJE	18	3000	367	367	35
TPS65295RJET	VQFN-HR	RJE	18	250	210	185	35

PACKAGE OUTLINE
VQFN-HR - 1 mm max height

RJE0018B

PLASTIC QUAD FLATPACK- NO LEAD

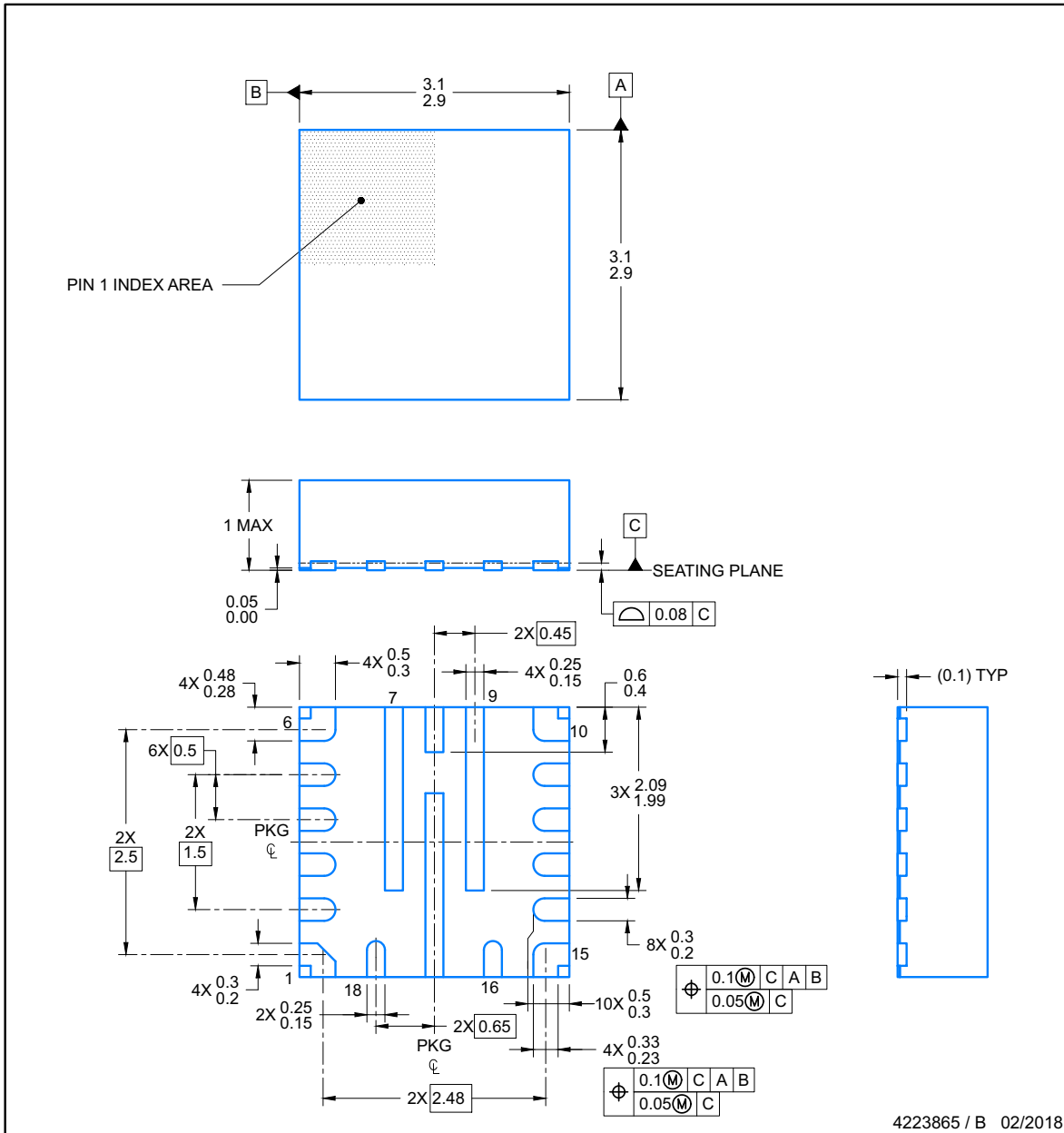

NOTES:

1. All linear dimensions are in millimeters. Any dimensions in parenthesis are for reference only. Dimensioning and tolerancing per ASME Y14.5M.
2. This drawing is subject to change without notice.

EXAMPLE BOARD LAYOUT

VQFN-HR - 1 mm max height

RJE0018B

PLASTIC QUAD FLATPACK- NO LEAD

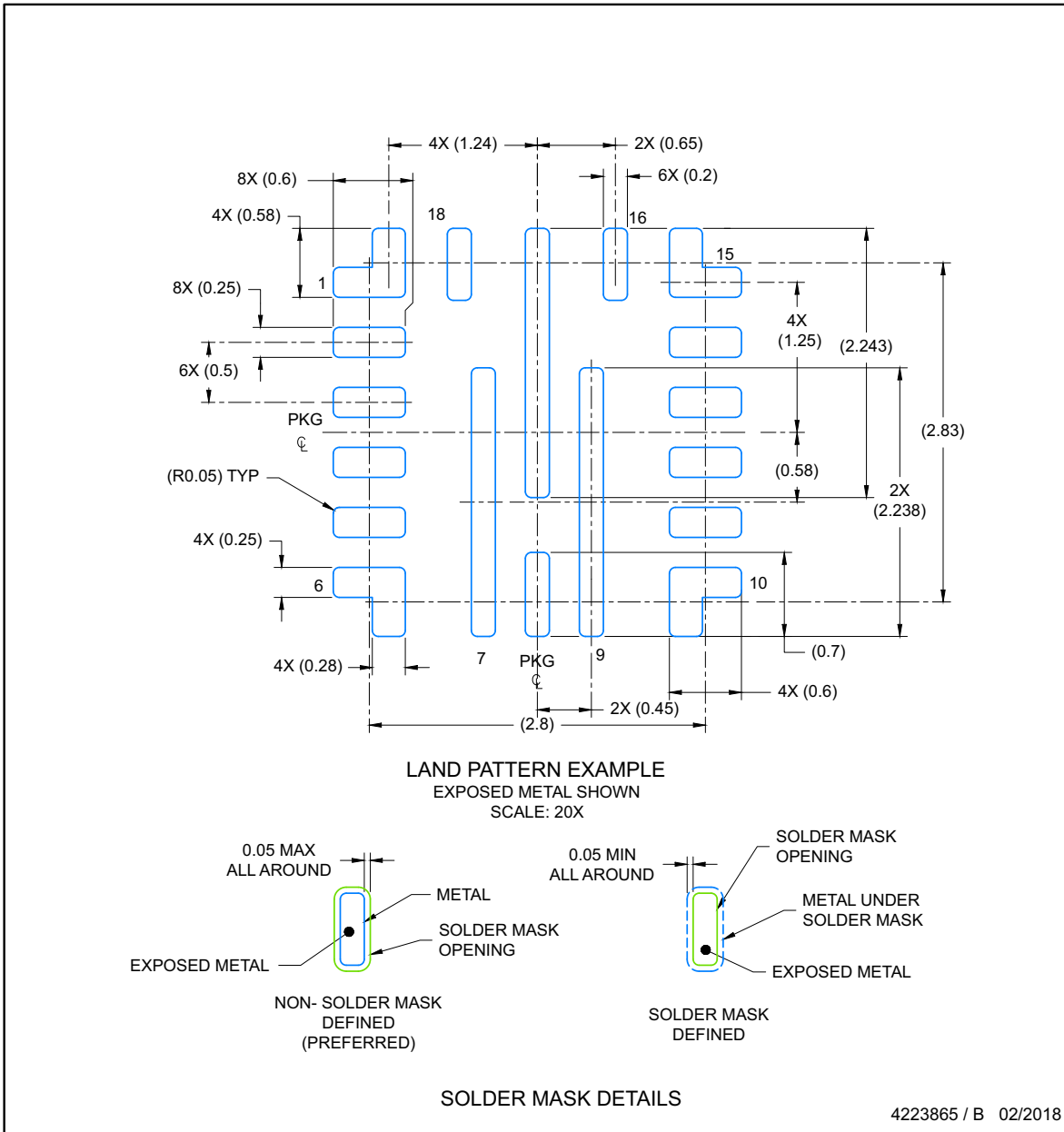

NOTES: (continued)

- For more information, see Texas Instruments literature number SLUA271 (www.ti.com/lit/slua271).
- Solder mask tolerances between and around signal pads can vary based on board fabrication site.

EXAMPLE STENCIL DESIGN

RJE0018B

VQFN-HR - 1 mm max height

PLASTIC QUAD FLATPACK- NO LEAD

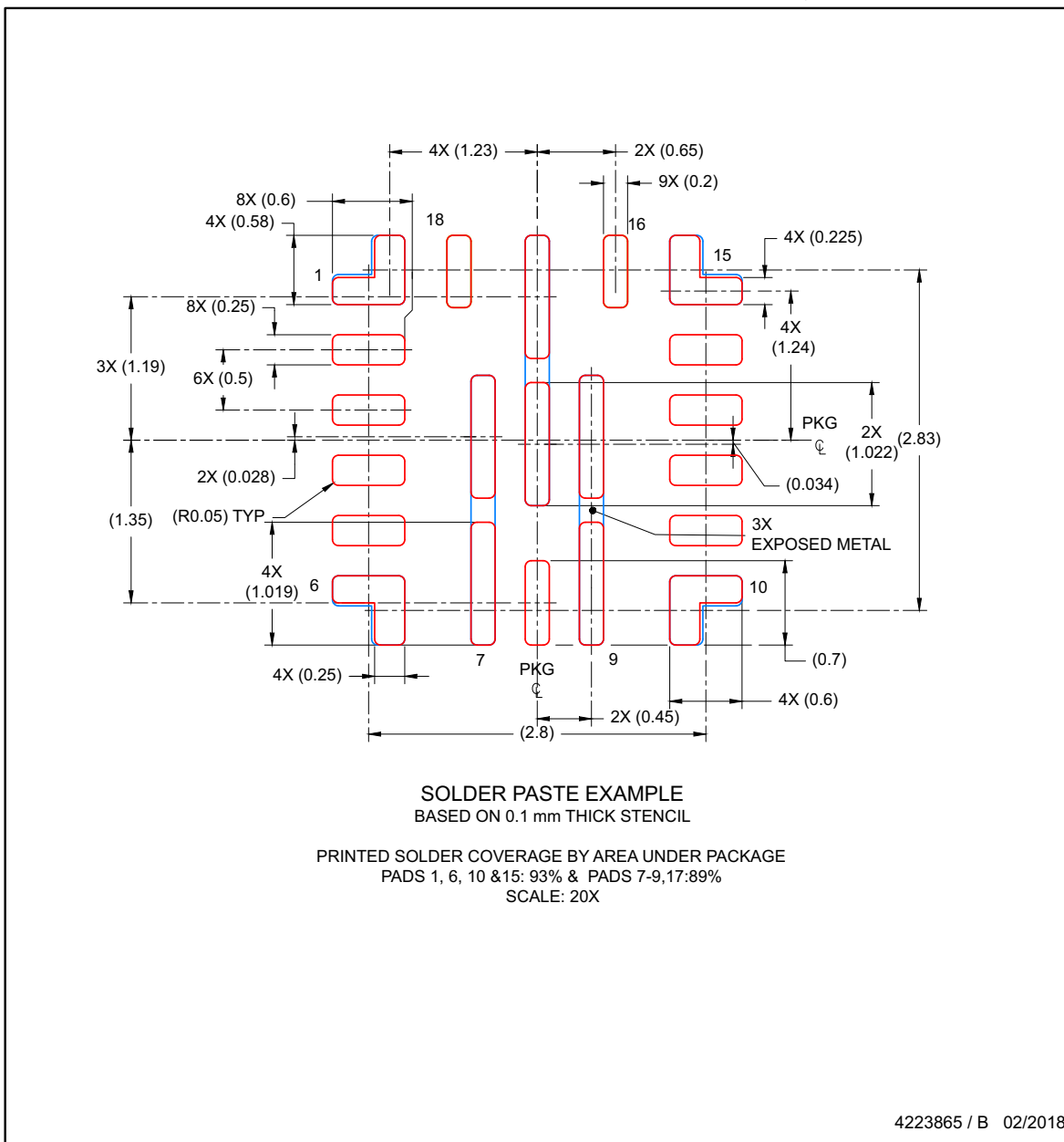

NOTES: (continued)

5. Laser cutting apertures with trapezoidal walls and rounded corners may offer better paste release. IPC-7525 may have alternate design recommendations..

PACKAGING INFORMATION

Orderable Device	Status (1)	Package Type	Package Drawing	Pins	Package Qty	Eco Plan (2)	Lead/Ball Finish (6)	MSL Peak Temp (3)	Op Temp (°C)	Device Marking (4/5)	Samples
TPS65295RJER	ACTIVE	VQFN-HR	RJE	18	3000	Green (RoHS & no Sb/Br)	CU NIPDAU	Level-2-260C-1 YEAR	-40 to 125	65295	Samples
TPS65295RJET	ACTIVE	VQFN-HR	RJE	18	250	Green (RoHS & no Sb/Br)	CU NIPDAU	Level-2-260C-1 YEAR	-40 to 125	65295	Samples

(1) The marketing status values are defined as follows:

ACTIVE: Product device recommended for new designs.

LIFEBUY: TI has announced that the device will be discontinued, and a lifetime-buy period is in effect.

NRND: Not recommended for new designs. Device is in production to support existing customers, but TI does not recommend using this part in a new design.

PREVIEW: Device has been announced but is not in production. Samples may or may not be available.

OBsolete: TI has discontinued the production of the device.

(2) **RoHS:** TI defines "RoHS" to mean semiconductor products that are compliant with the current EU RoHS requirements for all 10 RoHS substances, including the requirement that RoHS substance do not exceed 0.1% by weight in homogeneous materials. Where designed to be soldered at high temperatures, "RoHS" products are suitable for use in specified lead-free processes. TI may reference these types of products as "Pb-Free".

RoHS Exempt: TI defines "RoHS Exempt" to mean products that contain lead but are compliant with EU RoHS pursuant to a specific EU RoHS exemption.

Green: TI defines "Green" to mean the content of Chlorine (Cl) and Bromine (Br) based flame retardants meet JS709B low halogen requirements of <=1000ppm threshold. Antimony trioxide based flame retardants must also meet the <=1000ppm threshold requirement.

(3) MSL, Peak Temp. - The Moisture Sensitivity Level rating according to the JEDEC industry standard classifications, and peak solder temperature.

(4) There may be additional marking, which relates to the logo, the lot trace code information, or the environmental category on the device.

(5) Multiple Device Markings will be inside parentheses. Only one Device Marking contained in parentheses and separated by a "~" will appear on a device. If a line is indented then it is a continuation of the previous line and the two combined represent the entire Device Marking for that device.

(6) Lead/Ball Finish - Orderable Devices may have multiple material finish options. Finish options are separated by a vertical ruled line. Lead/Ball Finish values may wrap to two lines if the finish value exceeds the maximum column width.

Important Information and Disclaimer:The information provided on this page represents TI's knowledge and belief as of the date that it is provided. TI bases its knowledge and belief on information provided by third parties, and makes no representation or warranty as to the accuracy of such information. Efforts are underway to better integrate information from third parties. TI has taken and continues to take reasonable steps to provide representative and accurate information but may not have conducted destructive testing or chemical analysis on incoming materials and chemicals. TI and TI suppliers consider certain information to be proprietary, and thus CAS numbers and other limited information may not be available for release.

In no event shall TI's liability arising out of such information exceed the total purchase price of the TI part(s) at issue in this document sold by TI to Customer on an annual basis.

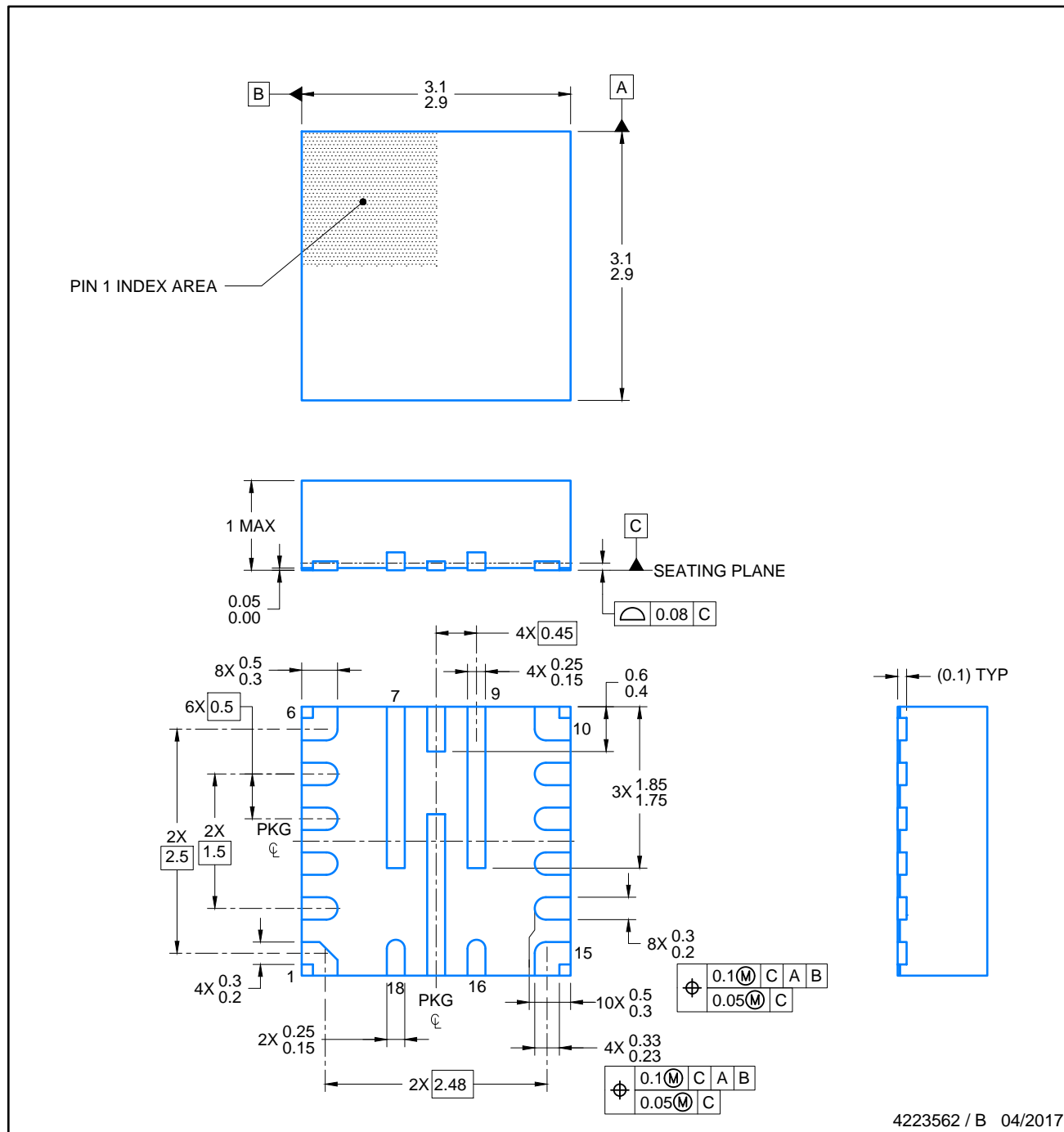

NOTES:

1. All linear dimensions are in millimeters. Any dimensions in parenthesis are for reference only. Dimensioning and tolerancing per ASME Y14.5M.
2. This drawing is subject to change without notice.

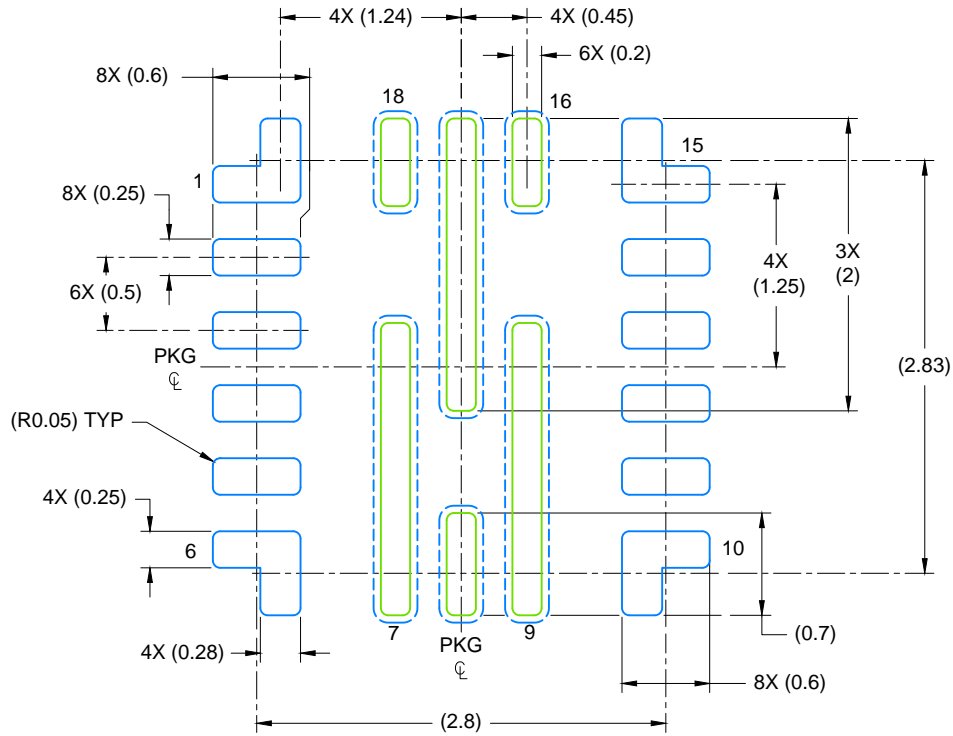

LAND PATTERN EXAMPLE

EXPOSED METAL SHOWN
SCALE: 20X

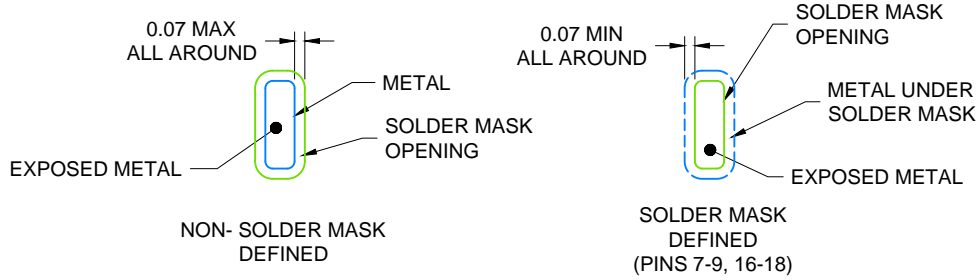

SOLDER MASK DETAILS

4223562 / B 04/2017

NOTES: (continued)

3. For more information, see Texas Instruments literature number SLUA271 (www.ti.com/lit/slua271).
4. Solder mask tolerances between and around signal pads can vary based on board fabrication site.

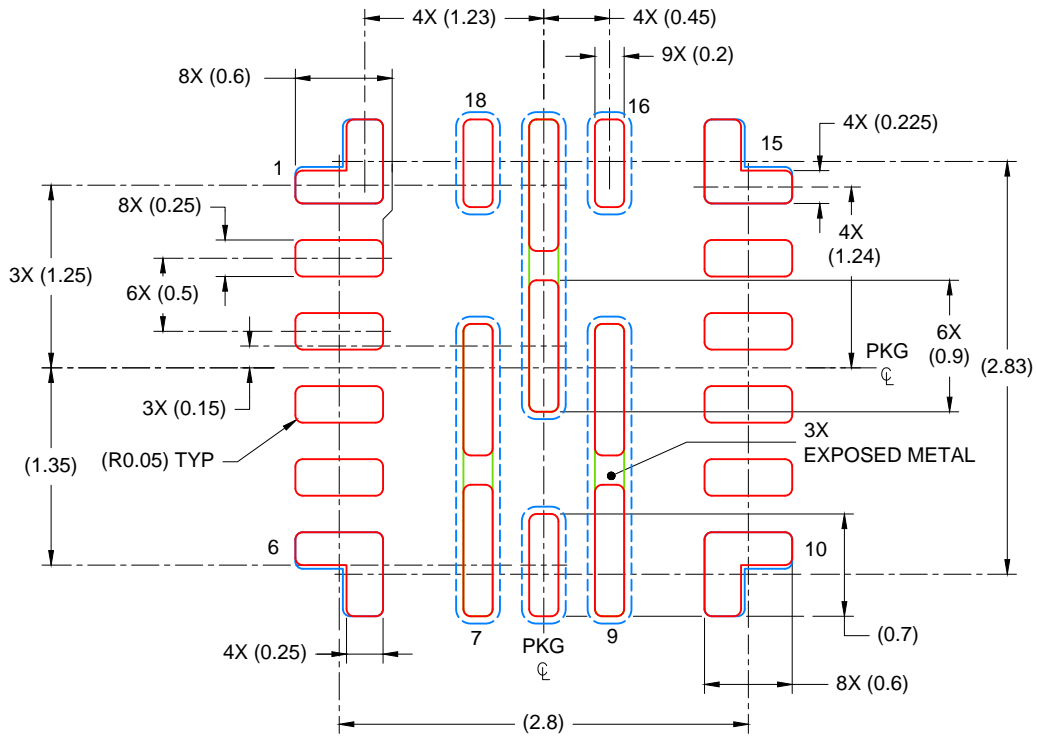

SOLDER PASTE EXAMPLE
 BASED ON 0.1 mm THICK STENCIL

PRINTED SOLDER COVERAGE BY AREA UNDER PACKAGE
 PADS 1, 6, 10 & 15: 93% & PADS 7-9, 17: 89%
 SCALE: 20X

4223562 / B 04/2017

NOTES: (continued)

5. Laser cutting apertures with trapezoidal walls and rounded corners may offer better paste release. IPC-7525 may have alternate design recommendations..

IMPORTANT NOTICE AND DISCLAIMER

TI PROVIDES TECHNICAL AND RELIABILITY DATA (INCLUDING DATASHEETS), DESIGN RESOURCES (INCLUDING REFERENCE DESIGNS), APPLICATION OR OTHER DESIGN ADVICE, WEB TOOLS, SAFETY INFORMATION, AND OTHER RESOURCES "AS IS" AND WITH ALL FAULTS, AND DISCLAIMS ALL WARRANTIES, EXPRESS AND IMPLIED, INCLUDING WITHOUT LIMITATION ANY IMPLIED WARRANTIES OF MERCHANTABILITY, FITNESS FOR A PARTICULAR PURPOSE OR NON-INFRINGEMENT OF THIRD PARTY INTELLECTUAL PROPERTY RIGHTS.

These resources are intended for skilled developers designing with TI products. You are solely responsible for (1) selecting the appropriate TI products for your application, (2) designing, validating and testing your application, and (3) ensuring your application meets applicable standards, and any other safety, security, or other requirements. These resources are subject to change without notice. TI grants you permission to use these resources only for development of an application that uses the TI products described in the resource. Other reproduction and display of these resources is prohibited. No license is granted to any other TI intellectual property right or to any third party intellectual property right. TI disclaims responsibility for, and you will fully indemnify TI and its representatives against, any claims, damages, costs, losses, and liabilities arising out of your use of these resources.

TI's products are provided subject to TI's Terms of Sale (www.ti.com/legal/termsofsale.html) or other applicable terms available either on ti.com or provided in conjunction with such TI products. TI's provision of these resources does not expand or otherwise alter TI's applicable warranties or warranty disclaimers for TI products.

Mailing Address: Texas Instruments, Post Office Box 655303, Dallas, Texas 75265
Copyright © 2019, Texas Instruments Incorporated