

TPS65263-1Q1 4.0- to 18-V Input Voltage, 3-A/2-A/2-A Output Current Triple Synchronous Step-Down Converter With I²C Controlled Dynamic Voltage Scaling

1 Features

- Qualified for Automotive Applications
- AEC-Q100 Qualification With the Following Results:
 - Device Temperature Grade 1: –40°C to 125°C Operating Junction Temperature Range
 - Device HBM ESD Classification Level H2
 - Device CDM ESD Classification Level C4B
- Operating Input Voltage Range 4.0- to 18-V
Maximum Continuous Output Current 3 A/2 A/2 A
- I²C Controlled 7-Bits VID Programmable Output Voltage from 0.68 to 1.95 V With 10-mV Voltage Step for Buck2
- I²C Controlled VID Voltage Transition Slew Rate for Buck2
- I²C Read Back Power Good Status, Overcurrent Warning and Die Temperature Warning
- I²C Compatible Interface With Standard Mode (100 kHz) and Fast Mode (400 kHz)
- Feedback Reference Voltage 0.6 V ±1%
- Adjustable Clock Frequency from 200 kHz to 2.3 MHz
- FCC Mode (Default)
- External Clock Synchronization
- Dedicated Enable and Soft-Start Pins for Each Buck
- Output Voltage Power Good Indicator
- Thermal Overloading Protection

2 Applications

- Automotive
- Car Audio/Video
- Home Gateway and Access Point Networks
- Surveillance

3 Description

The TPS65263-1Q1 incorporates triple-synchronous buck converters with 4.0- to 18-V wide input voltage. The converter with constant frequency peak current mode is designed to simplify its application while giving designers options to optimize the system according to targeted applications. The switching frequency of the converters is adjustable from 200 kHz to 2.3 MHz with an external resistor. 180° out-of-phase operation between buck1 and buck2, buck3 (buck2 and buck3 run in phase) minimizes the input filter requirements.

The initial startup voltage of each buck can be set with external feedback resistors. The output voltage of buck2 can be dynamically scaled from 0.68 to 1.95 V in 10-mV steps with I²C-controlled 7 bits VID. The VID voltage transition slew rate is programmable with 3-bits control through I²C bus to optimize overshoot/undershoot during VID voltage transition.

Each buck in TPS65263-1Q1 can be I²C controlled for enabling/disabling output voltage, setting the pulse skipping mode (PSM) or forced continuous current (FCC) mode at light load condition and reading the power-good status, overcurrent warning, and die temperature warning.

The TPS65263-1Q1 features overvoltage, overcurrent, short-circuit, and overtemperature protection.

Device Information⁽¹⁾

PART NUMBER	PACKAGE	BODY SIZE (NOM)
TPS65263-1Q1	VQFN (32)	5.00 mm x 5.00 mm

(1) For all available packages, see the orderable addendum at the end of the data sheet.

Application Schematic

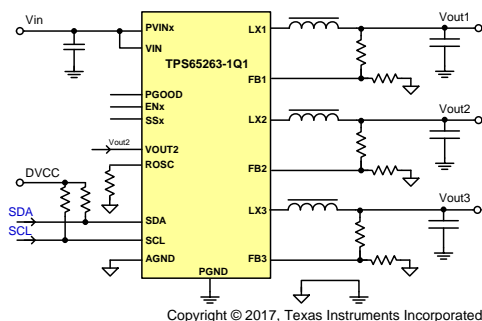

Efficiency vs Output Load

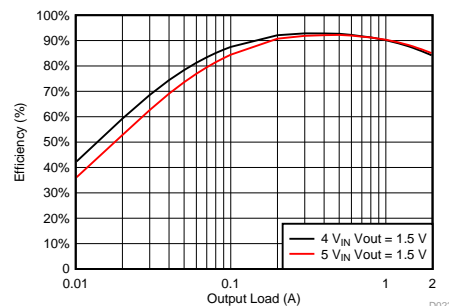

Table of Contents

1 Features	1	7.4 Device Functional Modes	24
2 Applications	1	7.5 Register Maps	26
3 Description	1	8 Application and Implementation	29
4 Revision History	2	8.1 Application Information	29
5 Pin Configuration and Functions	3	8.2 Typical Application	29
6 Specifications	5	9 Power Supply Recommendations	37
6.1 Absolute Maximum Ratings	5	10 Layout	37
6.2 ESD Ratings	5	10.1 Layout Guidelines	37
6.3 Recommended Operating Conditions	5	10.2 Layout Example	38
6.4 Thermal Information	5	11 Device and Documentation Support	39
6.5 Electrical Characteristics	6	11.1 Receiving Notification of Documentation Updates	39
6.6 Typical Characteristics	8	11.2 Community Resources	39
7 Detailed Description	12	11.3 Trademarks	39
7.1 Overview	12	11.4 Electrostatic Discharge Caution	39
7.2 Functional Block Diagram	13	11.5 Glossary	39
7.3 Feature Description	13	12 Mechanical, Packaging, and Orderable Information	39

4 Revision History

DATE	REVISION	NOTES
March 2017	*	Initial release.

5 Pin Configuration and Functions

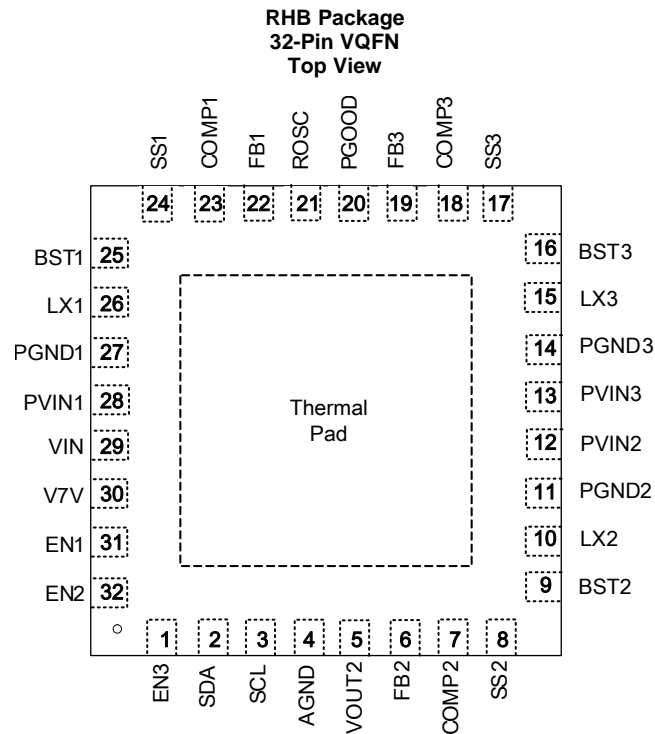

There is no electric signal down bonded to thermal pad inside IC. Exposed thermal pad must be soldered to PCB for optimal thermal performance.

Pin Functions

PIN		DESCRIPTION
NAME	NO.	
EN3	1	Enable for buck3. Float to enable. Can use this pin to adjust the input UVLO of buck3 with a resistor divider.
SDA	2	I ² C interface data pin; float or connect to GND to disable I ² C communication
SCL	3	I ² C interface clock pin; float or connect to GND to disable I ² C communication
AGND	4	Analog ground common to buck controllers and other analog circuits. It must be routed separately from high-current power grounds to the (–) terminal of bypass capacitor of input voltage VIN.
VOUT2	5	Buck2 output voltage sense pin
FB2	6	Feedback Kelvin sensing pin for buck2 output voltage. Connect this pin to buck2 resistor divider.
COMP2	7	Error amplifier output and loop compensation pin for buck2. Connect a series resistor and capacitor to compensate the control loop of buck2 with peak current PWM mode.
SS2	8	Soft-start and tracking input for buck2. An internal 5.2- μ A pullup current source is connected to this pin. The soft-start time can be programmed by connecting a capacitor between this pin and ground.
BST2	9	Boot-strapped supply to the high-side floating gate driver in buck2. Connect a capacitor (recommend 47 nF) from BST2 pin to LX2 pin.
LX2	10	Switching node connection to the inductor and bootstrap capacitor for buck2. The voltage swing at this pin is from a diode voltage below the ground up to PVIN2 voltage.
PGND2	11	Power ground connection of buck2. Connect PGND2 pin as close as practical to the (–) terminal of VIN2 input ceramic capacitor.
PVIN2	12	Input power supply for buck2. Connect PVIN2 pin as close as practical to the (+) terminal of an input ceramic capacitor (suggest 10 μ F).
PVIN3	13	Input power supply for buck3. Connect PVIN3 pin as close as practical to the (+) terminal of an input ceramic capacitor (suggest 10 μ F).
PGND3	14	Power ground connection of buck3. Connect PGND3 pin as close as practical to the (–) terminal of VIN3 input ceramic capacitor.

Pin Functions (continued)

PIN		DESCRIPTION
NAME	NO.	
LX3	15	Switching node connection to the inductor and bootstrap capacitor for buck3. The voltage swing at this pin is from a diode voltage below the ground up to PVIN3 voltage.
BST3	16	Boot-strapped supply to the high-side floating gate driver in buck3. Connect a capacitor (recommend 47 nF) from BST3 pin to LX3 pin.
SS3	17	Soft-start and tracking input for buck3. An internal 5.2- μ A pullup current source is connected to this pin. The soft-start time can be programmed by connecting a capacitor between this pin and ground.
COMP3	18	Error amplifier output and loop compensation pin for buck3. Connect a series resistor and capacitor to compensate the control loop of buck3 with peak current PWM mode.
FB3	19	Feedback Kelvin sensing pin for buck3 output voltage. Connect this pin to buck3 resistor divider.
PGOOD	20	Output voltage supervision pin. When all bucks are in PGOOD monitor's regulation range, PGOOD is asserted high.
ROSC	21	Clock frequency adjustment pin. Connect a resistor from this pin to ground to adjust the clock frequency. When connected to an external clock, the internal oscillator synchronizes to the external clock.
FB1	22	Feedback Kelvin sensing pin for buck1 output voltage. Connect this pin to buck1 resistor divider.
COMP1	23	Error amplifier output and loop compensation pin for buck1. Connect a series resistor and capacitor to compensate the control loop of buck1 with peak current PWM mode.
SS1	24	Soft-start and tracking input for buck1. An internal 5.2- μ A pullup current source is connected to this pin. The soft-start time can be programmed by connecting a capacitor between this pin and ground.
BST1	25	Boot-strapped supply to the high-side floating gate driver in buck1. Connect a capacitor (recommend 47 nF) from BST1 pin to LX1 pin.
LX1	26	Switching node connection to the inductor and bootstrap capacitor for buck1. The voltage swing at this pin is from a diode voltage below the ground up to PVIN1 voltage.
PGND1	27	Power ground connection of buck1. Connect PGND1 pin as close as practical to the (–) terminal of VIN1 input ceramic capacitor.
PVIN1	28	Input power supply for buck1. Connect PVIN1 pin as close as practical to the (+) terminal of an input ceramic capacitor (suggest 10 μ F).
VIN	29	Buck controller power supply
V7V	30	Internal LDO for gate driver and internal controller. Connect a 1- μ F capacitor from the pin to power ground.
EN1	31	Enable for buck1. Float to enable. Can use this pin to adjust the input UVLO of buck1 with a resistor divider.
EN2	32	Enable for buck2. Float to enable. Can use this pin to adjust the input UVLO of buck2 with a resistor divider.
PAD	—	There is no electric signal down bonded to thermal pad inside IC. Exposed thermal pad must be soldered to PCB for optimal thermal performance.

6 Specifications

6.1 Absolute Maximum Ratings

over operating free-air temperature (unless otherwise noted) ⁽¹⁾

	MIN	MAX	UNIT
PVIN1, PVIN2, PVIN3, VIN	-0.3	20	V
LX1, LX2, LX3 (Maximum withstand voltage transient < 20 ns)	-1.0	20	V
BST1, BST2, BST3 referenced to LX1, LX2, LX3 pins respectively	-0.3	7	V
EN1, EN2, EN3, V7V, VOUT2, SCL, SDA, PGOOD	-0.3	7	V
FB1, FB2, FB3, COMP1, COMP2, COMP3, ROSC, SS1, SS2, SS3	-0.3	3.6	V
AGND, PGND1, PGND2, PGND3	-0.3	0.3	V
T _J Operating junction temperature	-40	150	°C
T _{stg} Storage temperature	-55	150	°C

- (1) Stresses beyond those listed under *Absolute Maximum Ratings* may cause permanent damage to the device. These are stress ratings only, which do not imply functional operation of the device at these or any other conditions beyond those indicated under *Recommended Operating Conditions*. Exposure to absolute-maximum-rated conditions for extended periods may affect device reliability.

6.2 ESD Ratings

			VALUE	UNIT
V _(ESD) Electrostatic discharge	Human body model (HBM), per ANSI/ESDA/JEDEC JS-001, all -2000 2000 pins ⁽¹⁾		±2000	V
	Charged device model (CDM), per JEDEC specification JESD22-C101, all pins ⁽²⁾		±500	

- (1) JEDEC document JEP155 states that 500-V HBM allows safe manufacturing with a standard ESD control process.
(2) JEDEC document JEP157 states that 250-V CDM allows safe manufacturing with a standard ESD control process.

6.3 Recommended Operating Conditions

over operating free-air temperature range (unless otherwise noted)

	MIN	MAX	UNIT
PVIN1, PVIN2, PVIN3, VIN	4	18	V
LX1, LX2, LX3 (Maximum withstand voltage transient <20 ns)	-0.8	18	V
BST1, BST2, BST3 referenced to LX1, LX2, LX3 pins respectively	-0.1	6.8	V
EN1, EN2, EN3, V7V, VOUT1, VOUT2, VOUT3, SCL, SDA	-0.1	6.3	V
FB1, FB2, FB3, COMP1, COMP2, COMP3, SS1, SS2, SS3	-0.1	3	V
T _J Operating junction temperature	-40	125	°C

6.4 Thermal Information

THERMAL METRIC ⁽¹⁾		TPS65263-1Q1	
		RHB (VQFN)	
		32 PINS	
R _{θJA}	Junction-to-ambient thermal resistance	33.3	°C/W
R _{θJC(top)}	Junction-to-case (top) thermal resistance	25.7	°C/W
R _{θJB}	Junction-to-board thermal resistance	7.4	°C/W
ψ _{JT}	Junction-to-top characterization parameter	0.3	°C/W
ψ _{JB}	Junction-to-board characterization parameter	7.3	°C/W
R _{θJC(bot)}	Junction-to-case (bottom) thermal resistance	2.1	°C/W

- (1) For more information about traditional and new thermal metrics, see the *Semiconductor and IC Package Thermal Metrics* application report, [SPRA953](#).

6.5 Electrical Characteristics

 $V_{IN} = 12\text{ V}$, $F_{SW} = 500\text{ kHz}$, $T_J = -40^\circ\text{C}$ to 125°C , typical values are at $T_J = 25^\circ\text{C}$ (unless otherwise noted)

PARAMETER		TEST CONDITIONS	MIN	TYP	MAX	UNIT
INPUT SUPPLY VOLTAGE						
VIN	Input voltage range		4		18	V
UVLO	VIN UVLO	VIN rising	3.5	3.8	4	V
		VIN falling	3.1	3.3	3.5	V
		Hysteresis		500		mV
IDDSN	Shutdown supply current	EN1 = EN2 = EN3 = 0 V	4	9.5	18	μA
IDDQ_NSW	Input quiescent current without buck1/2/3 switching	EN1 = EN2 = EN3 = 5 V, FB1 = FB2 = FB3 = 0.8 V	550	780	1150	μA
IDDQ_NSW1		EN1 = 5 V, EN2 = EN3 = 0 V, FB1 = 0.8 V	180	370	590	μA
IDDQ_NSW2		EN2 = 5 V, EN1 = EN3 = 0 V, FB2 = 0.8 V	180	370	590	μA
IDDQ_NSW3		EN3 = 5 V, EN1 = EN2 = 0 V, FB3 = 0.8 V	180	370	590	μA
V7V	V7V LDO output voltage	V7V load current = 0 A		6.3		V
I _{OCP_V7V}	V7V LDO current limit		78	185	260	mA
FEEDBACK VOLTAGE REFERENCE						
V _{FB}	Feedback voltage	V _{COMP} = 1.2 V	0.594	0.6	0.606	V
BUCK1, BUCK2, BUCK3						
V _{ENXH}	EN1/2/3 high-level input voltage		1.12	1.2	1.26	V
V _{ENXL}	EN1/2/3 low-level input voltage		1.05	1.15	1.21	V
I _{ENX1}	EN1/2/3 pullup current	ENx = 1 V	2.5	3.9	5.9	μA
I _{ENX2}	EN1/2/3 pullup current	ENx = 1.5 V	5.1	6.9	9.2	μA
I _{ENhys}	Hysteresis current		2.6	3	3.3	μA
I _{SSX}	Soft-start charging current		3.9	5.2	6.5	μA
t _{ON_MIN}	Minimum on-time		50	75	110	ns
G _{m_EA}	Error amplifier transconductance	-2 μA < I _{COMPX} < 2 μA	140	300	450	μs
G _{m_PS1/2/3}	COMP1/2/3 voltage to inductor current G _m ⁽¹⁾	I _{LX} = 0.5 A		7.4		A/V
I _{LIMIT1}	Buck1 peak inductor current limit		4.3	5.4	6.5	A
I _{LIMITSINK1}	Buck1 low-side sink current limit		0.7	1.3	1.8	A
I _{LIMIT2/3}	Buck2/buck3 peak inductor current limit		2.55	3.3	3.9	A
I _{LIMITSINK2/3}	Buck2/buck3 low-side sink current limit		0.5	1	1.4	A
R _{dson_HS1}	Buck1 high-side switch resistance	VIN = 12 V		105		mΩ
R _{dson_LS1}	Buck1 low-side switch resistance	VIN = 12 V		65		mΩ
R _{dson_HS2}	Buck2 high-side switch resistance	VIN = 12 V		140		mΩ
R _{dson_LS2}	Buck2 low-side switch resistance	VIN = 12 V		90		mΩ
R _{dson_HS3}	Buck3 high-side switch resistance	VIN = 12 V		140		mΩ
R _{dson_LS3}	Buck3 low-side switch resistance	VIN = 12 V		90		mΩ
HICCUP TIMING						
t _{Hiccup_wait}	Overcurrent wait time ⁽¹⁾			256		cycles
t _{Hiccup_re}	Hiccup time before restart ⁽¹⁾			8192		cycles
POWER GOOD						
V _{th_PG}	Feedback voltage threshold	FBx undervoltage falling		92.5		%V _{REF}
		FBx undervoltage rising		95		
		FBx overvoltage rising		107.5		
		FBx overvoltage falling		105		
t _{DEGLITCH(PG)_F}	PGOOD falling edge deglitch time			112		cycles
t _{DEGLITCH(PG)_R}	PGOOD rising edge deglitch time			616		cycles
I _{PG}	PGOOD pin leakage				0.1	μA
V _{LOW_PG}	PGOOD pin low voltage	I _{SINK} = 1 mA		0.4		V

(1) Lab validation result

Electrical Characteristics (continued)

$V_{IN} = 12\text{ V}$, $F_{SW} = 500\text{ kHz}$, $T_J = -40^\circ\text{C}$ to 125°C , typical values are at $T_J = 25^\circ\text{C}$ (unless otherwise noted)

PARAMETER		TEST CONDITIONS	MIN	TYP	MAX	UNIT
OSCILLATOR						
F_{SW}	Switching frequency	$R_{OSC} = 88.7\text{ k}\Omega$	430	500	560	kHz
F_{SW_range}	Switching frequency		200		2300	kHz
T_{SYNC_w}	Clock sync minimum pulse width		80			ns
F_{SYNC_HI}	Clock sync high threshold				2	V
V_{SYNC_LO}	Clock sync low threshold		0.4			V
F_{SYNC}	Clock sync frequency range		200		2300	kHz
THERMAL PROTECTION						
T_{TRIP_OTP}	Thermal protection trip point ⁽¹⁾	Temperature rising		160		$^\circ\text{C}$
T_{HYST_OTP}		Hysteresis		20		$^\circ\text{C}$
I²C INTERFACE						
Addr	Address ⁽²⁾	0x60H				
$V_{IH\ SDA,SCL}$	Input high voltage				2	V
$V_{IL\ SDA,SCL}$	Input low voltage		0.4			V
I_I	Input current	SDA, SCL, $V_I = 0.4$ to 4.5 V	-10		10	μA
$V_{OL\ SDA}$	SDA output low voltage	SDA open drain, $I_{OL} = 4\text{ mA}$			0.4	V
$f_{(SCL)}$	Maximum SCL clock frequency ⁽²⁾		400			kHz
t_{BUF}	Bus free time between a STOP and START condition ⁽²⁾		1.3			μs
t_{HD_STA}	Hold time (repeated) START condition ⁽²⁾		0.6			μs
t_{SU_STO}	Setup time for STOP condition ⁽²⁾		0.6			μs
t_{LOW}	Low period of the SCL clock ⁽²⁾		1.3			μs
t_{HIGH}	High period of the SCL clock ⁽²⁾		0.6			μs
t_{SU_STA}	Setup time for a repeated START condition ⁽²⁾		0.6			μs
t_{SU_DAT}	Data setup time ⁽²⁾		0.1			μs
t_{HD_DAT}	Data hold time ⁽²⁾		0		0.9	μs
t_{RCL}	Rise time of SCL signal ⁽²⁾	Capacitance of one bus line (pF)	$20 + 0.1C_B$		300	ns
t_{RCL1}	Rise time of SCL signal after a repeated START condition and after an acknowledge bit ⁽²⁾	Capacitance of one bus line (pF)	$20 + 0.1C_B$		300	ns
t_{FCL}	Fall time of SCL signal ⁽²⁾	Capacitance of one bus line (pF)	$20 + 0.1C_B$		300	ns
t_{RDA}	Rise time of SDA signal ⁽²⁾	Capacitance of one bus line (pF)	$20 + 0.1C_B$		300	ns
t_{FDA}	Fall time of SDA signal ⁽²⁾	Capacitance of one bus line (pF)	$20 + 0.1C_B$		300	ns
C_B	Capacitance of bus line(SCL and SDA) ⁽²⁾				400	pF

(2) Not production tested

6.6 Typical Characteristics

$T_A = 25^\circ\text{C}$, $V_{IN} = 12\text{ V}$, $V_{OUT1} = 1.5\text{ V}$, $V_{OUT2} = 1.2\text{ V}$, $V_{OUT3} = 2.5\text{ V}$, $F_{SW} = 500\text{ kHz}$ (unless otherwise noted)

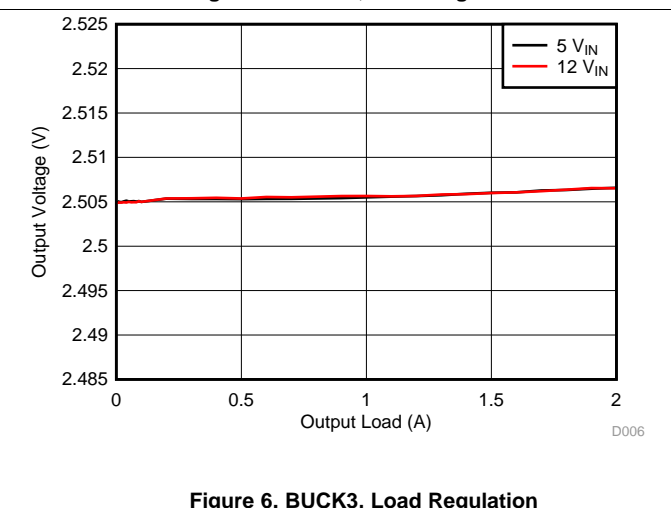
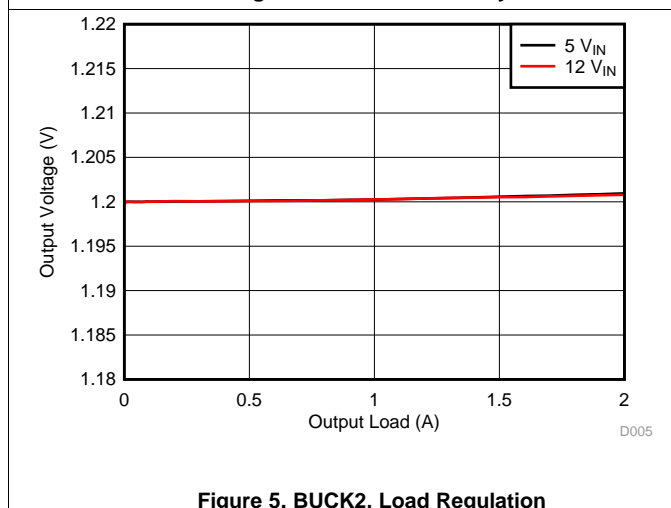
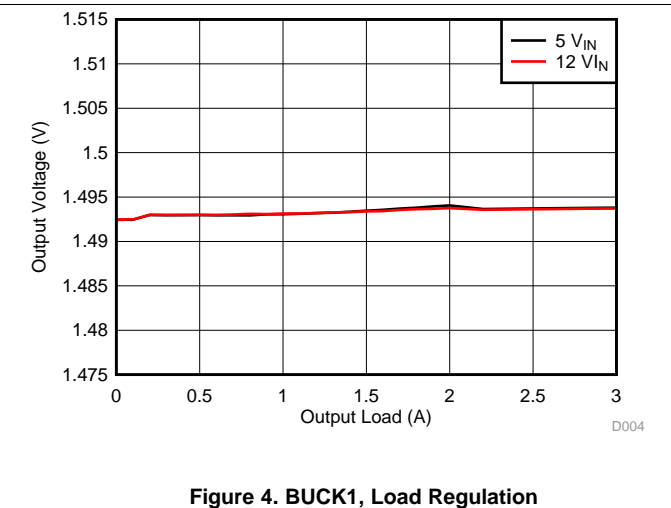
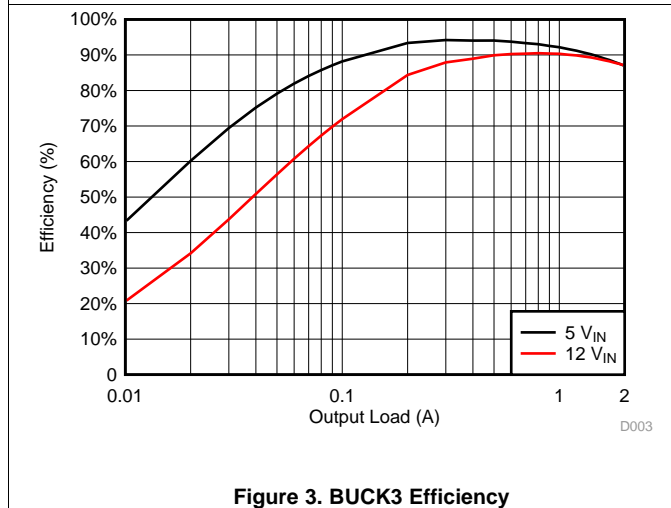
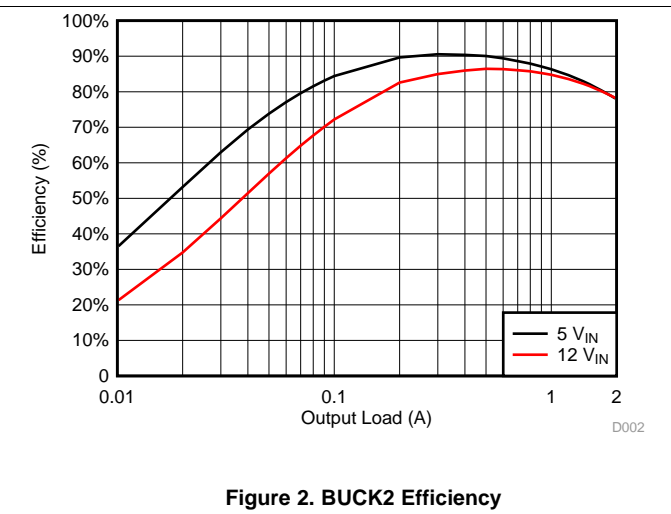
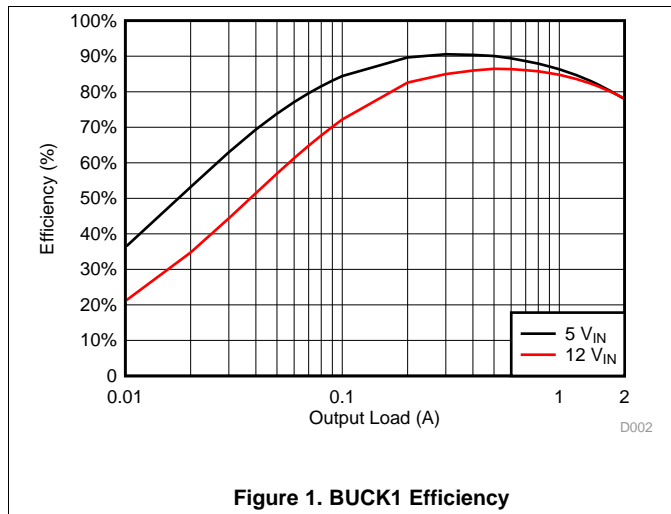

Typical Characteristics (continued)

$T_A = 25^\circ\text{C}$, $V_{IN} = 12\text{ V}$, $V_{OUT1} = 1.5\text{ V}$, $V_{OUT2} = 1.2\text{ V}$, $V_{OUT3} = 2.5\text{ V}$, $F_{SW} = 500\text{ kHz}$ (unless otherwise noted)

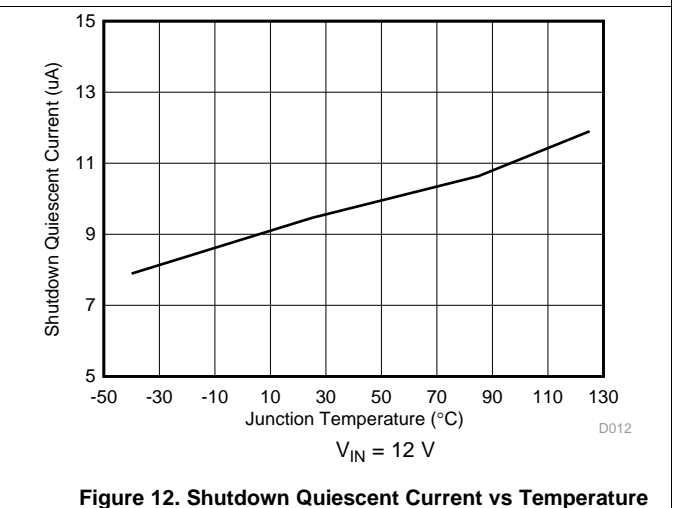
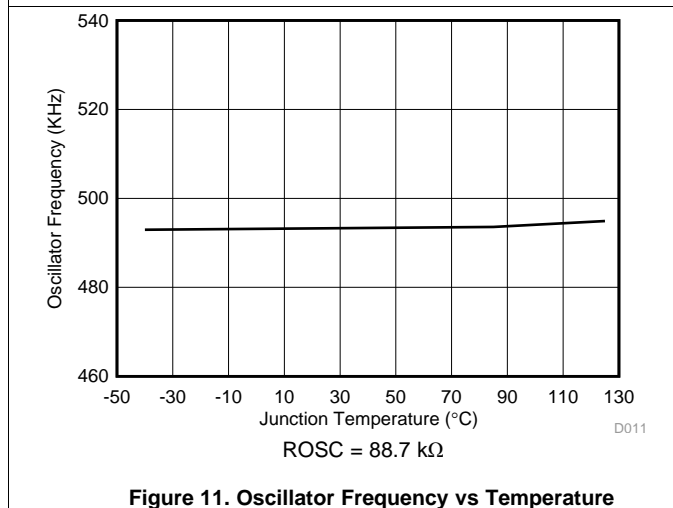
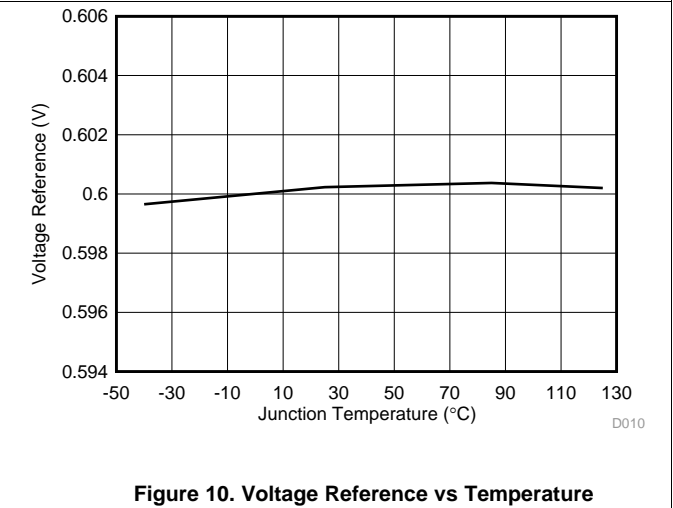
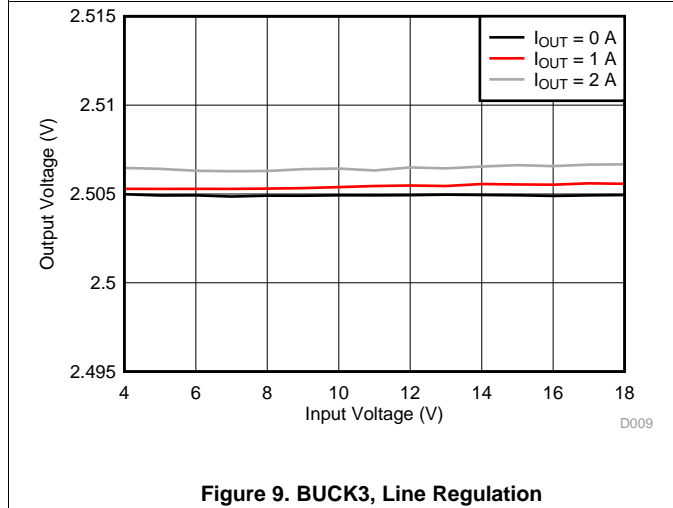
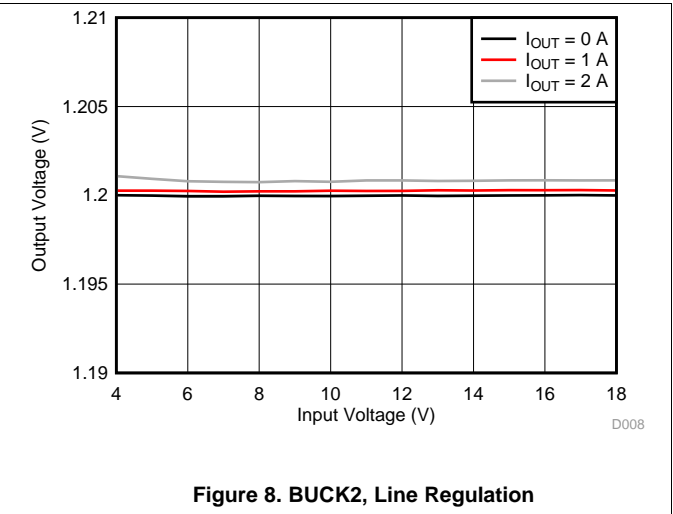
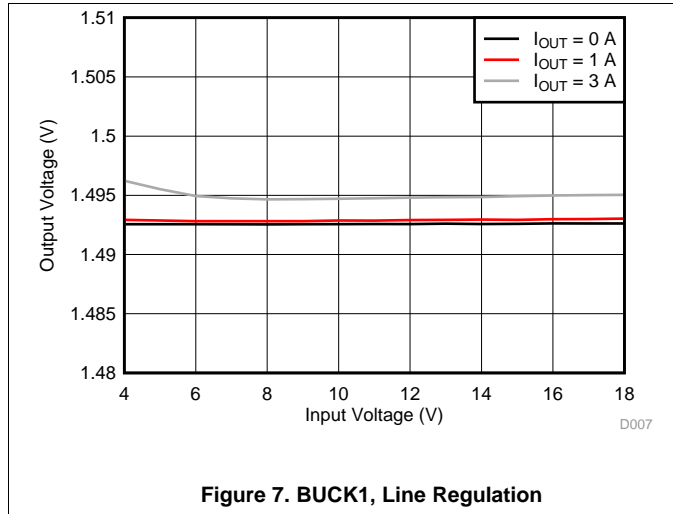

Typical Characteristics (continued)

$T_A = 25^\circ\text{C}$, $V_{IN} = 12\text{ V}$, $V_{OUT1} = 1.5\text{ V}$, $V_{OUT2} = 1.2\text{ V}$, $V_{OUT3} = 2.5\text{ V}$, $F_{SW} = 500\text{ kHz}$ (unless otherwise noted)

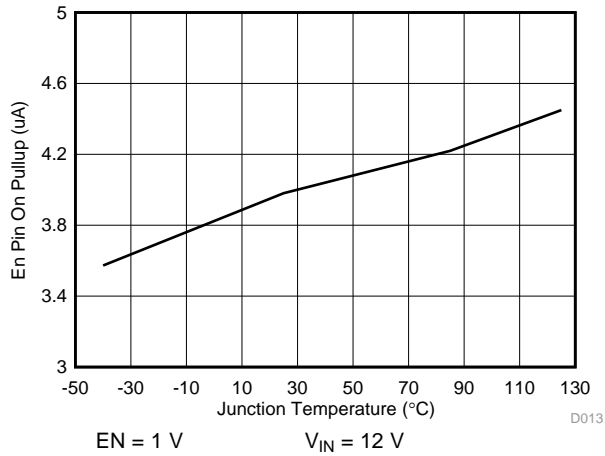

Figure 13. EN Pin Pullup Current vs Temperature, EN = 1.0 V

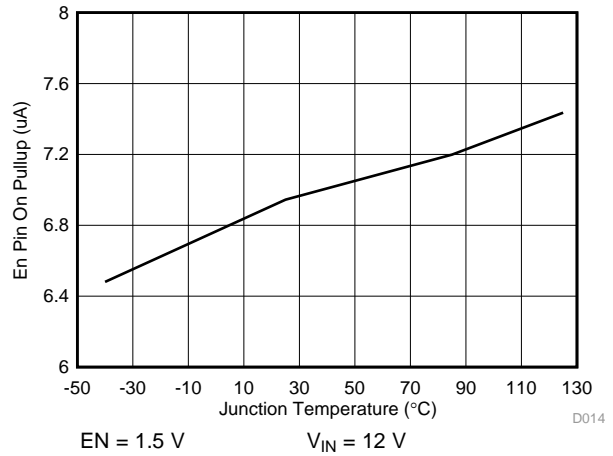

Figure 14. EN Pin Pullup Current vs Temperature, EN = 1.5 V

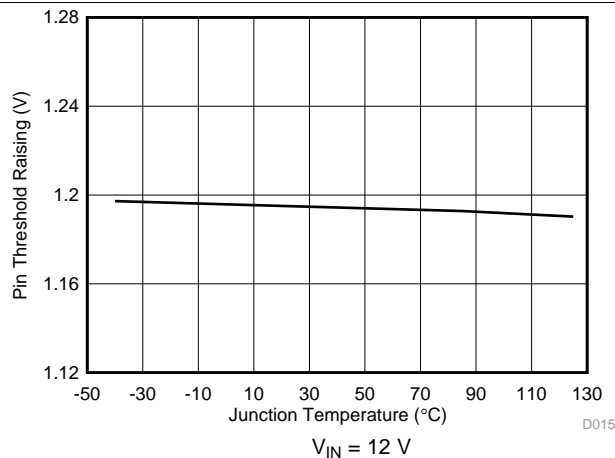

Figure 15. EN Pin Threshold Rising vs Temperature

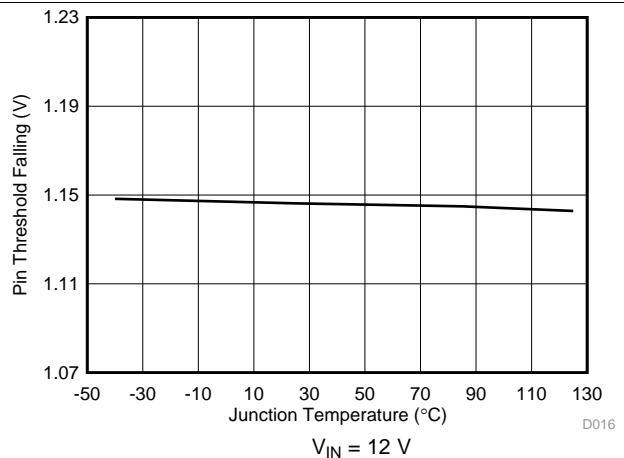

Figure 16. EN Pin Threshold Falling vs Temperature

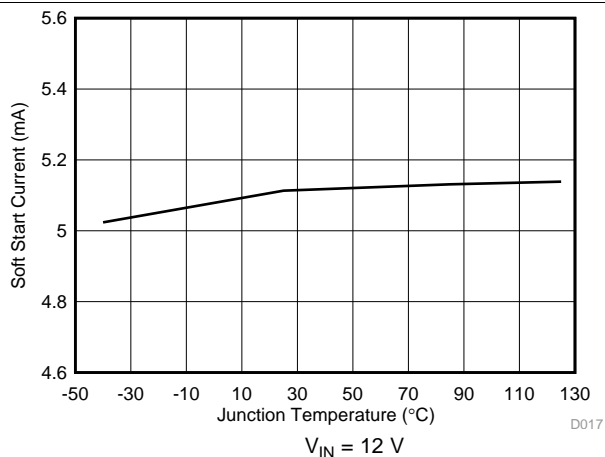

Figure 17. SS Pin Charge Current vs Temperature

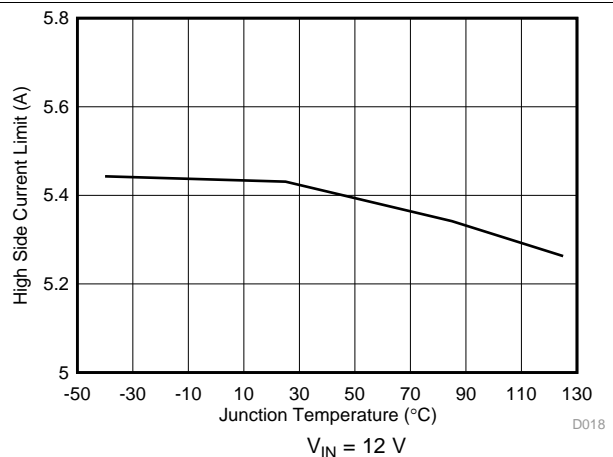
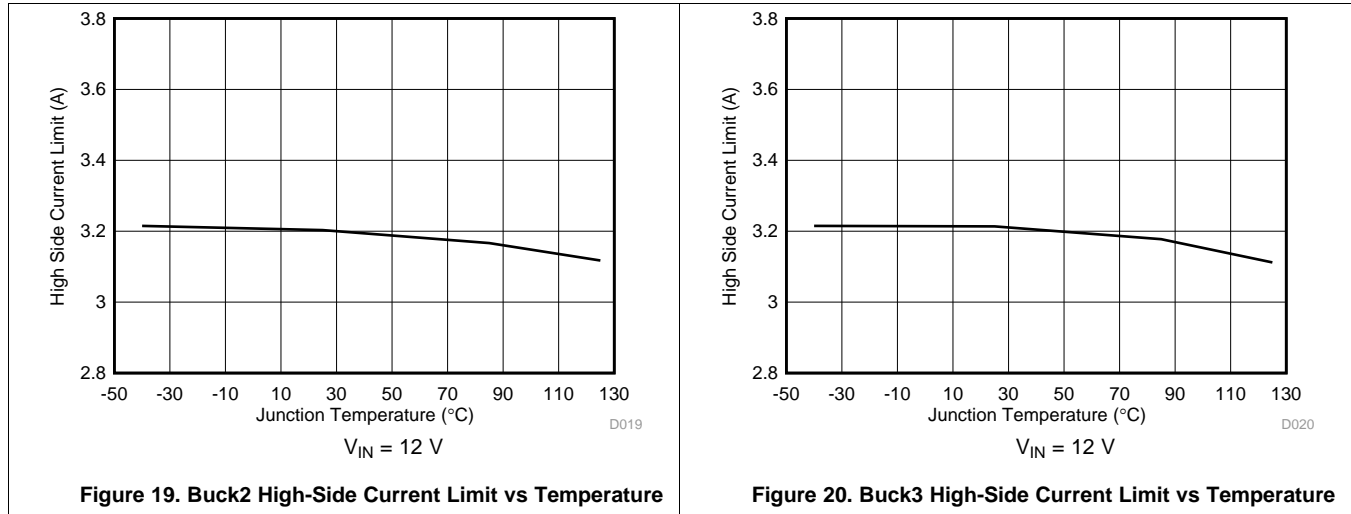

Figure 18. Buck1 High-Side Current Limit vs Temperature

Typical Characteristics (continued)

$T_A = 25^\circ\text{C}$, $V_{IN} = 12\text{ V}$, $V_{OUT1} = 1.5\text{ V}$, $V_{OUT2} = 1.2\text{ V}$, $V_{OUT3} = 2.5\text{ V}$, $F_{SW} = 500\text{ kHz}$ (unless otherwise noted)



7 Detailed Description

7.1 Overview

The TPS65263-1Q1 is a monolithic, triple-synchronous step-down (buck) converter with 3-A/2-A/2-A output currents. A wide 4- to 18-V input supply voltage range encompasses most intermediate bus voltages operating off 5-, 9-, 12-, or 15-V power bus. The feedback voltage reference for each buck is 0.6 V. Each buck is independent with dedicated enable, soft-start, and loop compensation pins.

The TPS65263-1Q1 is equipped with an I²C compatible bus for communication with SoC to control buck converters. Through the I²C interface, SoC can enable or disable the buck converters, set output voltage (BUCK2 only), and read status registers. External feedback divider resistors can set the initial start-up voltage of the buck2. After the voltage identification VID DAC is updated via the I²C, output voltage of the buck2 can be independently programmed with 7 bits VID from 0.68 to 1.95 V in 10-mV voltage step resolution. Output voltage of the buck2 transition begins after the I²C interface receives the command for the GO bit in the command register.

If SDA and SCL pins are floated or are connected to GND, the I²C communication will be rejected and the TPS65263-1Q1 will operate as a traditional triple buck. Each buck on or off is separately controlled by the relevant enable pin. Buck2's output voltage is set with the external feedback divider resistors.

In the light load condition, the converter operates at continuous current mode (CCM) with a fixed frequency for optimized output ripple. PSM can be enabled through I2C so that the converter automatically operates in pulse skipping mode (PSM) to save power.

The TPS65263-1Q1 implements a constant frequency, peak current mode control that simplifies external loop compensation. The wide switching frequency of 200 kHz to 2.3 MHz allows for optimizing system efficiency, filtering size, and bandwidth. The switching frequency can be adjusted with an external resistor connecting between the ROSC pin and ground. The TPS65263-1Q1 also has an internal phase locked loop (PLL) controlled by the ROSC pin that can be used to synchronize the switching cycle to the falling edge of an external system clock. The switching clock of buck1 is 180° out-of-phase operation from the clocks of buck2 and buck3 channels to reduce input current ripple, input capacitor size, and power-supply-induced noise.

The TPS65263-1Q1 is designed for safe monotonic startup into prebiased loads. The default startup is when VIN is typically 3.8 V. The ENx pin can also be used to adjust the input voltage undervoltage lockout (UVLO) with an external resistor divider. In addition, the ENx pin has an internal 3.9- μ A current source, so the EN pin can be floating for automatically powering up the converters.

The TPS65263-1Q1 reduces the external component count by integrating the bootstrap circuit. The bias voltage for the integrated high-side MOSFET is supplied by a capacitor between the BST and LX pins. A UVLO circuit monitors the bootstrap capacitor voltage $V_{BST}-V_{LX}$ in each buck. When $V_{BST}-V_{LX}$ voltage drops to the threshold, LX pin is pulled low to recharge the bootstrap capacitor. The TPS65263-1Q1 can operate at 100% duty cycle as long as the bootstrap capacitor voltage is higher than the BOOT-LX UVLO threshold, which is typically 2.1 V.

The TPS65263-1Q1 has power-good comparators with hysteresis, which monitor the output voltages through internal feedback voltages. I²C can read the power-good status with the command register. The device also features the PGOOD pin to supervise output voltages of the buck converter. When all bucks are in regulation range and power sequence is done, PGOOD is asserted high.

The SS (soft-start/tracking) pin is used to minimize inrush currents or provide power-supply sequencing during power up. A small value capacitor or resistor divider is connected to the pin for soft start or voltage tracking.

The TPS65263-1Q1 is protected from overload and overtemperature fault conditions. The converter minimizes excessive output overvoltage transients by taking advantage of the power-good comparator. When the output is over, the high-side MOSFET is turned off until the internal feedback voltage is lower than 105% of the 0.6-V reference voltage. The TPS65263-1Q1 implements both high-side MOSFET overload protection and bidirectional low-side MOSFET overload protections to avoid inductor current runaway. If the overcurrent condition has lasted for more than the OC wait time (256 clock cycle), the converter shuts down and restarts after the hiccup time (8192 clock cycles). The TPS65263-1Q1 shuts down if the junction temperature is higher than thermal shutdown trip point. When the junction temperature drops 20°C typically below the thermal shutdown trip point, the TPS65263-1Q1 is restarted under control of the soft-start circuit automatically.

7.2 Functional Block Diagram

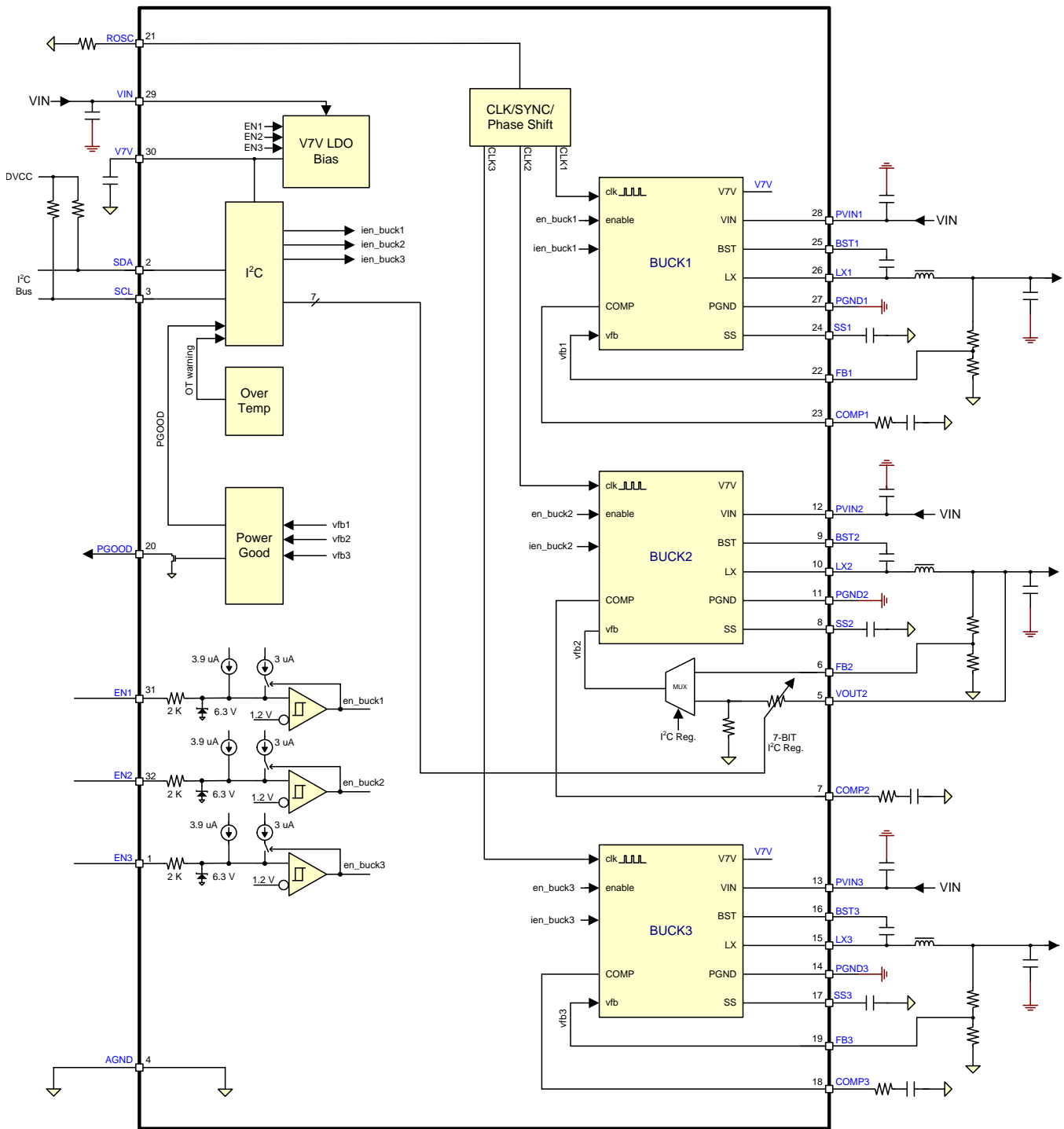

Copyright © 2017, Texas Instruments Incorporated

7.3 Feature Description

7.3.1 Adjusting the Output Voltage

The output voltage of each buck is set with a resistor divider from the output of buck to the FB pin. TI recommends to use 1% tolerance or better resistors.

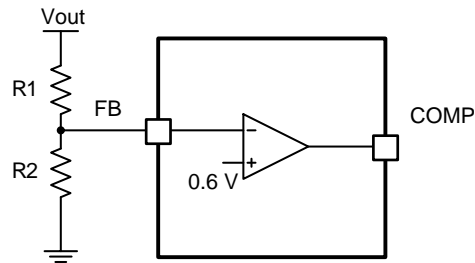
Feature Description (continued)

Figure 21. Voltage Divider Circuit

$$R_2 = R_1 \times \frac{0.6}{V_{\text{out}} - 0.6} \quad (1)$$

To improve efficiency at light loads consider using larger value resistors. If the values are too high, the regulator is more sensitive to noise. [Table 1](#) shows the recommended resistor values.

Table 1. Output Resistor Divider Selection

OUTPUT VOLTAGE (V)	R1 (kΩ)	R2 (kΩ)
1	10	15
1.2	10	10
1.5	15	10
1.8	20	10
2.5	31.6	10
3.3	45.3	10
3.3	22.6	4.99
5	73.2	10
5	36.5	4.99

The output voltage of the buck converter can be dynamically scaled by I²C-controlled 7-bit register, VOUTx_SEL. Before I²C communication, the output voltage is set with the resistor divider from the output of buck to the FB pin. When the GO bit is set to 1 through the I²C interface, the buck converter switches the external resistor divider to the internal resistor divider as shown in [Figure 22](#). The output voltage can be selected among 128 voltages with voltage identifications (VID) shown in [Table 2](#). The output voltage range of dynamic voltage scaling is 0.68 to 1.95 V with 10-mV resolution of each voltage step.

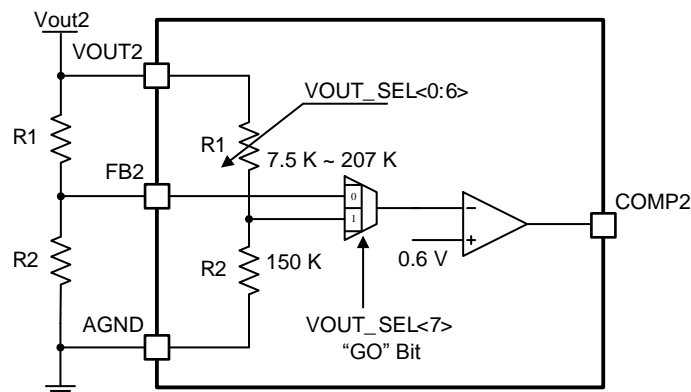

Figure 22. Voltage Divider Circuit

Table 2. V_{OUT} Output Voltage Setting

OUT_SEL <7:0>	V _{OUT} (V)	VOUT_SEL <7:0>	V _{OUT} (V)	VOUT_SEL <7:0>	V _{OUT} (V)	VOUT_SEL <7:0>	V _{OUT} (V)
0	0.68	20	1	40	1.32	60	1.64
1	0.69	21	1.01	41	1.33	61	1.65
2	0.7	22	1.02	42	1.34	62	1.66
3	0.71	23	1.03	43	1.35	63	1.67
4	0.72	24	1.04	44	1.36	64	1.68
5	0.73	25	1.05	45	1.37	65	1.69
6	0.74	26	1.06	46	1.38	66	1.7
7	0.75	27	1.07	47	1.39	67	1.71
8	0.76	28	1.08	48	1.4	68	1.72
9	0.77	29	1.09	49	1.41	69	1.73
A	0.78	2A	1.1	4A	1.42	6A	1.74
B	0.79	2B	1.11	4B	1.43	6B	1.75
C	0.8	2C	1.12	4C	1.44	6C	1.76
D	0.81	2D	1.13	4D	1.45	6D	1.77
E	0.82	2E	1.14	4E	1.46	6E	1.78
F	0.83	2F	1.15	4F	1.47	6F	1.79
10	0.84	30	1.16	50	1.48	70	1.8
11	0.85	31	1.17	51	1.49	71	1.81
12	0.86	32	1.18	52	1.5	72	1.82
13	0.87	33	1.19	53	1.51	73	1.83
14	0.88	34	1.2	54	1.52	74	1.84
15	0.89	35	1.21	55	1.53	75	1.85
16	0.9	36	1.22	56	1.54	76	1.86
17	0.91	37	1.23	57	1.55	77	1.87
18	0.92	38	1.24	58	1.56	78	1.88
19	0.93	39	1.25	59	1.57	79	1.89
1A	0.94	3A	1.26	5A	1.58	7A	1.9
1B	0.95	3B	1.27	5B	1.59	7B	1.91
1C	0.96	3C	1.28	5C	1.6	7C	1.92
1D	0.97	3D	1.29	5D	1.61	7D	1.93
1E	0.98	3E	1.3	5E	1.62	7E	1.94
1F	0.99	3F	1.31	5F	1.63	7F	1.95

7.3.2 Enable and Adjusting UVLO

The ENx pin provides electrical on and off control of the device. After the ENx pin voltage exceeds the threshold voltage, the device starts operation. If each ENx pin voltage is pulled below the threshold voltage, the regulator stops switching and enters a low Iq state.

The EN pin has an internal pullup current source, allowing the user to float the EN pin for enabling the device. If an application requires controlling the EN pin, use open-drain or open-collector output logic to interface with the pin.

The device implements internal UVLO circuitry on the VIN pin. The device is disabled when the VIN pin voltage falls below the internal VIN UVLO threshold. The internal VIN UVLO threshold has a hysteresis of 500 mV. If an application requires either a higher UVLO threshold on the VIN pin or a secondary UVLO on the PVINx in split rail applications, then the user can configure the ENx pin as shown in [Figure 23](#), [Figure 24](#), and [Figure 25](#). When using the external UVLO function, TI recommends to set the hysteresis >500 mV.

The EN pin has a small pullup current, I_p , which sets the default state of the pin to enable when no external components are connected. The pullup current is also used to control the voltage hysteresis for the UVLO function because it increases by I_h after the EN pin crosses the enable threshold. The UVLO thresholds can be calculated using [Equation 2](#) and [Equation 3](#).

$$R_1 = \frac{V_{\text{START}} \left(\frac{V_{\text{ENFALLING}}}{V_{\text{ENRISING}}} \right) - V_{\text{STOP}}}{I_p \left(1 - \frac{V_{\text{ENFALLING}}}{V_{\text{ENRISING}}} \right) + I_h} \quad (2)$$

$$R_2 = \frac{R_1 \times V_{\text{ENFALLING}}}{V_{\text{STOP}} - V_{\text{ENFALLING}} + R_1 (I_h + I_p)}$$

where

- $I_h = 3 \mu\text{A}$
- $I_p = 3.9 \mu\text{A}$
- $V_{\text{ENRISING}} = 1.2 \text{ V}$
- $V_{\text{ENFALLING}} = 1.15 \text{ V}$

(3)

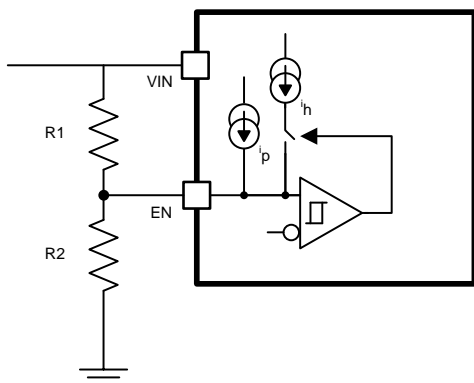

Figure 23. Adjustable VIN UVLO

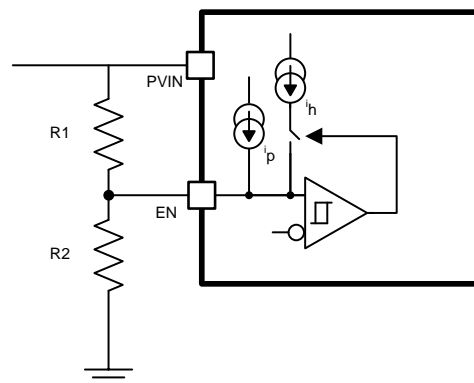

Figure 24. Adjustable PVIN UVLO, VIN > 4 V

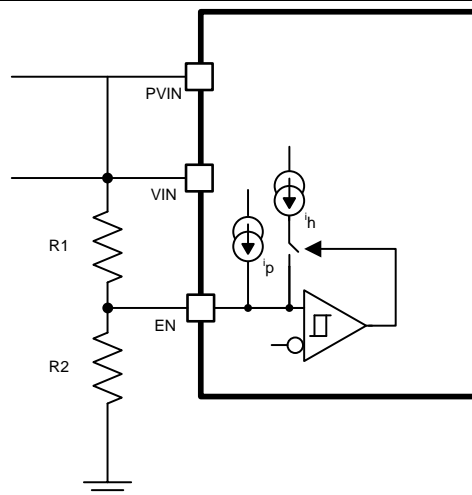

Figure 25. Adjustable VIN and PVIN UVLO

7.3.3 Soft-Start Time

The voltage on the respective SS pin controls the startup of buck output. When the voltage on the SS pin is less than the internal 0.6-V reference, The TPS65263-1Q1 regulates the internal feedback voltage to the voltage on the SS pin instead of 0.6 V. The SS pin can be used to program an external soft-start function or to allow output of buck to track another supply during start-up. The device has an internal pullup current source of 5.2 μA (typical) that charges an external soft-start capacitor to provide a linear ramping voltage at the SS pin. The TPS65263-1Q1 regulates the internal feedback voltage to the voltage on the SS pin, allowing VOUT to rise smoothly from 0 V to its regulated voltage without inrush current. The soft-start time can be calculated approximately by Equation 4.

$$T_{ss}(\text{ms}) = \frac{C_{ss}(\text{nF}) \times V_{ref}(\text{V})}{I_{ss}(\mu\text{A})} \quad (4)$$

Many of the common power-supply sequencing methods can be implemented using the SSx and ENx pins. Figure 26 shows the method implementing ratiometric sequencing by connecting the SSx pins of three buck channels together. The regulator outputs ramp up and reach regulation at the same time. When calculating the soft-start time, the pullup current source must be tripled in Equation 4.

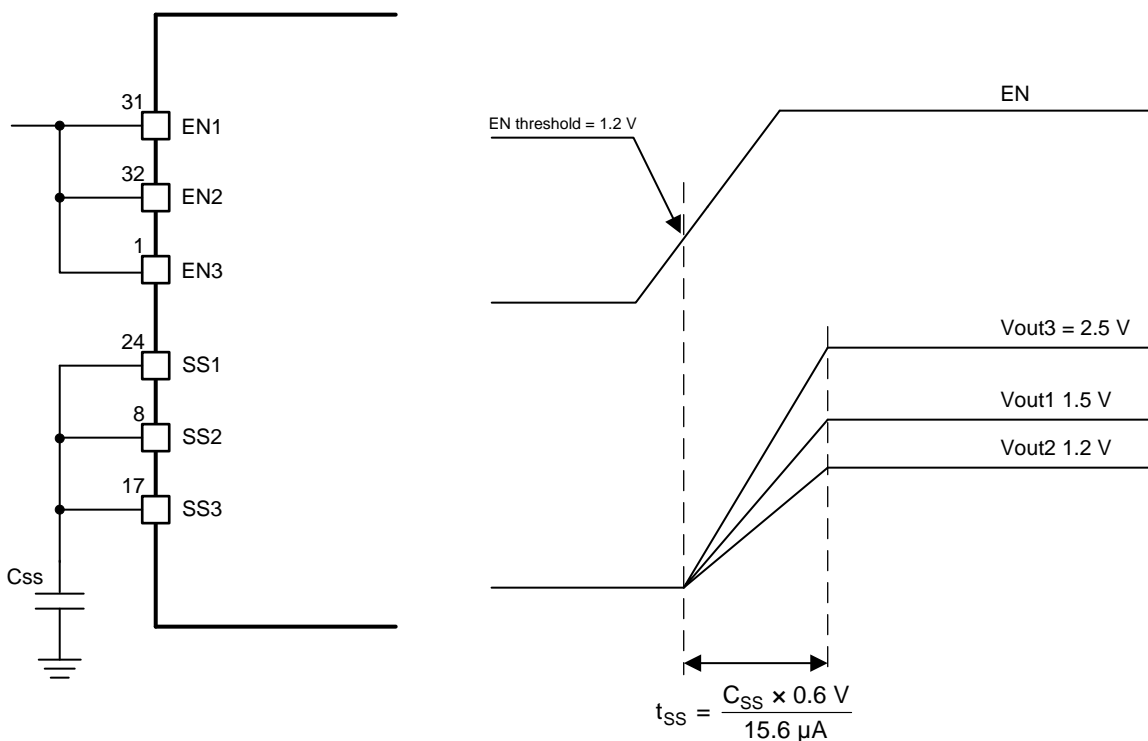

Figure 26. Ratiometric Power-Up Using SSx Pins

The user can implement simultaneous power-supply sequencing by connecting the capacitor to the SSx pin, shown in Figure 27. Using Equation 4 and Equation 5, the capacitors can be calculated.

$$\frac{C_{ss1}}{V_{out1}} = \frac{C_{ss2}}{V_{out2}} = \frac{C_{ss3}}{V_{out3}} \quad (5)$$

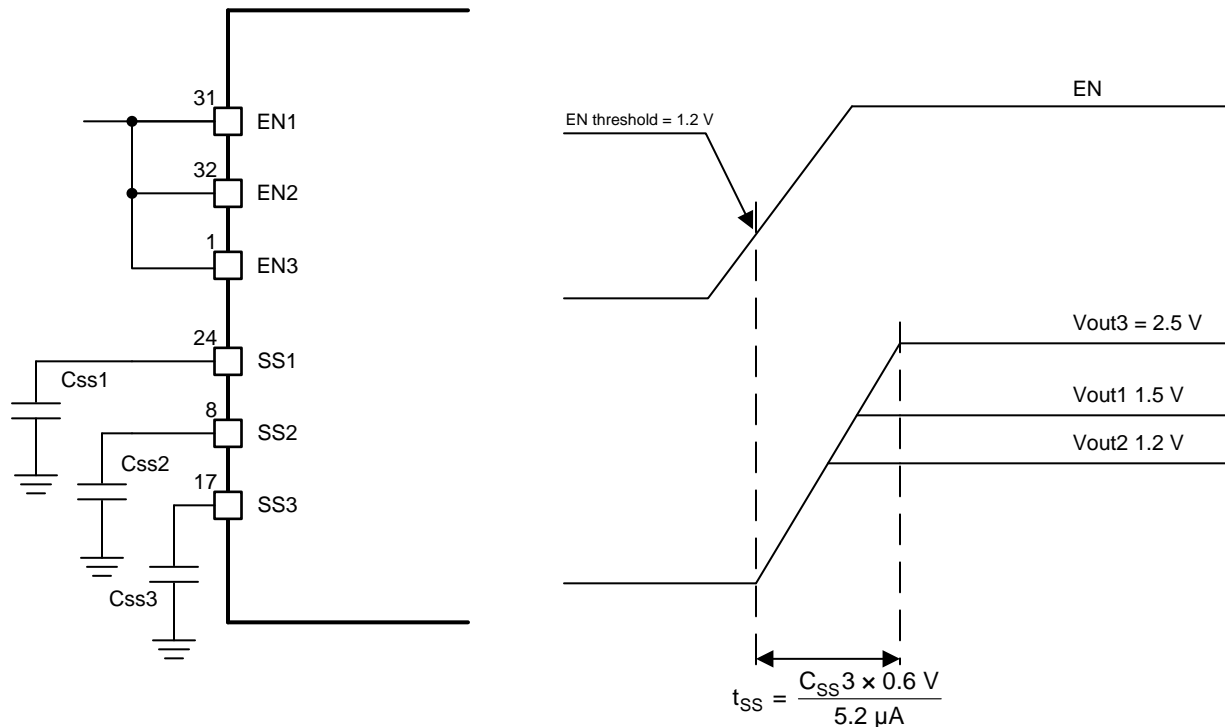

Figure 27. Simultaneous Startup Sequence Using SSx Pins

7.3.4 Power-Up Sequencing

The TPS65263-1Q1 has a dedicated enable pin and soft-start pin for each converter. The converter enable pins are biased by a current source that allows for easy sequencing by the addition of an external capacitor. Disabling the converter with an active pulldown transistor on the ENx pin allows for predictable power-down timing operation. Figure 28 shows the timing diagram of a typical buck power-up sequence with connecting a capacitor at the ENx pin.

A typical 1.4-µA current is charging the ENx pin from input supply. When the ENx pin voltage rises to typical 0.4 V, the internal V7V LDO turns on. A 3.9-µA pullup current is sourcing ENx. After the ENx pin voltage reaches the ENx enabling threshold, a 3.0-µA hysteresis current sources to the pin to improve noise sensitivity. The internal soft-start comparator compares the SS pin voltage to 1.2 V. When the SS pin voltage ramps up to 1.2 V, PGOOD monitor is enabled. After PGOOD deglitch time, PGOOD is deasserted. The SS pin voltage is eventually clamped around 2.1 V.

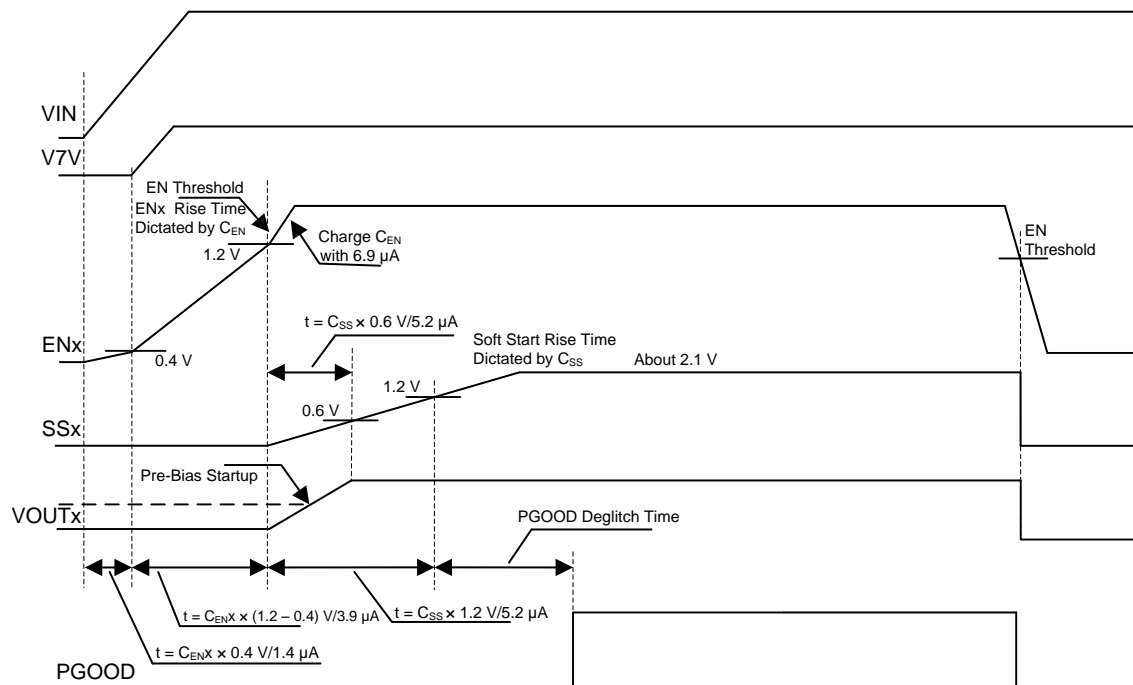

Figure 28. Startup Power Sequence

7.3.5 V7V Low-Dropout Regulator and Bootstrap

Power for the high-side and low-side MOSFET drivers and most other internal circuitry is derived from the V7V pin. The internal built-in low-dropout linear regulator (LDO) supplies 6.3 V (typical) from VIN to V7V. The user should connect a 1- μF ceramic capacitor from V7V pin to power ground.

If the input voltage, VIN, decreases to the UVLO threshold voltage, the UVLO comparator detects the V7V pin voltage and forces the converter off.

Each high-side MOSFET driver is biased from the floating bootstrap capacitor, CB, shown in Figure 29, which is normally recharged during each cycle through an internal low-side MOSFET or the body diode of a low-side MOSFET when the high-side MOSFET turns off. The boot capacitor is charged when the BST pin voltage is less than VIN and BST-LX voltage is below regulation. TI recommends a 47-nF ceramic capacitor. TI recommends a ceramic capacitor with an X7R or X5R grade dielectric with a voltage rating of 10 V or higher because of the stable characteristics over temperature and voltage. Each low-side MOSFET driver is powered from the V7V pin directly.

To improve dropout, the device is designed to operate at 100% duty cycle as long as the BST to LX pin voltage is greater than the BST-LX UVLO threshold, which is typically 2.1 V. When the voltage between BST and LX drops below the BST-LX UVLO threshold, the high-side MOSFET is turned off and the low-side MOSFET is turned on allowing the boot capacitor to be recharged.

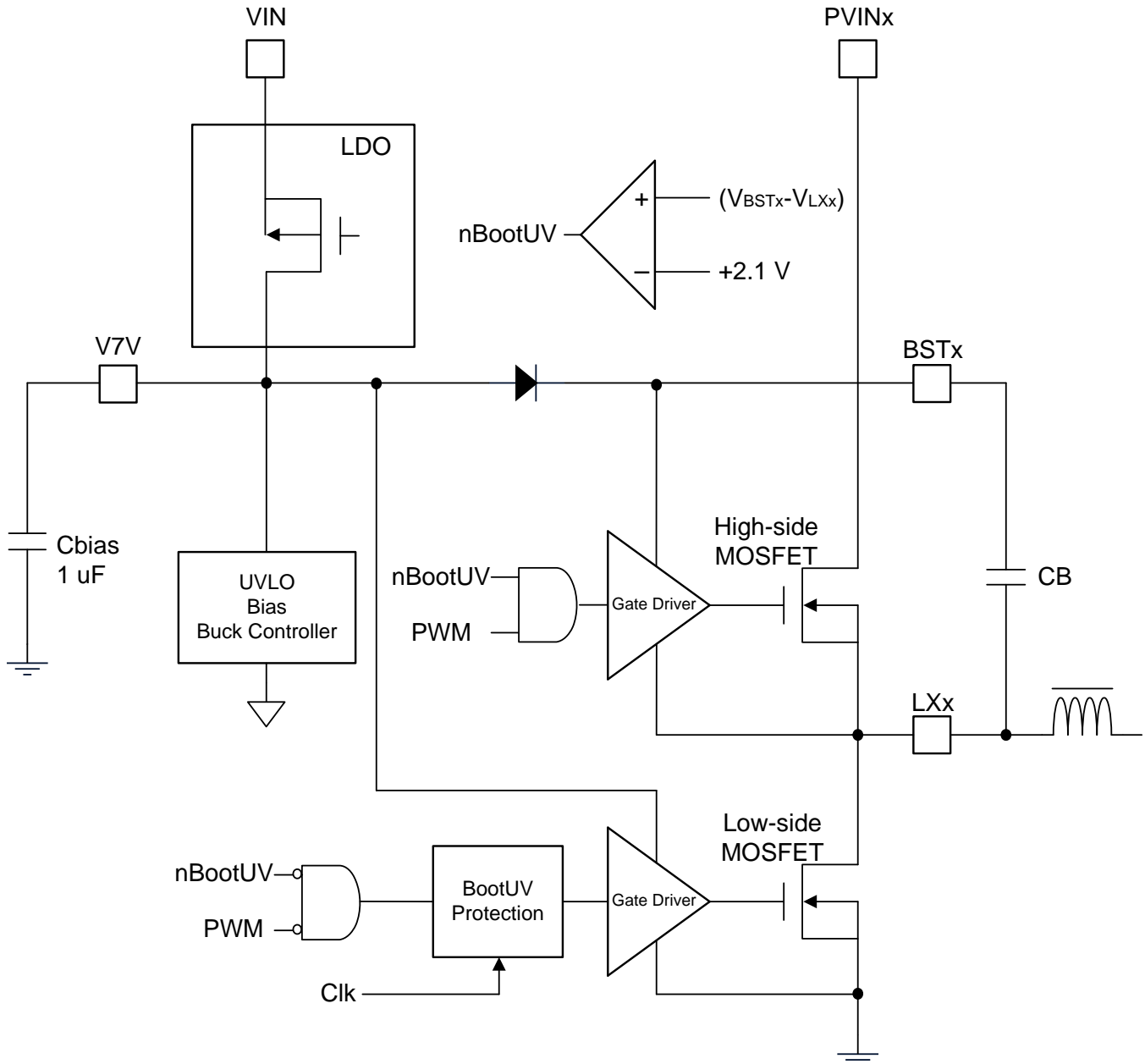

Figure 29. V7V Linear Dropout Regulator and Bootstrap Voltage Diagram

7.3.6 Out-of-Phase Operation

To reduce input ripple current, the switch clock of buck1 is 180° out-of-phase from the clock of buck2 and buck3. This enables the system having less input current ripple to reduce input capacitors' size, cost, and EMI.

7.3.7 Output Overvoltage Protection (OVP)

The device incorporates an OVP circuit to minimize output voltage overshoot. When the output is overloaded, the error amplifier compares the actual output voltage to the internal reference voltage. If the FB pin voltage is lower than the internal reference voltage for a considerable time, the output of the error amplifier demands maximum output current. After the condition is removed, the regulator output rises and the error amplifier output transitions to the steady-state voltage. In some applications with small output capacitance, the load can respond faster than the error amplifier. This leads to the possibility of an output overshoot. Each buck compares the FB pin voltage to the OVP threshold. If the FB pin voltage is greater than the OVP threshold, the high-side MOSFET is turned off preventing current from flowing to the output and minimizing output overshoot. When the FB voltage drops lower than the OVP threshold, the high-side MOSFET turns on at the next clock cycle.

7.3.8 PSM

The TPS65263-1Q1 can enter high-efficiency PSM operation at light load current. To enable PSM operation, set the VOUTx_COM registers' bit 1 to '1' through I²C interface.

When a controller is enabled for PSM operation, the peak inductor current is sensed and compared with 310-mA current typically. Because the integrated current comparator catches the peak inductor current only, the average load current entering PSM varies with the applications and external output filters. In PSM, the sensed peak inductor current is clamped at 310 mA, shown in Figure 30.

When a controller operates in PSM, the inductor current is not allowed to reverse. The reverse current comparator turns off the low-side MOSFET when the inductor current reaches 0, preventing it from reversing and going negative.

Due to the delay in the circuit and current comparator, t_{dly} (typical 50 nS at $V_{in} = 12$ V), the real peak inductor current threshold to turn off high-side power MOSFET could shift higher depending on inductor inductance and input/output voltages. Calculate the threshold of peak inductor current to turn off high-side power MOSFET with Equation 6.

$$I_{L_{PEAK}} = 310 \text{ mA} + \frac{V_{in} - V_{out}}{L} \times t_{dly} \quad (6)$$

After the charge accumulated on the Vout capacitor is more than loading need, the COMP pin voltage drops to a low voltage driven by the error amplifier. There is an internal comparator at COMP pin. If the comp voltage is <0.35 V, the power stage stops switching to save power.

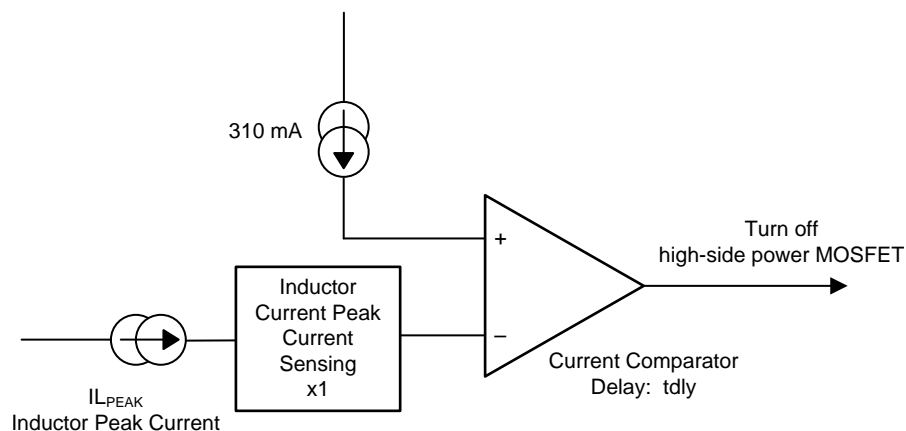

Figure 30. PSM Current Comparator

7.3.9 Slope Compensation

To prevent the subharmonic oscillations when the device operates at duty cycles greater than 50%, the TPS65263-1Q1 adds built-in slope compensation, which is a compensating ramp to the switch current signal.

7.3.10 Overcurrent Protection

The device is protected from overcurrent conditions by cycle-by-cycle current limiting on both the high-side MOSFET and low-side MOSFET.

7.3.10.1 High-Side MOSFET Overcurrent Protection

The device implements current mode control that uses the COMP pin voltage to control the turn off of the high-side MOSFET and the turn on of the low-side MOSFET on a cycle-by-cycle basis. Each cycle the switch current and the current reference generated by the COMP pin voltage are compared, when the peak switch current intersects the current reference, the high-side switch is turned off.

7.3.10.2 Low-Side MOSFET Overcurrent Protection

While the low-side MOSFET is turned on, its conduction current is monitored by the internal circuitry. During normal operation, the low-side MOSFET sources current to the load. At the end of every clock cycle, the low-side MOSFET sourcing current is compared to the internally set low-side sourcing current limit. If the low-side sourcing current is exceeded, the high-side MOSFET is not turned on and the low-side MOSFET stays on for the next cycle. The high-side MOSFET is turned on again when the low-side current is below the low-side sourcing current limit at the start of a cycle.

The low-side MOSFET may also sink current from the load. If the low-side sinking current limit is exceeded, the low-side MOSFET is turned off immediately for the rest of that clock cycle. In this scenario both MOSFETs are off until the start of the next cycle.

Furthermore, if an output overload condition (as measured by the COMP pin voltage) has lasted for more than the hiccup wait time which is programmed for 256 switching cycles shown in Figure 31, the device shuts down and restarts after the hiccup time of 8192 cycles. The hiccup mode helps to reduce the device power dissipation under severe overcurrent condition.

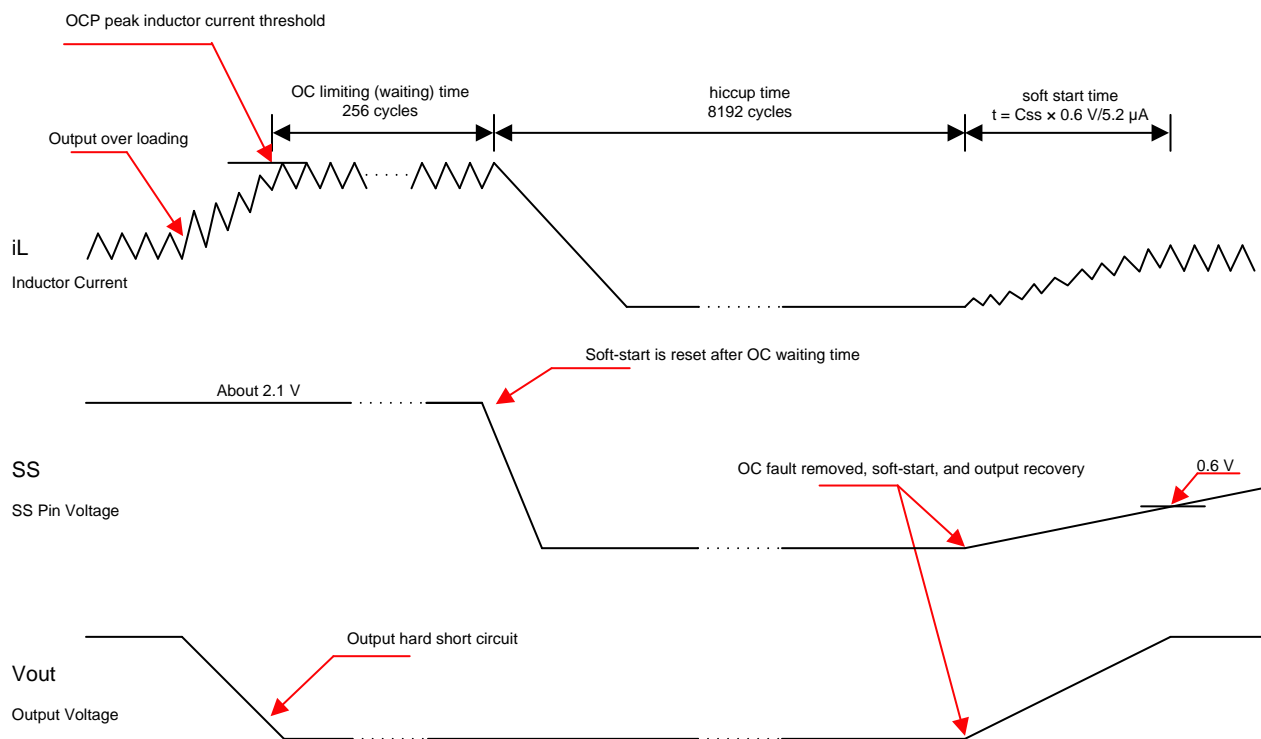

Figure 31. Overcurrent Protection

7.3.11 Power Good

The PGOOD pin is an open-drain output. When feedback voltage of each buck is between 95% (rising) and 105% (falling) of the internal voltage reference, the PGOOD pin pulldown is deasserted and the pin floats. TI recommends to use a pullup resistor between the values of 10 and 100 k Ω to a voltage source that is 5.5 V or less. The PGOOD is in a defined state when the VIN input voltage is greater than 1 V, but with reduced current sinking capability. The PGOOD achieves full current sinking capability after the VIN input voltage is above UVLO threshold, which is 3.8 V.

The PGOOD pin is pulled low when any feedback voltage of buck is lower than 92.5% (falling) or greater than 107.5% (rising) of the nominal internal reference voltage. Also, when the PGOOD is pulled low, if the input voltage is undervoltage locked up, thermal shutdown is asserted, the EN pin is pulled low or the converter is in soft-start period.

The power-good indicator for each buck channel can be read back through I²C. The bits in SYS_STATUS[2:0] (address 0x06H) present the feedback voltage in regulation (logic 1) or not (logic 0) for buck1, buck2, and buck3 respectively

7.3.11.1 Adjustable Switching Frequency

The ROSC pin can be used to set the switching frequency by connecting a resistor to GND. The switching frequency of the device is adjustable from 200 kHz to 2.3 MHz.

To determine the ROSC resistance for a given switching frequency, use Equation 7 or the curve in Figure 32. To reduce the solution size, the user should set the switching frequency as high as possible, but consider tradeoffs of the supply efficiency and minimum controllable on-time.

$$f_{osc} \text{ (kHz)} = 37254 \times R(\text{k}\Omega)^{-0.966} \quad (7)$$

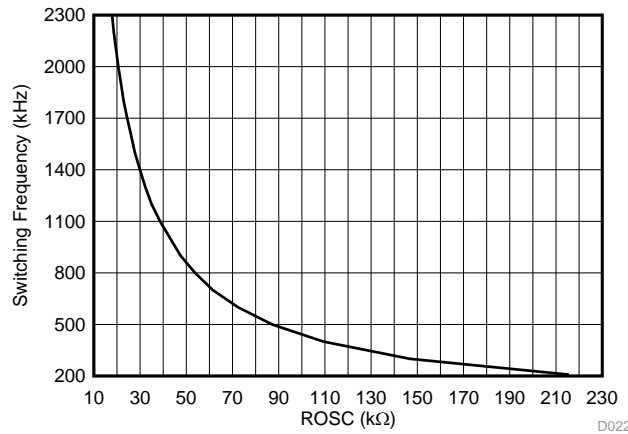

Figure 32. ROSC vs Switching Frequency

When an external clock applies to ROSC pin, the internal PLL has been implemented to allow internal clock synchronizing to an external clock between 200 and 2300 kHz. To implement the clock synchronization feature, connect a square wave clock signal to the ROSC pin with a duty cycle between 20% to 80%. The clock signal amplitude must transition lower than 0.4 V and higher than 2.0 V. The start of the switching cycle is synchronized to the falling edge of ROSC pin.

In applications where both resistor mode and synchronization mode are needed, the user can configure the device as shown in Figure 33. Before an external clock is present, the device works in resistor mode and ROSC resistor sets the switching frequency. When an external clock is present, the synchronization mode overrides the resistor mode. The first time the ROSC pin is pulled above the ROSC high threshold (2.0 V), the device switches from the resistor mode to the synchronization mode and the ROSC pin becomes high impedance as the PLL starts to lock onto the frequency of the external clock. TI does not recommend to switch from the synchronization mode back to the resistor mode because the internal switching frequency drops to 100 kHz first before returning to the switching frequency set by ROSC resistor.

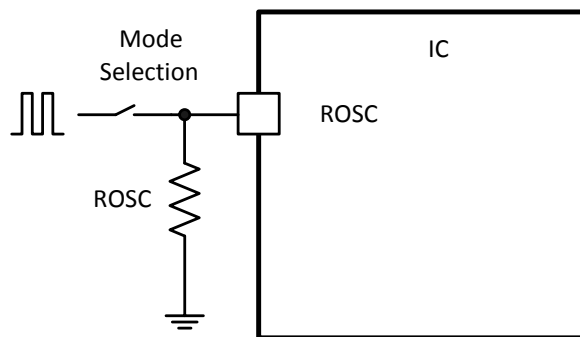

Figure 33. Works With Resistor Mode and Synchronization Mode

7.3.12 Thermal Shutdown

The internal thermal shutdown circuitry forces the device to stop switching if the junction temperature exceeds 160°C typically. The device reinitiates the power-up sequence when the junction temperature drops below 140°C typically.

7.4 Device Functional Modes

7.4.1 Serial Interface Description

I²C is a 2-wire serial interface developed by NXP Semiconductor (see *I²C-Bus Specification, Version 2.1*, January 2000). The bus consists of a data line (SDA) and a clock line (SCL) with pullup structures. When the bus is idle, both SDA and SCL lines are pulled high. All the I²C-compatible devices connect to the I²C bus through open-drain I/O pins, SDA and SCL. A master device, usually a microcontroller or a digital signal processor, controls the bus. The master is responsible for generating the SCL signal and device addresses. The master also generates specific conditions that indicate the START and STOP of data transfer. A slave device receives and/or transmits data on the bus under control of the master device.

The TPS65263-1Q1 device works as a slave and supports the following data transfer modes, as defined in the I²C-Bus Specification: standard mode (100 kbps) and fast mode (400 kbps). The interface adds flexibility to the power-supply solution, enabling most functions to be programmed to new values depending on the instantaneous application requirements. Register contents remain intact as long as supply voltage remains above 3.8 V (typical).

The data transfer protocol for standard and fast modes is exactly the same. Therefore, they are referred to as F/S-mode in this document. The TPS65263-1Q1 device supports 7-bit addressing. 10-bit addressing and general call address are not supported.

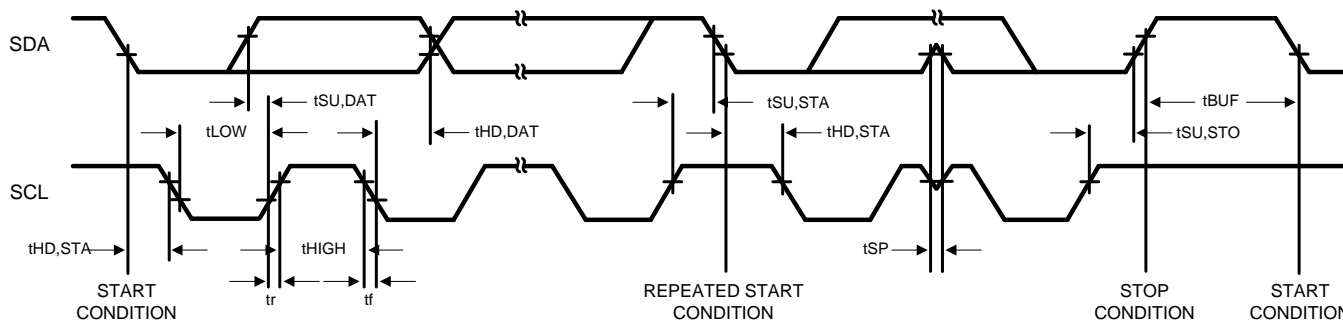

Figure 34. I²C Interface Timing Diagram

Device Functional Modes (continued)

7.4.2 I²C Update Sequence

The TPS65263-1Q1 requires a start condition, a valid I²C address, a register address byte, and a data byte for a single update. After the receipt of each byte, TPS65263-1Q1 device acknowledges by pulling the SDA line low during the high period of a single clock pulse. A valid I²C address selects the TPS65263-1Q1. TPS65263-1Q1 performs an update on the falling edge of the LSB byte.

When the TPS65263-1Q1 is in hardware shutdown (EN1, EN2, and EN3 pin tied to ground) the device cannot be updated through the I²C interface. Conversely, the I²C interface is fully functional during software shutdown (EN1, EN2, and EN3 bit = 0).

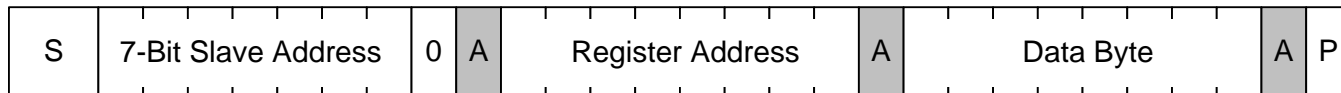
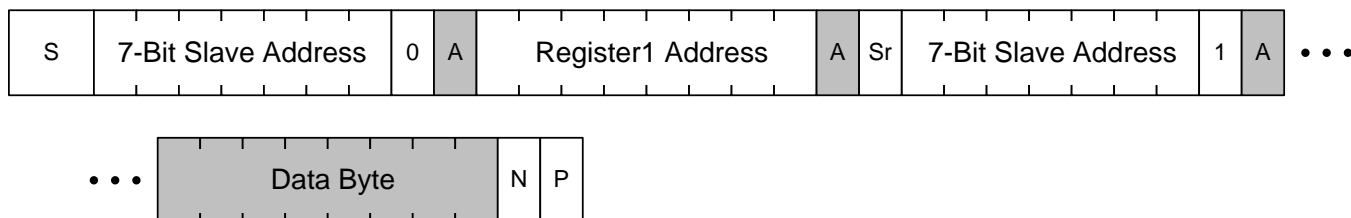

Figure 35. I²C Write Data Format



A: Acknowledge

N: Not Acknowledge

S: Start

P: Stop

Sr: Repeated Start

□ System Host

■ Chip

Figure 36. I²C Read Data Format

7.5 Register Maps

Table 3. Register Addresses

NAME	BITS	ADDRESS
VOUT2_SEL	8	0x01H
VOUT1_COM	8	0X03H
VOUT2_COM	8	0x04H
VOUT3_COM	8	0X05H
SYS_STATUS	8	0x06H

7.5.1 VOUT2_SEL: Vout2 Voltage Selection Register (Address = 0x01H)

Figure 37. VOUT2_SEL: Vout2 Voltage Selection Register

7	6	5	4	3	2	1	0
Vout2_Bit7	Vout2_Bit6	Vout2_Bit5	Vout2_Bit4	Vout2_Bit3	Vout2_Bit2	Vout2_Bit1	Vout2_Bit0

LEGEND: R/W = Read/Write; R = Read only; -n = value after reset

Table 4. VOUT2_SEL: Vout2 Voltage Selection Register Field Descriptions

Bit	Field	Type	Reset	Description
7	Vout2_Bit7	R/W	0	“Go” bit, must set 1 to enable I ² C controlled VID voltages
6	Vout2_Bit6	R/W	0	128 voltage selections with 7-bits control Voltage range: 0.68 to 1.95 V Voltage step resolution: 10 mV 0x00H: Vout2 = 0.68 V; 0x7FH: Vout2 = 1.95 V
5	Vout2_Bit5	R/W	0	
4	Vout2_Bit4	R/W	0	
3	Vout2_Bit3	R/W	0	
2	Vout2_Bit2	R/W	0	
1	Vout2_Bit1	R/W	0	
0	Vout2_Bit0	R/W	0	

7.5.2 VOUT1_COM: Buck1 Command Register (offset = 0x03H)

Figure 38. VOUT1_COM: Buck1 Command Register

7	6	5	4	3	2	1	0
N/A						Mode1	nEN1

LEGEND: R/W = Read/Write; R = Read only; -n = value after reset

Table 5. VOUT1_COM: Buck1 Command Register Field Descriptions

Bit	Field	Type	Reset	Description
7:2	N/A	R/W	000000	Not used
1	Mode1	R/W	0	0: Enable buck 1 PWM operation at light load; 1: Forced buck 1 PSM mode operation
0	nEN1	R/W	0	0: Enable buck1; 1: Disable buck1

7.5.3 VOUT2_COM: Buck2 Command Register (offset = 0x04H)
Figure 39. VOUT2_COM: Buck2 Command Register

7	6	5	4	3	2	1	0
N/A	SR3	SR2	SR1	N/A	N/A	Mode2	nEN2

LEGEND: R/W = Read/Write; R = Read only; -n = value after reset

Table 6. VOUT2_COM: Buck2 Command Register Field Descriptions

Bit	Field	Type	Reset	Description
7	N/A	R/W	0	Not used
6	SR3	R/W	0	Vout2 VID voltage transition Slew Rate control. 000: 10 mV/cycle; 001: 10 mV/2 cycles; 010: 10 mV/4 cycles; 011: 10 mV/8 cycles; 100: 10 mV/16 cycles; 101: 10 mV/32 cycles; 110: 10 mV/64 cycles; 111: 10 mV/128 cycles
5	SR2	R/W	0	
4	SR1	R/W	0	
3	N/A	R/W	0	Not used
2	N/A	R/W	0	Not used
1	Mode2	R/W	0	0: Enable buck 2 PWM operation at light load; 1: Forced buck 2 PSM mode operation
0	nEN2	R/W	0	0: Enable buck2; 1: Disable buck2

7.5.4 VOUT3_COM: Buck3 Command Register (offset = 0x05H)
Figure 40. VOUT3_COM: Buck3 Command Register

7	6	5	4	3	2	1	0
N/A						Mode3	nEN3

LEGEND: R/W = Read/Write; R = Read only; -n = value after reset

Table 7. VOUT3_COM: Buck3 Command Register Field Descriptions

Bit	Field	Type	Reset	Description
7:2	N/A	R/W	000000	Not used
1	Mode3	R/W	0	0: Enable buck 3 PWM operation at light load; 1: Forced buck 3 PSM mode operation
0	nEN3	R/W	0	0: Enable buck3; 1: Disable buck3

7.5.5 SYS_STATUS: System Status Register (offset = 0x06H)
Figure 41. SYS_STATUS: System Status Register

7	6	5	4	3	2	1	0
OTP	OC3	OC2	OC1	OTW	PGOOD3	PGOOD2	PGOOD1

LEGEND: R/W = Read/Write; R = Read only; -n = value after reset

Table 8. SYS_STATUS: System Status Register Field Descriptions

Bit	Field	Type	Reset	Description
7	OTP	R	0	1: Die temperature over 160°C, which triggers over temperature protection; 0: Die overtemperature protection is not triggered.
6	OC3	R	0	1: Buck3 over current limiting and hiccup protection is triggered; 0: Buck3 current not beyond the current limit.
5	OC2	R	0	1: Buck2 overcurrent limiting and hiccup protection is triggered; 0: Buck2 current not beyond the current limit.
4	OC1	R	0	1: Buck1 overcurrent limiting and hiccup protection is triggered; 0: Buck1 current not beyond the current limit.
3	OTW	R	0	1: Die temperature over 125°C; 0: Die temperature below 125°C.
2	PGOOD3	R	0	1: Vout3 in power good monitor's range; 0: Vout3 not in power good monitor's range.
1	PGOOD2	R	0	1: Vout2 in power good monitor's range; 0: Vout2 not in power good monitor's range.
0	PGOOD1	R	0	1: Vout1 in power good monitor's range ; 0: Vout1 not in power good monitor's range.

8 Application and Implementation

NOTE

Information in the following applications sections is not part of the TI component specification, and TI does not warrant its accuracy or completeness. TI's customers are responsible for determining suitability of components for their purposes. Customers should validate and test their design implementation to confirm system functionality.

8.1 Application Information

The device is triple-synchronous step-down dc/dc converter with I²C interface. It is typically used to convert a higher dc voltage to lower dc voltages with continuous available output current of 3 A/2 A/2 A.

8.2 Typical Application

The following design procedure can be used to select component values for the TPS65263-1Q1. This section presents a simplified discussion of the design process.

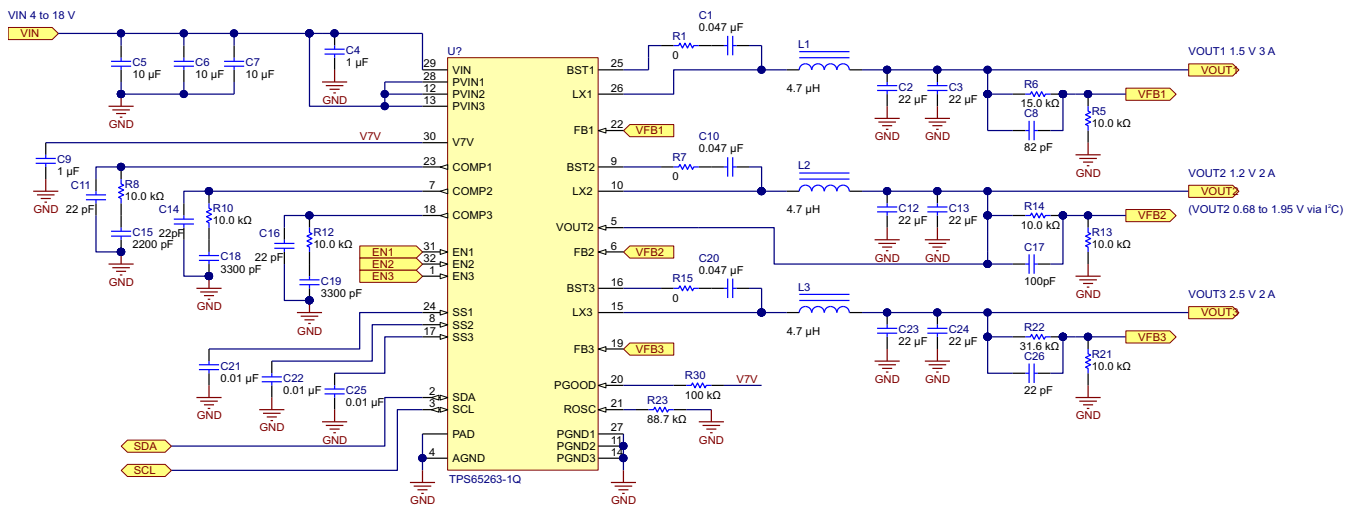

Copyright © 2017, Texas Instruments Incorporated

Figure 42. Typical Application Schematic

8.2.1 Design Requirements

This example details the design of triple-synchronous step-down converter. A few parameters must be known to start the design process. These parameters are typically determined at the system level. For this example, we start with the following known parameters:

Table 9. Design Parameters

PARAMETER	VALUE
Vout1	1.5 V
Iout1	3 A
Vout2	1.2 V
Iout2	2 A
Vout3	2.5 V
Iout3	2 A
Transient response 1-A load step	±5%
Input voltage	12 V normal, 4 to 18 V
Output voltage ripple	±1%
Switching frequency	500 kHz

8.2.2 Detailed Design Procedure

8.2.2.1 Output Inductor Selection

To calculate the value of the output inductor, use [Equation 8](#). LIR is a coefficient that represents the amount of inductor ripple current relative to the maximum output current. The inductor ripple current is filtered by the output capacitor. Therefore, choosing high inductor ripple currents impact the selection of the output capacitor because the output capacitor must have a ripple current rating equal to or greater than the inductor ripple current. In general, the inductor ripple value is at the discretion of the designer; however, LIR is normally from 0.1 to 0.3 for the majority of applications.

$$L = \frac{V_{inmax} - V_{out}}{I_o \times LIR} \times \frac{V_{out}}{V_{inmax} \times f_{sw}} \quad (8)$$

For the output filter inductor, it is important that the RMS current and saturation current ratings not be exceeded. Calculate the RMS and peak inductor current from [Equation 10](#) and [Equation 11](#).

$$I_{ripple} = \frac{V_{inmax} - V_{out}}{L} \times \frac{V_{out}}{V_{inmax} \times f_{sw}} \quad (9)$$

$$I_{Lrms} = \sqrt{I_O^2 + \frac{\left(\frac{V_{out} \times (V_{inmax} - V_{out})}{V_{inmax} \times L \times f_{sw}} \right)^2}{12}} \quad (10)$$

$$I_{Lpeak} = I_{out} + \frac{I_{ripple}}{2} \quad (11)$$

The current flowing through the inductor is the inductor ripple current plus the output current. During power up, faults or transient load conditions, the inductor current can increase above the calculated peak inductor current level calculated above. In transient conditions, the inductor current can increase up to the switch current limit of the device. For this reason, the most conservative approach is to specify an inductor with a saturation current rating equal to or greater than the switch current limit rather than the peak inductor current.

8.2.2.2 Output Capacitor Selection

The three primary considerations for selecting the value of the output capacitor are:

- Output capacitor determines the modulator pole
- Output voltage ripple
- How the regulator responds to a large change in load current

The output capacitance must be selected based on the most stringent of these three criteria.

The desired response to a large change in the load current is the first criterion. The output capacitor needs to supply the load with current when the regulator cannot. This situation would occur if there are desired hold-up times for the regulator where the output capacitor must hold the output voltage above a certain level for a specified amount of time after the input power is removed. The regulator is also temporarily not able to supply sufficient output current if there is a large, fast increase in the current needs of the load such as a transition from no load to full load. The regulator usually needs two or more clock cycles for the control loop to see the change in load current and output voltage and adjust the duty cycle to react to the change. The output capacitor must be sized to supply the extra current to the load until the control loop responds to the load change. The output capacitance must be large enough to supply the difference in current for 2 clock cycles while only allowing a tolerable amount of droop in the output voltage. [Equation 12](#) shows the minimum output capacitance necessary to accomplish this.

$$C_o = \frac{2 \times \Delta I_{out}}{f_{sw} \times \Delta V_{out}}$$

where

- ΔI_{out} is the change in output current
 - f_{sw} is the regulators switching frequency
 - ΔV_{out} is the allowable change in the output voltage
- (12)

Equation 13 calculates the minimum output capacitance needed to meet the output voltage ripple specification.

$$C_o > \frac{1}{8 \times f_{sw}} \times \frac{1}{\frac{V_{oripple}}{I_{oripple}}}$$

where

- f_{sw} is the switching frequency
 - $V_{oripple}$ is the maximum allowable output voltage ripple
 - $I_{oripple}$ is the inductor ripple current
- (13)

Equation 14 calculates the maximum ESR an output capacitor can have to meet the output voltage ripple specification.

$$R_{esr} < \frac{V_{oripple}}{I_{oripple}}$$
(14)

Additional capacitance deratings for aging, temperature, and DC bias should be factored in, which increases this minimum value. Capacitors generally have limits to the amount of ripple current they can handle without failing or producing excess heat. The user must specify an output capacitor that can support the inductor ripple current. Some capacitor data sheets specify the root mean square (RMS) value of the maximum ripple current. Use **Equation 15** to calculate the RMS ripple current the output capacitor needs to support.

$$I_{corms} = \frac{V_{out} \times (V_{inmax} - V_{out})}{\sqrt{12} \times V_{inmax} \times L \times f_{sw}}$$
(15)

8.2.2.3 Input Capacitor Selection

The TPS65263-1Q1 requires a high-quality ceramic, type X5R or X7R, input decoupling capacitor of at least 10 μ F of effective capacitance on the PVIN input voltage pins. In some applications, additional bulk capacitance may also be required for the PVIN input. The effective capacitance includes any DC bias effects. The voltage rating of the input capacitor must be greater than the maximum input voltage. The capacitor must also have a ripple current rating greater than the maximum input current ripple of the TPS65263-1Q1. The input ripple current can be calculated using **Equation 16**.

$$I_{inrms} = I_{out} \times \sqrt{\frac{V_{out}}{V_{inmin}} \times \frac{(V_{inmin} - V_{out})}{V_{inmin}}}$$
(16)

The value of a ceramic capacitor varies significantly over temperature and the amount of DC bias applied to the capacitor. The capacitance variations due to temperature can be minimized by selecting a dielectric material that is stable over temperature. X5R and X7R ceramic dielectrics are usually selected for power regulator capacitors because they have a high capacitance-to-volume ratio and are fairly stable over temperature. The output capacitor must also be selected with the DC bias taken into account. The capacitance value of a capacitor decreases as the DC bias across a capacitor increases. The input capacitance value determines the input ripple voltage of the regulator. Use **Equation 17** to calculate the input voltage ripple.

$$\Delta V_{in} = \frac{I_{outmax} \times 0.25}{C_{in} \times f_{sw}}$$
(17)

8.2.2.4 Loop Compensation

The TPS65263-1Q1 incorporates a peak current mode control scheme. The error amplifier is a transconductance amplifier with a gain of 300 μ S. A typical type II compensation circuit adequately delivers a phase margin between 40° and 90°. C_b adds a high-frequency pole to attenuate high-frequency noise when needed. To calculate the external compensation components, follow these steps.

1. Select switching frequency, f_{sw} , that is appropriate for application depending on L and C sizes, output ripple, EMI, and so forth. Switching frequency between 500 kHz to 1 MHz gives best trade-off between performance and cost. To optimize efficiency, lower switching frequency is desired.
2. Set up crossover frequency, f_c , which is typically between 1/5 and 1/20 of f_{sw} .
3. R_C can be determined by:

$$R_C = \frac{2\pi \times f_c \times V_o \times C_o}{G_{m_EA} \times V_{ref} \times G_{m_PS}}$$

where

- G_{m_EA} is the error amplifier gain (300 μ S).
- G_{m_PS} is the power stage voltage to current conversion gain (7.4 A/V). (18)

4. Calculate C_C by placing a compensation zero at or before the dominant pole $\left(f_p = \frac{1}{C_o \times R_L \times 2\pi} \right)$.
- $$C_C = \frac{R_L \times C_o}{R_C} \tag{19}$$

5. Optional C_b can be used to cancel the zero from the ESR associated with C_o .

$$C_b = \frac{R_{ESR} \times C_o}{R_C} \tag{20}$$

6. Type III compensation can be implemented with the addition of one capacitor, C_1 . This allows for slightly higher loop bandwidths and higher phase margins. If used, calculate C_1 from [Equation 21](#).

$$C_1 = \frac{1}{2\pi \times R_1 \times f_c} \tag{21}$$

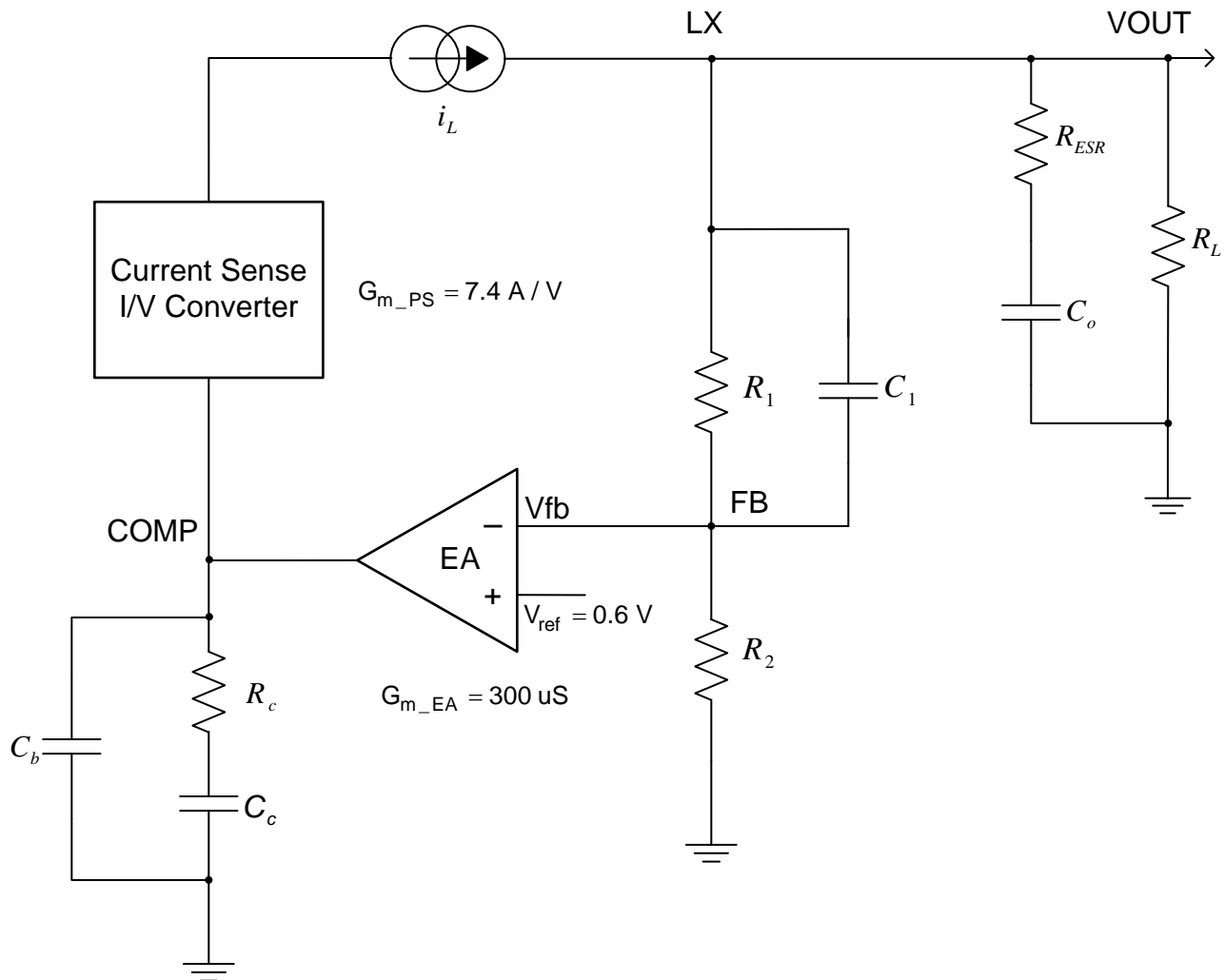
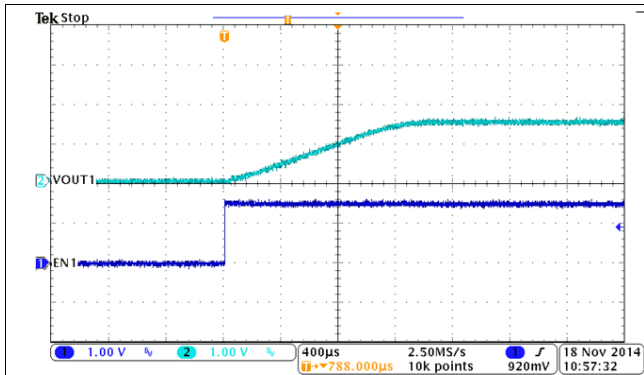

Figure 43. DC/DC Loop Compensation

8.2.3 Application Curves



I_{out} = 3 A

Figure 44. BUCK1, Soft-Start

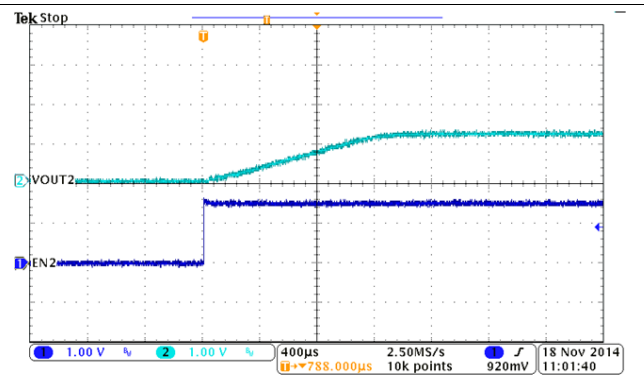

I_{out} = 2 A

Figure 45. BUCK2, Soft-Start

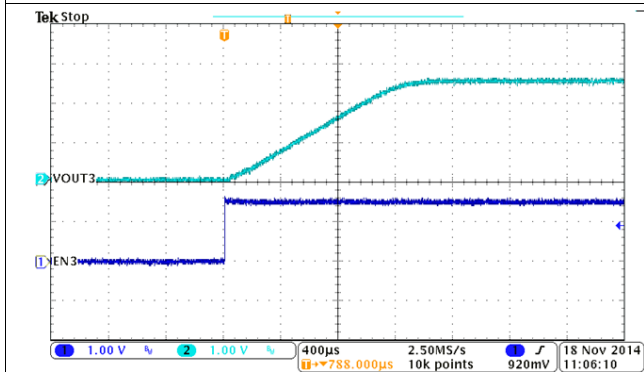

I_{out} = 2 A

Figure 46. BUCK3, Soft-Start

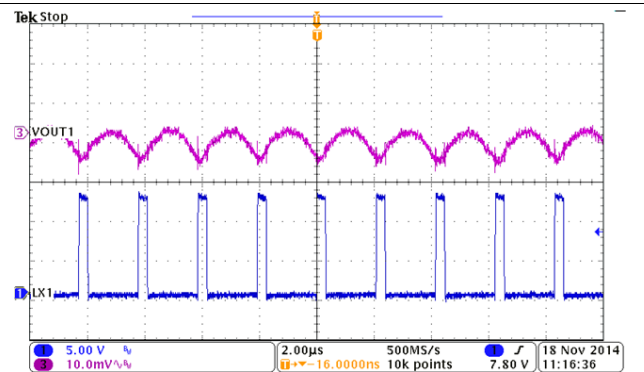

I_{out} = 3 A

Figure 47. BUCK1, Output Voltage Ripple

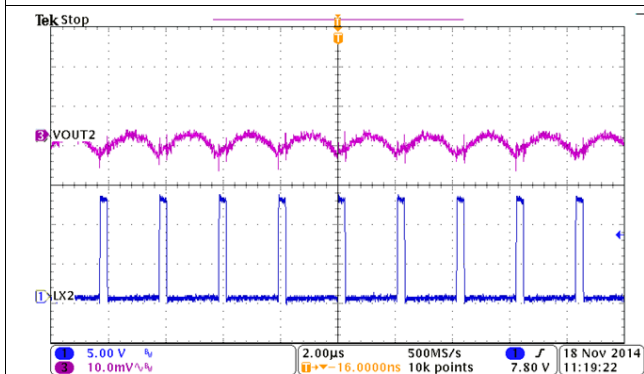

I_{out} = 2 A

Figure 48. BUCK2, Output Voltage Ripple

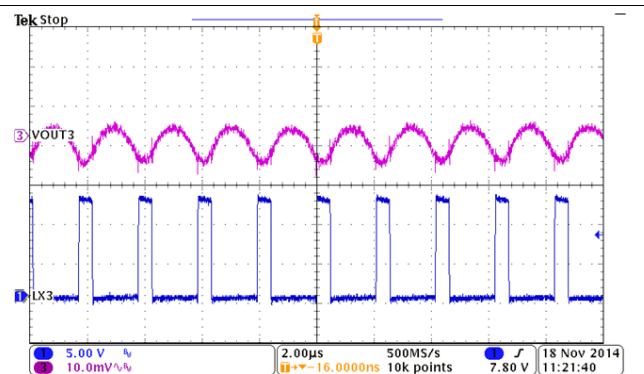

I_{out} = 2 A

Figure 49. BUCK3, Output Voltage Ripple

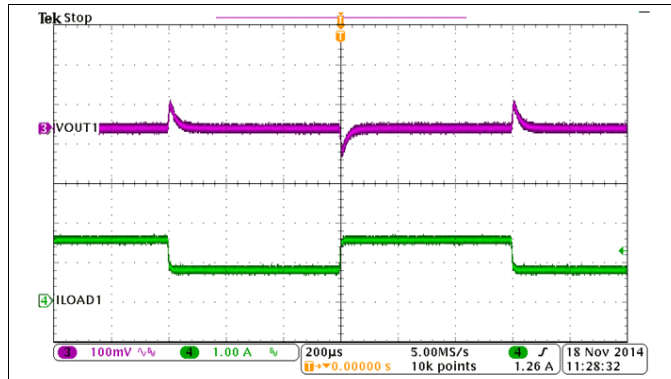

0.75 to 1.5 A SR = 0.25 A/µs

Figure 50. BUCK1, Load Transient

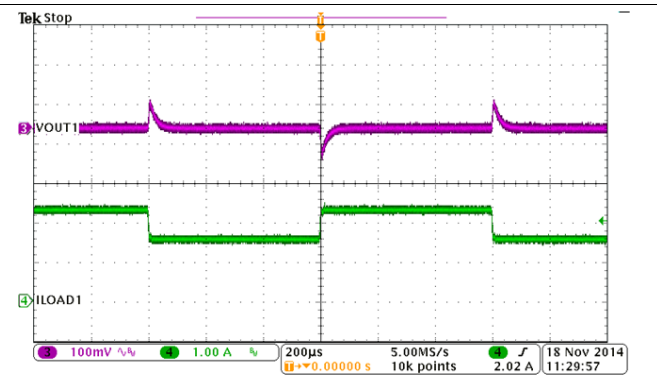

1.5 to 2.25 A SR = 0.25 A/µs

Figure 51. BUCK1, Load Transient

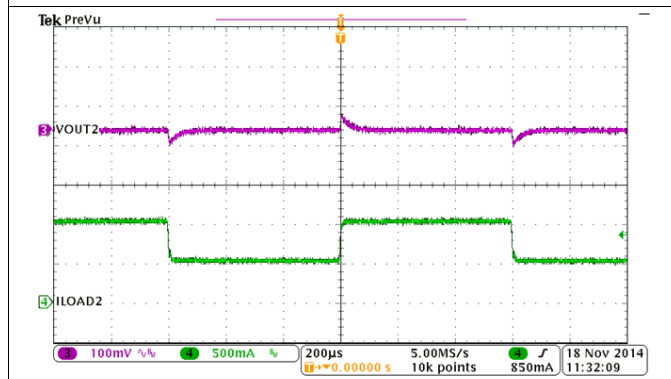

0.5 to 1.0 A SR = 0.25 A/µs

Figure 52. BUCK2, Load Transient

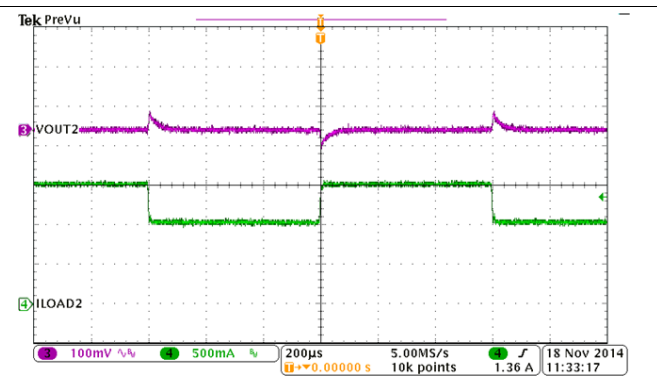

1.0 to 1.5 A SR = 0.25 A/µs

Figure 53. BUCK2, Load Transient

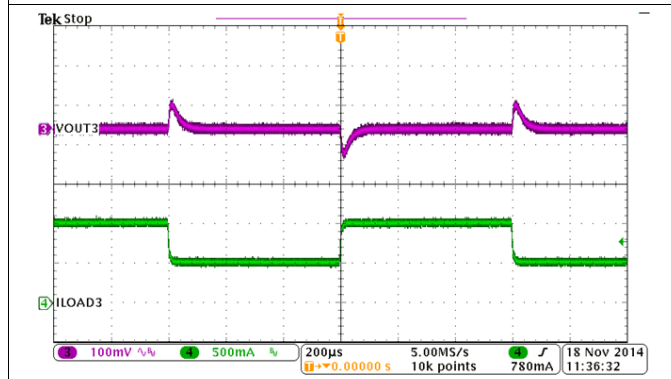

0.5 to 1.0 A SR = 0.25 A/µs

Figure 54. BUCK3, Load Transient

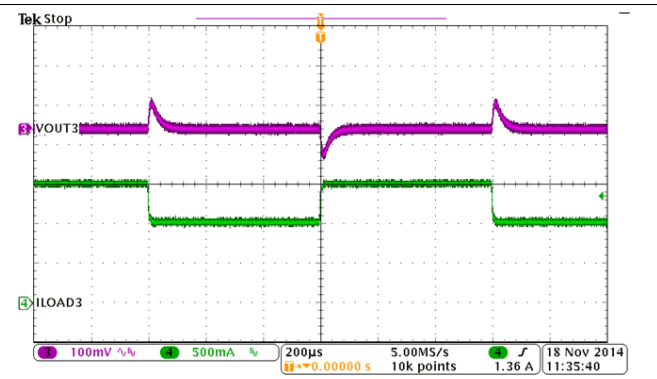

1.0 to 1.5 A SR = 0.25 A/µs

Figure 55. BUCK3, Load Transient

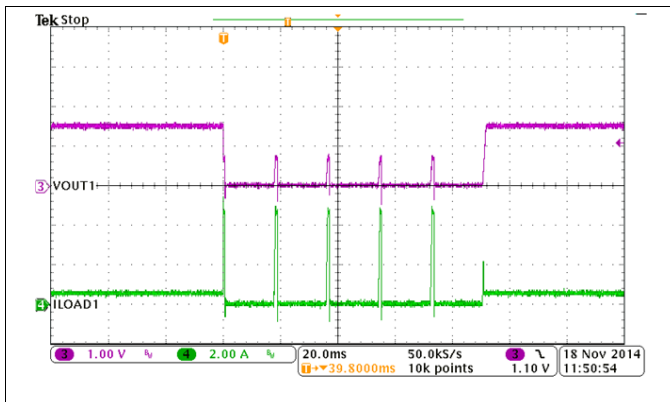

Figure 56. BUCK1, Hiccup and Recovery

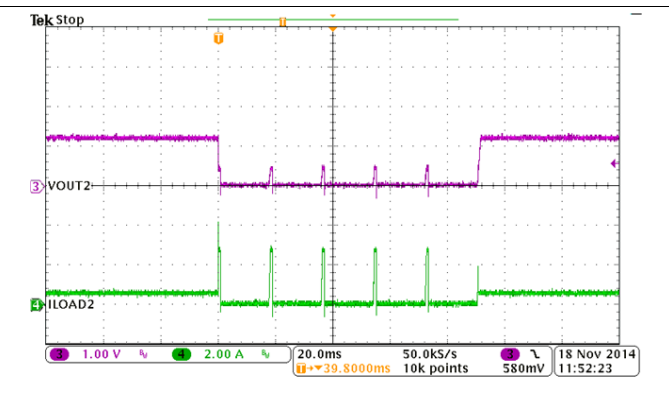

Figure 57. BUCK2, Hiccup and Recovery

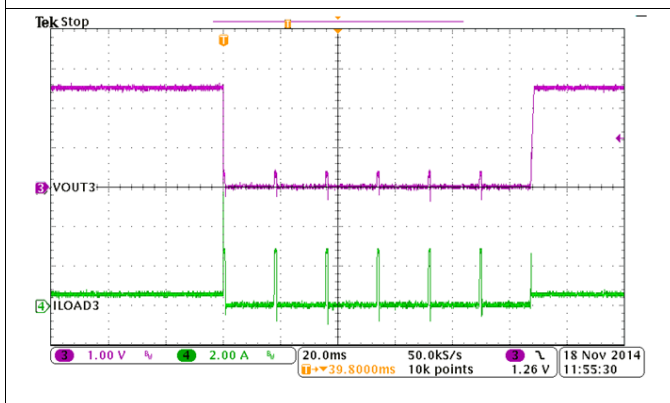

Figure 58. BUCK3, Hiccup and Recovery

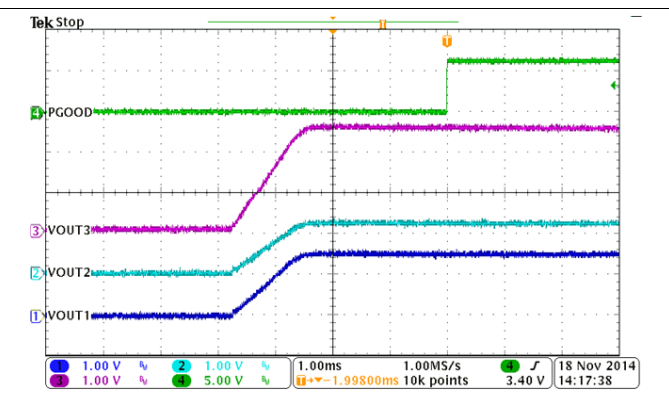

Figure 59. PGOOD

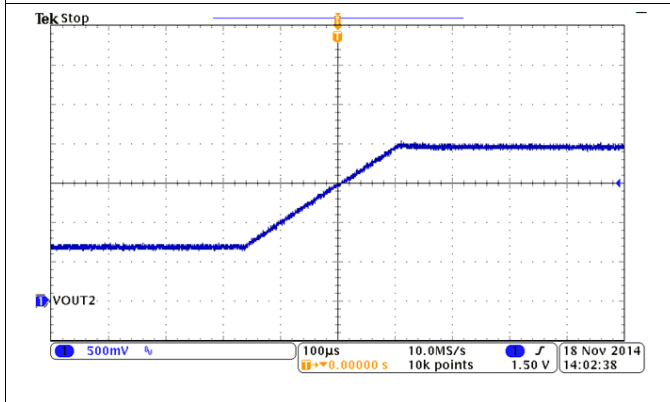

Figure 60. VID2 from 00 to 7F, SR = 10 mV/Cycle

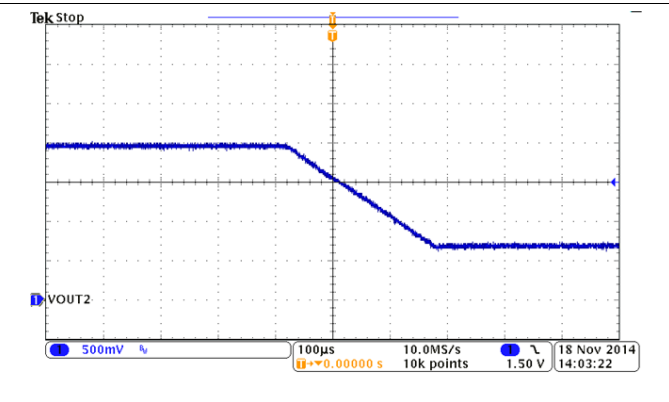

Figure 61. VID2 from 7F to 00, SR = 10 mV/Cycle

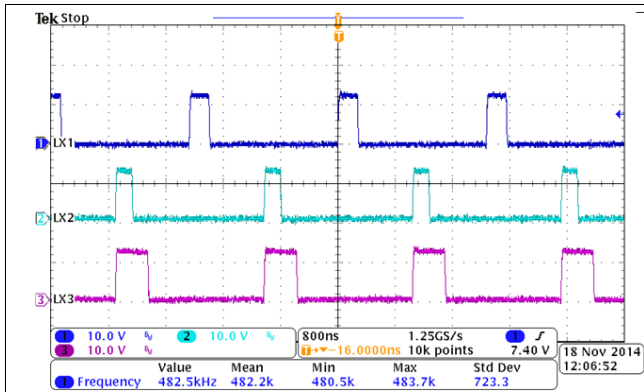

Figure 62. 180° Out-of-Phase

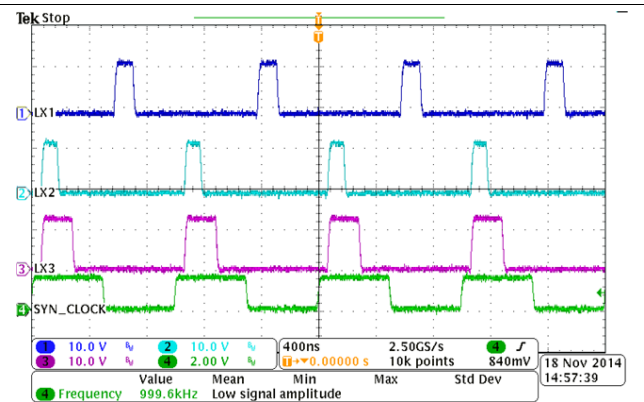

Figure 63. Synchronization With External Clock

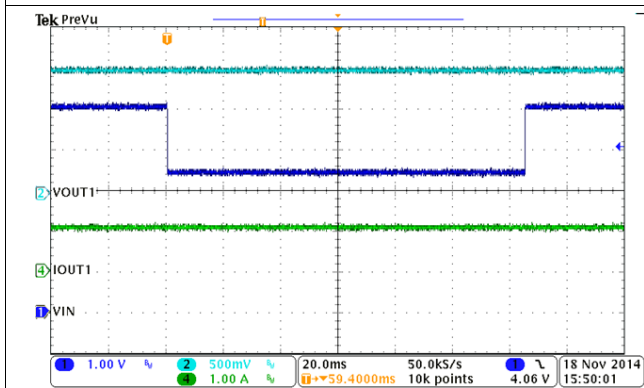
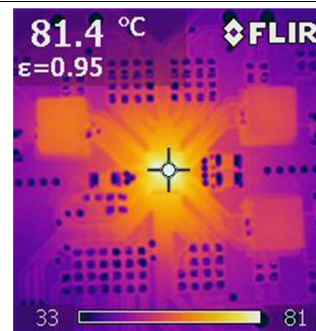

Figure 64. Operation at VIN Drop to 2.5 V



VIN = 12 V, VOUT1 = 1.5 V/3 A, VOUT2 = 1.2 V/2 A,
 VOUT3 = 2.5 V/2 A,
 T_A = 26.8°C EVM condition 4 layers, 75 mm × 75 mm

Figure 65. Thermal Signature of TPS65263-1Q1EVM Operating

9 Power Supply Recommendations

The devices are designed to operate from an input voltage supply range between 4 and 18 V. This input power supply should be well regulated. If the input supply is located more than a few inches from the TPS65263-1Q1 converter, additional bulk capacitance may be required in addition to the ceramic bypass capacitors. An electrolytic capacitor with a value of 47 μ F is a typical choice.

10 Layout

10.1 Layout Guidelines

[Figure 66](#) shows the TPS65263-1Q1 on a 2-layer PCB.

Layout is a critical portion of good power-supply design. See [Figure 66](#) for a PCB layout example. The top contains the main power traces for PVIN, VOUT, and LX. The top layer also has connections for the remaining pins of the TPS65263-1Q1 and a large top-side area filled with ground. The top-layer ground area should be connected to the bottom layer ground using vias at the input bypass capacitor, the output filter capacitor, and directly under the TPS65263-1Q1 device to provide a thermal path from the exposed thermal pad land to ground. The bottom layer acts as ground plane connecting analog ground and power ground.

For operation at full rated load, the top-side ground area together with the bottom-side ground plane must provide adequate heat dissipating area. Several signals paths conduct fast changing currents or voltages that can interact with stray inductance or parasitic capacitance to generate noise or degrade the power supplies' performance. To help eliminate these problems, bypass the PVIN pin to ground with a low-ESR ceramic bypass capacitor with X5R or X7R dielectric. Take care to minimize the loop area formed by the bypass capacitor connections, the PVIN pins, and the ground connections. The VIN pin must also be bypassed to ground using a low-ESR ceramic capacitor with X5R or X7R dielectric.

Because the LX connection is the switching node, the output inductor should be located close to the LX pins, and the area of the PCB conductor minimized to prevent excessive capacitive coupling. The output filter capacitor ground should use the same power ground trace as the PVIN input bypass capacitor. Try to minimize this conductor length while maintaining adequate width. The small signal components should be grounded to the analog ground path.

The FB and COMP pins are sensitive to noise so the resistors and capacitors should be located as close as possible to the IC and routed with minimal lengths of trace. The additional external components can be placed approximately as shown.

10.2 Layout Example

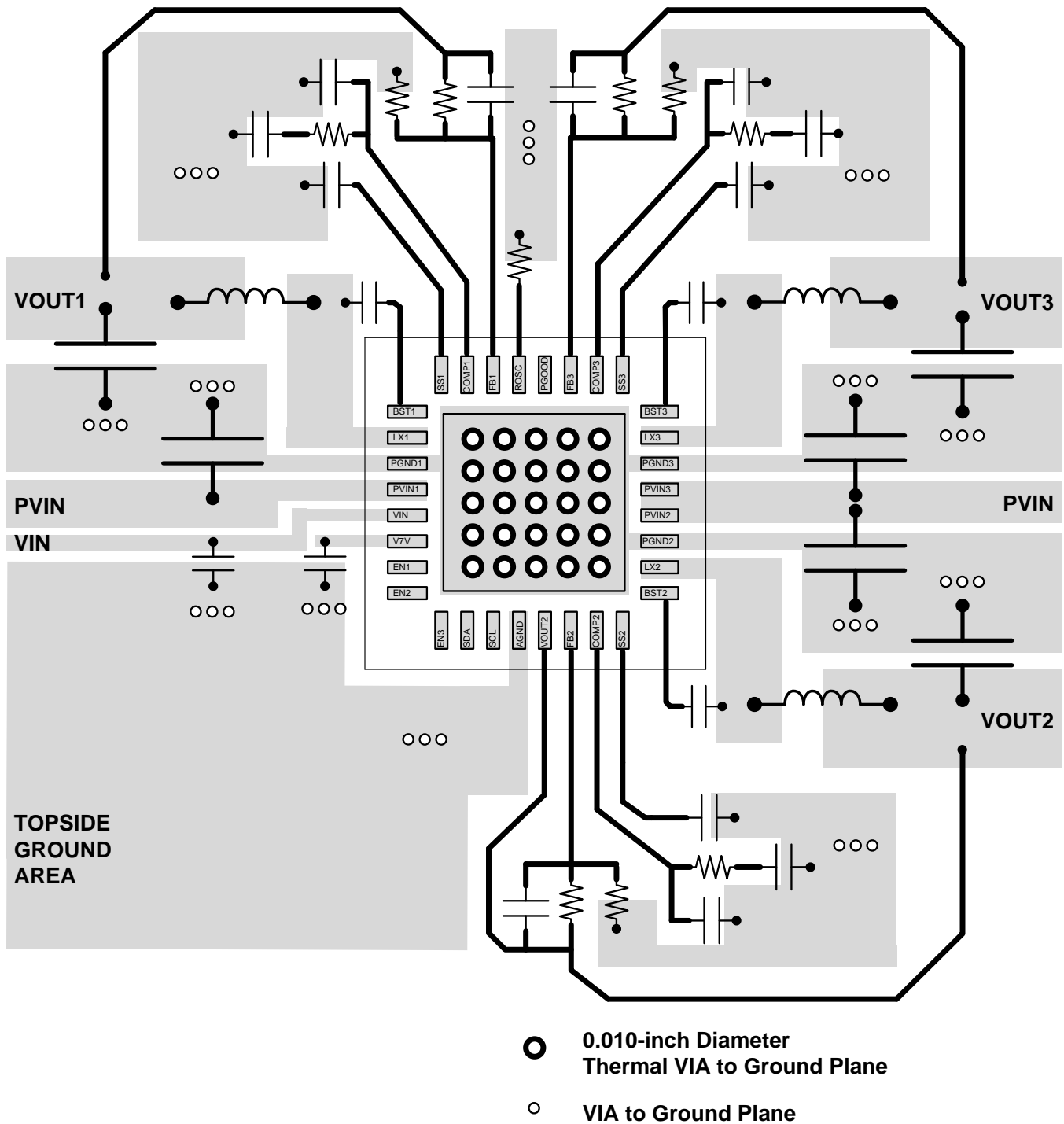

Figure 66. PCB Layout

11 Device and Documentation Support

11.1 Receiving Notification of Documentation Updates

To receive notification of documentation updates, navigate to the device product folder on ti.com. In the upper right corner, click on *Alert me* to register and receive a weekly digest of any product information that has changed. For change details, review the revision history included in any revised document.

11.2 Community Resources

The following links connect to TI community resources. Linked contents are provided "AS IS" by the respective contributors. They do not constitute TI specifications and do not necessarily reflect TI's views; see TI's [Terms of Use](#).

TI E2E™ Online Community *TI's Engineer-to-Engineer (E2E) Community*. Created to foster collaboration among engineers. At e2e.ti.com, you can ask questions, share knowledge, explore ideas and help solve problems with fellow engineers.

Design Support *TI's Design Support* Quickly find helpful E2E forums along with design support tools and contact information for technical support.

11.3 Trademarks

E2E is a trademark of Texas Instruments.
All other trademarks are the property of their respective owners.

11.4 Electrostatic Discharge Caution



These devices have limited built-in ESD protection. The leads should be shorted together or the device placed in conductive foam during storage or handling to prevent electrostatic damage to the MOS gates.

11.5 Glossary

[SLYZ022](#) — *TI Glossary*.

This glossary lists and explains terms, acronyms, and definitions.

12 Mechanical, Packaging, and Orderable Information

The following pages include mechanical, packaging, and orderable information. This information is the most current data available for the designated devices. This data is subject to change without notice and revision of this document. For browser-based versions of this data sheet, refer to the left-hand navigation.

PACKAGING INFORMATION

Orderable Device	Status (1)	Package Type	Package Drawing	Pins	Package Qty	Eco Plan (2)	Lead/Ball Finish (6)	MSL Peak Temp (3)	Op Temp (°C)	Device Marking (4/5)	Samples
TPS65263-1QRHBRQ1	PREVIEW	VQFN	RHB	32	3000	Green (RoHS & no Sb/Br)	CU NIPDAU	Level-2-260C-1 YEAR	-40 to 125	TPS 263-1Q	
TPS65263-1QRHBTQ1	PREVIEW	VQFN	RHB	32	250	Green (RoHS & no Sb/Br)	CU NIPDAU	Level-2-260C-1 YEAR	-40 to 125	TPS 263-1Q	

(1) The marketing status values are defined as follows:

ACTIVE: Product device recommended for new designs.

LIFEBUY: TI has announced that the device will be discontinued, and a lifetime-buy period is in effect.

NRND: Not recommended for new designs. Device is in production to support existing customers, but TI does not recommend using this part in a new design.

PREVIEW: Device has been announced but is not in production. Samples may or may not be available.

OBsolete: TI has discontinued the production of the device.

(2) Eco Plan - The planned eco-friendly classification: Pb-Free (RoHS), Pb-Free (RoHS Exempt), or Green (RoHS & no Sb/Br) - please check <http://www.ti.com/productcontent> for the latest availability information and additional product content details.

TBD: The Pb-Free/Green conversion plan has not been defined.

Pb-Free (RoHS): TI's terms "Lead-Free" or "Pb-Free" mean semiconductor products that are compatible with the current RoHS requirements for all 6 substances, including the requirement that lead not exceed 0.1% by weight in homogeneous materials. Where designed to be soldered at high temperatures, TI Pb-Free products are suitable for use in specified lead-free processes.

Pb-Free (RoHS Exempt): This component has a RoHS exemption for either 1) lead-based flip-chip solder bumps used between the die and package, or 2) lead-based die adhesive used between the die and leadframe. The component is otherwise considered Pb-Free (RoHS compatible) as defined above.

Green (RoHS & no Sb/Br): TI defines "Green" to mean Pb-Free (RoHS compatible), and free of Bromine (Br) and Antimony (Sb) based flame retardants (Br or Sb do not exceed 0.1% by weight in homogeneous material)

(3) MSL, Peak Temp. - The Moisture Sensitivity Level rating according to the JEDEC industry standard classifications, and peak solder temperature.

(4) There may be additional marking, which relates to the logo, the lot trace code information, or the environmental category on the device.

(5) Multiple Device Markings will be inside parentheses. Only one Device Marking contained in parentheses and separated by a "~" will appear on a device. If a line is indented then it is a continuation of the previous line and the two combined represent the entire Device Marking for that device.

(6) Lead/Ball Finish - Orderable Devices may have multiple material finish options. Finish options are separated by a vertical ruled line. Lead/Ball Finish values may wrap to two lines if the finish value exceeds the maximum column width.

Important Information and Disclaimer: The information provided on this page represents TI's knowledge and belief as of the date that it is provided. TI bases its knowledge and belief on information provided by third parties, and makes no representation or warranty as to the accuracy of such information. Efforts are underway to better integrate information from third parties. TI has taken and continues to take reasonable steps to provide representative and accurate information but may not have conducted destructive testing or chemical analysis on incoming materials and chemicals. TI and TI suppliers consider certain information to be proprietary, and thus CAS numbers and other limited information may not be available for release.

In no event shall TI's liability arising out of such information exceed the total purchase price of the TI part(s) at issue in this document sold by TI to Customer on an annual basis.

OTHER QUALIFIED VERSIONS OF TPS65263-1Q1 :

- Automotive: [TPS65263-Q1](#)

NOTE: Qualified Version Definitions:

- Automotive - Q100 devices qualified for high-reliability automotive applications targeting zero defects

MECHANICAL DATA

RHB (S-PVQFN-N32)

PLASTIC QUAD FLATPACK NO-LEAD

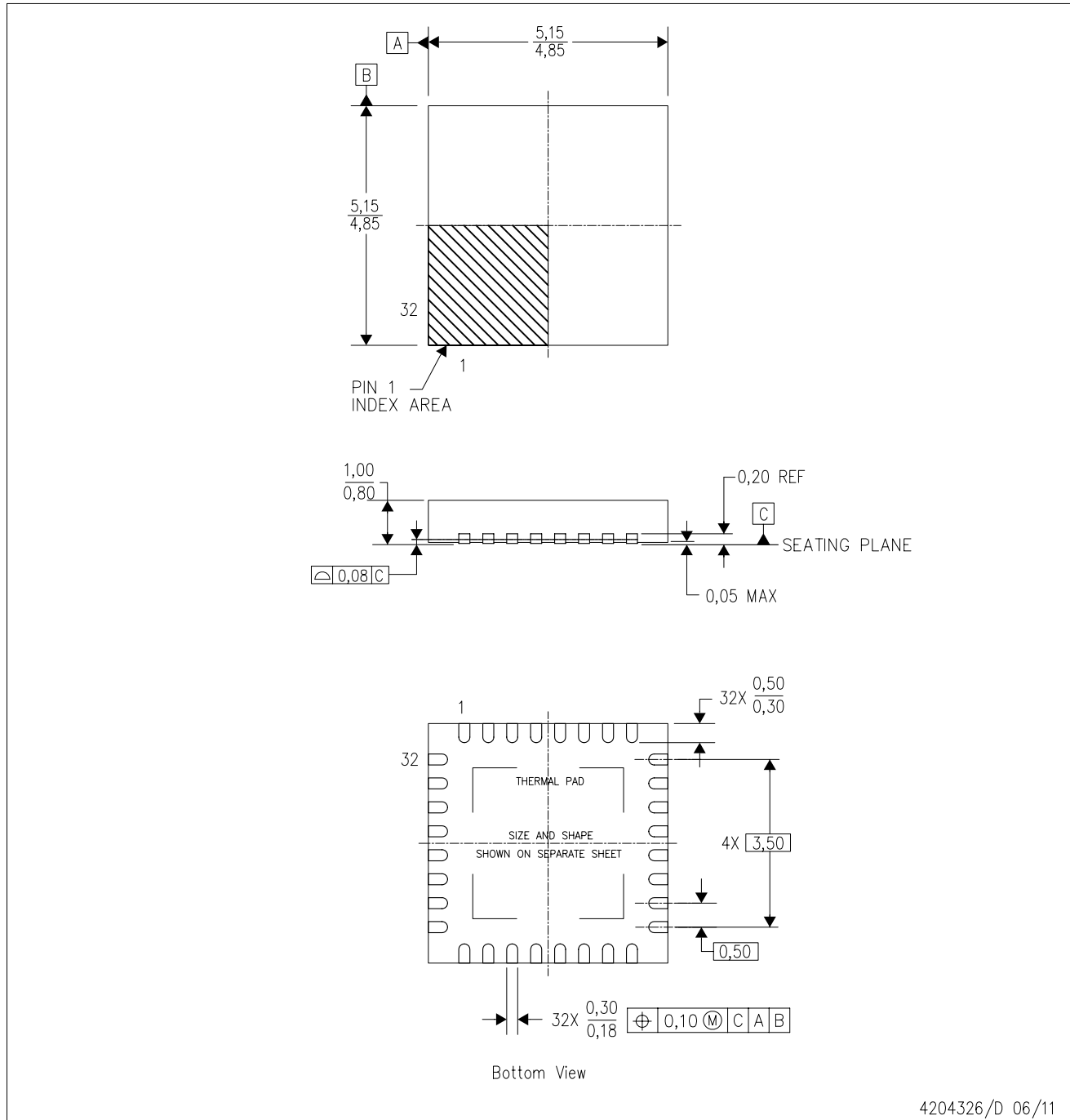

- NOTES:
- All linear dimensions are in millimeters. Dimensioning and tolerancing per ASME Y14.5M-1994.
 - This drawing is subject to change without notice.
 - QFN (Quad Flatpack No-Lead) Package configuration.
 - The package thermal pad must be soldered to the board for thermal and mechanical performance.
 - See the additional figure in the Product Data Sheet for details regarding the exposed thermal pad features and dimensions.
 - Falls within JEDEC MO-220.

THERMAL INFORMATION

This package incorporates an exposed thermal pad that is designed to be attached directly to an external heatsink. The thermal pad must be soldered directly to the printed circuit board (PCB). After soldering, the PCB can be used as a heatsink. In addition, through the use of thermal vias, the thermal pad can be attached directly to the appropriate copper plane shown in the electrical schematic for the device, or alternatively, can be attached to a special heatsink structure designed into the PCB. This design optimizes the heat transfer from the integrated circuit (IC).

For information on the Quad Flatpack No-Lead (QFN) package and its advantages, refer to Application Report, QFN/SON PCB Attachment, Texas Instruments Literature No. SLUA271. This document is available at www.ti.com.

The exposed thermal pad dimensions for this package are shown in the following illustration.

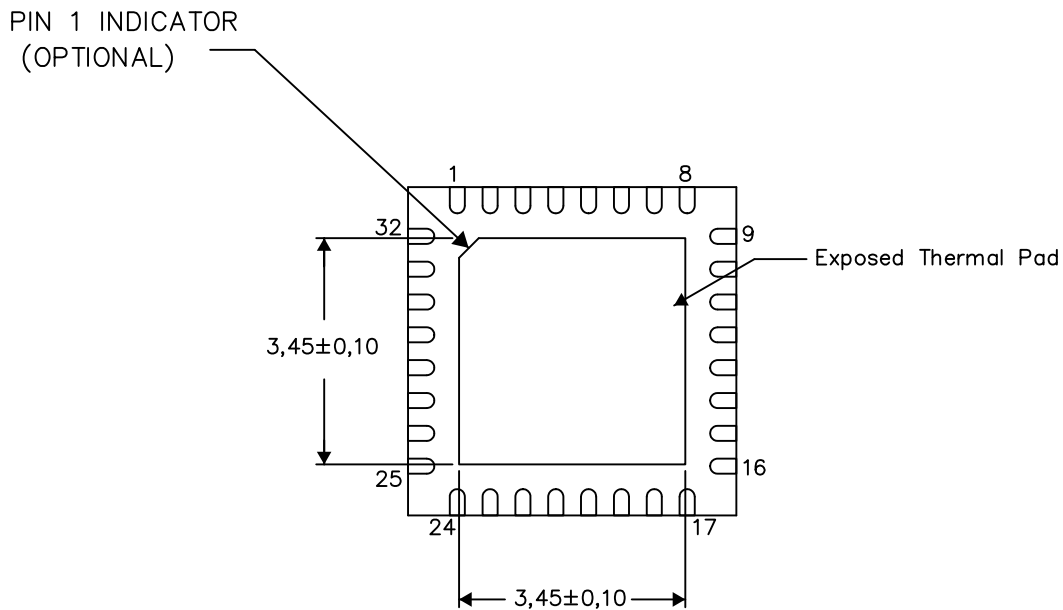

Bottom View

Exposed Thermal Pad Dimensions

4206356-2/AC 05/15

NOTE: A. All linear dimensions are in millimeters

RHB (S-PVQFN-N32)

PLASTIC QUAD FLATPACK NO-LEAD

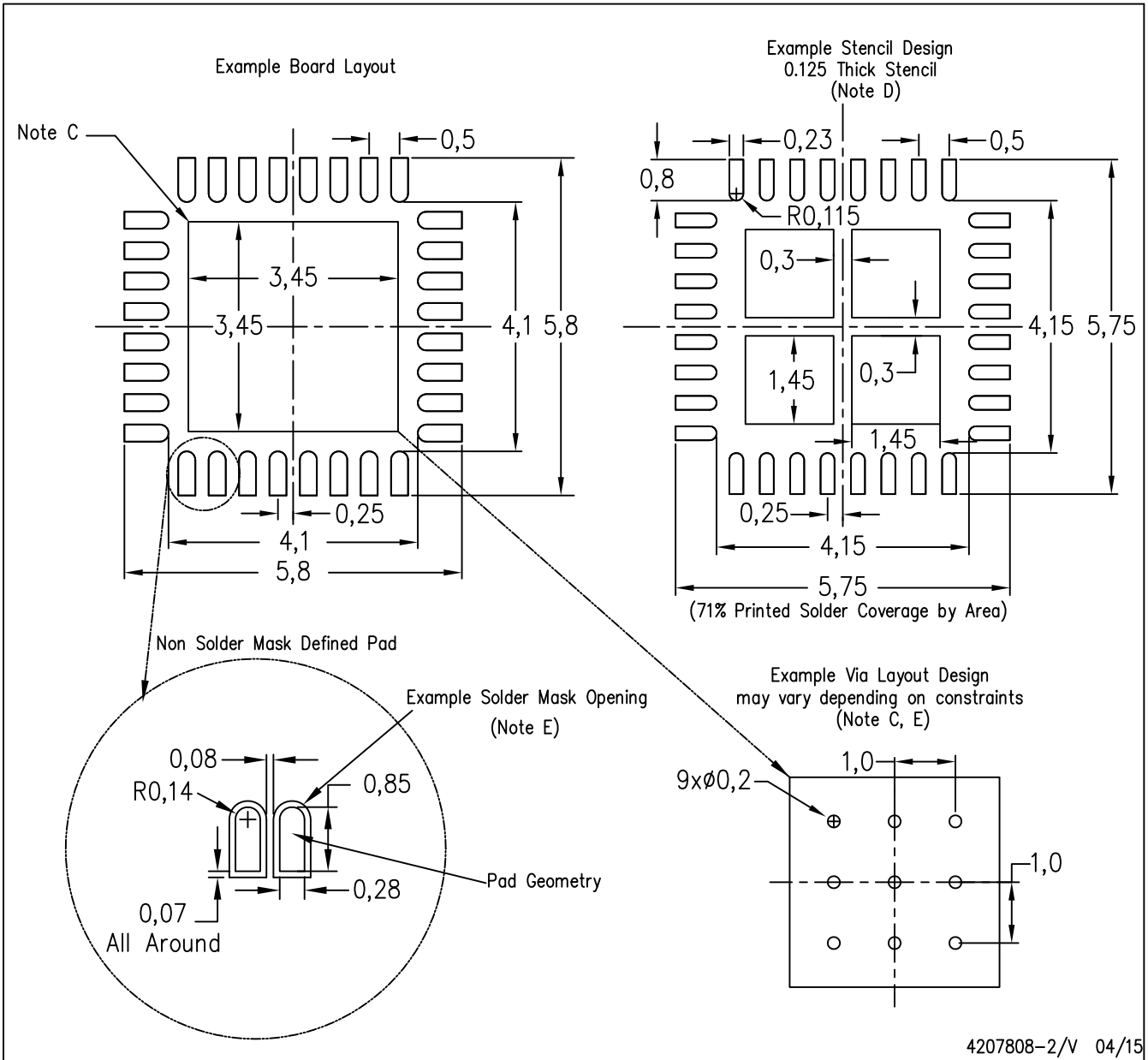

4207808-2/V 04/15

- NOTES:
- All linear dimensions are in millimeters.
 - This drawing is subject to change without notice.
 - This package is designed to be soldered to a thermal pad on the board. Refer to Application Note, Quad Flat-Pack Packages, Texas Instruments Literature No. SLUA271, and also the Product Data Sheets for specific thermal information, via requirements, and recommended board layout. These documents are available at www.ti.com <<http://www.ti.com>>.
 - Laser cutting apertures with trapezoidal walls and also rounding corners will offer better paste release. Customers should contact their board assembly site for stencil design recommendations. Refer to IPC 7525 for stencil design considerations.
 - Customers should contact their board fabrication site for recommended solder mask tolerances and via tenting recommendations for any larger diameter vias placed in the thermal pad.

IMPORTANT NOTICE FOR TI DESIGN INFORMATION AND RESOURCES

Texas Instruments Incorporated ("TI") technical, application or other design advice, services or information, including, but not limited to, reference designs and materials relating to evaluation modules, (collectively, "TI Resources") are intended to assist designers who are developing applications that incorporate TI products; by downloading, accessing or using any particular TI Resource in any way, you (individually or, if you are acting on behalf of a company, your company) agree to use it solely for this purpose and subject to the terms of this Notice.

TI's provision of TI Resources does not expand or otherwise alter TI's applicable published warranties or warranty disclaimers for TI products, and no additional obligations or liabilities arise from TI providing such TI Resources. TI reserves the right to make corrections, enhancements, improvements and other changes to its TI Resources.

You understand and agree that you remain responsible for using your independent analysis, evaluation and judgment in designing your applications and that you have full and exclusive responsibility to assure the safety of your applications and compliance of your applications (and of all TI products used in or for your applications) with all applicable regulations, laws and other applicable requirements. You represent that, with respect to your applications, you have all the necessary expertise to create and implement safeguards that (1) anticipate dangerous consequences of failures, (2) monitor failures and their consequences, and (3) lessen the likelihood of failures that might cause harm and take appropriate actions. You agree that prior to using or distributing any applications that include TI products, you will thoroughly test such applications and the functionality of such TI products as used in such applications. TI has not conducted any testing other than that specifically described in the published documentation for a particular TI Resource.

You are authorized to use, copy and modify any individual TI Resource only in connection with the development of applications that include the TI product(s) identified in such TI Resource. NO OTHER LICENSE, EXPRESS OR IMPLIED, BY ESTOPPEL OR OTHERWISE TO ANY OTHER TI INTELLECTUAL PROPERTY RIGHT, AND NO LICENSE TO ANY TECHNOLOGY OR INTELLECTUAL PROPERTY RIGHT OF TI OR ANY THIRD PARTY IS GRANTED HEREIN, including but not limited to any patent right, copyright, mask work right, or other intellectual property right relating to any combination, machine, or process in which TI products or services are used. Information regarding or referencing third-party products or services does not constitute a license to use such products or services, or a warranty or endorsement thereof. Use of TI Resources may require a license from a third party under the patents or other intellectual property of the third party, or a license from TI under the patents or other intellectual property of TI.

TI RESOURCES ARE PROVIDED "AS IS" AND WITH ALL FAULTS. TI DISCLAIMS ALL OTHER WARRANTIES OR REPRESENTATIONS, EXPRESS OR IMPLIED, REGARDING TI RESOURCES OR USE THEREOF, INCLUDING BUT NOT LIMITED TO ACCURACY OR COMPLETENESS, TITLE, ANY EPIDEMIC FAILURE WARRANTY AND ANY IMPLIED WARRANTIES OF MERCHANTABILITY, FITNESS FOR A PARTICULAR PURPOSE, AND NON-INFRINGEMENT OF ANY THIRD PARTY INTELLECTUAL PROPERTY RIGHTS.

TI SHALL NOT BE LIABLE FOR AND SHALL NOT DEFEND OR INDEMNIFY YOU AGAINST ANY CLAIM, INCLUDING BUT NOT LIMITED TO ANY INFRINGEMENT CLAIM THAT RELATES TO OR IS BASED ON ANY COMBINATION OF PRODUCTS EVEN IF DESCRIBED IN TI RESOURCES OR OTHERWISE. IN NO EVENT SHALL TI BE LIABLE FOR ANY ACTUAL, DIRECT, SPECIAL, COLLATERAL, INDIRECT, PUNITIVE, INCIDENTAL, CONSEQUENTIAL OR EXEMPLARY DAMAGES IN CONNECTION WITH OR ARISING OUT OF TI RESOURCES OR USE THEREOF, AND REGARDLESS OF WHETHER TI HAS BEEN ADVISED OF THE POSSIBILITY OF SUCH DAMAGES.

You agree to fully indemnify TI and its representatives against any damages, costs, losses, and/or liabilities arising out of your non-compliance with the terms and provisions of this Notice.

This Notice applies to TI Resources. Additional terms apply to the use and purchase of certain types of materials, TI products and services. These include; without limitation, TI's standard terms for semiconductor products (<http://www.ti.com/sc/docs/stdterms.htm>), [evaluation modules](#), and [samples](http://www.ti.com/sc/docs/sampterm.htm) (<http://www.ti.com/sc/docs/sampterm.htm>).

Mailing Address: Texas Instruments, Post Office Box 655303, Dallas, Texas 75265
Copyright © 2017, Texas Instruments Incorporated