

DC-DC INVERTER

FEATURES

- Adjustable Output Voltage Down to -15 V
- 2.7-V to 5.5-V Input Voltage Range
- Up to 360-mA Output Current
- 1000-mA Typical Switch Current Limit
- Up to 84% Efficiency
- Typical 1.4-MHz Fixed-Frequency PWM Operation
- Thermal Shutdown
- Typical -19 V Output Overvoltage Protection
- $1.5\text{-}\mu\text{A}$ Shutdown Current
- Small 3-mm x 3-mm SON-10 Package (DRC)

APPLICATIONS

- Generic Negative Voltage Supply
- Small-to-Medium Size OLED Displays
- PDAs, Pocket PCs, Smartphones
- Bias Supply

DESCRIPTION

The TPS63700 is an inverting dc-dc converter generating a negative output voltage down to -15 V with output currents up to 360-mA, depending on input-voltage to output-voltage ratio. With a total efficiency up to 84%, the device is ideal for portable battery-powered equipment. The input voltage range of 2.7-V to 5.5-V allows the TPS63700 to be directly powered from a Li-ion battery, from 3-cell NiMH/NiCd, from a 3.3-V or 5-V supply rail. The TPS63700 comes in a small 3-mm x 3-mm SON-10 package. Furthermore, the high switching frequency of typically 1.4 MHz allows the use of small external components. This, and the small package make a small power supply solution possible.

The inverter operates with a fixed-frequency PWM control topology. The device has an internal current limit, overvoltage protection, and a thermal shutdown for highest reliability under fault conditions.

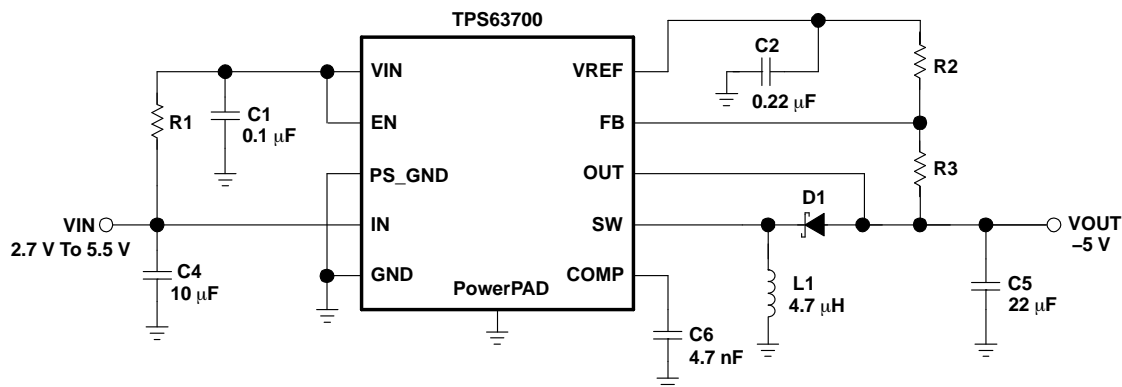

Please be aware that an important notice concerning availability, standard warranty, and use in critical applications of Texas Instruments semiconductor products and disclaimers thereto appears at the end of this data sheet.

PowerPAD is a trademark of Texas Instruments.



This integrated circuit can be damaged by ESD. Texas Instruments recommends that all integrated circuits be handled with appropriate precautions. Failure to observe proper handling and installation procedures can cause damage.

ESD damage can range from subtle performance degradation to complete device failure. Precision integrated circuits may be more susceptible to damage because very small parametric changes could cause the device not to meet its published specifications.

ORDERING INFORMATION⁽¹⁾

T _A	SWITCH CURRENT LIMIT	PACKAGE TYPE	SYMBOL	PART NUMBER ⁽²⁾
-40°C to 85°C	1000 mA	SON-10	NUB	TPS63700DRC

- (1) For the most current package and ordering information, see the Package Option Addendum at the end of this document, or see the TI Web site at www.ti.com.
- (2) The DRC package is available taped and reeled. Add an R suffix to the device type (i.e., TPS63700DRCR) to order quantities of 3000 devices per reel. Add a T suffix to the device type (i.e., TPS63700DRCT) to order quantities of 250 devices per reel.

ABSOLUTE MAXIMUM RATINGS

over operating free-air temperature range unless otherwise noted⁽¹⁾

	TPS63700
Input voltage range at V _{IN} ⁽²⁾	-0.3 V to +6.0 V
Input voltage range at I _N ⁽²⁾	V _{IN}
Minimum voltage at V _{OUT} ⁽²⁾	-18 V
Voltage at EN, FB, COMP, PS ⁽²⁾	-0.3 V to V _{IN} + 0.3 V
Differential voltage between OUT to V _{IN} ⁽²⁾	24 V
Operating virtual junction temperature, T _J	-40°C to 150°C
Storage temperature range, T _{STG}	-65°C to 150°C

- (1) Stresses beyond those listed under "absolute maximum ratings" may cause permanent damage to the device. These are stress ratings only, and functional operation of the device at these or any other conditions beyond those indicated under "recommended operating conditions" is not implied. Exposure to absolute-maximum-rated conditions for extended periods may affect device reliability.
- (2) All voltage values are with respect to network ground terminal, unless otherwise noted.

DISSIPATION RATINGS TABLE⁽¹⁾

PACKAGE	T _A ≤ 25°C POWER RATING	DERATING FACTOR ABOVE T _A = 25°C	T _A = 70°C POWER RATING	T _A = 85°C POWER RATING
DRC	2053 mW	21 mW/°C	1130 mW	821 mW

- (1) The thermal resistance junction to ambient of the 10-pin DRC is $\theta_{JA} = 48.7$ °C/W. Exceeding the maximum junction temperature forces the device into thermal shutdown.

RECOMMENDED OPERATING CONDITIONS

	MIN	NOM	MAX	UNIT
Input voltage range, V _I	2.7		5.5	V
Operating free-air temperature range, T _A	-40		85	°C
Operating virtual junction temperature range, T _J	-40		125	°C

ELECTRICAL CHARACTERISTICS

–40°C to 85°C, over recommended input voltage range, typical at an ambient temperature of 25°C (unless otherwise noted)

PARAMETER		TEST CONDITIONS	MIN	TYP	MAX	UNIT
DC-DC STAGE						
V_{OUT}	Adjustable output voltage range		–15		–2	V
V_{IN}	Input voltage range	PIN V_{IN} , IN	2.7		5.5	V
V_{REF}	Reference voltage	$I_{REF} = 10 \mu A$	1.2	1.213	1.225	V
I_{FB}	Negative feedback input bias current	$V_{FBN} = 0.1 V_{REF}$		2		nA
V_{FB}	Negative feedback regulation voltage	$V_{IN} = 2.7 V$ to 5.5 V	–0.024	0	0.024	V
V_{OUT}	DC output accuracy	PWM mode, device switching,		± 3		%
V_{OVP}	Output overvoltage protection			–19		V
$R_{DS(ON)}$	Inverter switch on-resistance	$V_{IN} = 3.6 V$		440	600	m Ω
		$V_{IN} = 5 V$		370	500	
I_{LIM}	Inverter switch current limit	$2.7 V < V_{IN} < 5.5 V$	860	1000	1140	mA
D_{MAX}	Maximum duty cycle inverting converter			87.5%		
D_{MIN}	Minimum duty cycle inverting converter			12.5%		
CONTROL STAGE						
f_S	Oscillator frequency		1250	1380	1500	kHz
V_{EN}	High level input voltage		1.4			V
V_{EN}	Low level input voltage				0.4	V
I_{EN}	Input current	EN = V_{IN} or GND		0.01	0.1	μA
$I_{(Q)}$	Quiescent current	VIN	$V_{IN} = 3.6 V$, $I_{OUT} = 0$, EN = V_{IN} , no switching $V_{OUT} = -5 V$	330	400	μA
		IN		640	750	μA
I_{SD}	Shutdown supply current	EN = GND		0.2	1.5	μA
V_{UVLO}	Undervoltage lockout threshold		2.1	2.35	2.7	V
	Thermal shutdown			150		$^{\circ}C$
	Thermal shutdown hysteresis	Junction temperature decreasing		5		$^{\circ}C$

PIN ASSIGNMENTS

**DRC PACKAGE PowerPAD™
(TOP VIEW)**

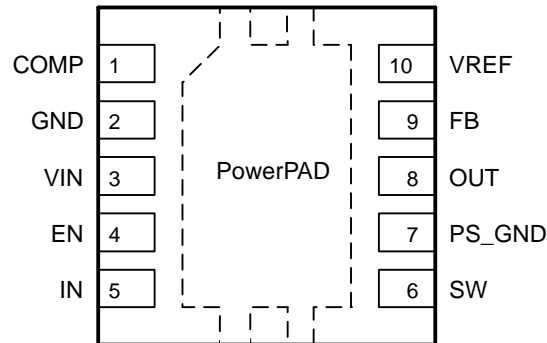

Terminal Functions

TERMINAL NAME	NO.	I/O	DESCRIPTION
COMP	1	I/O	Compensation pin for control, connect a 4.7nF capacitor between this pin and GND
EN	4	I	Enable pin (EN=GND: disabled; EN=VIN: enabled)
FB	9	I	Feedback pin for the voltage divider
GND	2		Ground pin
IN	5	I	supply voltage for the power switch
OUT	8	I	Output voltage sense input
PS_GND	7	I	Connect to GND for control logic
SW	6	O	Inverter switch output
VIN	3	I	supply voltage for control logic, connect a RC filter of 10R and 100nF
VREF	10	O	Reference voltage output. Connect a 220-nF capacitor to ground. Connect the lower resistor of the negative output voltage divider to this pin.

FUNCTIONAL BLOCK DIAGRAM

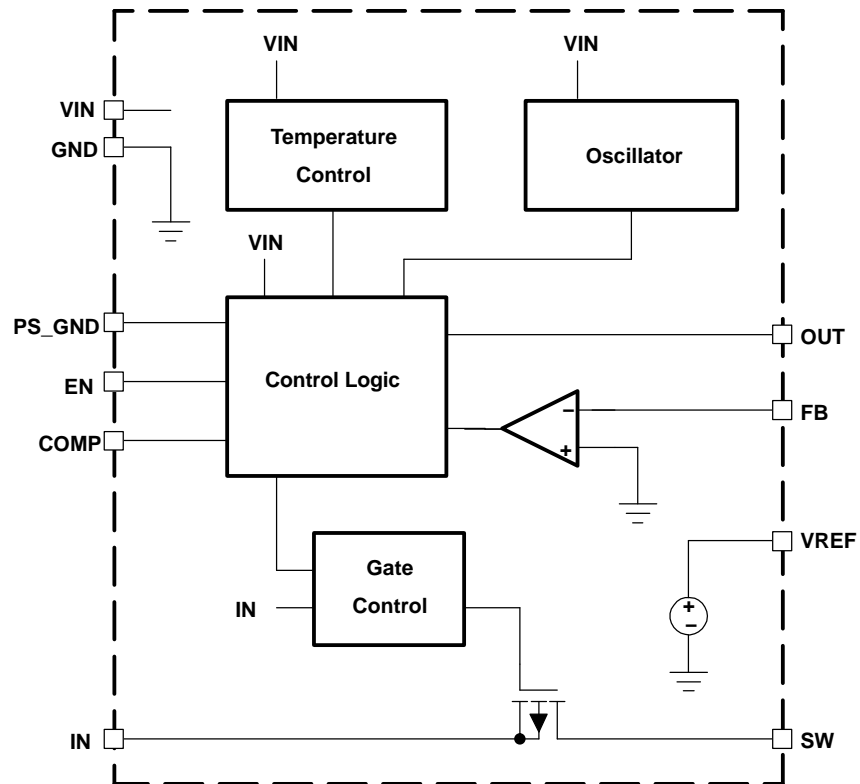

TYPICAL CHARACTERISTICS

PARAMETER MEASUREMENT INFORMATION

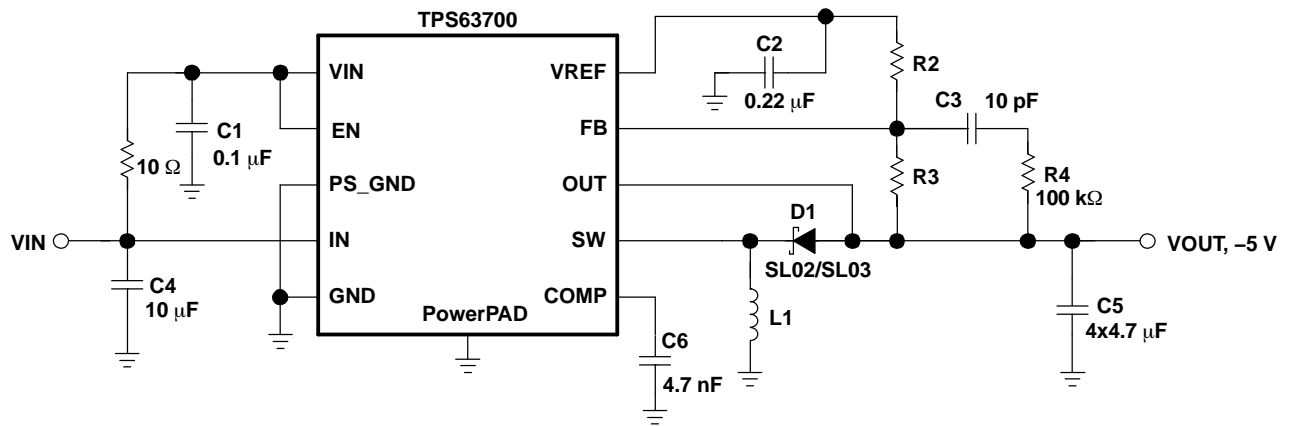

List of Components

REFERENCE	DESCRIPTION
C1, C2, C3, C4,	X7R/X5R ceramic
C5	4 x 4.7 μF X7R/X5R ceramic
D1	SL03/SL02 Vishay
L1	-5V: TDK VLF4012 4R7, TDK SLF6025-4R7, Coilcraft LPS4018-472,
	-12V: Sumida CDRH5D18 10 μH

Table of Graphs

GRAPH	DESCRIPTION
Figure 1	Maximum output current versus input voltage, $V_{OUT} = -5\text{ V}, -12\text{ V}, -15\text{ V}$
Figure 2	Efficiency versus output current, $V_{OUT} = -5\text{ V}$
Figure 3	Efficiency versus output current, $V_{OUT} = -12\text{ V}$
Figure 4	Efficiency versus output current, $V_{OUT} = -15\text{ V}$
Figure 5	Efficiency versus input voltage, $V_{OUT} = -5\text{ V}$
Figure 6	Efficiency versus input voltage, $V_{OUT} = -12\text{ V}$
Figure 7	Output voltage versus output current, $V_{OUT} = -5\text{ V}$
Figure 8	Output voltage versus output current, $V_{OUT} = -12\text{ V}$
Figure 9	Output voltage in discontinuous conduction mode, $V_{IN} = 3.6\text{ V}, V_{OUT} = -5\text{ V}$
Figure 10	Output voltage in continuous conduction mode, $V_{IN} = 3.6\text{ V}, V_{OUT} = -5\text{ V}$
Figure 11	Load transient response, $V_{IN} = 3.6\text{ V}, V_{OUT} = -5\text{ V}, 45\text{ to }150\text{ mA}$
Figure 12	Line transient response, $V_{IN} = 3.6\text{ V to }4.2\text{ V}, V_{OUT} = -5\text{ V}$
Figure 13	Start-up after enable, $V_I = 3.6\text{ V}, V_{OUT} = -5\text{ V}$

PERFORMANCE GRAPHS

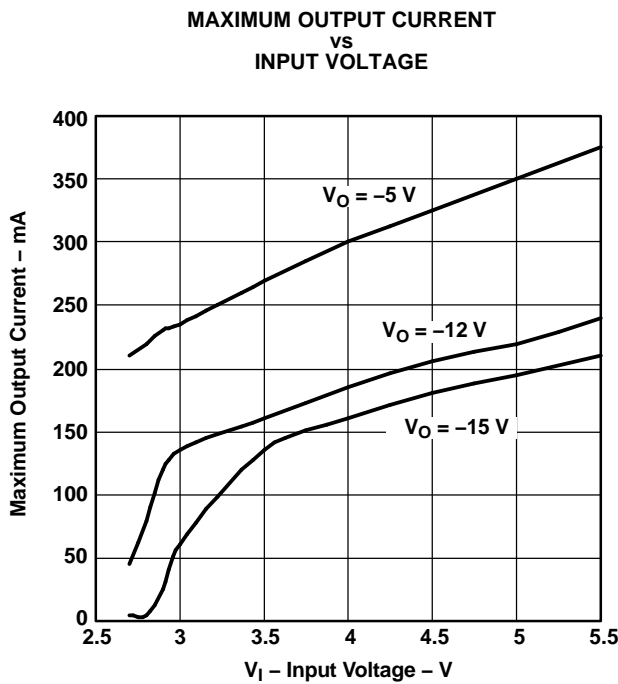

Figure 1.

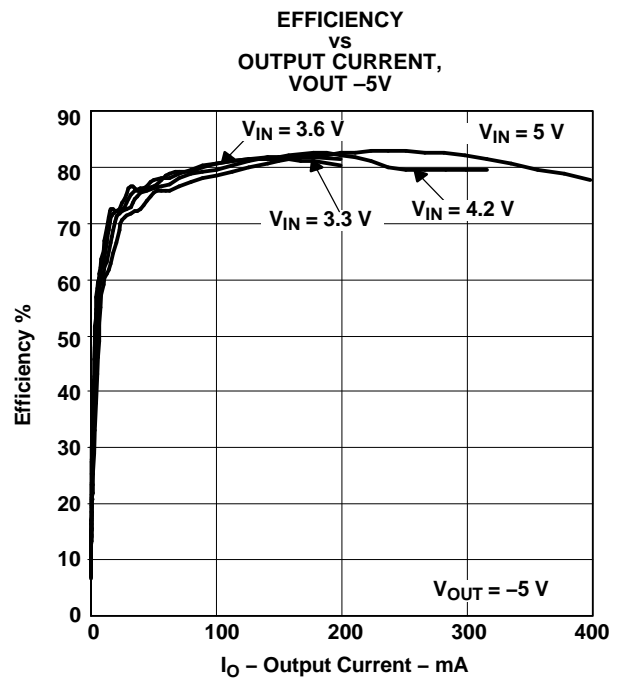
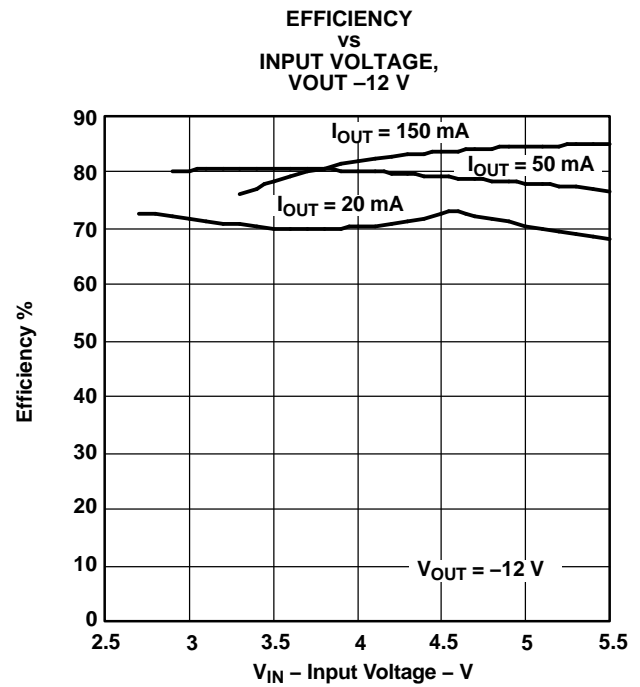
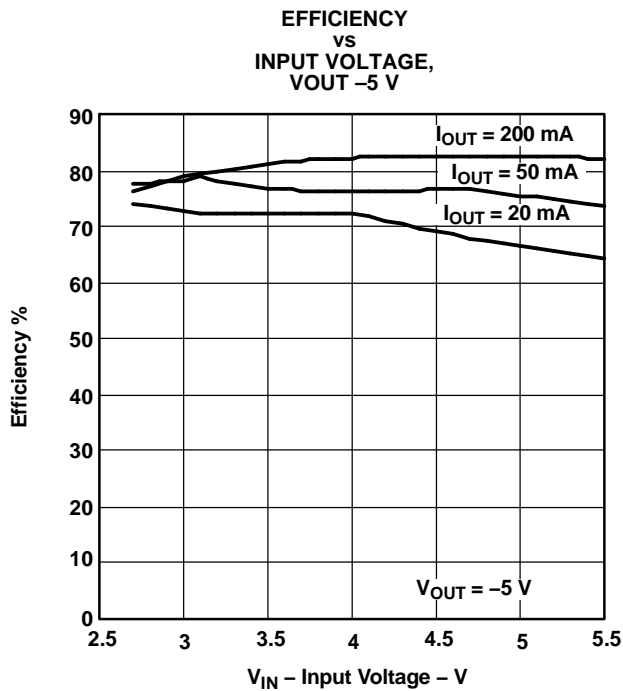
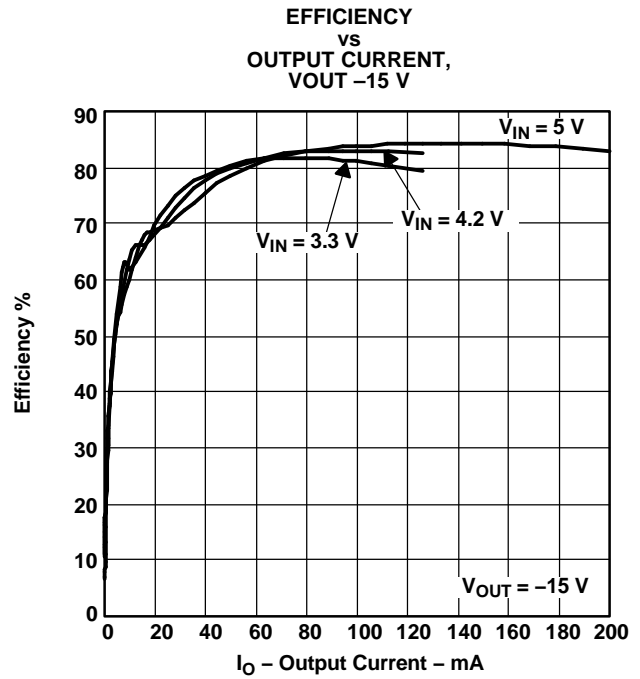
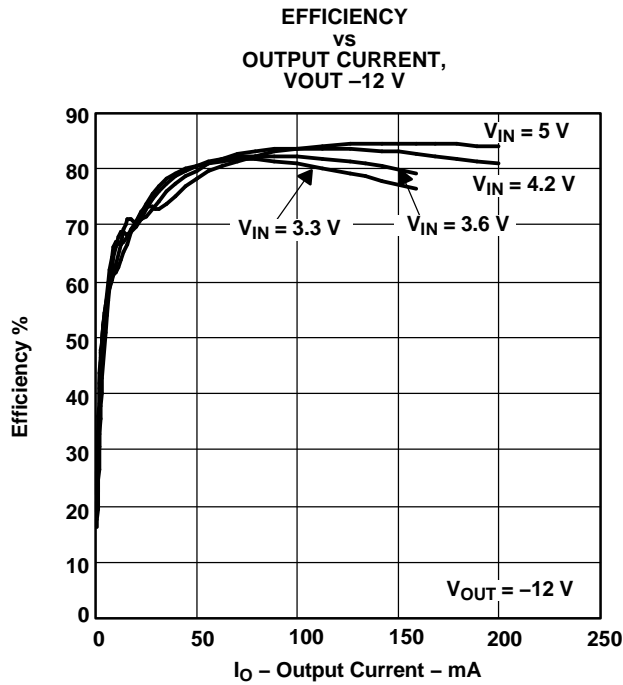
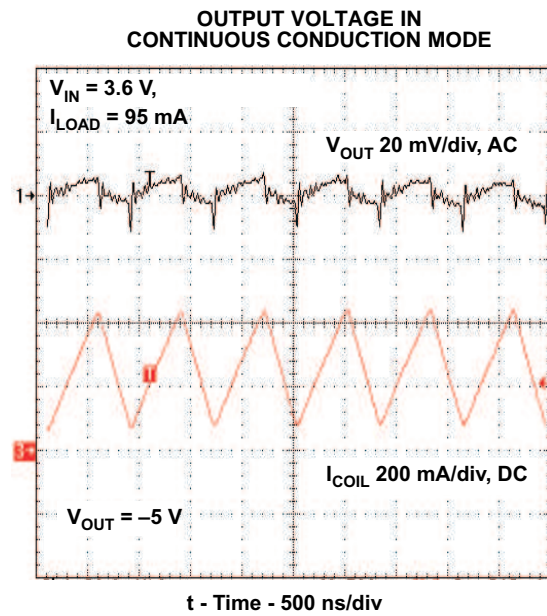
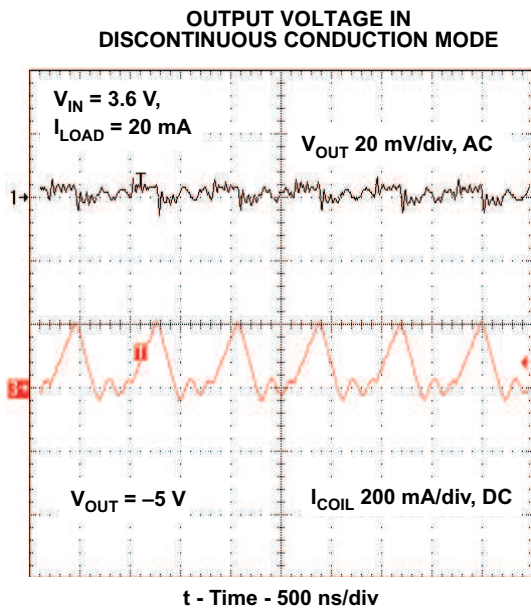
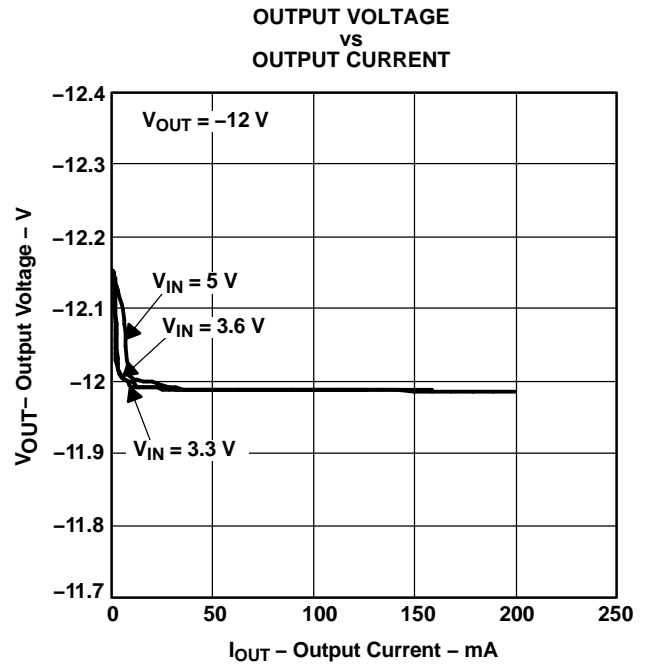
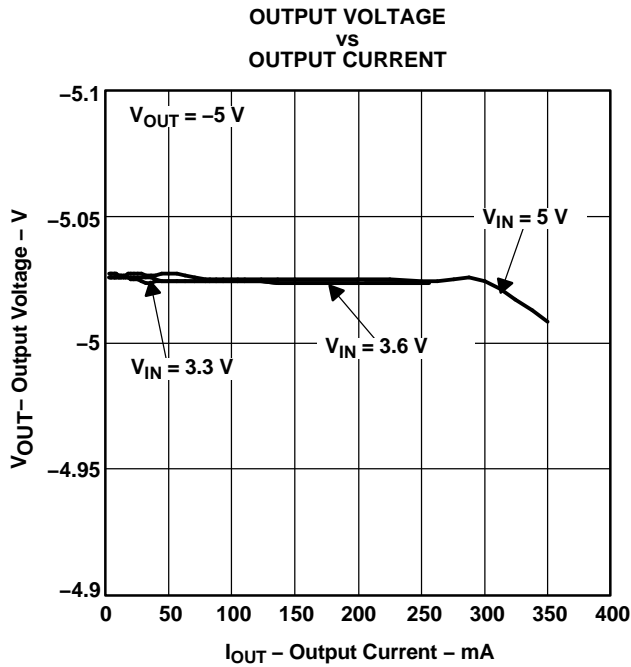

Figure 2.

PERFORMANCE GRAPHS (continued)



PERFORMANCE GRAPHS (continued)



PERFORMANCE GRAPHS (continued)

LOAD TRANSIENT RESPONSE,
-5 V, 45 TO 150 mA

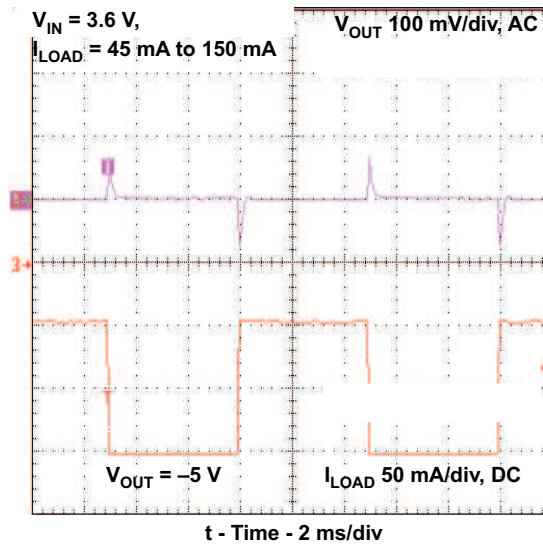

Figure 11.

LINE TRANSIENT RESPONSE, -5 V

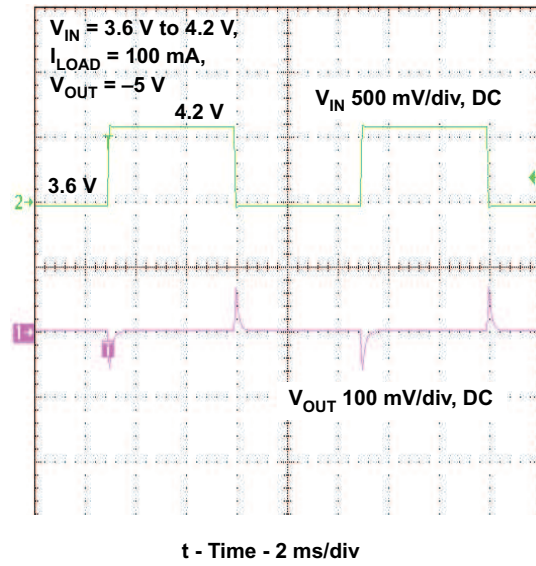

Figure 12.

START-UP AFTER ENABLE, -5 V

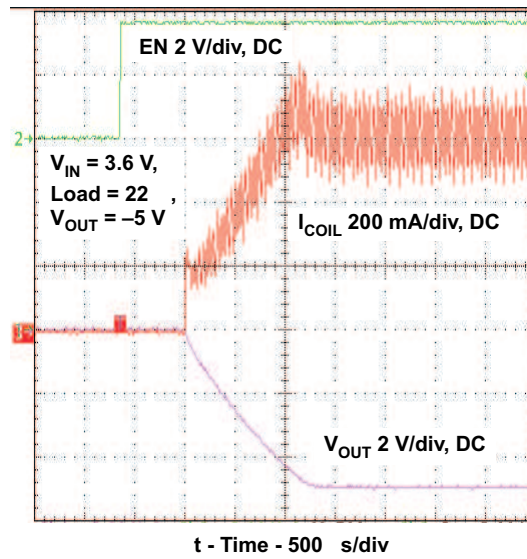

Figure 13.

DETAILED DESCRIPTION

The TPS63700 is a dc-dc converter for negative output voltages using buck-boost topology. It operates with an input voltage range of 2.7 V to 5.5 V and generates a negative output voltage down to –15 V. The output is controlled by a fixed-frequency, pulse-width-modulated (PWM) regulator. In normal operation mode, the converter operates at continuous conduction mode (CCM). At light loads it can enter discontinuous conduction mode (DCM).

Power Conversion

The converter operates in a fixed-frequency, pulse-width-modulated control scheme. So, the on-time of the switches varies depending on input-to-output voltage ratio and the load. During this on-time, the inductor connected to the converter is charged with current. In the remaining time, the time period set by the fixed operating frequency, the inductor discharges into the output capacitor via the rectifier diode. Usually, at higher loads the inductor current is continuous. During light load, the inductor current of this converter can become discontinuous. In this case, the control circuit of the controller output automatically takes care of these changing conditions to always operate with an optimum control setup.

Control

The controller circuit of the converter is based on a fixed-frequency, multiple-feedforward controller topology. Input voltage, output voltage, and voltage drop across the switch are monitored and forwarded to the regulator. Changes in the operating conditions of the converter directly affect the duty cycle.

The error amplifier compares the voltage on FB pin with GND to generate an accurate and stable output voltage. The error amplifier is internally compensated. At light loads, the converter operates in discontinuous conduction mode (DCM).

If the load will be further decreased, the energy transmitted to the output capacitor can't be absorbed by the load and would lead to an increase of the output voltage. In this case, the converter limits the output voltage increase by skipping switch pulses.

Enable

Applying GND signal at the EN pin disables the converter, where all internal circuitry is turned off. The device now just consumes low shutdown current flowing into the VIN pin. The output load of the converter is also disconnected from the battery as described in the following paragraph. Pulling the EN pin to V_{IN} enables the converter. Internal circuitry, necessary to operate the converter, is then turned on.

Load Disconnect

The device supports complete load disconnection when the converter is disabled. The converter turns off the internal PMOS switch, thus no DC current path remains between load and input voltage source.

Soft Start

The converter has a soft-start function. When the converter is enabled, the implemented switch current limit ramps up slowly to its nominal value. Soft start is implemented to limit the input current during start-up to avoid high peak currents at the battery which could interfere with other systems connected to the same battery.

Without soft start, uncontrolled input peak currents flow to charge up the output capacitors and to supply the load during start-up. This would cause significant voltage drops across the series resistance of the battery and its connections.

Output Overvoltage Protection

The converter has an implemented output overvoltage protection. The output voltage is limited to –19 V in case the feedback connection from the output to the FB pin is open.

DETAILED DESCRIPTION (continued)**Undervoltage Lockout**

An undervoltage lockout prevents the device from starting up and operating if the supply voltage at VIN is lower than the programmed threshold shown in the electrical characteristics table. The device automatically shuts down the converter when the supply voltage at VIN falls below this threshold. Nevertheless, parts of the control circuits remain active, which is different than device shutdown using EN inputs. The undervoltage lockout function is implemented to prevent device malfunction.

Overtemperature Shutdown

The device automatically shuts down if the implemented internal temperature detector detects a chip temperature above the programmed threshold shown in the electrical characteristics table. It starts operating again when the chip temperature decreases. A built-in temperature hysteresis avoids undefined operation caused by ringing from overtemperature shutdown.

APPLICATION INFORMATION

Design Procedure

The TPS63700 dc-dc converter is intended for systems typically powered by a single-cell Li-ion or Li-polymer battery with a terminal voltage between 2.7 V up to 4.2 V. Due to the recommended input voltage going up to 5.5 V, the device is also suitable for 3-cell alkaline, NiCd, or NiMH batteries, as well as regulated supply voltages of 3.3 V or 5 V.

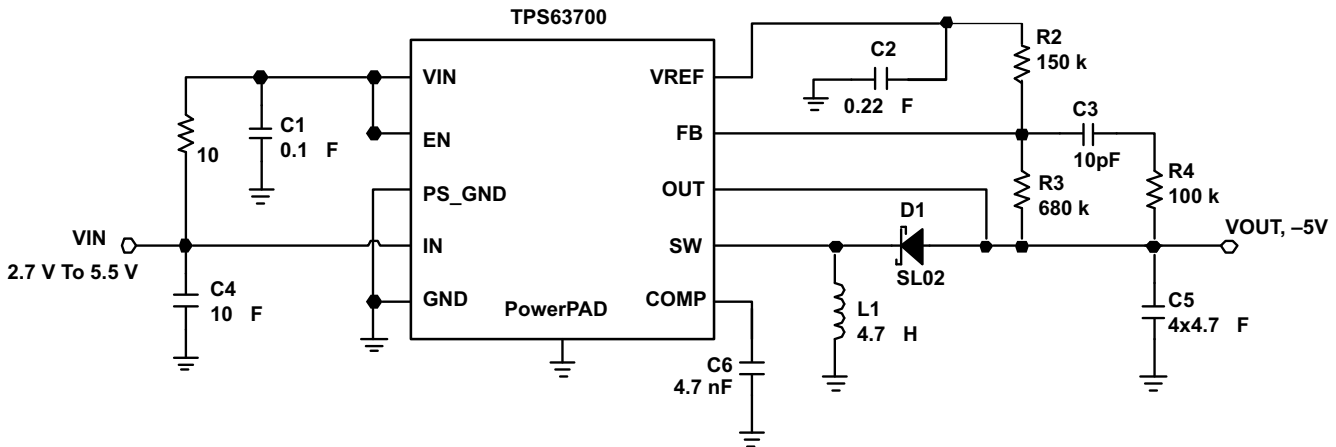

Figure 14. Circuit for –5 Volt Output

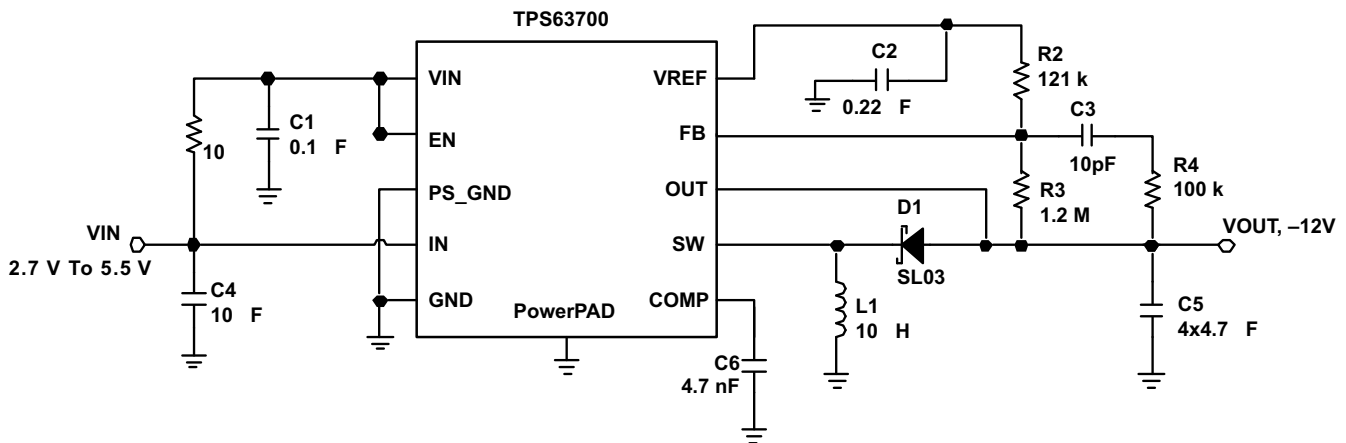

Figure 15. Circuit for –12 Volt Output

Programming the Output Voltage

Converter

The output voltage of the TPS63700 converter can be adjusted with an external resistor divider connected to the FB pin. The reference point of the feedback divider is the reference voltage VREF with 1.213 V. The typical value of the voltage at the FB pin is 0 V. The minimum recommended output voltage at the converter is –15 V. The feedback divider current should be 10 μ A. The voltage across R2 is 1.213 V. Based on those values, the recommended value for R2 should be 120 k Ω to 200 k Ω in order to set the divider current at the required value. The value of the resistor R3 can then be calculated using Equation 1, depending on the needed output voltage (V_{OUT}):

APPLICATION INFORMATION (continued)

$$R3 = R2 \times \left(\frac{V_{REF} - V_{OUT}}{V_{REF}} - 1 \right) \quad (1)$$

For example, if an output voltage of -5 V is needed and a resistor of 150 k Ω has been chosen for $R2$, a 680 -k Ω resistor is needed to program the desired output voltage.

Inductor Selection

An inductive converter normally requires two main passive components for storing energy during the conversion. An inductor and a storage capacitor at the output are required.

The average inductor current depends on the output load, the input voltage (V_{IN}), and the output voltage V_{OUT} . It can be estimated with [Equation 2](#), which shows the formula for the inverting converter.

$$I_{Lavg} = \frac{V_{IN} - V_{OUT}}{V_{IN} \times 0.8} \times I_{OUT} \quad (2)$$

with:

I_{Lavg} = average inductor current

An important parameter for choosing the inductor is the desired current ripple in the inductor.

A ripple current value between 20% and 80% of the average inductor current can be considered as reasonable, depending on the application requirements. A smaller ripple reduces the losses in the inductor, as well as output voltage ripple and EMI. But in the same way, the inductor becomes larger and more expensive.

Keeping those parameters in mind, the possible inductor value can be calculated using [Equation 3](#).

$$L = \frac{V_{IN} \times V_{OUT}}{\Delta I_L \times (V_{OUT} - V_{IN}) \times f} \quad (3)$$

with:

ΔI_L = peak-to-peak ripple current

f = switching frequency

L = inductor value

With the known inductor current ripple, the peak inductor value can be approximated with [Equation 4](#). The peak current through the switch and the inductor depends also on the output load, the input voltage (V_{IN}), and the output voltage (V_{OUT}). To select the right inductor, it is recommended to keep the possible peak inductor current below the current-limit threshold of the power switch. For example, the current-limit threshold of the TPS63700 switch for the inverting converter is nominally 1000 mA.

$$I_{Lmax} = \frac{V_{IN} - V_{OUT}}{V_{IN} \times 0.8} \times I_{OUT} + \frac{\Delta I_L}{2} \quad (4)$$

with:

I_{LMAX} = peak inductor current

With [Equation 5](#), the inductor current ripple at a given inductor can be approximated.

$$\Delta I_L = \frac{V_{IN} \times V_{OUT}}{L \times (V_{OUT} - V_{IN}) \times f} \quad (5)$$

Care has to be taken for the possibility that load transients and losses in the circuit can lead to higher currents as estimated in [Equation 4](#). Also, the losses caused by magnetic hysteresis losses and copper losses are a major parameter for total circuit efficiency.

APPLICATION INFORMATION (continued)

The following inductor series from different suppliers have been tested with the TPS63700 converter:

List of Inductors

Output Voltage	Vendor	SUGGESTED INDUCTOR
-5V	TDK	VL4012 4.7 μ H
		SLF6025-4.7 μ H
-5V	Coilcraft	LPS4018 4.7 μ H
		LPS3015 4.7 μ H
-12V	Sumida	CDRH5D18 10 μ H
-12V	Coilcraft	MOS6020 10 μ H

Capacitor Selection

Input Capacitor

At least a 10- μ F ceramic input capacitor is recommended for a good transient behavior of the regulator, and EMI behavior of the total power supply circuit.

Output Capacitors

One of the major parameters necessary to define the capacitance value of the output capacitor is the maximum allowed output voltage ripple of the converter. This ripple is determined by two parameters of the capacitor, the capacitance and the ESR. It is possible to calculate the minimum capacitance needed for the defined ripple, supposing that the ESR is zero, by using [Equation 6](#) for the inverting converter output capacitor.

$$C_{\min} = \frac{I_{\text{OUT}} \times V_{\text{OUT}}}{f_{\text{S}} \times \Delta V \times (V_{\text{OUT}} - V_{\text{IN}})} \quad (6)$$

Parameter f is the switching frequency and ΔV is the maximum allowed ripple.

With a chosen ripple voltage in the range of 10 mV, a minimum capacitance of 12 μ F is needed. The total ripple is larger due to the ESR of the output capacitor. This additional component of the ripple can be calculated using [Equation 7](#).

$$\Delta V_{\text{ESR}} = I_{\text{OUT}} \times R_{\text{ESR}} \quad (7)$$

An additional ripple of 2 mV is the result of using a typical ceramic capacitor with an ESR in a 10-m Ω range. The total ripple is the sum of the ripple caused by the capacitance, and the ripple caused by the ESR of the capacitor. In this example, the total ripple is 12 mV. Additional ripple is caused by load transients. When the load current increases rapidly, the output capacitor must provide the additional current until the inductor current has been increased by the control loop by setting a higher on-time at the main switch (duty cycle). The higher duty cycle results in longer inductor charging periods. But the rate of increase of the inductor current is also limited by the inductance itself. When the load current decreases rapidly, the output capacitor needs to store the excessive energy (stored in the inductor) until the regulator has decreased the inductor current by reducing the duty cycle. The recommendation is to use higher capacitance values, as the previous calculations show.

Stabilizing the Control Loop

Feedback Divider

To speed up the control loop, a feedforward capacitor of 10 pF is recommended in the feedback divider, parallel to R3.

To avoid coupling noise into the control loop from the feedforward capacitor, the feedforward effect can be bandwidth-limited by adding series resistor R4. A value in the range of 100 k Ω is suitable. The higher the resistance, the lower the noise coupled into the control loop system.

Compensation Capacitor

The control loop of the converter is completely compensated internally. However the internal feedforward system requires an external capacitor. A 4.7-nF capacitor at the COMP pin of the converter is recommended.

Layout Considerations

For all switching power supplies the layout is an important step in the design, especially at high peak currents and high switching frequencies. If the layout is not carefully done, the regulator could show stability problems as well as EMI problems. Therefore, use wide and short traces for the main current paths, and for the power-ground tracks. The input capacitors, output capacitors, the inductors, and the rectifying diodes should be placed as close as possible to the IC to keep parasitic inductances low.

The feedback divider should be placed as close as possible to the VREF pin of the IC. Use short traces when laying out the control ground. [Figure 18](#) is an example layout circuit.

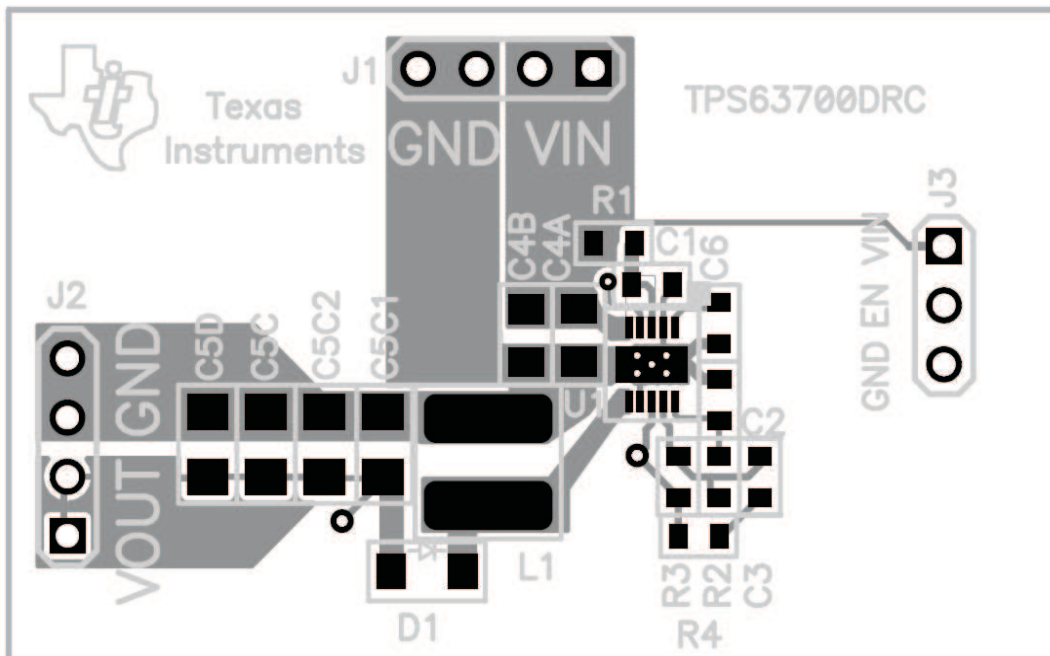

Figure 16. Layout Considerations, Top View

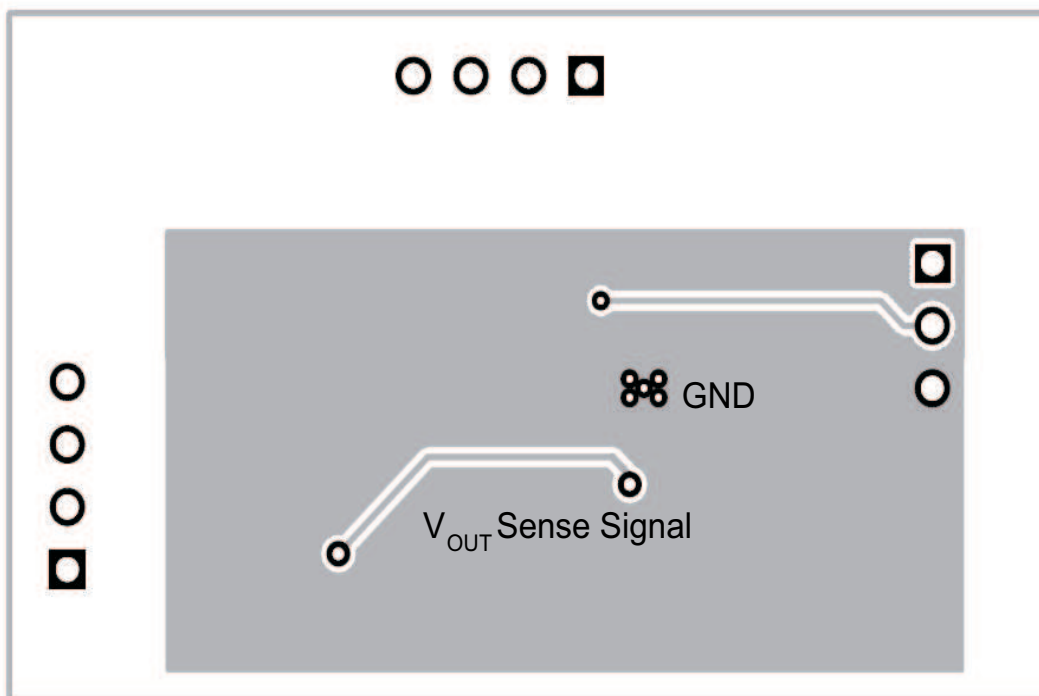

Figure 17. Layout Considerations, Bottom View

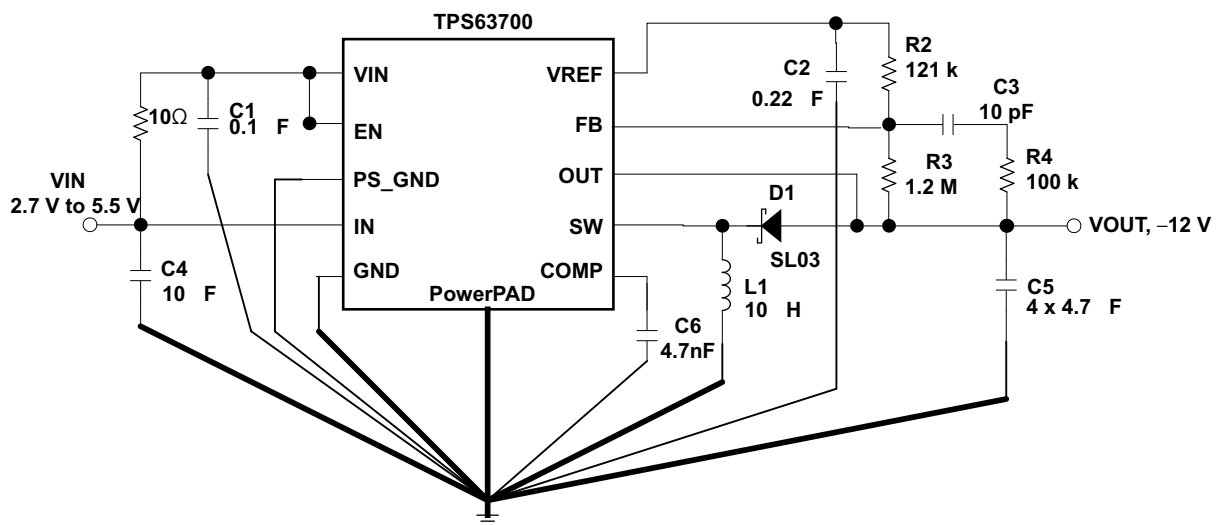

Figure 18. Layout Circuit

THERMAL INFORMATION

Implementation of integrated circuits in low-profile and fine-pitch surface-mount packages typically requires special attention to power dissipation. Many system-dependent issues, such as thermal coupling, airflow, added heatsinks and convection surfaces, and the presence of heat-generating components affect the power-dissipation limits of a given component.

Three basic approaches for enhancing thermal performance are:

- Improving the power dissipation capability of the PCB design
- Improving the thermal coupling of the component to the PCB
- Introducing airflow to the system

The maximum recommended junction temperature (T_J) of the TPS63700 device is 125°C. The thermal resistance of the 10-pin SON, 3x3-mm package (DRC) is $R_{JA} = 48.7^\circ\text{C}/\text{W}$. Specified regulator operation is ensured to a maximum ambient temperature T_A of 85°C. Therefore, the maximum power dissipation is about 821 mW. More power can be dissipated if the maximum ambient temperature of the application is lower.

$$P_{\text{DMAX}} = \frac{T_{\text{JMAX}} - T_A}{R_{\theta\text{JA}}} \quad (8)$$

THERMAL INFORMATION

This package incorporates an exposed thermal pad that is designed to be attached directly to an external heatsink. The thermal pad must be soldered directly to the printed circuit board (PCB), the PCB can be used as a heatsink. In addition, through the use of thermal vias, the thermal pad can be attached directly to a ground plane or special heatsink structure designed into the PCB. This design optimizes the heat transfer from the integrated circuit (IC).

For information on the Quad Flatpack No-Lead (QFN) package and its advantages, refer to Application Report, Quad Flatpack No-Lead Logic Packages, Texas Instruments Literature No. SCBA017. This document is available at www.ti.com.

The exposed thermal pad dimensions for this package are shown in the following illustration.

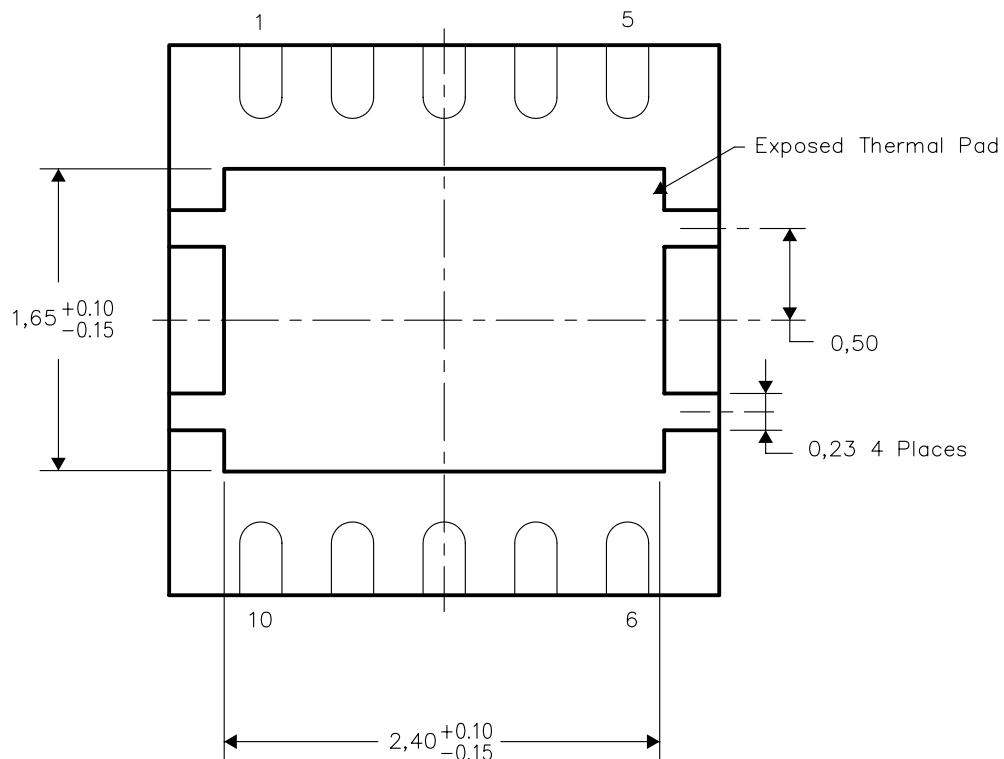

Bottom View

NOTE: All linear dimensions are in millimeters

Exposed Thermal Pad Dimensions

PACKAGING INFORMATION

Orderable Device	Status ⁽¹⁾	Package Type	Package Drawing	Pins	Package Qty	Eco Plan ⁽²⁾	Lead/Ball Finish	MSL Peak Temp ⁽³⁾
TPS63700DRCR	ACTIVE	SON	DRC	10	3000	Green (RoHS & no Sb/Br)	CU NIPDAU	Level-2-260C-1 YEAR
TPS63700DRCRG4	ACTIVE	SON	DRC	10	3000	Green (RoHS & no Sb/Br)	CU NIPDAU	Level-2-260C-1 YEAR
TPS63700DRCT	ACTIVE	SON	DRC	10	250	Green (RoHS & no Sb/Br)	CU NIPDAU	Level-2-260C-1 YEAR
TPS63700DRCTG4	ACTIVE	SON	DRC	10	250	Green (RoHS & no Sb/Br)	CU NIPDAU	Level-2-260C-1 YEAR

⁽¹⁾ The marketing status values are defined as follows:

ACTIVE: Product device recommended for new designs.

LIFEBUY: TI has announced that the device will be discontinued, and a lifetime-buy period is in effect.

NRND: Not recommended for new designs. Device is in production to support existing customers, but TI does not recommend using this part in a new design.

PREVIEW: Device has been announced but is not in production. Samples may or may not be available.

OBSOLETE: TI has discontinued the production of the device.

⁽²⁾ Eco Plan - The planned eco-friendly classification: Pb-Free (RoHS) or Green (RoHS & no Sb/Br) - please check <http://www.ti.com/productcontent> for the latest availability information and additional product content details.

TBD: The Pb-Free/Green conversion plan has not been defined.

Pb-Free (RoHS): TI's terms "Lead-Free" or "Pb-Free" mean semiconductor products that are compatible with the current RoHS requirements for all 6 substances, including the requirement that lead not exceed 0.1% by weight in homogeneous materials. Where designed to be soldered at high temperatures, TI Pb-Free products are suitable for use in specified lead-free processes.

Green (RoHS & no Sb/Br): TI defines "Green" to mean Pb-Free (RoHS compatible), and free of Bromine (Br) and Antimony (Sb) based flame retardants (Br or Sb do not exceed 0.1% by weight in homogeneous material)

⁽³⁾ MSL, Peak Temp. -- The Moisture Sensitivity Level rating according to the JEDEC industry standard classifications, and peak solder temperature.

Important Information and Disclaimer:The information provided on this page represents TI's knowledge and belief as of the date that it is provided. TI bases its knowledge and belief on information provided by third parties, and makes no representation or warranty as to the accuracy of such information. Efforts are underway to better integrate information from third parties. TI has taken and continues to take reasonable steps to provide representative and accurate information but may not have conducted destructive testing or chemical analysis on incoming materials and chemicals. TI and TI suppliers consider certain information to be proprietary, and thus CAS numbers and other limited information may not be available for release.



In no event shall TI's liability arising out of such information exceed the total purchase price of the TI part(s) at issue in this document sold by TI to Customer on an annual basis.

DRC (S-PDSO-N10)

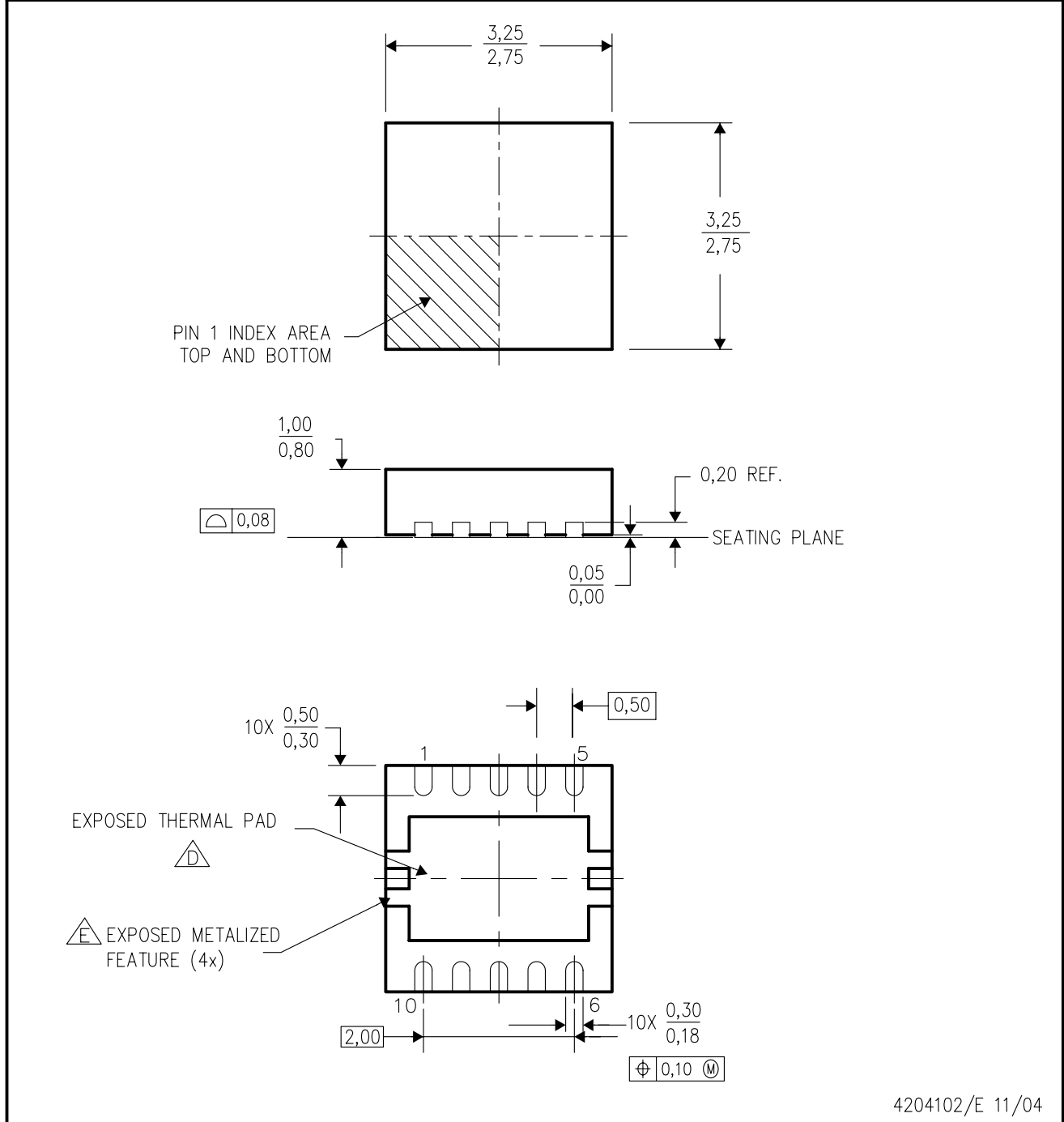
PLASTIC SMALL OUTLINE



4204102/E 11/04

- NOTES:
- A. All linear dimensions are in millimeters. Dimensioning and tolerancing per ASME Y14.5M-1994.
 - B. This drawing is subject to change without notice.
 - C. Small Outline No-Lead (SON) package configuration.
 -  The package thermal pad must be soldered to the board for thermal and mechanical performance. See the Product Data Sheet for details regarding the exposed thermal pad dimensions.
 -  Metalized features are supplier options and may not be on the package.

IMPORTANT NOTICE

Texas Instruments Incorporated and its subsidiaries (TI) reserve the right to make corrections, modifications, enhancements, improvements, and other changes to its products and services at any time and to discontinue any product or service without notice. Customers should obtain the latest relevant information before placing orders and should verify that such information is current and complete. All products are sold subject to TI's terms and conditions of sale supplied at the time of order acknowledgment.

TI warrants performance of its hardware products to the specifications applicable at the time of sale in accordance with TI's standard warranty. Testing and other quality control techniques are used to the extent TI deems necessary to support this warranty. Except where mandated by government requirements, testing of all parameters of each product is not necessarily performed.

TI assumes no liability for applications assistance or customer product design. Customers are responsible for their products and applications using TI components. To minimize the risks associated with customer products and applications, customers should provide adequate design and operating safeguards.

TI does not warrant or represent that any license, either express or implied, is granted under any TI patent right, copyright, mask work right, or other TI intellectual property right relating to any combination, machine, or process in which TI products or services are used. Information published by TI regarding third-party products or services does not constitute a license from TI to use such products or services or a warranty or endorsement thereof. Use of such information may require a license from a third party under the patents or other intellectual property of the third party, or a license from TI under the patents or other intellectual property of TI.

Reproduction of information in TI data books or data sheets is permissible only if reproduction is without alteration and is accompanied by all associated warranties, conditions, limitations, and notices. Reproduction of this information with alteration is an unfair and deceptive business practice. TI is not responsible or liable for such altered documentation.

Resale of TI products or services with statements different from or beyond the parameters stated by TI for that product or service voids all express and any implied warranties for the associated TI product or service and is an unfair and deceptive business practice. TI is not responsible or liable for any such statements.

Following are URLs where you can obtain information on other Texas Instruments products and application solutions:

Products		Applications	
Amplifiers	amplifier.ti.com	Audio	www.ti.com/audio
Data Converters	dataconverter.ti.com	Automotive	www.ti.com/automotive
DSP	dsp.ti.com	Broadband	www.ti.com/broadband
Interface	interface.ti.com	Digital Control	www.ti.com/digitalcontrol
Logic	logic.ti.com	Military	www.ti.com/military
Power Mgmt	power.ti.com	Optical Networking	www.ti.com/opticalnetwork
Microcontrollers	microcontroller.ti.com	Security	www.ti.com/security
		Telephony	www.ti.com/telephony
		Video & Imaging	www.ti.com/video
		Wireless	www.ti.com/wireless

Mailing Address: Texas Instruments
Post Office Box 655303 Dallas, Texas 75265