

## 2.25-MHz, 600-mA Step-Down Converter in TSOT and 2- x 2- x 0,8-mm SON Package

### FEATURES

- High-Efficiency Step-Down Converter
- Output Current up to 600 mA
- Wide  $V_{IN}$  Range from 2.5 V to 5.5 V for Li-Ion Batteries With Extended Voltage Range
- Adjustable and Fixed Output-Voltage Options
- 2.25-MHz Fixed-Frequency Operation
- Power-Save Mode at Light Load Currents
- Output Voltage Accuracy in PWM Mode  $\pm 2.5\%$
- Typical 15- $\mu$ A Quiescent Current
- 100% Duty Cycle for Lowest Dropout
- Soft Start
- Voltage Positioning at Light Loads
- Available in a Small TSOT, and 2-mm x 2-mm x 0,8-mm SON Package
- Allows < 1-mm Solution Height

### APPLICATIONS

- PDAs, Pocket PCs, Portable Media Players
- Low-Power DSP Supply
- POL Applications

### DESCRIPTION

The TPS6256x devices are efficient synchronous step-down dc-dc converters optimized for battery-powered applications. They provide up to 600-mA output current from a single Li-Ion cell and are ideal to power mobile phones and other portable applications.

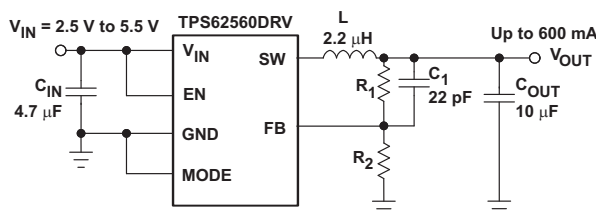

With a wide input voltage range of 2.5 V to 5.5 V, the devices support applications powered by Li-Ion batteries with extended voltage range, two- and three-cell alkaline batteries, 3.3-V and 5-V input voltage rails. They operate at 2.25-MHz fixed switching frequency and enter power-save mode operation at light load currents to maintain high efficiency over the entire load-current range.

The power-save mode is optimized for low output-voltage ripple. For low-noise applications, the devices can be forced into the fixed-frequency PWM mode by pulling the MODE terminal high. In shutdown mode, the current consumption is reduced to less than 1  $\mu$ A. Switching at 2.25-MHz allows the use of small inductors and capacitors to achieve a small solution size.

Operating in a forced fixed-frequency PWM mode, the TPS62561 devices allow simple filtering of the switching frequency, e.g., for noise-sensitive applications.

TPS62560 and TPS62562 are available in a 2-mm x 2-mm 6-terminal SON package, whereas TPS62561 is available in a 5-terminal TSOT23 package. Providing a fixed-output-voltage version, this TPS62562 enables a even smaller solution size with no external resistors needed.

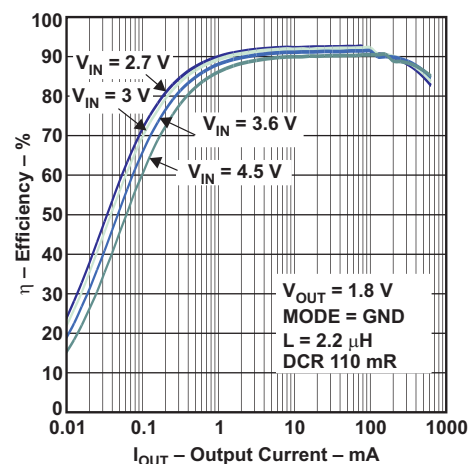

Please be aware that an important notice concerning availability, standard warranty, and use in critical applications of Texas Instruments semiconductor products and disclaimers thereto appears at the end of this data sheet.



This integrated circuit can be damaged by ESD. Texas Instruments recommends that all integrated circuits be handled with appropriate precautions. Failure to observe proper handling and installation procedures can cause damage.

ESD damage can range from subtle performance degradation to complete device failure. Precision integrated circuits may be more susceptible to damage because very small parametric changes could cause the device not to meet its published specifications.

### ORDERING INFORMATION

T <sub>A</sub>	PART NUMBER <sup>(1)</sup>	OUTPUT VOLTAGE <sup>(2)</sup>	PACKAGE <sup>(3)</sup>	PACKAGE DESIGNATOR	ORDERING	PACKAGE MARKING
–40°C to 85°C	TPS62560	Adjustable	SON 2x2-6	DRV	TPS62560DRV	CEY
–40°C to 85°C	TPS62561	Adjustable	TSOT-23-5	DDC	TPS62561DDC	CVO
–40°C to 85°C	TPS62562	1.8-V fixed	SON 2x2-6	DRV	TPS62562DRV	NXT

- (1) The DRV (2-mm x 2-mm 6-terminal SON) and the DDC (TSOT-23-5) packages are available in tape on reel. Add R suffix to order quantities of 3000 parts per reel and T suffix to order quantities with 250 parts per reel.
- (2) Contact TI for other fixed-output-voltage options.
- (3) For the most-current package and ordering information, see the Package Option Addendum at the end of this document, or see the TI Web site at [www.ti.com](http://www.ti.com).

### ABSOLUTE MAXIMUM RATINGS

over operating free-air temperature range (unless otherwise noted)<sup>(1)</sup>

		VALUE	UNIT
Input voltage range <sup>(2)</sup>		–0.3 to 7	V
Voltage range at EN, MODE		–0.3 to V <sub>IN</sub> +0.3, ≤ 7	
Voltage on SW		–0.3 to 7	
Peak output current		Internally limited	A
ESD rating <sup>(3)</sup>	HBM human-body model	2	kV
	CDM charged-device model	1	
	Machine model	200	V
T <sub>J</sub>	Maximum operating junction temperature	–40 to 125	°C
T <sub>stg</sub>	Storage temperature range	–65 to 150	°C

- (1) Stresses beyond those listed under *absolute maximum ratings* may cause permanent damage to the device. These are stress ratings only and functional operation of the device at these or any other conditions beyond those indicated under *recommended operating conditions* is not implied. Exposure to absolute-maximum-rated conditions for extended periods may affect device reliability.
- (2) All voltage values are with respect to the network ground terminal.
- (3) The human-body model is a 100-pF capacitor discharged through a 1.5-kΩ resistor into each terminal. The machine model is a 200-pF capacitor discharged directly into each terminal.

### DISSIPATION RATINGS

PACKAGE	R <sub>θJA</sub>	POWER RATING FOR T <sub>A</sub> ≤ 25°C	DERATING FACTOR ABOVE T <sub>A</sub> = 25°C
DRV	76°C/W	1300 mW	13 mW/°C
DDC	250°C/W	400 mW	4 mW/°C

### RECOMMENDED OPERATING CONDITIONS

		MIN	NOM	MAX	UNIT
V <sub>IN</sub>	Supply voltage	2.5		5.5	V
	Output voltage range for adjustable voltage	0.85		V <sub>IN</sub>	V
T <sub>A</sub>	Operating ambient temperature	–40		85	°C
T <sub>J</sub>	Operating junction temperature	–40		125	°C

## ELECTRICAL CHARACTERISTICS

Over full operating ambient temperature range, typical values are at  $T_A = 25^\circ\text{C}$ . Unless otherwise noted, specifications apply for condition  $V_{IN} = EN = 3.6\text{ V}$ . External components  $C_{IN} = 4.7\ \mu\text{F}$  0603,  $C_{OUT} = 10\ \mu\text{F}$  0603,  $L = 2.2\ \mu\text{H}$ ; see the [Parameter Measurement Information](#) section.

PARAMETER		TEST CONDITIONS	MIN	TYP	MAX	UNIT
<b>SUPPLY</b>						
$V_{IN}$	Input voltage range		2.5		5.5	V
$I_{OUT}$	Output current	$V_{IN} = 2.5\text{ V to }5.5\text{ V}$			600	mA
$I_Q$	Operating quiescent current	$I_{OUT} = 0\text{ mA}$ , PFM mode enabled (MODE = GND), device not switching		15		$\mu\text{A}$
		$I_{OUT} = 0\text{ mA}$ , PFM mode enabled (MODE = GND), device switching, $V_{OUT} = 1.8\text{ V}$ , See <sup>(1)</sup>		18.5		
		$I_{OUT} = 0\text{ mA}$ , switching with no load (MODE = $V_{IN}$ ), PWM operation, $V_{OUT} = 1.8\text{ V}$ , $V_{IN} = 3\text{ V}$		3.8		mA
$I_{SD}$	Shutdown current	EN = GND		0.5		$\mu\text{A}$
UVLO	Undervoltage lockout threshold	Falling		1.85		V
		Rising		1.95		
<b>ENABLE, MODE</b>						
$V_{IH}$	High-level input voltage, EN, MODE	$2\text{ V} \leq V_{IN} \leq 5.5\text{ V}$	1		$V_{IN}$	V
$V_{IL}$	Low-level input voltage, EN, MODE	$2\text{ V} \leq V_{IN} \leq 5.5\text{ V}$	0		0.4	V
$I_{IN}$	Input bias current, EN, MODE	EN, MODE = GND or $V_{IN}$		0.01	1	$\mu\text{A}$
<b>POWER SWITCH</b>						
$R_{DS(on)}$	High side MOSFET on-resistance	$V_{IN} = V_{GS} = 3.6\text{ V}$ , $T_A = 25^\circ\text{C}$		252	492	m $\Omega$
	Low side MOSFET on-resistance			194	391	
$I_{LIMF}$	Forward current limit, high and low side MOSFET	$V_{IN} = V_{GS} = 3.6\text{ V}$	0.8	1	1.2	A
$T_{SD}$	Thermal shutdown	Increasing junction temperature		140		$^\circ\text{C}$
	Thermal-shutdown hysteresis	Decreasing junction temperature		20		
<b>OSCILLATOR</b>						
$f_{SW}$	Oscillator frequency	$2\text{ V} \leq V_{IN} \leq 5.5\text{ V}$		2.25		MHz
<b>OUTPUT</b>						
$V_{OUT}$	Adjustable-output voltage range		0.85		$V_{IN}$	V
$V_{OUT}$	TPS62562 fixed output voltage	( $V_{IN} \geq 1.8\text{ V}$ )		1.8		V
$V_{ref}$	Reference voltage			600		mV
$V_{FB}$	Feedback voltage, PWM mode	MODE = $V_{IN}$ , PWM operation, for fixed-output-voltage versions $V_{FB} = V_{OUT}$ , $2.5\text{ V} \leq V_{IN} \leq 5.5\text{ V}$ , $0\text{ mA} \leq I_{OUT} \leq 600\text{ mA}$ <sup>(2)</sup>	-2.5%	0%	2.5%	
	Feedback voltage, PFM mode	MODE = GND, device in PFM mode, voltage positioning active <sup>(1)</sup>		1%		
	Load regulation	PWM mode		-1		
$t_{Start Up}$	Start-up time	Time from active EN to reach 95% of $V_{OUT}$ nominal		500		$\mu\text{s}$
$t_{Ramp}$	$V_{OUT}$ ramp-up time	Time to ramp from 5% to 95% of $V_{OUT}$		250		$\mu\text{s}$
$I_{lkg}$	Leakage current into SW terminal	$V_{IN} = 3.6\text{ V}$ , $V_{IN} = V_{OUT} = V_{SW}$ , EN = GND <sup>(3)</sup>		0.5	1	$\mu\text{A}$

(1) In PFM mode, the internal reference voltage is set to typ.  $1.01 \times V_{ref}$ . See the [Parameter Measurement Information](#) section.

(2) For  $V_{IN} = V_{OUT} + 0.6\text{ V}$

(3) In fixed-output-voltage versions, the internal resistor divider network is disconnected from the FB terminal.

## PIN ASSIGNMENTS

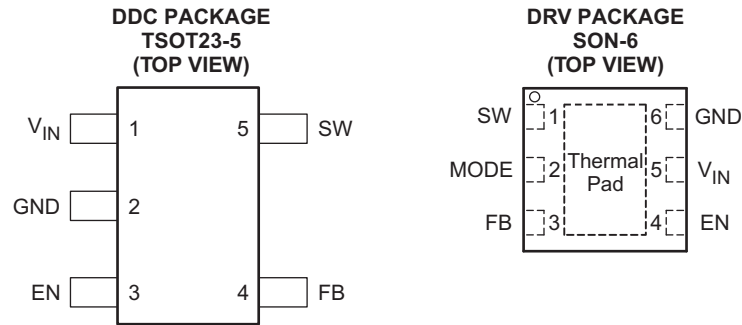
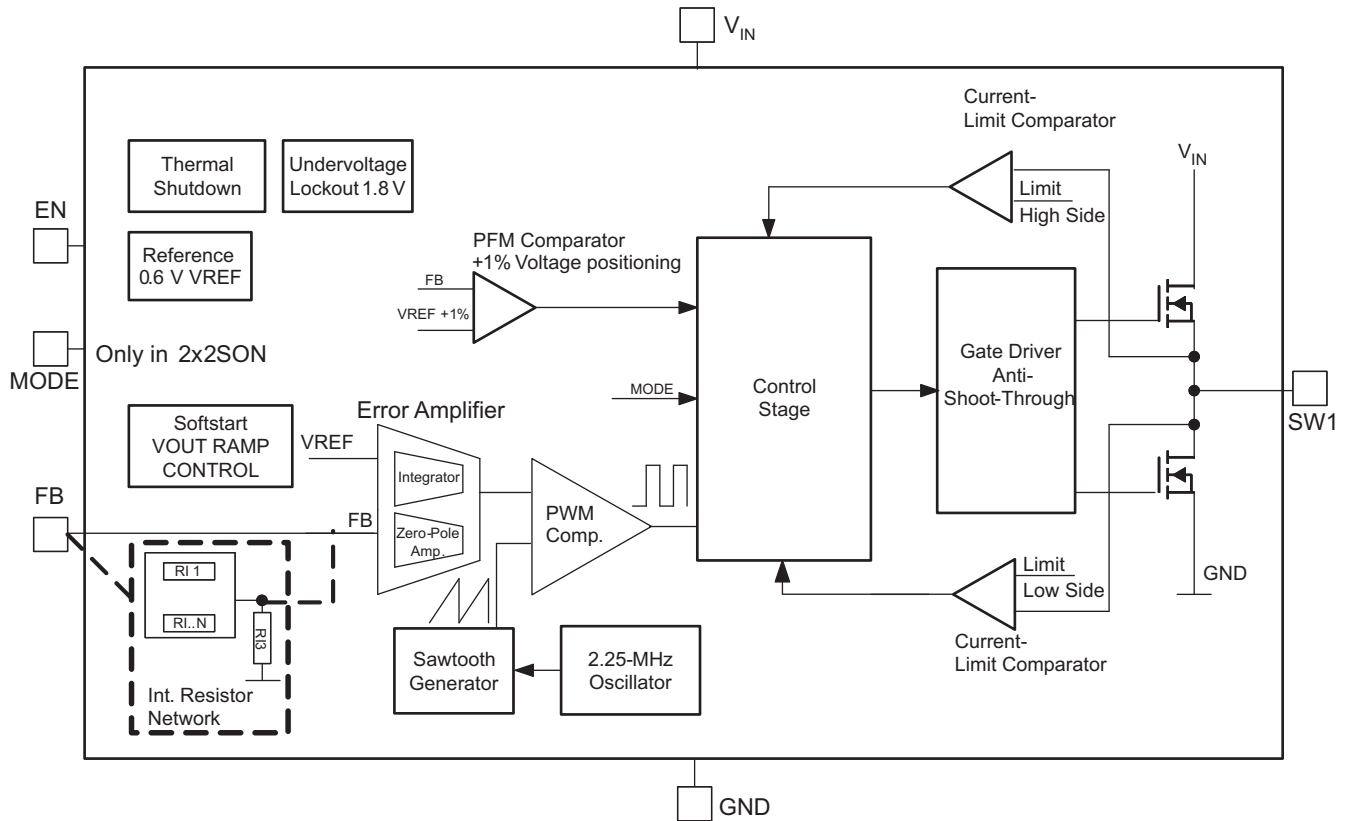

Figure 1.

## PIN FUNCTIONS

NAME	PIN		I/O	DESCRIPTION
	No. SON-6	No. TSOT23-5		
EN	4	3	I	This is the enable terminal of the device. Pulling this terminal to low forces the device into shutdown mode. Pulling this terminal to high enables the device. This terminal must be terminated.
FB	3	4	I	Feedback terminal for the internal regulation loop. Connect the external resistor divider to this terminal. In the fixed-output-voltage option, connect this terminal directly to the output capacitor.
GND	6	2	—	GND supply terminal
MODE	2	—	I	This terminal is only available as an SON package option. MODE terminal = high forces the device to operate in the fixed-frequency PWM mode. MODE terminal = low enables the power-save mode with automatic transition from PFM mode to fixed-frequency PWM mode.
SW	1	5	O	This is the switch terminal and is connected to the internal MOSFET switches. Connect the external inductor between this terminal and the output capacitor.
V <sub>IN</sub>	5	1	—	V <sub>IN</sub> power-supply terminal

FUNCTIONAL BLOCK DIAGRAM



PARAMETER MEASUREMENT INFORMATION

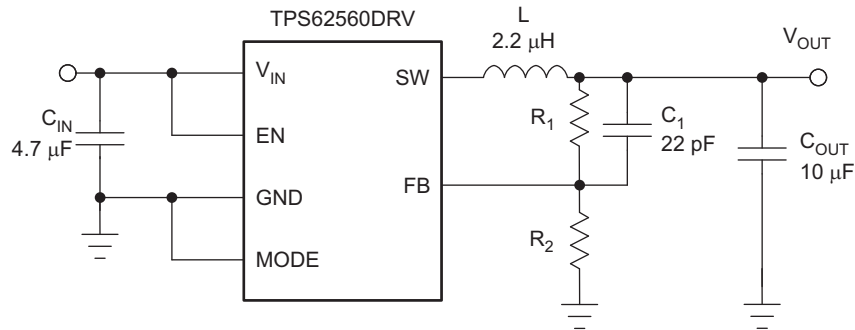

- L: LPS3015, 2.2  $\mu$ H, 110 m $\Omega$
- C<sub>IN</sub>: GRM188R60J475K, 4.7  $\mu$ F, Murata, 0603 size
- C<sub>OUT</sub>: GRM188R60J106M, 10  $\mu$ F, Murata, 0603 size

## TYPICAL CHARACTERISTICS

### Table of Graphs

		FIGURE
$\eta$ Efficiency	vs Output Current, $V_{OUT} = 1.8\text{ V}$ , Power Save Mode, MODE = GND	<a href="#">Figure 2</a>
	vs Output Current, $V_{OUT} = 1.8\text{ V}$ , PWM Mode, MODE = $V_{IN}$	<a href="#">Figure 3</a>
	vs Output Current, $V_{OUT} = 3.3\text{ V}$ , PWM Mode, MODE = $V_{IN}$	<a href="#">Figure 4</a>
	vs Output Current, $V_{OUT} = 3.3\text{ V}$ , Power Save Mode, MODE = GND	<a href="#">Figure 5</a>
	vs Output Current, MODE = $V_{IN}$	<a href="#">Figure 6</a>
	vs Output Current, MODE = GND	<a href="#">Figure 7</a>
Typical Operation	PWM Mode, $V_{OUT} = 1.8\text{ V}$	<a href="#">Figure 8</a>
Mode Transition	MODE Terminal Transition From PFM to Forced PWM Mode at Light Load	<a href="#">Figure 9</a>
	MODE Terminal Transition From Forced PWM to PFM Mode at Light Load	<a href="#">Figure 10</a>
Start-up Timing		<a href="#">Figure 11</a>
Load Transient	Forced PWM Mode, $V_{OUT} = 1.5\text{ V}$ , 50 mA to 200 mA	<a href="#">Figure 12</a>
	Forced PWM Mode, $V_{OUT} = 1.5\text{ V}$ , 200 mA to 400 mA	<a href="#">Figure 13</a>
	Forced PFM Mode to PWM Mode, $V_{OUT} = 1.5\text{ V}$ , 150 $\mu\text{A}$ to 400 mA	<a href="#">Figure 14</a>
	Forced PWM Mode to PFM Mode, $V_{OUT} = 1.5\text{ V}$ , 400 mA to 150 $\mu\text{A}$	<a href="#">Figure 15</a>
	PFM Mode, $V_{OUT} = 1.5\text{ V}$ , 1.5 mA to 50 mA	<a href="#">Figure 16</a>
	PFM Mode, $V_{OUT} = 1.5\text{ V}$ , 50 mA to 1.5 mA	<a href="#">Figure 17</a>
	PFM Mode to PWM Mode, $V_{OUT} = 1.8\text{ V}$ , 50 mA to 250 mA	<a href="#">Figure 18</a>
	PFM Mode to PWM Mode, $V_{OUT} = 1.5\text{ V}$ , 50 mA to 400 mA	<a href="#">Figure 19</a>
	PWM Mode to PFM Mode, $V_{OUT} = 1.5\text{ V}$ , 400 mA to 50 mA	<a href="#">Figure 20</a>
Line Transient	PFM Mode, $V_{OUT} = 1.8\text{ V}$ , 50 mA	<a href="#">Figure 21</a>
	PFM Mode, $V_{OUT} = 1.8\text{ V}$ , 250 mA	<a href="#">Figure 22</a>
Typical Operation	PFM Mode, $V_{OUT}$ Ripple, $V_{OUT} = 1.8\text{ V}$ , 10 mA, $L = 2.2\text{ }\mu\text{H}$ , $C_{OUT} = 10\text{ }\mu\text{F}$	<a href="#">Figure 23</a>
	PFM Mode, $V_{OUT}$ Ripple, $V_{OUT} = 1.8\text{ V}$ , 10 mA, $L = 4.7\text{ }\mu\text{H}$ , $C_{OUT} = 10\text{ }\mu\text{F}$	<a href="#">Figure 24</a>
Quiescent Current	vs Input Voltage, ( $T_A = 85^\circ\text{C}$ , $T_A = 25^\circ\text{C}$ , $T_A = -40^\circ\text{C}$ )	<a href="#">Figure 25</a>
Static Drain-Source On-State Resistance	vs Input Voltage, ( $T_A = 85^\circ\text{C}$ , $T_A = 25^\circ\text{C}$ , $T_A = -40^\circ\text{C}$ ), High-Side Switching	<a href="#">Figure 26</a>
	vs Input Voltage, ( $T_A = 85^\circ\text{C}$ , $T_A = 25^\circ\text{C}$ , $T_A = -40^\circ\text{C}$ ), Low-Side Switching	<a href="#">Figure 27</a>

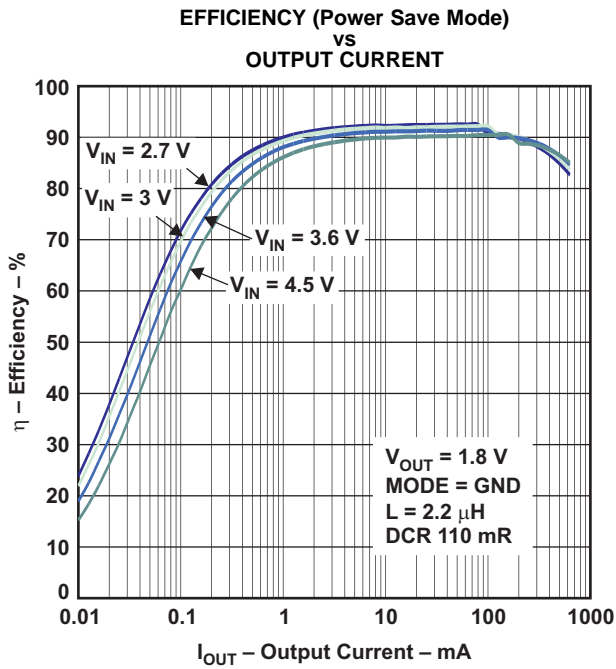

Figure 2.

G002

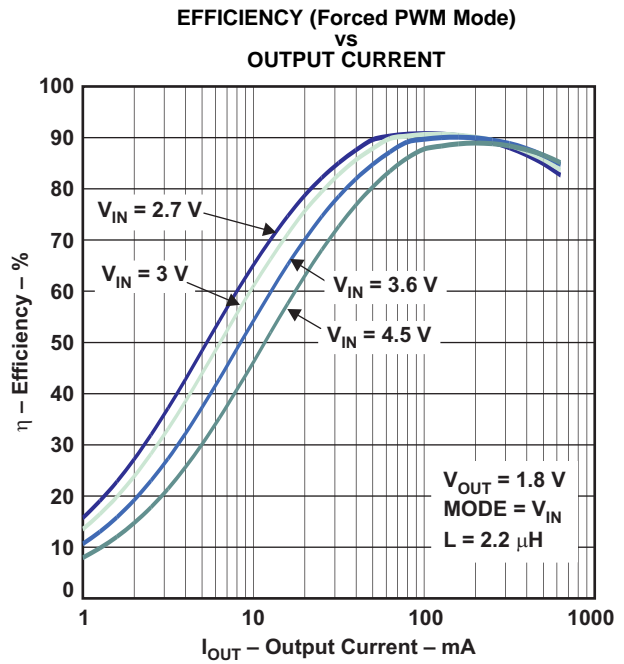

Figure 3.

G003

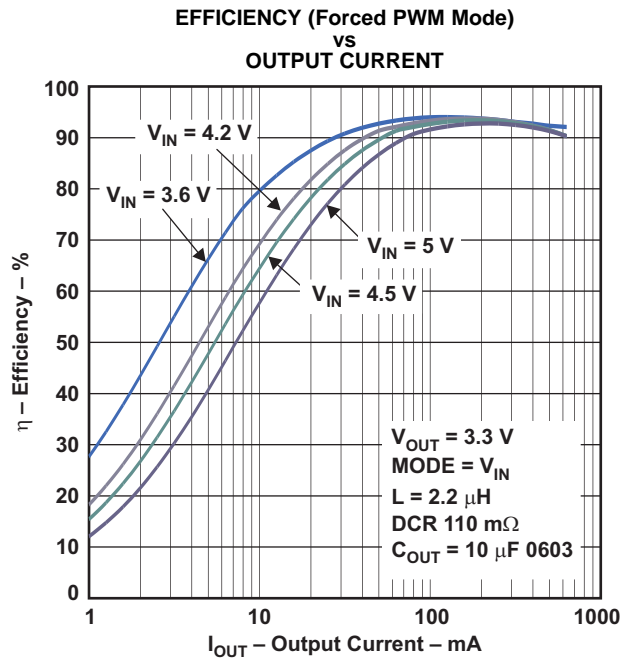

Figure 4.

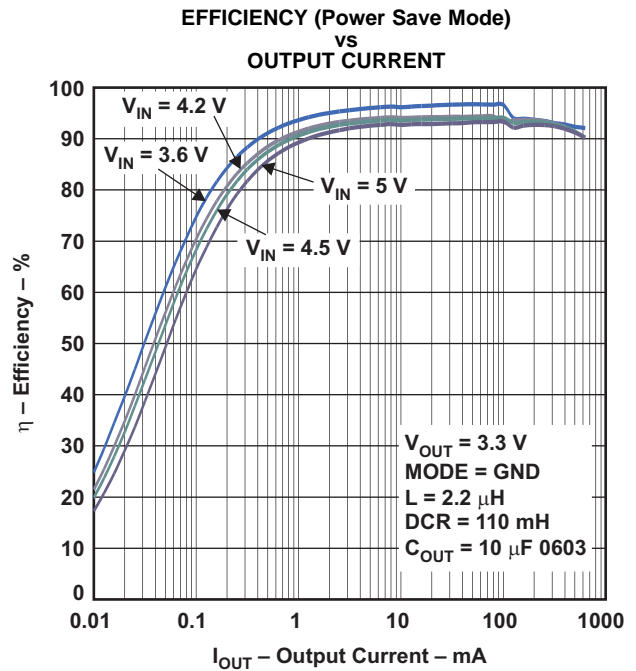

Figure 5.

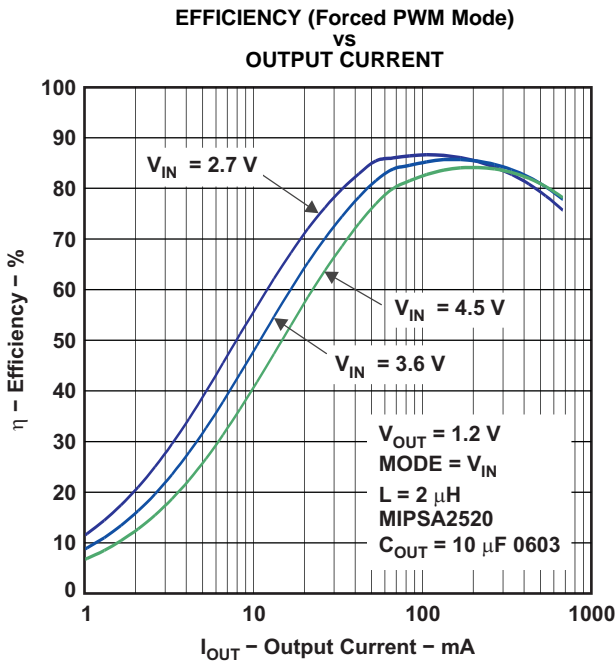

Figure 6.

G004

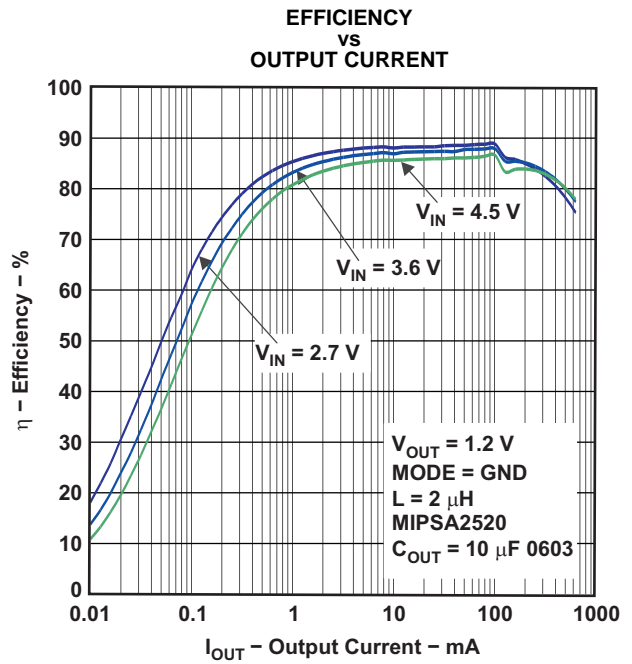

Figure 7.

G005

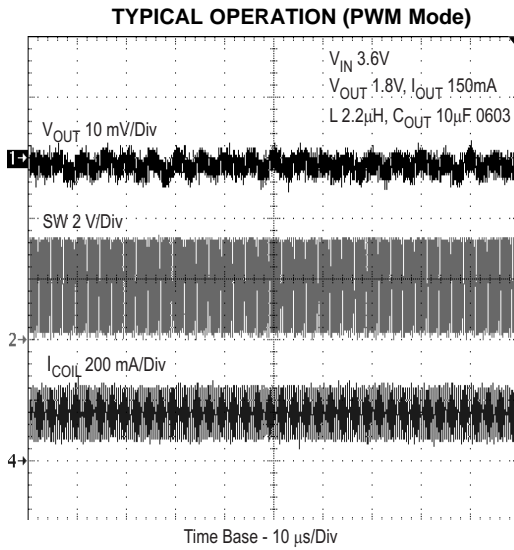

Figure 8.

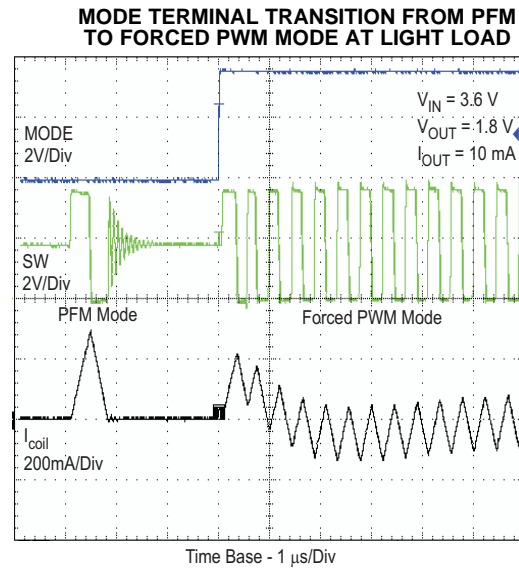
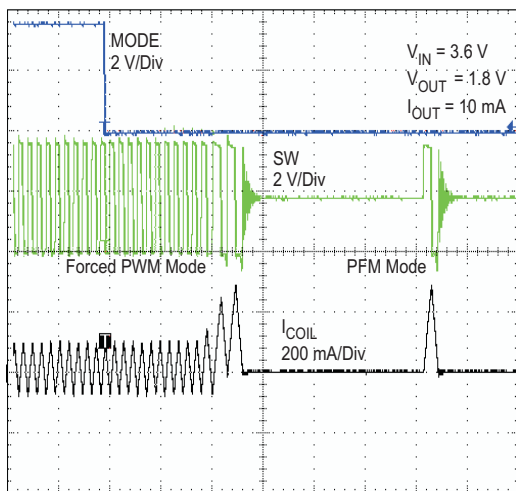

Figure 9.



**MODE TERMINAL TRANSITION FROM PWM TO PFM MODE AT LIGHT LOAD**



**Figure 10.**

**START-UP TIMING**

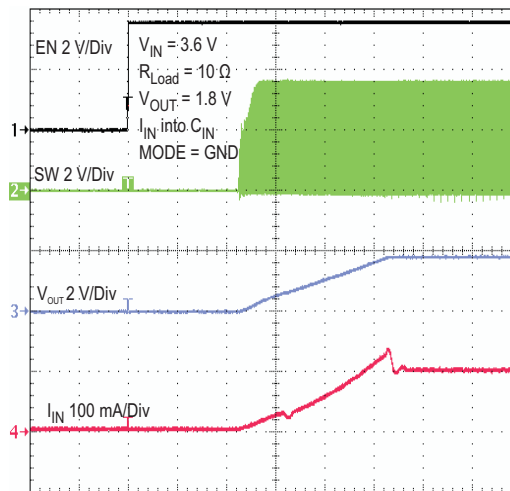

**Figure 11.**

**LOAD TRANSIENT (Forced PWM Mode)**

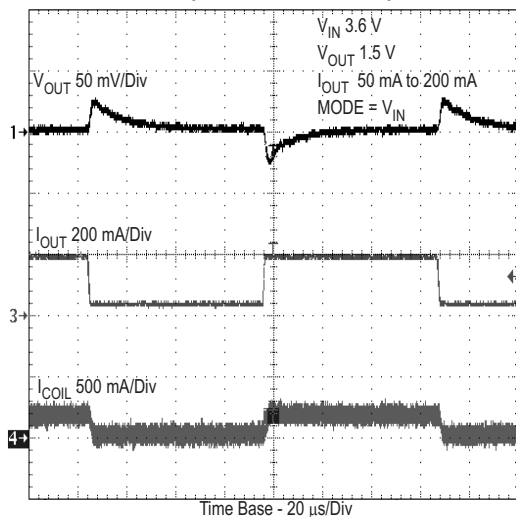

**Figure 12.**

**LOAD TRANSIENT (Forced PWM Mode)**

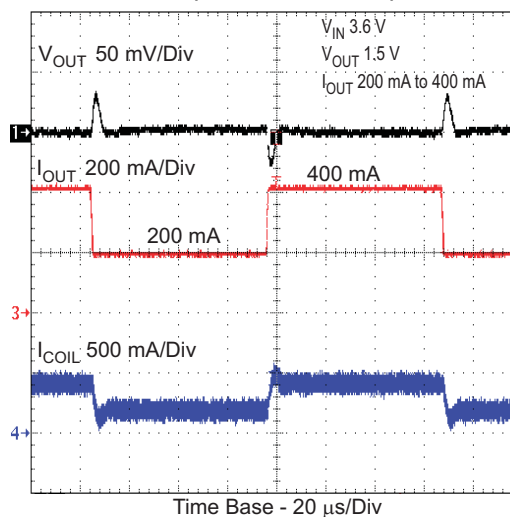

**Figure 13.**

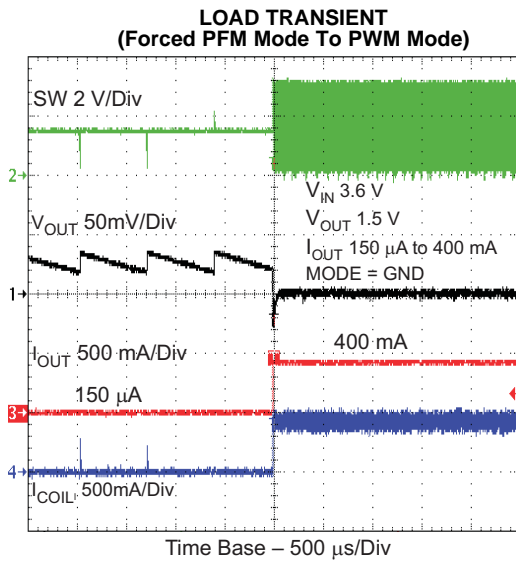

Figure 14.

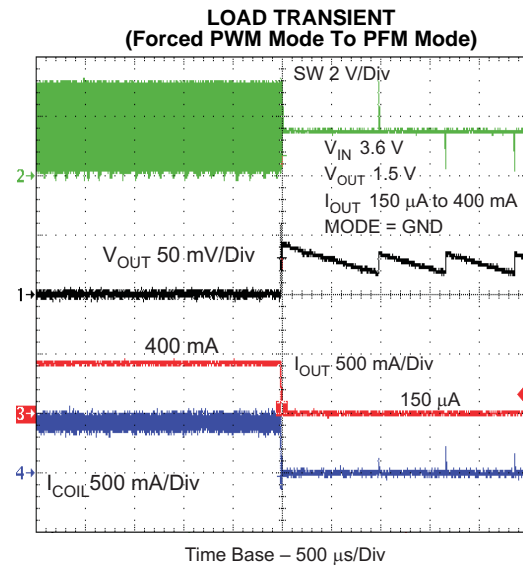

Figure 15.

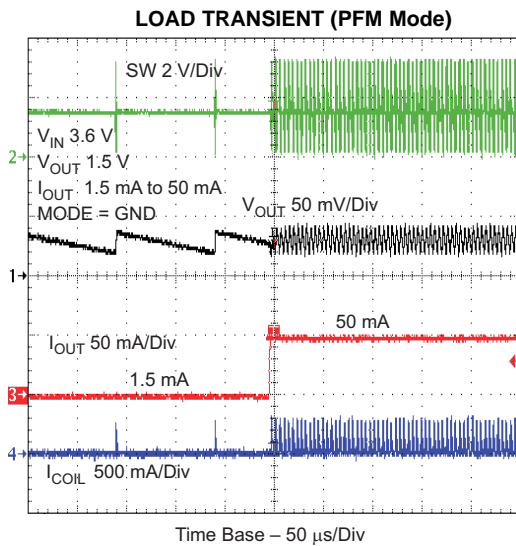

Figure 16.

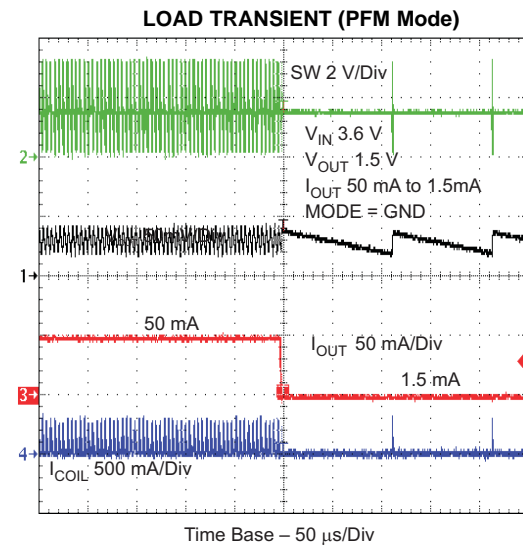
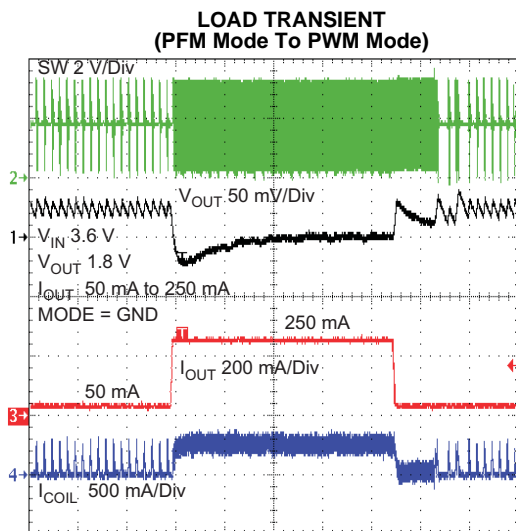
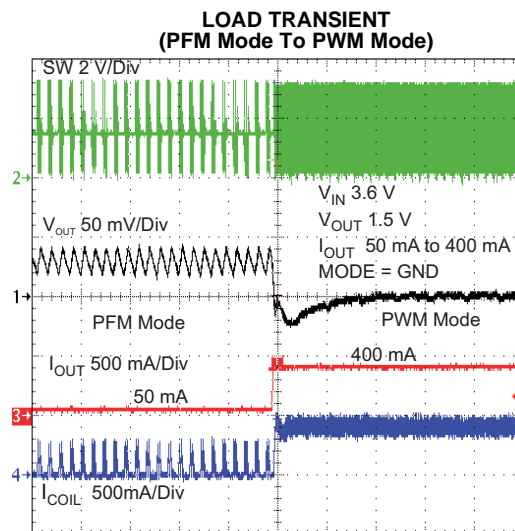

Figure 17.



Time Base – 20 µs/Div

Figure 18.



Time Base – 20 µs/Div

Figure 19.

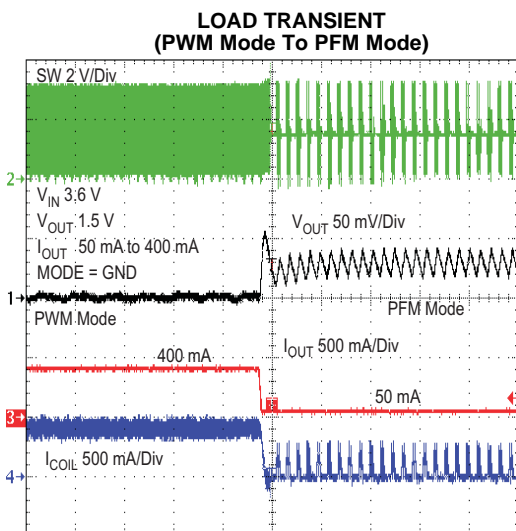

Time Base – 20 µs/Div

Figure 20.

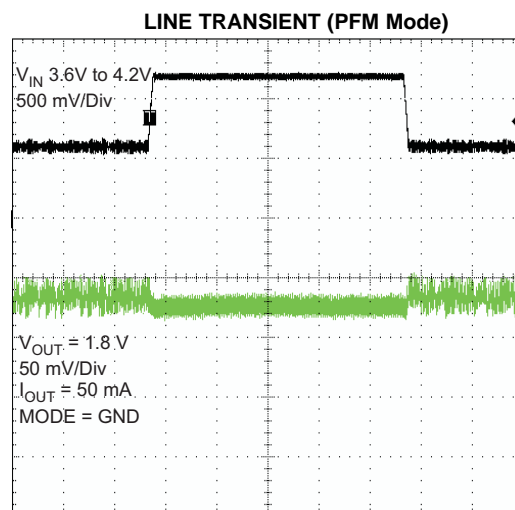

Figure 21.

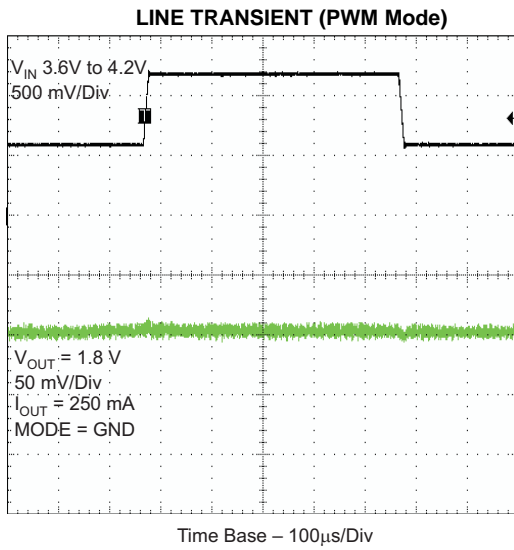

Figure 22.

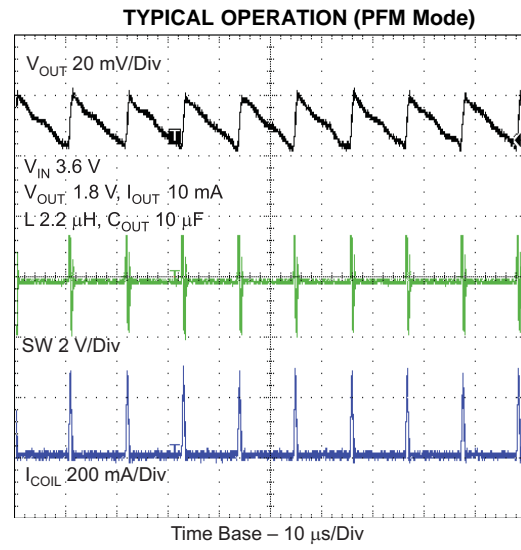

Figure 23.

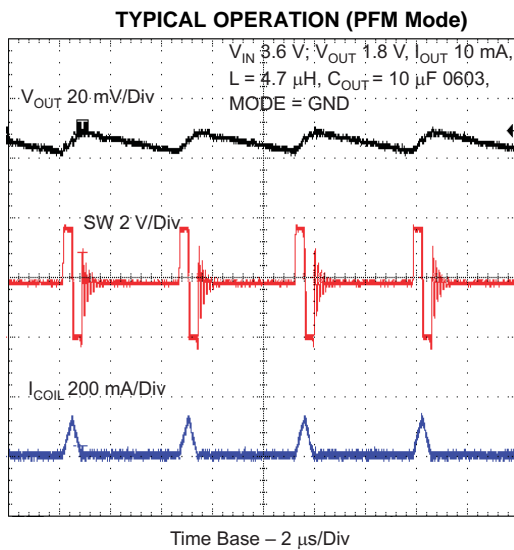
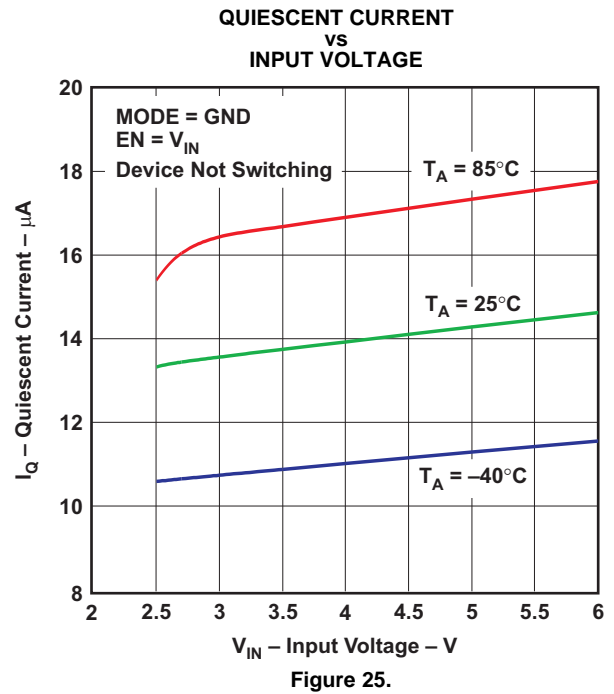

Figure 24.



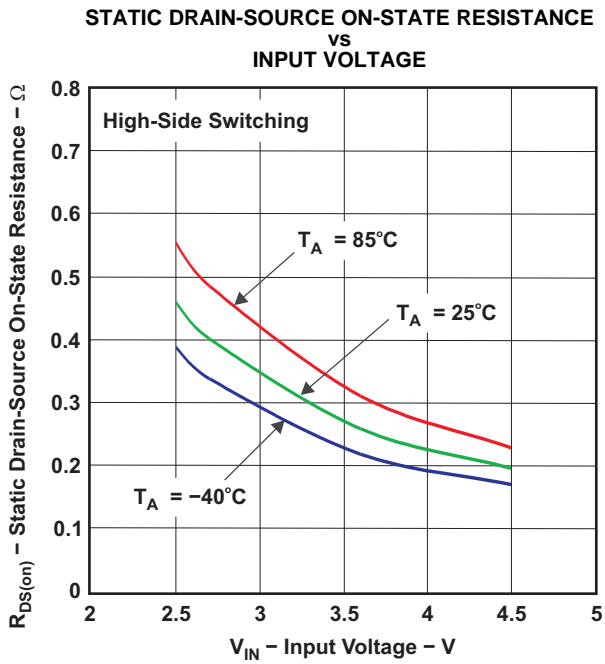

Figure 26.

G012

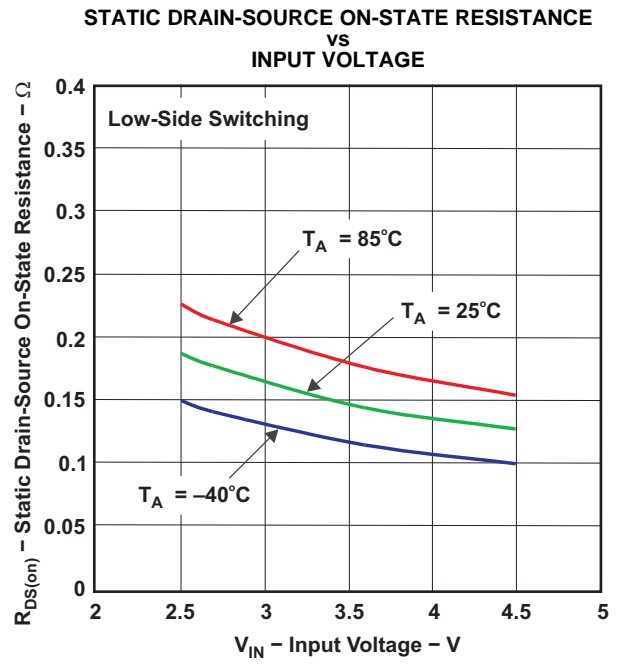

Figure 27.

## DETAILED DESCRIPTION

### OPERATION

The TPS62560/62 step-down converters operate with typically 2.25-MHz fixed-frequency pulse-width modulation (PWM) at moderate to heavy load currents. At light load currents, the converter can automatically enter power-save mode, and then operates in PFM mode. However, the TPS62561 operates with fixed-frequency PWM only, and also at light load conditions.

During PWM operation, the converter uses a unique fast-response voltage-mode control scheme with input-voltage feed-forward to achieve good line and load regulation, allowing the use of small ceramic input and output capacitors. At the beginning of each clock cycle initiated by the clock signal, the high-side MOSFET switch is turned on. The current flows from the input capacitor via the high-side MOSFET switch through the inductor to the output capacitor and load. During this phase, the current ramps up until the PWM comparator trips and the control logic turns off the switch. The current-limit comparator also turns off the switch in case the current limit of the high-side MOSFET switch is exceeded. After a dead time, which prevents shoot-through current, the low-side MOSFET rectifier is turned on and the inductor current ramps down. The current flows from the inductor to the output capacitor and to the load. It returns back to the inductor through the low-side MOSFET rectifier.

The next cycle is initiated by the clock signal again turning off the low-side MOSFET rectifier and turning on the on the high-side MOSFET switch.

### POWER-SAVE MODE

The power-save mode is enabled with the MODE terminal set to the low level. If the load current decreases, the converter enters the power-save mode of operation automatically. During power-save mode, the converter skips switching and operates with reduced frequency in PFM mode with a minimum quiescent current to maintain high efficiency. The converter positions the output voltage typically 1% above the nominal output voltage. This voltage positioning feature minimizes voltage drops caused by a sudden load step.

The transition from PWM mode to PFM mode occurs once the inductor current in the low-side MOSFET switch becomes zero, which indicates discontinuous conduction mode.

During the power-save mode, the output voltage is monitored with a PFM comparator. As the output voltage falls below the PFM comparator threshold of  $V_{OUT}$  nominal + 1%, the device starts a PFM current pulse. The high-side MOSFET switch turns on, and the inductor current ramps up. After the on-time expires, the switch is turned off and the low-side MOSFET switch is turned on until the inductor current becomes zero.

The converter effectively delivers a current to the output capacitor and the load. If the load is below the delivered current, the output voltage rises. If the output voltage is equal to or higher than the PFM comparator threshold, the device stops switching and enters a sleep mode with typical 15- $\mu$ A current consumption.

If the output voltage is still below the PFM comparator threshold, a sequence of further PFM current pulses is generated until the PFM comparator threshold is reached. The converter starts switching again once the output voltage drops below the PFM comparator threshold.

With a fast single-threshold comparator, the output-voltage ripple during PFM-mode operation can be kept small. The PFM pulse is time controlled, which allows modifying the charge transferred to the output capacitor by the value of the inductor. The resulting PFM output-voltage ripple and PFM frequency depend primarily on the size of the output capacitor and the inductor value. Increasing output capacitor values and inductor values minimizes the output ripple. The PFM frequency decreases with smaller inductor values and increases with larger values.

The PFM mode is left and PWM mode entered in case the output current can no longer be supported in PFM mode. The power-save mode can be disabled by setting the MODE terminal to high. The converter then operates in the fixed-frequency PWM mode.

### Dynamic Voltage Positioning

This feature reduces the voltage under/overshoots at load steps from light to heavy load and vice versa. It is active in power-save mode and regulates the output voltage 1% higher than the nominal value. This provides more headroom for both the voltage drop at a load step, and the voltage increase at a load throw-off.

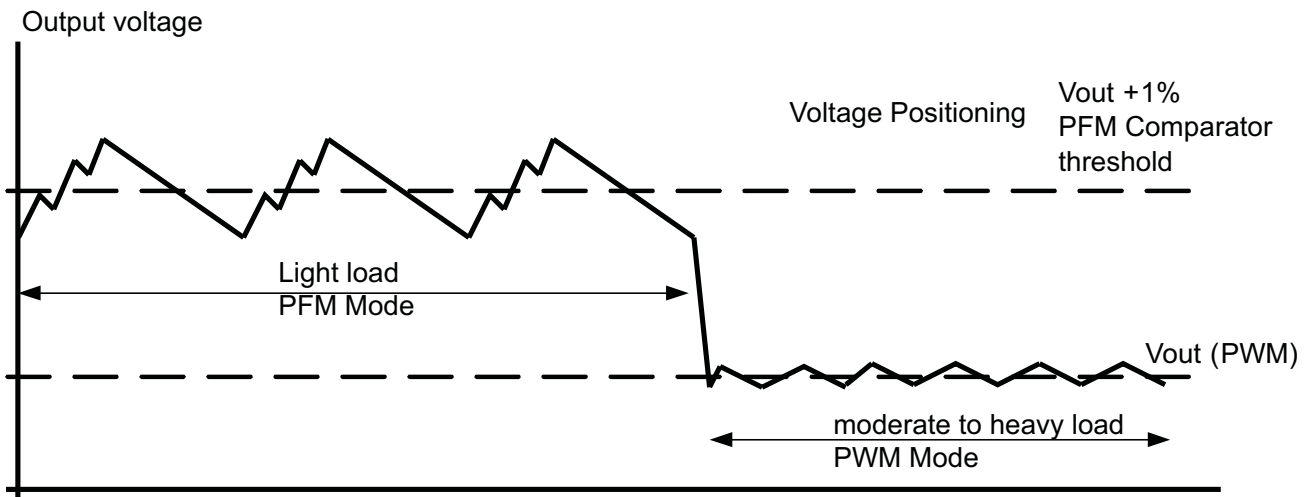

Figure 28. Power Save Mode Operation With Automatic Mode Transition

### 100% Duty-Cycle Low-Dropout Operation

The device starts to enter 100% duty-cycle mode once the input voltage comes close to the nominal output voltage. In order to maintain the output voltage, the high-side MOSFET switch is turned on 100% for one or more cycles.

With further decreasing  $V_{IN}$ , the high-side MOSFET switch is turned on completely. In this case, the converter offers a low input-to-output voltage difference. This is particularly useful in battery-powered applications to achieve longest operation time by taking full advantage of the whole battery-voltage range.

The minimum input voltage to maintain regulation depends on the load current and output voltage, and can be calculated as:

$$V_{INmin} = V_{OUTmax} + I_{OUTmax} \times (R_{DS(on)}max + R_L)$$

with:

$I_{OUTmax}$  = maximum output current plus inductor ripple current

$R_{DS(on)}max$  = maximum P-channel switch  $R_{DS(on)}$

$R_L$  = dc resistance of the inductor

$V_{OUTmax}$  = nominal output voltage plus maximum output voltage tolerance

### Undervoltage Lockout

The undervoltage lockout circuit prevents the device from malfunctioning at low input voltages and from excessive discharge of the battery and disables the output stage of the converter. The undervoltage lockout threshold is typically 1.85 V with falling  $V_{IN}$ .

### MODE SELECTION

The MODE terminal allows mode selection between forced-PWM mode and power-save mode.

Connecting this terminal to GND enables the power-save mode with automatic transition between PWM and PFM modes. Pulling the MODE terminal high forces the converter to operate in fixed-frequency PWM mode even at light load currents. This allows simple filtering of the switching frequency for noise-sensitive applications. In this mode, the efficiency is lower compared to the power-save mode during light loads.

The state of the MODE terminal can be changed during operation to allow efficient power management by adjusting the operation mode of the converter to the specific system requirements.

## **ENABLE**

The device is enabled by setting the EN terminal to high. During the start-up time  $t_{\text{Start Up}}$ , the internal circuits are settled and the soft-start circuit is activated. The EN input can be used to control power sequencing in a system with various dc/dc converters. The EN terminal can be connected to the output of another converter, to drive the EN terminal high to achieve a sequencing of the given supply rails. With EN = GND, the device enters shutdown mode, in which all internal circuits are disabled. In fixed-output-voltage versions, the internal resistor divider network is then disconnected from the FB terminal.

## **SOFT START**

The TPS62560 has an internal soft-start circuit that controls the ramp-up of the output voltage. The output voltage ramps up from 5% to 95% of its nominal value typically within 250  $\mu\text{s}$ . This limits the inrush current into the converter during ramp-up and prevents possible input voltage drops when a battery or high-impedance power source is used. The soft-start circuit is enabled within the start-up time  $t_{\text{Start Up}}$ .

## **SHORT-CIRCUIT PROTECTION**

The high-side and low-side MOSFET switches are short-circuit protected with maximum switch current =  $I_{\text{LIMF}}$ . The current in the switches is monitored by current-limit comparators. Once the current in the high-side MOSFET switch exceeds the threshold of its current-limit comparator, it turns off and the low-side MOSFET switch is activated to ramp down the current in the inductor and high-side MOSFET switch. The high-side MOSFET switch can only turn on again after the current in the low-side MOSFET switch has decreased below the threshold of its current-limit comparator.

## **THERMAL SHUTDOWN**

As soon as the junction temperature,  $T_j$ , exceeds 140°C (typical), the device goes into thermal shutdown. In this mode, the high-side and low-side MOSFETs are turned off. The device continues its operation when the junction temperature falls below the thermal shutdown hysteresis.



APPLICATION INFORMATION

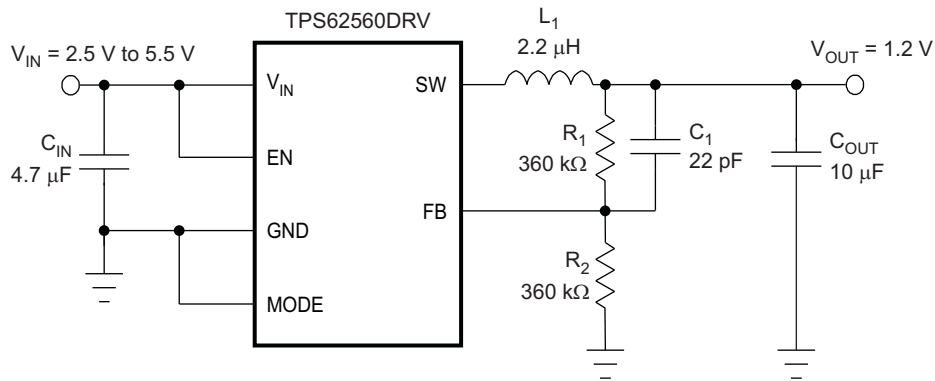

S0364\_01

Figure 29. TPS62560 Adjustable 1.2-V Output

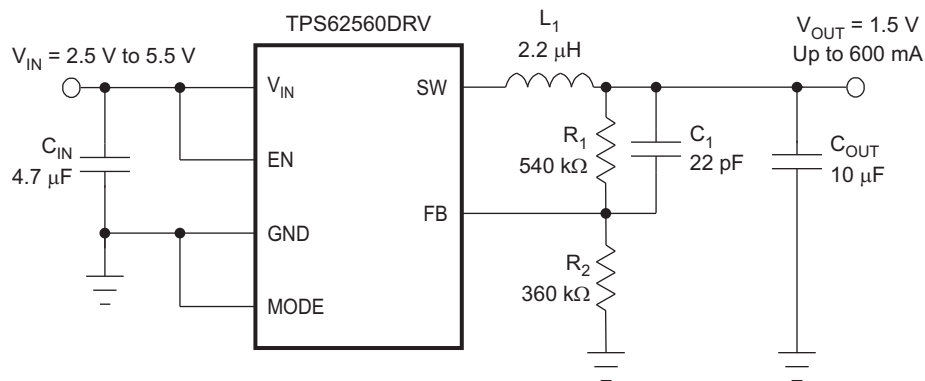

S0365-01

Figure 30. TPS62560 Adjustable 1.5-V Output

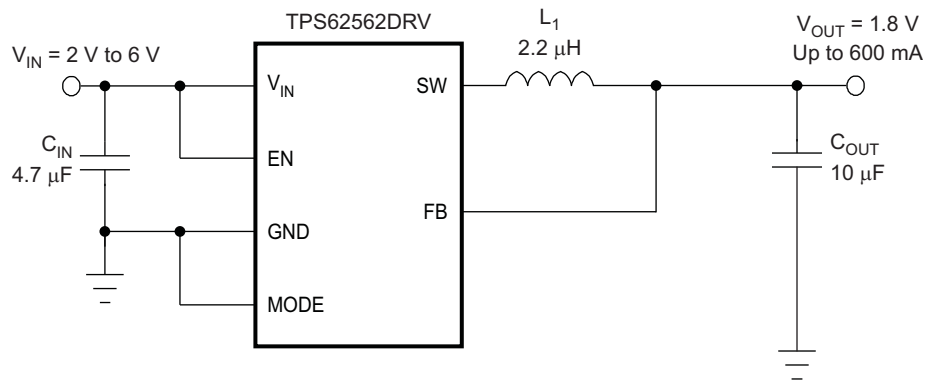

S0366-01

Figure 31. TPS62562 Fixed 1.8-V Output

## OUTPUT VOLTAGE SETTING

For adjustable output voltage versions, the output voltage can be calculated as:

$$V_{OUT} = V_{REF} \times \left( 1 + \frac{R_1}{R_2} \right) \text{ with an internal reference voltage } V_{REF}, \text{ typically } 0.6 \text{ V.}$$

To minimize the current through the feedback divider network,  $R_2$  should be 180 k $\Omega$  or 360 k $\Omega$ . The sum of  $R_1$  and  $R_2$  should not exceed ~1 M $\Omega$ , to keep the network robust against noise. An external feedforward capacitor,  $C_1$ , is required for optimum load transient response. The value of  $C_1$  should be in the range between 22 pF and 33 pF.

Route the FB line away from noise sources, such as the inductor or the SW line.

## OUTPUT FILTER DESIGN (INDUCTOR AND OUTPUT CAPACITOR)

The TPS62560 is designed to operate with inductors in the range of 1.5  $\mu$ H to 4.7  $\mu$ H and with output capacitors in the range of 4.7  $\mu$ F to 22  $\mu$ F. The part is optimized for operation with a 2.2- $\mu$ H inductor and 10- $\mu$ F output capacitor.

Larger or smaller inductor values can be used to optimize the performance of the device for specific operation conditions. For stable operation, the L and C values of the output filter may not fall below 1  $\mu$ H effective inductance and 3.5  $\mu$ F effective capacitance.

### Inductor Selection

The inductor value has a direct effect on the ripple current. The selected inductor must be rated for its dc resistance and saturation current. The inductor ripple current ( $\Delta I_L$ ) decreases with higher inductance and increases with higher  $V_{IN}$  or  $V_{OUT}$ .

The inductor selection also impacts the output voltage ripple in PFM mode. Higher inductor values lead to lower output voltage ripple and higher PFM frequency; lower inductor values lead to a higher output voltage ripple but lower PFM frequency.

[Equation 1](#) calculates the maximum inductor current in PWM mode under static load conditions. The saturation current of the inductor should be rated higher than the maximum inductor current as calculated with [Equation 2](#). This is recommended because during heavy load transients the inductor current rises above the calculated value.

$$\Delta I_L = V_{OUT} \times \frac{1 - \frac{V_{OUT}}{V_{IN}}}{L \times f} \tag{1}$$

$$I_{L \text{ max}} = I_{out \text{ max}} + \frac{\Delta I_L}{2} \tag{2}$$

where:

f = Switching frequency (2.25 MHz, typical)

L = Inductor value

$\Delta I_L$  = Peak-to-peak inductor ripple current

$I_{L \text{ max}}$  = Maximum inductor current

**Table 1. List of Inductors**

DIMENSIONS, mm	INDUCTANCE, $\mu$ H	INDUCTOR TYPE	SUPPLIER
2,5 x 2 x 1 max	2	MIPS2520D2R2	FDK
2,5 x 2 x 1,2 max	2	MIPSA2520D2R2	FDK
2,5 x 2 x 1 max	2.2	KSLI-252010AG2R2	Htachi Metals
2,5 x 2 x 1,2 max	2.2	LQM2HPN2R2MJ0L	Murata
3 x 3 x 1,5 max	2.2	LPS3015 2R2	Coilcraft

A more conservative approach is to select the inductor current rating just for the switch current limit  $I_{LIMF}$  of the converter.

Accepting larger values of ripple current allows the use of lower inductance values, but results in higher output voltage ripple, greater core losses, and lower output current capability.

The total losses of the coil have a strong impact on the efficiency of the dc/dc conversion and consist of both the losses in the dc resistance ( $R_{(DC)}$ ) and the following frequency-dependent components:

- The losses in the core material (magnetic hysteresis loss, especially at high switching frequencies)
- Additional losses in the conductor from the skin effect (current displacement at high frequencies)
- Magnetic field losses of the neighboring windings (proximity effect)
- Radiation losses

### Output Capacitor Selection

The advanced fast-response voltage-mode control scheme of the TPS62560 allows the use of tiny ceramic capacitors. Ceramic capacitors with low ESR values have the lowest output voltage ripple and are recommended. The output capacitor requires either an X7R or X5R dielectric. Y5V and Z5U dielectric capacitors, aside from their wide variation in capacitance over temperature, become resistive at high frequencies.

At nominal load current, the device operates in PWM mode, and the RMS ripple current is calculated as:

$$I_{RMS_{OUT}} = V_{OUT} \times \frac{1 - \frac{V_{OUT}}{V_{IN}}}{L \times f} \times \frac{1}{2\sqrt{3}} \quad (3)$$

At nominal load current, the device operates in PWM mode, and the overall output voltage ripple is the sum of the voltage spike caused by the output capacitor ESR plus the voltage ripple caused by charging and discharging the output capacitor:

$$\Delta V_{OUT} = V_{OUT} \times \frac{1 - \frac{V_{OUT}}{V_{IN}}}{L \times f} \times \left( \frac{1}{8 \times C_{OUT} \times f} + ESR \right) \quad (4)$$

At light load currents, the converter operates in power-save mode, and the output voltage ripple is dependent on the output capacitor and inductor values. Larger output capacitor and inductor values minimize the voltage ripple in PFM mode and tighten dc output accuracy in PFM mode.

### Input Capacitor Selection

An input capacitor is required for best input voltage filtering and minimizing the interference with other circuits caused by high input voltage spikes. For most applications, a 4.7- $\mu$ F to 10- $\mu$ F ceramic capacitor is recommended. Because a ceramic capacitor loses up to 80% of its initial capacitance at 5 V, it is recommended that 10- $\mu$ F input capacitors be used for input voltages > 4.5 V. The input capacitor can be increased without any limit for better input voltage filtering. Take care when using only small ceramic input capacitors. When a ceramic capacitor is used at the input and the power is being supplied through long wires, such as from a wall adapter, a load step at the output or  $V_{IN}$  step on the input can induce ringing at the  $V_{IN}$  terminal. This ringing can couple to the output and be mistaken as loop instability or could even damage the part by exceeding the maximum ratings.

**Table 2. List of Capacitors**

CAPACITANCE	TYPE	SIZE	SUPPLIER
4.7 $\mu$ F	GRM188R60J475K	0603—1,6 × 0,8 × 0,8 mm	Murata
10 $\mu$ F	GRM188R60J106M69D	0603—1,6 × 0,8 × 0,8 mm	Murata

## LAYOUT CONSIDERATIONS

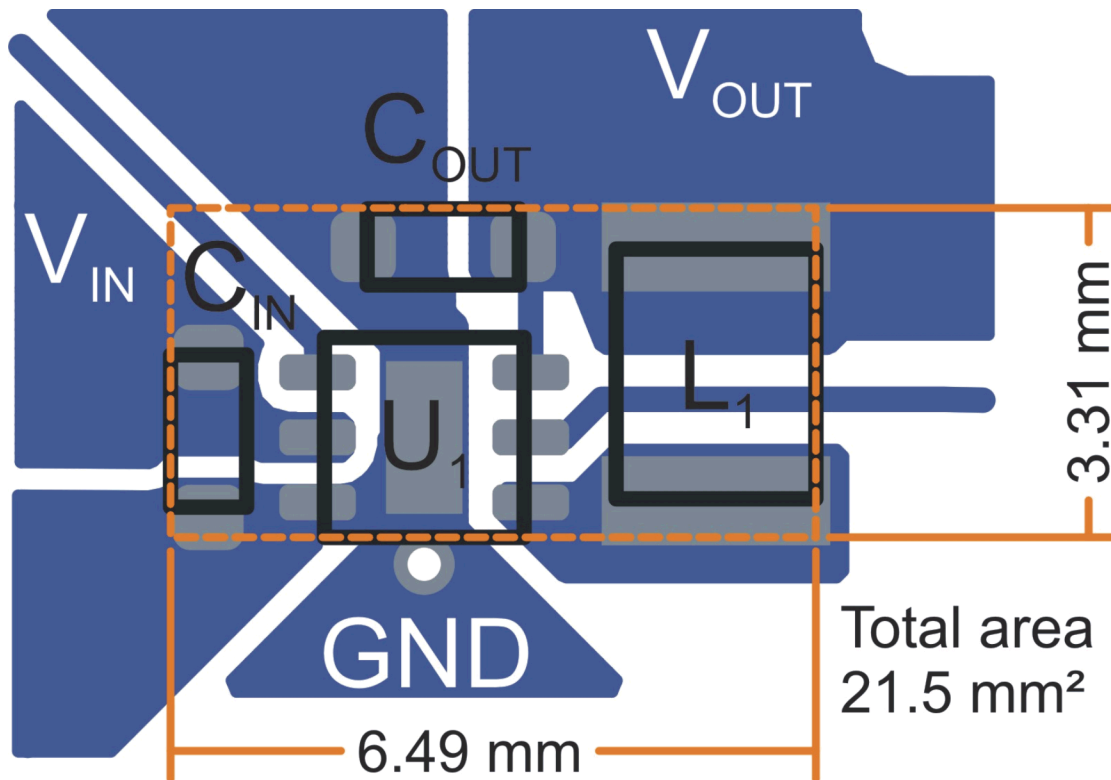
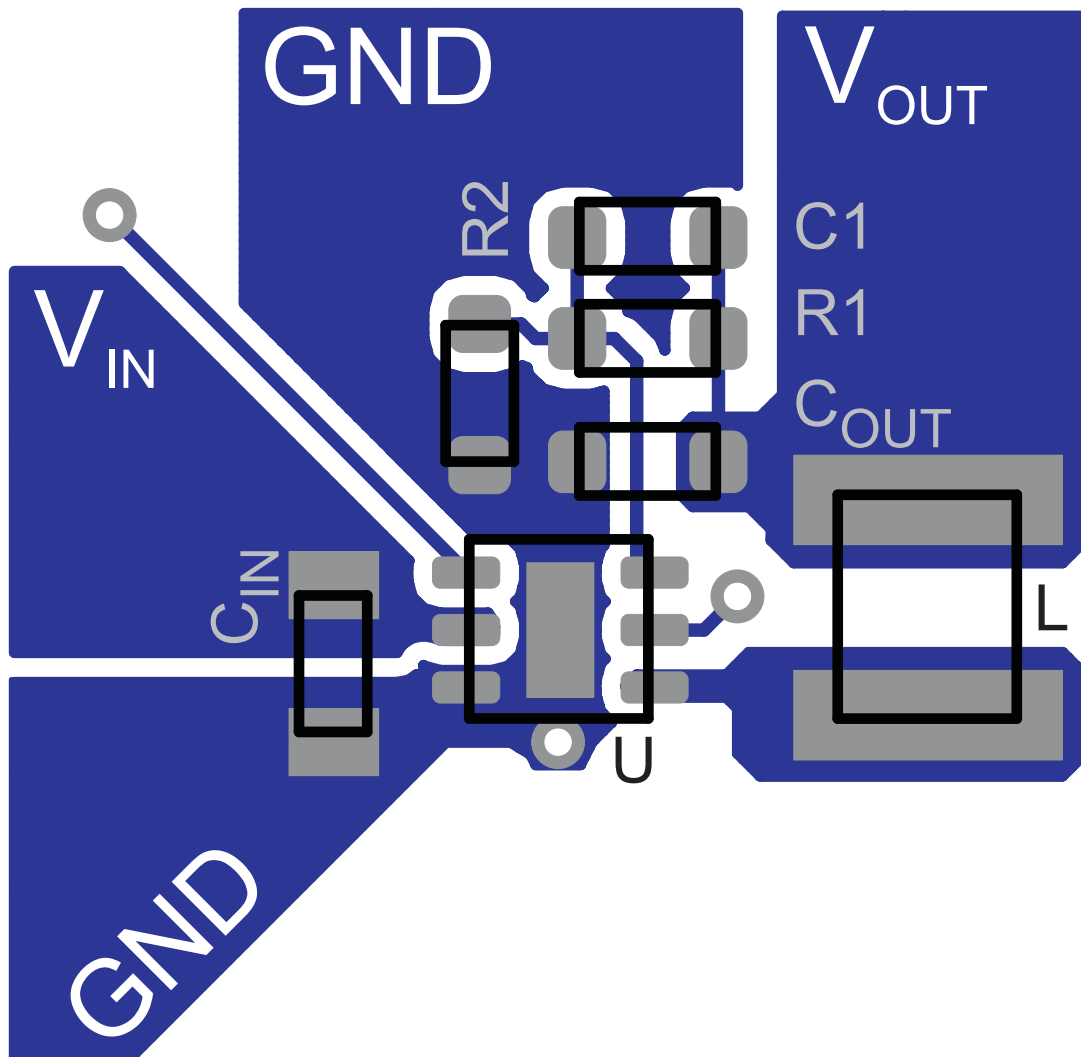

Figure 32. Suggested Layout for Fixed-Output-Voltage Options



**Figure 33. Suggested Layout for Adjustable-Output-Voltage Version**

As for all switching power supplies, the layout is an important step in the design. Proper function of the device demands careful attention to PCB layout. Care must be taken in board layout to get the specified performance. If the layout is not carefully done, the regulator could show poor line and/or load regulation and stability issues, as well as EMI problems. It is critical to provide a low-inductance, low-impedance ground path. Therefore, use wide and short traces for the main current paths. The input capacitor, inductor, and output capacitor should be placed as close as possible to the IC terminals.

Connect the GND terminal of the device to the thermal-pad land of the PCB and use this pad as a star point. Use a common power-GND node and a different node for the signal GND to minimize the effects of ground noise. Connect these ground nodes together to the thermal-pad land (star point) underneath the IC. Keep the common path to the GND terminal, which returns the small signal components and the high current of the output capacitors, as short as possible to avoid ground noise. The FB line should be connected directly to the output capacitor and routed away from noisy components and traces (e.g., the SW line).

**PACKAGING INFORMATION**

Orderable Device	Status <sup>(1)</sup>	Package Type	Package Drawing	Pins	Package Qty	Eco Plan <sup>(2)</sup>	Lead/Ball Finish	MSL Peak Temp <sup>(3)</sup>
TPS62560DRVR	ACTIVE	SON	DRV	6	3000	Green (RoHS & no Sb/Br)	CU NIPDAU	Level-2-260C-1 YEAR
TPS62560DRVRG4	ACTIVE	SON	DRV	6	3000	Green (RoHS & no Sb/Br)	CU NIPDAU	Level-2-260C-1 YEAR
TPS62560DRVT	ACTIVE	SON	DRV	6	250	Green (RoHS & no Sb/Br)	CU NIPDAU	Level-2-260C-1 YEAR
TPS62560DRVTG4	ACTIVE	SON	DRV	6	250	Green (RoHS & no Sb/Br)	CU NIPDAU	Level-2-260C-1 YEAR
TPS62561DDCR	ACTIVE	SOT	DDC	5	3000	Green (RoHS & no Sb/Br)	CU NIPDAU	Level-1-260C-UNLIM
TPS62561DDCT	ACTIVE	SOT	DDC	5	250	Green (RoHS & no Sb/Br)	CU NIPDAU	Level-1-260C-UNLIM
TPS62562DRVR	ACTIVE	SON	DRV	6	3000	Green (RoHS & no Sb/Br)	CU NIPDAU	Level-1-260C-UNLIM
TPS62562DRVT	ACTIVE	SON	DRV	6	250	Green (RoHS & no Sb/Br)	CU NIPDAU	Level-1-260C-UNLIM

<sup>(1)</sup> The marketing status values are defined as follows:

**ACTIVE:** Product device recommended for new designs.

**LIFEBUY:** TI has announced that the device will be discontinued, and a lifetime-buy period is in effect.

**NRND:** Not recommended for new designs. Device is in production to support existing customers, but TI does not recommend using this part in a new design.

**PREVIEW:** Device has been announced but is not in production. Samples may or may not be available.

**OBSOLETE:** TI has discontinued the production of the device.

<sup>(2)</sup> Eco Plan - The planned eco-friendly classification: Pb-Free (RoHS), Pb-Free (RoHS Exempt), or Green (RoHS & no Sb/Br) - please check <http://www.ti.com/productcontent> for the latest availability information and additional product content details.

**TBD:** The Pb-Free/Green conversion plan has not been defined.

**Pb-Free (RoHS):** TI's terms "Lead-Free" or "Pb-Free" mean semiconductor products that are compatible with the current RoHS requirements for all 6 substances, including the requirement that lead not exceed 0.1% by weight in homogeneous materials. Where designed to be soldered at high temperatures, TI Pb-Free products are suitable for use in specified lead-free processes.

**Pb-Free (RoHS Exempt):** This component has a RoHS exemption for either 1) lead-based flip-chip solder bumps used between the die and package, or 2) lead-based die adhesive used between the die and leadframe. The component is otherwise considered Pb-Free (RoHS compatible) as defined above.

**Green (RoHS & no Sb/Br):** TI defines "Green" to mean Pb-Free (RoHS compatible), and free of Bromine (Br) and Antimony (Sb) based flame retardants (Br or Sb do not exceed 0.1% by weight in homogeneous material)

<sup>(3)</sup> MSL, Peak Temp. -- The Moisture Sensitivity Level rating according to the JEDEC industry standard classifications, and peak solder temperature.

**Important Information and Disclaimer:**The information provided on this page represents TI's knowledge and belief as of the date that it is provided. TI bases its knowledge and belief on information provided by third parties, and makes no representation or warranty as to the accuracy of such information. Efforts are underway to better integrate information from third parties. TI has taken and continues to take reasonable steps to provide representative and accurate information but may not have conducted destructive testing or chemical analysis on incoming materials and chemicals. TI and TI suppliers consider certain information to be proprietary, and thus CAS numbers and other limited information may not be available for release.

In no event shall TI's liability arising out of such information exceed the total purchase price of the TI part(s) at issue in this document sold by TI to Customer on an annual basis.

**TAPE AND REEL INFORMATION**



**QUADRANT ASSIGNMENTS FOR PIN 1 ORIENTATION IN TAPE**



\*All dimensions are nominal

Device	Package Type	Package Drawing	Pins	SPQ	Reel Diameter (mm)	Reel Width W1 (mm)	A0 (mm)	B0 (mm)	K0 (mm)	P1 (mm)	W (mm)	Pin1 Quadrant
TPS62560DRVR	SON	DRV	6	3000	179.0	8.4	2.2	2.2	1.2	4.0	8.0	Q2
TPS62560DRVT	SON	DRV	6	250	179.0	8.4	2.2	2.2	1.2	4.0	8.0	Q2
TPS62561DDCR	SOT	DDC	5	3000	179.0	8.4	3.2	3.2	1.4	4.0	8.0	Q3
TPS62561DDCT	SOT	DDC	5	250	179.0	8.4	3.2	3.2	1.4	4.0	8.0	Q3
TPS62562DRVR	SON	DRV	6	3000	179.0	8.4	2.2	2.2	1.2	4.0	8.0	Q2
TPS62562DRVT	SON	DRV	6	250	179.0	8.4	2.2	2.2	1.2	4.0	8.0	Q2

**TAPE AND REEL BOX DIMENSIONS**



\*All dimensions are nominal

Device	Package Type	Package Drawing	Pins	SPQ	Length (mm)	Width (mm)	Height (mm)
TPS62560DRVR	SON	DRV	6	3000	195.0	200.0	45.0
TPS62560DRVT	SON	DRV	6	250	195.0	200.0	45.0
TPS62561DDCR	SOT	DDC	5	3000	195.0	200.0	45.0
TPS62561DDCT	SOT	DDC	5	250	195.0	200.0	45.0
TPS62562DRVR	SON	DRV	6	3000	195.0	200.0	45.0
TPS62562DRVT	SON	DRV	6	250	195.0	200.0	45.0



## DDC (R-PDSO-G5)

## PLASTIC SMALL-OUTLINE

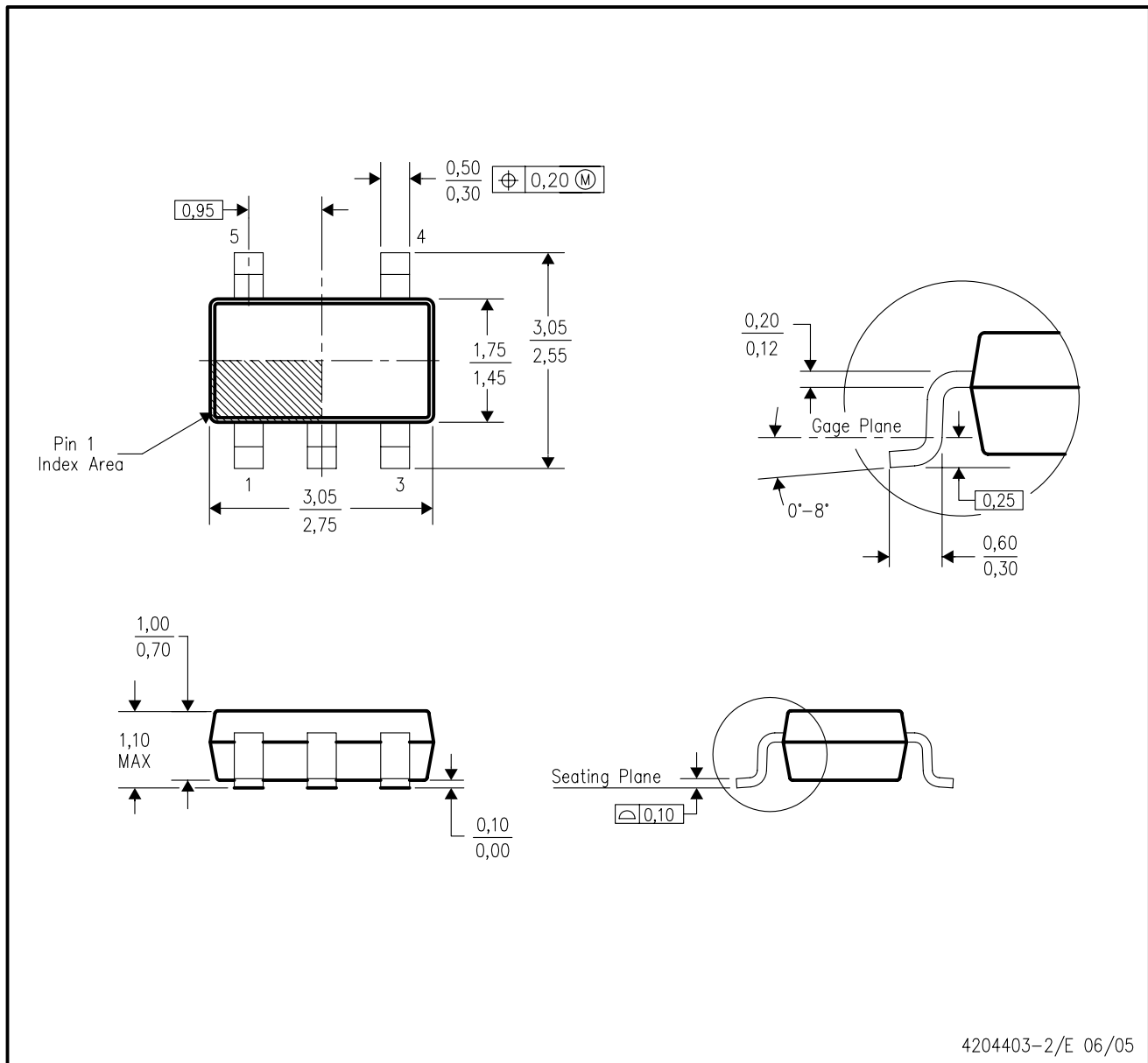

- NOTES:
- All linear dimensions are in millimeters.
  - This drawing is subject to change without notice.
  - Body dimensions do not include mold flash or protrusion.
  - Falls within JEDEC MO-193 variation AB (5 pin).

DRV (S-PDSO-N6)

PLASTIC SMALL OUTLINE

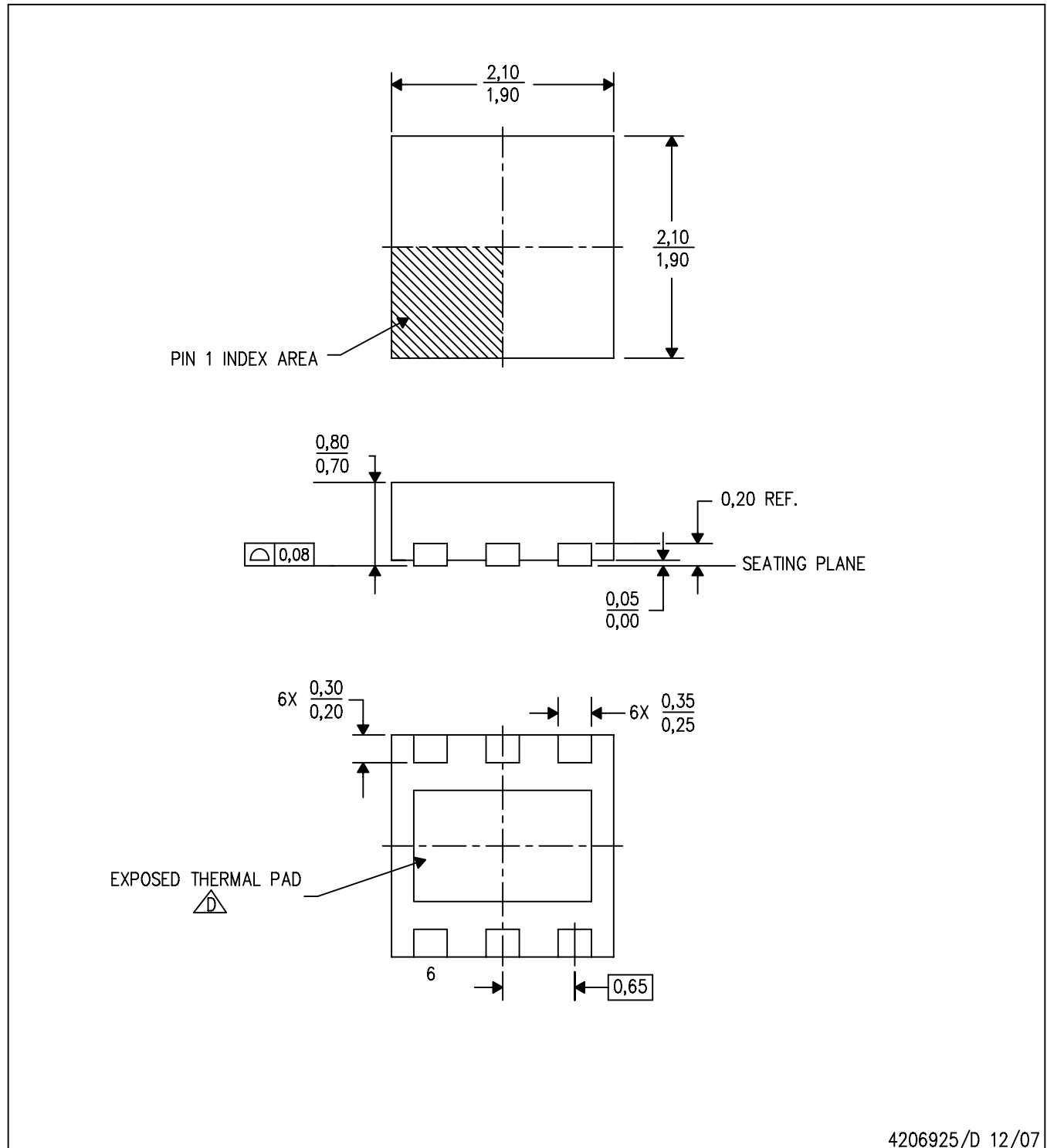

4206925/D 12/07

- NOTES:
- A. All linear dimensions are in millimeters. Dimensioning and tolerancing per ASME Y14.5M-1994.
  - B. This drawing is subject to change without notice.
  - C. Small Outline No-Lead (SON) package configuration.
-  The package thermal pad must be soldered to the board for thermal and mechanical performance. See the Product Data Sheet for details regarding the exposed thermal pad dimensions.

**THERMAL INFORMATION**

This package incorporates an exposed thermal pad that is designed to be attached directly to an external heatsink. The thermal pad must be soldered directly to the printed circuit board (PCB). After soldering, the PCB can be used as a heatsink. In addition, through the use of thermal vias, the thermal pad can be attached directly to the appropriate copper plane shown in the electrical schematic for the device, or alternatively, can be attached to a special heatsink structure designed into the PCB. This design optimizes the heat transfer from the integrated circuit (IC).

For information on the Quad Flatpack No-Lead (QFN) package and its advantages, refer to Application Report, Quad Flatpack No-Lead Logic Packages, Texas Instruments Literature No. SCBA017. This document is available at [www.ti.com](http://www.ti.com).

The exposed thermal pad dimensions for this package are shown in the following illustration.

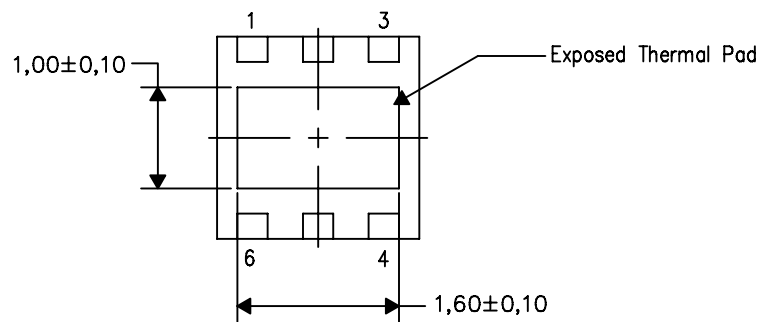

Bottom View

NOTE: All linear dimensions are in millimeters

Exposed Thermal Pad Dimensions

## DRV (S-PDSO-N6)

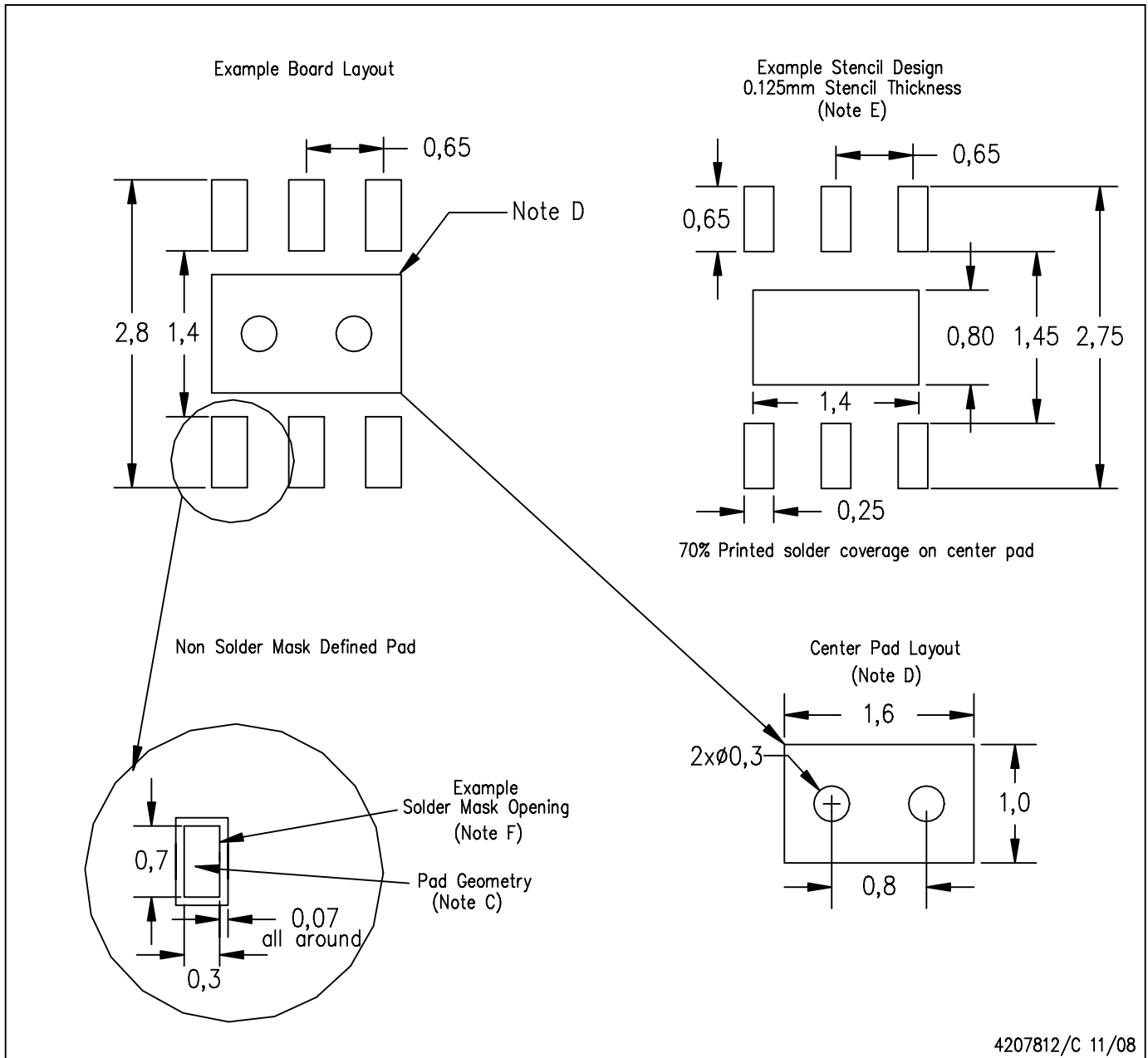

- NOTES:
- All linear dimensions are in millimeters.
  - This drawing is subject to change without notice.
  - Publication IPC-7351 is recommended for alternate designs.
  - This package is designed to be soldered to a thermal pad on the board. Refer to Application Note, QFN Packages, Texas Instruments Literature No. SCBA017, SLUA271, and also the Product Data Sheets for specific thermal information, via requirements, and recommended board layout. These documents are available at [www.ti.com](http://www.ti.com) <<http://www.ti.com>>.
  - Laser cutting apertures with trapezoidal walls and also rounding corners will offer better paste release. Customers should contact their board assembly site for stencil design recommendations. Refer to IPC 7525 for stencil design considerations.
  - Customers should contact their board fabrication site for solder mask tolerances.

## IMPORTANT NOTICE

Texas Instruments Incorporated and its subsidiaries (TI) reserve the right to make corrections, modifications, enhancements, improvements, and other changes to its products and services at any time and to discontinue any product or service without notice. Customers should obtain the latest relevant information before placing orders and should verify that such information is current and complete. All products are sold subject to TI's terms and conditions of sale supplied at the time of order acknowledgment.

TI warrants performance of its hardware products to the specifications applicable at the time of sale in accordance with TI's standard warranty. Testing and other quality control techniques are used to the extent TI deems necessary to support this warranty. Except where mandated by government requirements, testing of all parameters of each product is not necessarily performed.

TI assumes no liability for applications assistance or customer product design. Customers are responsible for their products and applications using TI components. To minimize the risks associated with customer products and applications, customers should provide adequate design and operating safeguards.

TI does not warrant or represent that any license, either express or implied, is granted under any TI patent right, copyright, mask work right, or other TI intellectual property right relating to any combination, machine, or process in which TI products or services are used. Information published by TI regarding third-party products or services does not constitute a license from TI to use such products or services or a warranty or endorsement thereof. Use of such information may require a license from a third party under the patents or other intellectual property of the third party, or a license from TI under the patents or other intellectual property of TI.

Reproduction of TI information in TI data books or data sheets is permissible only if reproduction is without alteration and is accompanied by all associated warranties, conditions, limitations, and notices. Reproduction of this information with alteration is an unfair and deceptive business practice. TI is not responsible or liable for such altered documentation. Information of third parties may be subject to additional restrictions.

Resale of TI products or services with statements different from or beyond the parameters stated by TI for that product or service voids all express and any implied warranties for the associated TI product or service and is an unfair and deceptive business practice. TI is not responsible or liable for any such statements.

TI products are not authorized for use in safety-critical applications (such as life support) where a failure of the TI product would reasonably be expected to cause severe personal injury or death, unless officers of the parties have executed an agreement specifically governing such use. Buyers represent that they have all necessary expertise in the safety and regulatory ramifications of their applications, and acknowledge and agree that they are solely responsible for all legal, regulatory and safety-related requirements concerning their products and any use of TI products in such safety-critical applications, notwithstanding any applications-related information or support that may be provided by TI. Further, Buyers must fully indemnify TI and its representatives against any damages arising out of the use of TI products in such safety-critical applications.

TI products are neither designed nor intended for use in military/aerospace applications or environments unless the TI products are specifically designated by TI as military-grade or "enhanced plastic." Only products designated by TI as military-grade meet military specifications. Buyers acknowledge and agree that any such use of TI products which TI has not designated as military-grade is solely at the Buyer's risk, and that they are solely responsible for compliance with all legal and regulatory requirements in connection with such use.

TI products are neither designed nor intended for use in automotive applications or environments unless the specific TI products are designated by TI as compliant with ISO/TS 16949 requirements. Buyers acknowledge and agree that, if they use any non-designated products in automotive applications, TI will not be responsible for any failure to meet such requirements.

Following are URLs where you can obtain information on other Texas Instruments products and application solutions:

### Products

Amplifiers	<a href="http://amplifier.ti.com">amplifier.ti.com</a>
Data Converters	<a href="http://dataconverter.ti.com">dataconverter.ti.com</a>
DSP	<a href="http://dsp.ti.com">dsp.ti.com</a>
Clocks and Timers	<a href="http://www.ti.com/clocks">www.ti.com/clocks</a>
Interface	<a href="http://interface.ti.com">interface.ti.com</a>
Logic	<a href="http://logic.ti.com">logic.ti.com</a>
Power Mgmt	<a href="http://power.ti.com">power.ti.com</a>
Microcontrollers	<a href="http://microcontroller.ti.com">microcontroller.ti.com</a>
RFID	<a href="http://www.ti-rfid.com">www.ti-rfid.com</a>
RF/IF and ZigBee® Solutions	<a href="http://www.ti.com/lprf">www.ti.com/lprf</a>

### Applications

Audio	<a href="http://www.ti.com/audio">www.ti.com/audio</a>
Automotive	<a href="http://www.ti.com/automotive">www.ti.com/automotive</a>
Broadband	<a href="http://www.ti.com/broadband">www.ti.com/broadband</a>
Digital Control	<a href="http://www.ti.com/digitalcontrol">www.ti.com/digitalcontrol</a>
Medical	<a href="http://www.ti.com/medical">www.ti.com/medical</a>
Military	<a href="http://www.ti.com/military">www.ti.com/military</a>
Optical Networking	<a href="http://www.ti.com/opticalnetwork">www.ti.com/opticalnetwork</a>
Security	<a href="http://www.ti.com/security">www.ti.com/security</a>
Telephony	<a href="http://www.ti.com/telephony">www.ti.com/telephony</a>
Video & Imaging	<a href="http://www.ti.com/video">www.ti.com/video</a>
Wireless	<a href="http://www.ti.com/wireless">www.ti.com/wireless</a>

Mailing Address: Texas Instruments, Post Office Box 655303, Dallas, Texas 75265  
Copyright © 2008, Texas Instruments Incorporated