

## Complete DDR2, DDR3 and DDR3L Memory Power Solution Synchronous Buck Controller, 2-A LDO, Buffered Reference

### FEATURES

- **Synchronous Buck Controller (VDDQ)**
  - Conversion Voltage Range: 3 V to 28 V
  - Output Voltage Range: 0.7 V to 1.8 V
  - 0.8%  $V_{REF}$  Accuracy
  - Selectable Control Architecture
    - D-CAP™ Mode for Fast Transient Response
    - D-CAP2™ Mode for Ceramic Output Capacitors
  - Selectable 300 kHz/ 400 kHz/ 500 kHz/ 670 kHz Switching Frequencies
  - Optimized Efficiency at Light and Heavy Loads with Auto-skip Function
  - Supports Soft-Off in S4/S5 States
  - OCL/OVP/UVP/UVLO Protections
  - Powergood Output
- **2-A LDO(VTT), Buffered Reference(VTTREF)**
  - 2-A (Peak) Sink and Source Current
  - Requires Only 10- $\mu$ F of Ceramic Output Capacitance
  - Buffered, Low Noise, 10-mA VTTREF Output
  - 0.8% VTTREF, 20-mV VTT Accuracy
  - Support High-Z in S3 and Soft-Off in S4/S5
- Thermal Shutdown
- 20-Pin, 3 mm x 3 mm, QFN Package

### APPLICATIONS

- DDR2/DDR3/DDR3L Memory Power Supplies
- SSTL\_18, SSTL\_15, SSTL\_135 and HSTL Termination

### DESCRIPTION

The TPS51916 provides a complete power supply for DDR2, DDR3 and DDR3L memory systems in the lowest total cost and minimum space. It integrates a synchronous buck regulator controller (VDDQ) with a 2-A sink/source tracking LDO (VTT) and buffered low noise reference (VTTREF). The TPS51916 employs D-CAP™ mode coupled with 300 kHz/400 kHz frequencies for ease-of-use and fast transient response or D-CAP2™ mode coupled with higher 500 kHz/670 kHz frequencies to support ceramic output capacitor without an external compensation circuit. The VTTREF tracks VDDQ/2 within excellent 0.8% accuracy. The VTT, which provides 2-A sink/source peak current capabilities, requires only 10- $\mu$ F of ceramic capacitance. In addition, a dedicated LDO supply input is available.

The TPS51916 provides rich useful functions as well as excellent power supply performance. It supports flexible power state control, placing VTT at high-Z in S3 and discharging VDDQ, VTT and VTTREF (soft-off) in S4/S5 state. Programmable OCL with low-side MOSFET  $R_{DS(on)}$  sensing, OVP/UVP/UVLO and thermal shutdown protections are also available.

The TPS51916 is available in a 20-pin, 3 mm x 3 mm, QFN package and is specified for ambient temperature from  $-40^{\circ}\text{C}$  to  $85^{\circ}\text{C}$ .

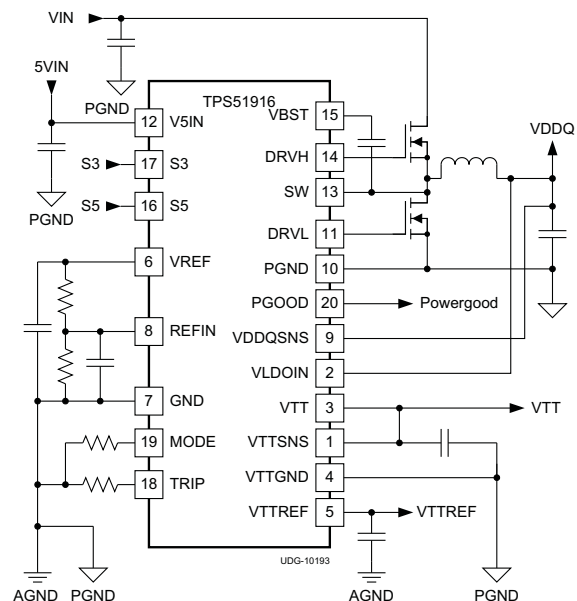

Please be aware that an important notice concerning availability, standard warranty, and use in critical applications of Texas Instruments semiconductor products and disclaimers thereto appears at the end of this data sheet.

D-CAP, D-CAP2 are trademarks of Texas Instruments.

# TPS51916

SLUSAE1D – DECEMBER 2010 – REVISED JUNE 2012

[www.ti.com](http://www.ti.com)



These devices have limited built-in ESD protection. The leads should be shorted together or the device placed in conductive foam during storage or handling to prevent electrostatic damage to the MOS gates.

## ORDERING INFORMATION<sup>(1)</sup>

T <sub>A</sub>	PACKAGE	ORDERABLE DEVICE NUMBER	PINS	OUTPUT SUPPLY	MINIMUM QUANTITY
–40°C to 85°C	Plastic Quad Flat Pack (QFN)	TPS51916RUKR	20	Tape and reel	3000
		TPS51916RUKT		Mini reel	250

(1) For the most current package and ordering information see the *Package Option Addendum* at the end of this document, or see the TI web site at [www.ti.com](http://www.ti.com).

## ABSOLUTE MAXIMUM RATINGS<sup>(1)</sup>

over operating free-air temperature range (unless otherwise noted)

		VALUE		UNIT
		MIN	MAX	
Input voltage range <sup>(2)</sup>	VBST	–0.3	36	V
	VBST <sup>(3)</sup>	–0.3	6	
	SW	–5	30	
	VLDOIN, VDDQSNS, REFIN	–0.3	3.6	
	VTTSENS	–0.3	3.6	
	PGND, VTTGND	–0.3	0.3	
	V5IN, S3, S5, TRIP, MODE	–0.3	6	
Output voltage range <sup>(2)</sup>	DRVH	–5	36	V
	DRVH <sup>(3)</sup>	–0.3	6	
	VTTREF, VREF	–0.3	3.6	
	VTT	–0.3	3.6	
	DRVL	–0.3	6	
	PGOOD	–0.3	6	
Junction temperature range, T <sub>J</sub>			125	°C
Storage temperature range, T <sub>STG</sub>		–55	150	°C

- (1) Stresses beyond those listed under absolute maximum ratings may cause permanent damage to the device. These are stress ratings only and functional operation of the device at these or any other conditions beyond those indicated under recommended operating conditions is not implied. Exposure to absolute-maximum-rated conditions for extended periods may affect device reliability.
- (2) All voltage values are with respect to the network ground terminal unless otherwise noted.
- (3) Voltage values are with respect to the SW terminal.

## THERMAL INFORMATION

THERMAL METRIC		TPS51916	UNITS
		QFN (20) PINS	
θ <sub>JA</sub>	Junction-to-ambient thermal resistance	94.1	°C/W
θ <sub>JCtop</sub>	Junction-to-case (top) thermal resistance	58.1	
θ <sub>JB</sub>	Junction-to-board thermal resistance	64.3	
ψ <sub>JT</sub>	Junction-to-top characterization parameter	31.8	
ψ <sub>JB</sub>	Junction-to-board characterization parameter	58.0	
θ <sub>JCbot</sub>	Junction-to-case (bottom) thermal resistance	5.9	

**RECOMMENDED OPERATING CONDITIONS**

		MIN	TYP	MAX	UNIT
Supply voltage	V5IN	4.5		5.5	V
Input voltage range	VBST	-0.1		33.5	V
	VBST <sup>(1)</sup>	-0.1		5.5	
	SW	-3		28	
	SW <sup>(2)</sup>	-4.5		28	
	VLDOIN, VDDQSNS, REFIN	-0.1		3.5	
	VTTSENS	-0.1		3.5	
	PGND, VTTGND	-0.1		0.1	
	S3, S5, TRIP, MODE	-0.1		5.5	
Output voltage range	DRVH	-3		33.5	V
	DRVH <sup>(1)</sup>	-0.1		5.5	
	DRVH <sup>(2)</sup>	-4.5		33.5	
	VTTREF, VREF	-0.1		3.5	
	VTT	-0.1		3.5	
	DRVL	-0.1		5.5	
	PGOOD	-0.1		5.5	
T <sub>A</sub>	Operating free-air temperature	-40		85	°C

(1) Voltage values are with respect to the SW terminal.

(2) This voltage should be applied for less than 30% of the repetitive period.

**ELECTRICAL CHARACTERISTICS**

 over operating free-air temperature range,  $V_{V5IN} = 5\text{ V}$ , VLDOIN is connected to VDDQ output,  $V_{MODE} = 0\text{ V}$ ,  $V_{S3} = V_{S5} = 5\text{ V}$  (unless otherwise noted)

PARAMETER		TEST CONDITION	MIN	TYP	MAX	UNIT
<b>SUPPLY CURRENT</b>						
$I_{V5IN(S0)}$	V5IN supply current, in S0	$T_A = 25^\circ\text{C}$ , No load, $V_{S3} = V_{S5} = 5\text{ V}$		590		$\mu\text{A}$
$I_{V5IN(S3)}$	V5IN supply current, in S3	$T_A = 25^\circ\text{C}$ , No load, $V_{S3} = 0\text{ V}$ , $V_{S5} = 5\text{ V}$		500		$\mu\text{A}$
$I_{V5INSDN}$	V5IN shutdown current	$T_A = 25^\circ\text{C}$ , No load, $V_{S3} = V_{S5} = 0\text{ V}$			1	$\mu\text{A}$
$I_{VLDOIN(S0)}$	VLDOIN supply current, in S0	$T_A = 25^\circ\text{C}$ , No load, $V_{S3} = V_{S5} = 5\text{ V}$			5	$\mu\text{A}$
$I_{VLDOIN(S3)}$	VLDOIN supply current, in S3	$T_A = 25^\circ\text{C}$ , No load, $V_{S3} = 0\text{ V}$ , $V_{S5} = 5\text{ V}$			5	$\mu\text{A}$
$I_{VLDOINSDN}$	VLDOIN shutdown current	$T_A = 25^\circ\text{C}$ , No load, $V_{S3} = V_{S5} = 0\text{ V}$			5	$\mu\text{A}$
<b>VREF OUTPUT</b>						
$V_{VREF}$	Output voltage	$I_{VREF} = 30\text{ }\mu\text{A}$ , $T_A = 25^\circ\text{C}$		1.8000		V
		$0\text{ }\mu\text{A} \leq I_{VREF} < 300\text{ }\mu\text{A}$ , $T_A = -10^\circ\text{C}$ to $85^\circ\text{C}$	1.7856		1.8144	
		$0\text{ }\mu\text{A} \leq I_{VREF} < 300\text{ }\mu\text{A}$ , $T_A = -40^\circ\text{C}$ to $85^\circ\text{C}$	1.7820		1.8180	
$I_{VREFOCL}$	Current limit	$V_{VREF} = 1.7\text{ V}$	0.4	0.8		mA
<b>VTTREF OUTPUT</b>						
$V_{VTTREF}$	Output voltage			$V_{VDDQSNS}/2$		V
$V_{VTTREF}$	Output voltage tolerance to $V_{VDDQ}$	$ I_{VTTREF}  < 100\text{ }\mu\text{A}$ , $1.2\text{ V} \leq V_{VDDQSNS} \leq 1.8\text{ V}$	49.2%		50.8%	
		$ I_{VTTREF}  < 10\text{ mA}$ , $1.2\text{ V} \leq V_{VDDQSNS} \leq 1.8\text{ V}$	49%		51%	
$I_{VTTREFOCLSRC}$	Source current limit	$V_{VDDQSNS} = 1.8\text{ V}$ , $V_{VTTREF} = 0\text{ V}$	10	18		mA
$I_{VTTREFOCLSNK}$	Sink current limit	$V_{VDDQSNS} = 1.8\text{ V}$ , $V_{VTTREF} = 1.8\text{ V}$	10	17		mA
$I_{VTTREFDIS}$	VTTREF discharge current	$T_A = 25^\circ\text{C}$ , $V_{S3} = V_{S5} = 0\text{ V}$ , $V_{VTTREF} = 0.5\text{ V}$	0.8	1.3		mA
<b>VTT OUTPUT</b>						
$V_{VTT}$	Output voltage			$V_{VTTREF}$		V
$V_{VTTTOL}$	Output voltage tolerance to VTTREF	$ I_{VTT}  \leq 10\text{ mA}$ , $1.2\text{ V} \leq V_{VDDQSNS} \leq 1.8\text{ V}$ , $I_{VTTREF} = 0\text{ A}$	-20		20	mV
		$ I_{VTT}  \leq 1\text{ A}$ , $1.2 \leq V_{VDDQSNS} \leq 1.8\text{ V}$ , $I_{VTTREF} = 0\text{ A}$	-30		30	
		$ I_{VTT}  \leq 2\text{ A}$ , $1.4\text{ V} \leq V_{VDDQSNS} \leq 1.8\text{ V}$ , $I_{VTTREF} = 0\text{ A}$	-40		40	
		$ I_{VTT}  \leq 1.5\text{ A}$ , $1.2\text{ V} \leq V_{VDDQSNS} \leq 1.4\text{ V}$ , $I_{VTTREF} = 0\text{ A}$	-40		40	
$I_{VTTOCLSRC}$	Source current limit	$V_{VDDQSNS} = 1.8\text{ V}$ , $V_{VTT} = V_{VTTNS} = 0.7\text{ V}$ , $I_{VTTREF} = 0\text{ A}$	2	3		A
$I_{VTTOCLSNK}$	Sink current limit	$V_{VDDQSNS} = 1.8\text{ V}$ , $V_{VTT} = V_{VTTNS} = 1.1\text{ V}$ , $I_{VTTREF} = 0\text{ A}$	2	3		A
$I_{VTTTLK}$	Leakage current	$T_A = 25^\circ\text{C}$ , $V_{S3} = 0\text{ V}$ , $V_{S5} = 5\text{ V}$ , $V_{VTT} = V_{VTTREF}$			5	$\mu\text{A}$
$I_{VTTNSBIAS}$	VTTNS input bias current	$V_{S3} = 5\text{ V}$ , $V_{S5} = 5\text{ V}$ , $V_{VTTNS} = V_{VTTREF}$	-0.5	0.0	0.5	$\mu\text{A}$
$I_{VTTNSLK}$	VTTNS leakage current	$V_{S3} = 0\text{ V}$ , $V_{S5} = 5\text{ V}$ , $V_{VTTNS} = V_{VTTREF}$	-1	0	1	$\mu\text{A}$
$I_{VTTDIS}$	VTT Discharge current	$T_A = 25^\circ\text{C}$ , $V_{S3} = V_{S5} = 0\text{ V}$ , $V_{VDDQSNS} = 1.8\text{ V}$ , $V_{VTT} = 0.5\text{ V}$ , $I_{VTTREF} = 0\text{ A}$		7.8		mA
<b>VDDQ OUTPUT</b>						
$V_{VDDQSNS}$	VDDQ sense voltage			$V_{REFIN}$		
$V_{VDDQSNSTOL}$	VDDQSNS regulation voltage tolerance to REFIN	$T_A = 25^\circ\text{C}$	-3		3	mV
$I_{VDDQSNS}$	VDDQSNS input current	$V_{VDDQSNS} = 1.8\text{ V}$		39		$\mu\text{A}$
$I_{REFIN}$	REFIN input current	$V_{REFIN} = 1.8\text{ V}$	-0.1	0.0	0.1	$\mu\text{A}$
$I_{VDDQDIS}$	VDDQ discharge current	$V_{S3} = V_{S5} = 0\text{ V}$ , $V_{VDDQSNS} = 0.5\text{ V}$ , MODE pin pulled down to GND through 47k $\Omega$ (Non-tracking)		12		mA
$I_{VLDOINDIS}$	VLDOIN discharge current	$V_{S3} = V_{S5} = 0\text{ V}$ , $V_{VDDQSNS} = 0.5\text{ V}$ , MODE pin pulled down to GND through 100k $\Omega$ (Non-tracking)		1.2		A
<b>SWITCH MODE POWER SUPPLY (SMPS) FREQUENCY</b>						
$f_{SW}$	VDDQ switching frequency	$V_{IN} = 12\text{ V}$ , $V_{VDDQSNS} = 1.8\text{ V}$ , $R_{MODE} = 100\text{ k}\Omega$		300		kHz
		$V_{IN} = 12\text{ V}$ , $V_{VDDQSNS} = 1.8\text{ V}$ , $R_{MODE} = 200\text{ k}\Omega$		400		
		$V_{IN} = 12\text{ V}$ , $V_{VDDQSNS} = 1.8\text{ V}$ , $R_{MODE} = 1\text{ k}\Omega$		500		
		$V_{IN} = 12\text{ V}$ , $V_{VDDQSNS} = 1.8\text{ V}$ , $R_{MODE} = 12\text{ k}\Omega$		670		
$t_{ON(min)}$	Minimum on time	DRVH rising to falling <sup>(1)</sup>		60		ns
$t_{OFF(min)}$	Minimum off time	DRVH falling to rising	200	320	450	

(1) Ensured by design. Not production tested.

**ELECTRICAL CHARACTERISTICS (continued)**

over operating free-air temperature range,  $V_{V5IN} = 5\text{ V}$ , VLDOIN is connected to VDDQ output,  $V_{MODE} = 0\text{ V}$ ,  $V_{S3} = V_{S5} = 5\text{ V}$  (unless otherwise noted)

PARAMETER		TEST CONDITION	MIN	TYP	MAX	UNIT
<b>VDDQ MOSFET DRIVER</b>						
$R_{DRVH}$	DRVH resistance	Source, $I_{DRVH} = -50\text{ mA}$		1.6	3.0	$\Omega$
		Sink, $I_{DRVH} = 50\text{ mA}$		0.6	1.5	
$R_{DRVL}$	DRVL resistance	Source, $I_{DRVL} = -50\text{ mA}$		0.9	2.0	$\Omega$
		Sink, $I_{DRVL} = 50\text{ mA}$		0.5	1.2	
$t_{DEAD}$	Dead time	DRVH-off to DRVL-on		10		ns
		DRVL-off to DRVH-on		20		
<b>INTERNAL BOOT STRAP SW</b>						
$V_{FBST}$	Forward Voltage	$V_{V5IN-VBST}$ , $T_A = 25^\circ\text{C}$ , $I_F = 10\text{ mA}$		0.1	0.2	V
$I_{VBSTLK}$	VBST leakage current	$T_A = 25^\circ\text{C}$ , $V_{VBST} = 33\text{ V}$ , $V_{SW} = 28\text{ V}$		0.01	1.5	$\mu\text{A}$
<b>LOGIC THRESHOLD</b>						
$I_{MODE}$	MODE source current		14	15	16	$\mu\text{A}$
$V_{THMODE}$	MODE threshold voltage	MODE 0-1	109	129	149	mV
		MODE 1-2	235	255	275	
		MODE 2-3	392	412	432	
		MODE 3-4	580	600	620	
		MODE 4-5	829	854	879	
		MODE 5-6	1202	1232	1262	
		MODE 6-7	1760	1800	1840	
$V_{IL}$	S3/S5 low-level voltage				0.5	V
$V_{IH}$	S3/S5 high-level voltage		1.8			
$V_{IHYST}$	S3/S5 hysteresis voltage			0.25		
$I_{ILK}$	S3/S5 input leak current		-1	0	1	$\mu\text{A}$
<b>SOFT START</b>						
$t_{SS}$	VDDQ soft-start time	Internal soft-start time, $C_{VREF} = 0.1\text{ }\mu\text{F}$ , S5 rising to $V_{VDDQSNS} > 0.99 \times V_{REFIN}$		1.1		ms
<b>PGOOD COMPARATOR</b>						
$V_{THPG}$	VDDQ PGOOD threshold	PGOOD in from higher	106%	108%	110%	
		PGOOD in from lower	90%	92%	94%	
		PGOOD out to higher	114%	116%	118%	
		PGOOD out to lower	82%	84%	86%	
$I_{PG}$	PGOOD sink current	$V_{PGOOD} = 0.5\text{ V}$	3	5.9		mA
$t_{PGDLY}$	PGOOD delay time	Delay for PGOOD in	0.8	1	1.2	ms
		Delay for PGOOD out, with 100 mV over drive		330		ns
$t_{PGSSDLY}$	PGOOD start-up delay	$C_{VREF} = 0.1\text{ }\mu\text{F}$ , S5 rising to PGOOD rising		2.5		ms

**ELECTRICAL CHARACTERISTICS (continued)**

 over operating free-air temperature range,  $V_{V5IN} = 5\text{ V}$ , VLDOIN is connected to VDDQ output,  $V_{MODE} = 0\text{ V}$ ,  $V_{S3} = V_{S5} = 5\text{ V}$  (unless otherwise noted)

PARAMETER		TEST CONDITION	MIN	TYP	MAX	UNIT
<b>PROTECTIONS</b>						
$I_{TRIP}$	TRIP source current	$T_A = 25^\circ\text{C}$ , $V_{TRIP} = 0.4\text{ V}$	9	10	11	$\mu\text{A}$
$TC_{ITRIP}$	TRIP source current temperature coefficient <sup>(2)</sup>			4700		ppm/ $^\circ\text{C}$
$V_{TRIP}$	$V_{TRIP}$ voltage range		0.2		3	V
$V_{OCL}$	Current limit threshold	$V_{TRIP} = 3.0\text{ V}$	360	375	390	mV
		$V_{TRIP} = 1.6\text{ V}$	190	200	210	
		$V_{TRIP} = 0.2\text{ V}$	20	25	30	
$V_{OCLN}$	Negative current limit threshold	$V_{TRIP} = 3.0\text{ V}$	-390	-375	-360	mV
		$V_{TRIP} = 1.6\text{ V}$	-210	-200	-190	
		$V_{TRIP} = 0.2\text{ V}$	-30	-25	-20	
$V_{ZC}$	Zero cross detection offset			0		mV
$V_{UVLO}$	V5IN UVLO threshold voltage	Wake-up	4.2	4.4	4.5	V
		Shutdown	3.7	3.9	4.1	
$V_{OVP}$	VDDQ OVP threshold voltage	OVP detect voltage	118%	120%	122%	
$t_{OVPDLY}$	VDDQ OVP propagation delay	With 100 mV over drive		430		ns
$V_{UVP}$	VDDQ UVP threshold voltage	UVP detect voltage	66%	68%	70%	
$t_{UVPDLY}$	VDDQ UVP delay			1		ms
$t_{UVPENDLY}$	VDDQ UVP enable delay			1.2		ms
$V_{OOB}$	OOB Threshold voltage			108%		
<b>THERMAL SHUTDOWN</b>						
$T_{SDN}$	Thermal shutdown threshold	Shutdown temperature <sup>(2)</sup>		140		$^\circ\text{C}$
		Hysteresis <sup>(2)</sup>		10		

(2) Ensured by design. Not production tested.

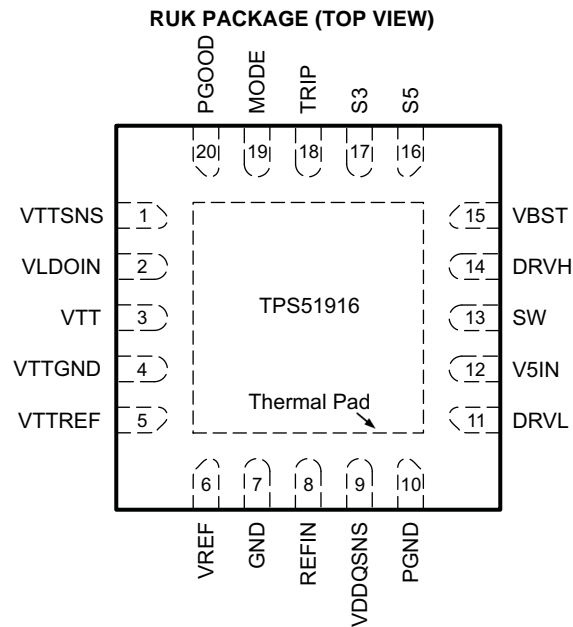
**DEVICE INFORMATION**

**PIN FUNCTIONS**

PIN		I/O	DESCRIPTION
NAME	NO.		
DRVH	14	O	High-side MOSFET gate driver output.
DRVL	11	O	Low-side MOSFET gate driver output.
GND	7	–	Signal ground.
MODE	19	I	Connect resistor to GND to configure switching frequency, control mode and discharge mode. (See <a href="#">Table 2</a> )
PGND	10	–	Gate driver power ground. $R_{DS(on)}$ current sensing input(+).
PGOOD	20	O	Powergood signal open drain output. PGOOD goes high when VDDQ output voltage is within the target range.
REFIN	8	I	Reference input for VDDQ. Connect to the midpoint of a resistor divider from VREF to GND. Add a capacitor for stable operation.
SW	13	I/O	High-side MOSFET gate driver return. $R_{DS(on)}$ current sensing input(-).
S3	17	I	S3 signal input. (See <a href="#">Table 1</a> )
S5	16	I	S5 signal input. (See <a href="#">Table 1</a> )
TRIP	18	I	Connect resistor to GND to set OCL at $V_{TRIP}/8$ . Output 10- $\mu$ A current at room temperature, $T_C = 4700$ ppm/ $^{\circ}$ C.
VBST	15	I	High-side MOSFET gate driver bootstrap voltage input. Connect a capacitor from the VBST pin to the SW pin.
VDDQSNS	9	I	VDDQ output voltage feedback. Reference input for VTTREF. Also serves as power supply for VTTREF.
VLDOIN	2	I	Power supply input for VTT LDO. Connect VDDQ in typical application.
VREF	6	O	1.8-V reference output.
VTT	3	O	VTT 2-A LDO output. Need to connect 10 $\mu$ F or larger capacitance for stability.
VTTGND	4	–	Power ground for VTT LDO.
VTTREF	5	O	Buffered VTT reference output. Need to connect 0.22 $\mu$ F or larger capacitance for stability.
VTTSENS	1	I	VTT output voltage feedback.
V5IN	12	I	5-V power supply input for internal circuits and MOSFET gate drivers.
Thermal pad	–	–	Thermal pad. Connect directly to system GND plane with multiple vias.

TPS51916

SLUSAE1D – DECEMBER 2010 – REVISED JUNE 2012

www.ti.com

FUNCTIONAL BLOCK DIAGRAM

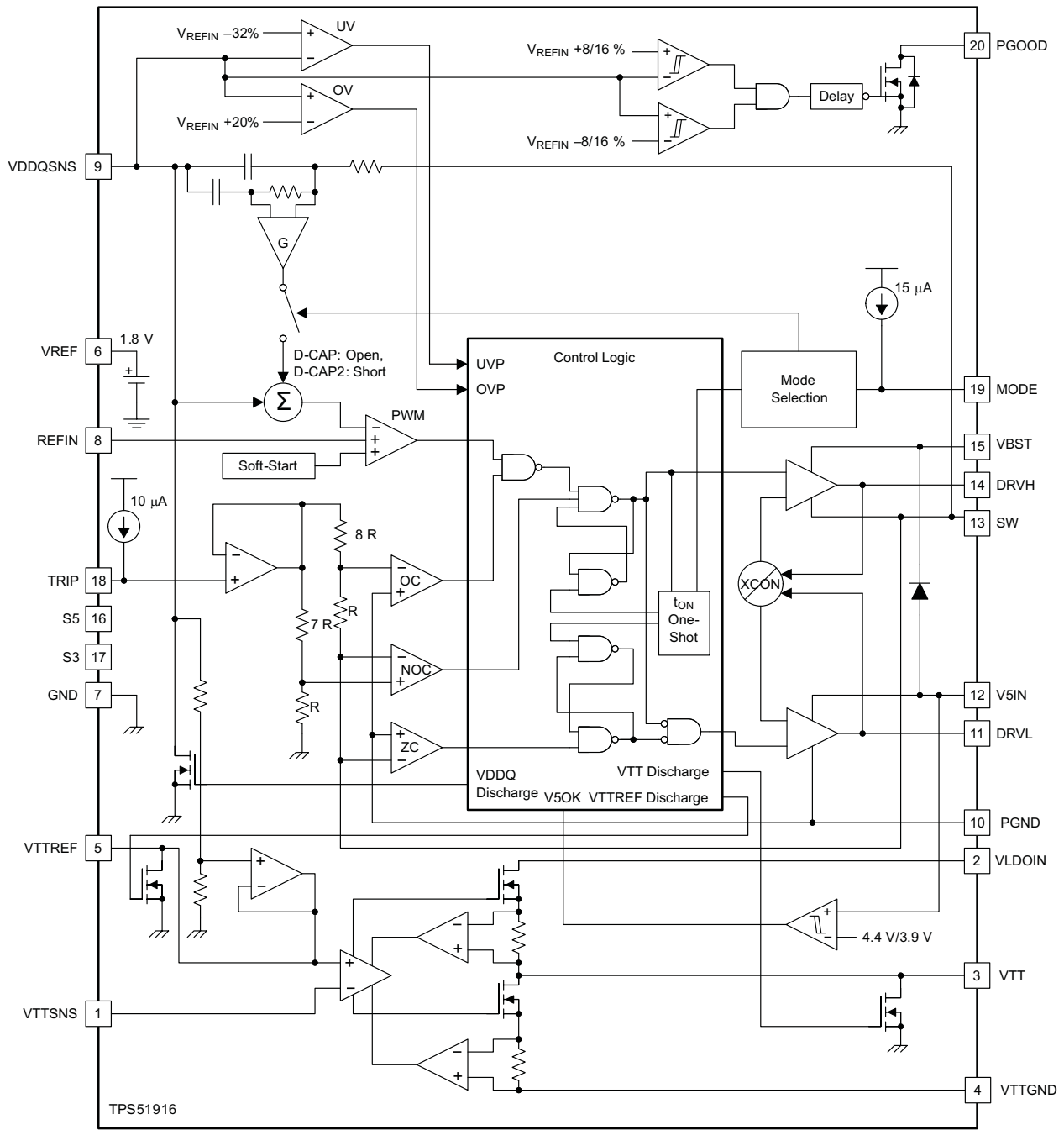



TYPICAL CHARACTERISTICS

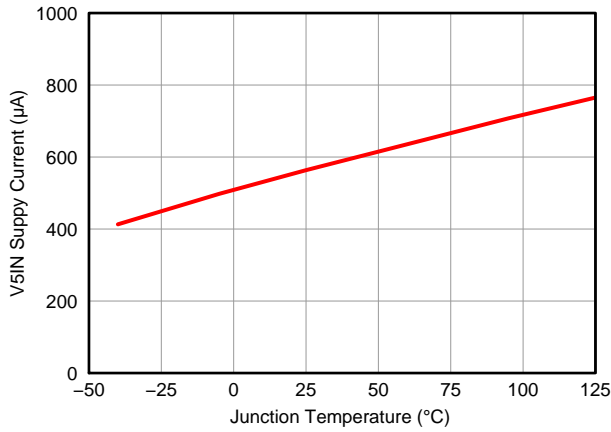

Figure 1. V5IN Supply Current vs Junction Temperature

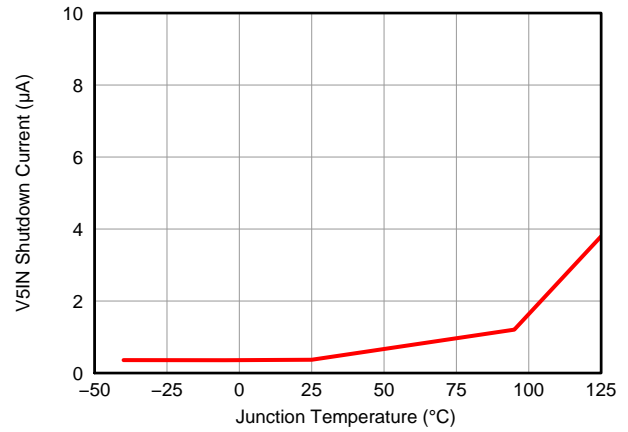

Figure 2. V5IN Shutdown Current vs Junction Temperature

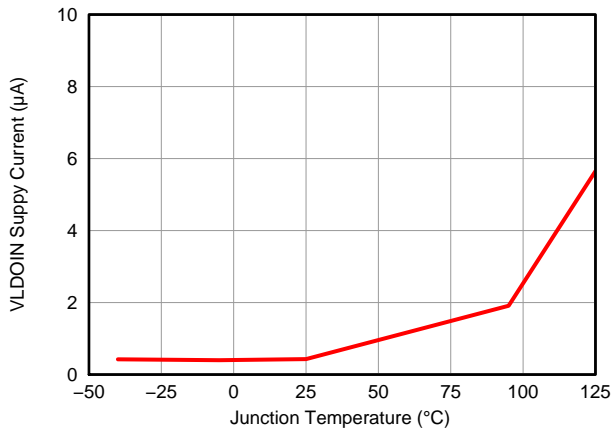

Figure 3. VLDOIN Supply Current vs Junction Temperature

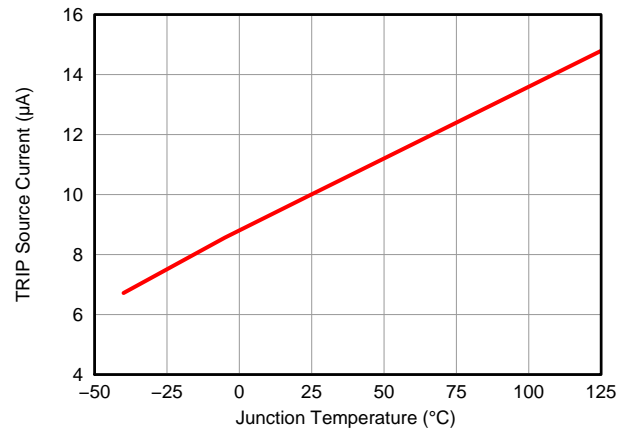

Figure 4. Current Sense Current vs Junction Temperature

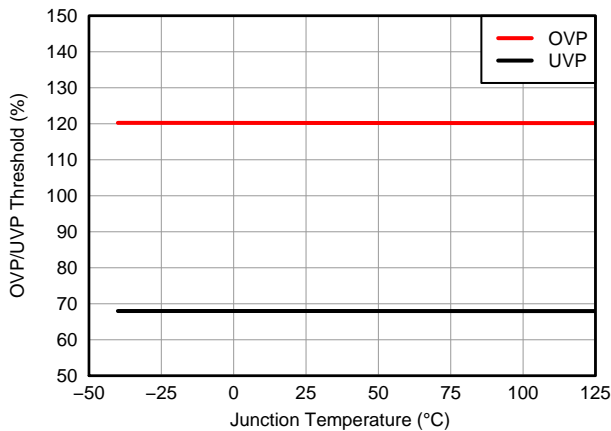

Figure 5. OVP/UVP Threshold vs Junction Temperature

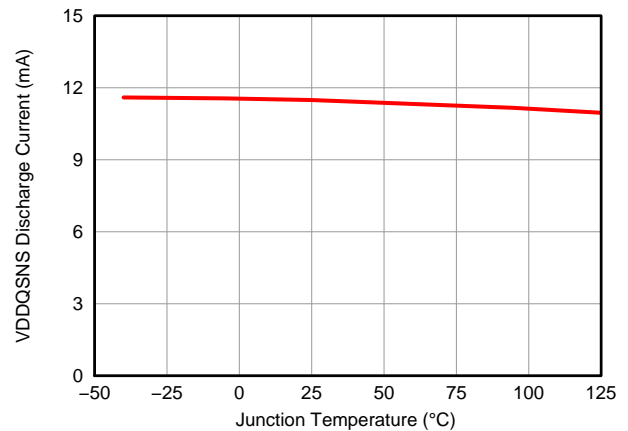

Figure 6. VDDQSNS Discharge Current vs Junction Temperature

TYPICAL CHARACTERISTICS (continued)

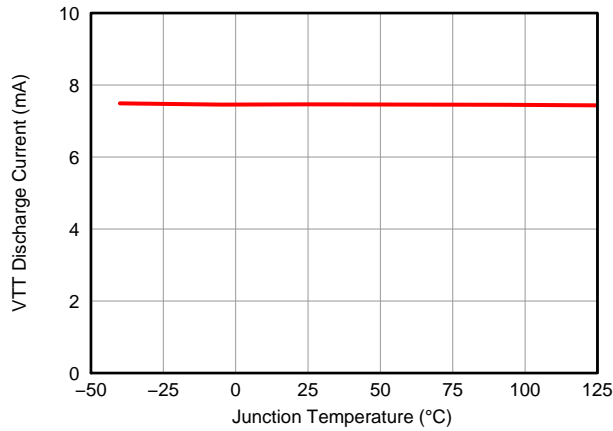

Figure 7. VTT Discharge Current vs Junction Temperature

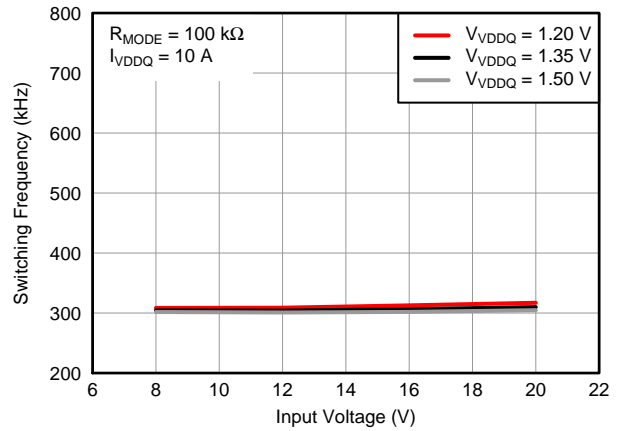

Figure 8. Switching Frequency vs Input Voltage

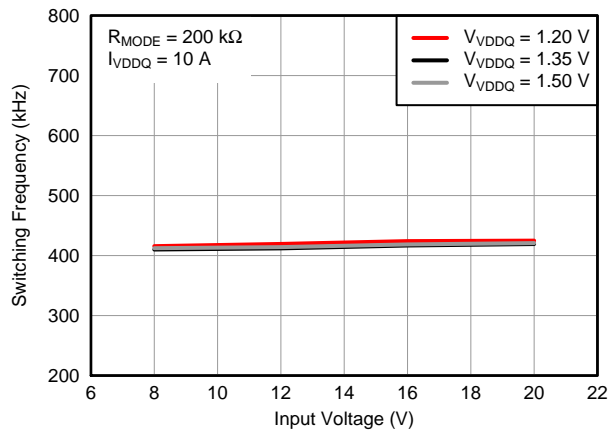

Figure 9. Switching Frequency vs Input Voltage

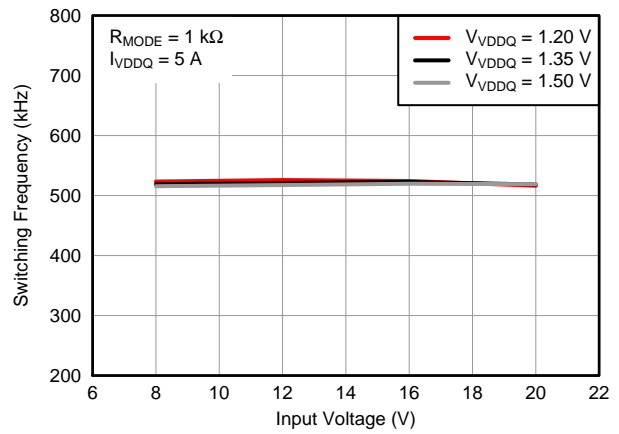

Figure 10. Switching Frequency vs Input Voltage

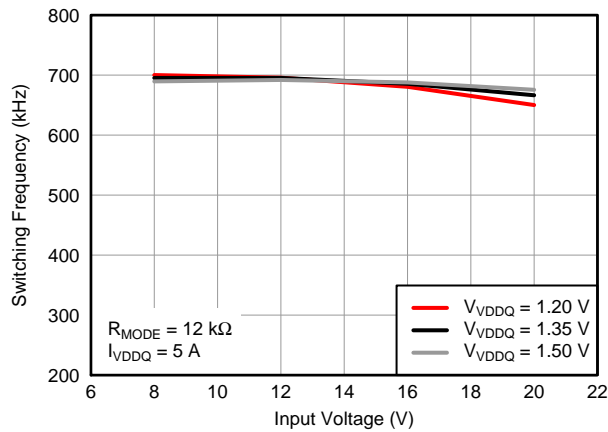

Figure 11. Switching Frequency vs Input Voltage

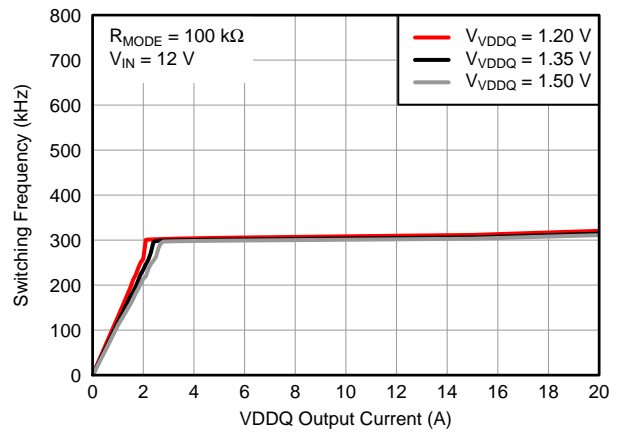

Figure 12. Switching Frequency vs Load Current

TYPICAL CHARACTERISTICS (continued)

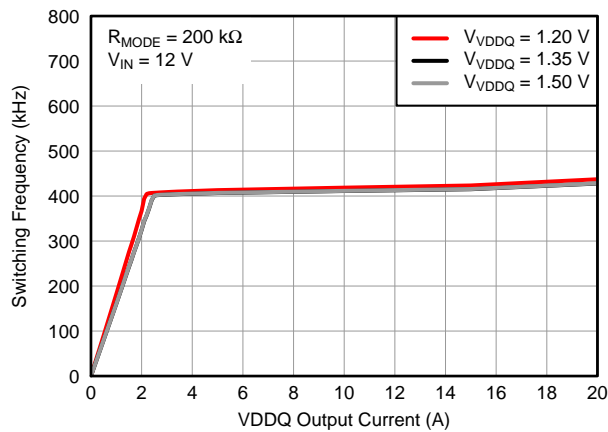

Figure 13. Switching Frequency vs Load Current

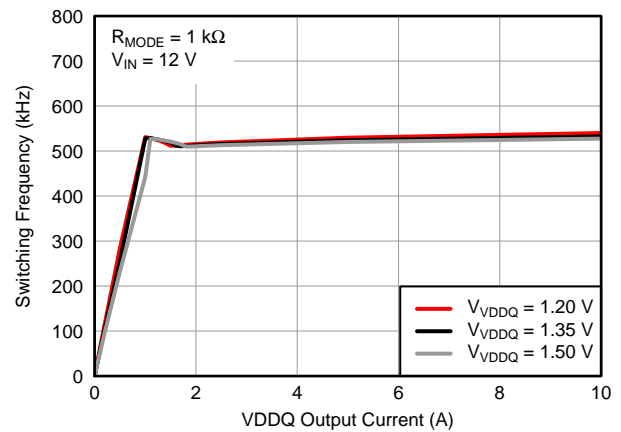

Figure 14. Switching Frequency vs Load Current

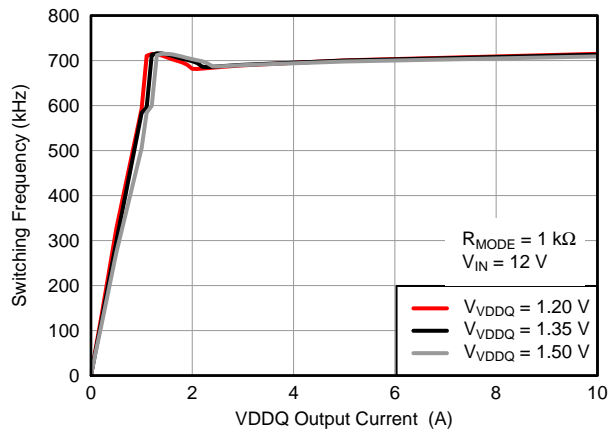

Figure 15. Switching Frequency vs Load Current

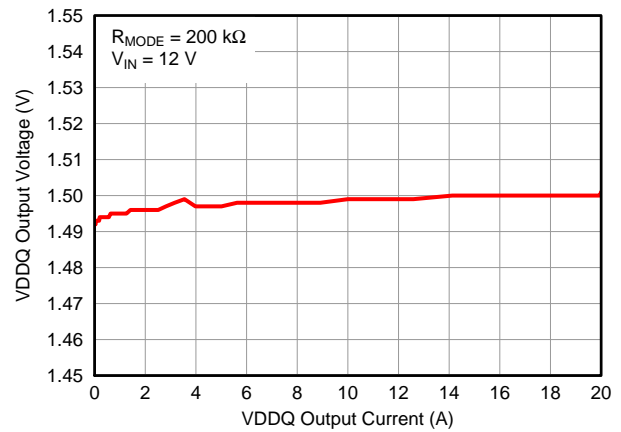

Figure 16. Load Regulation

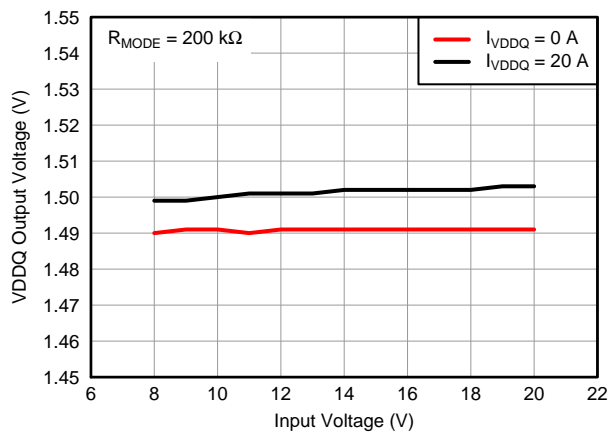

Figure 17. Line Regulation

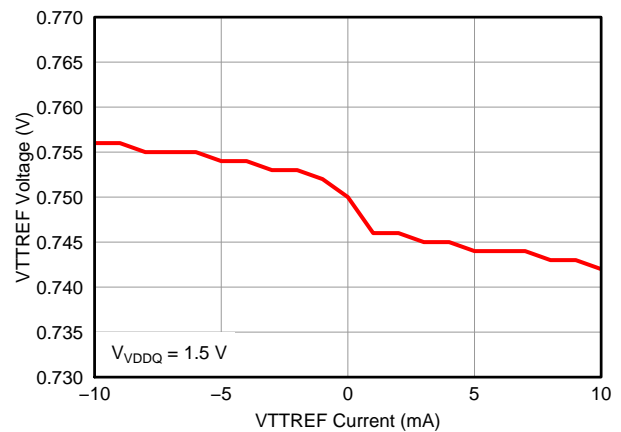

Figure 18. VTTREF Load Regulation

TYPICAL CHARACTERISTICS (continued)

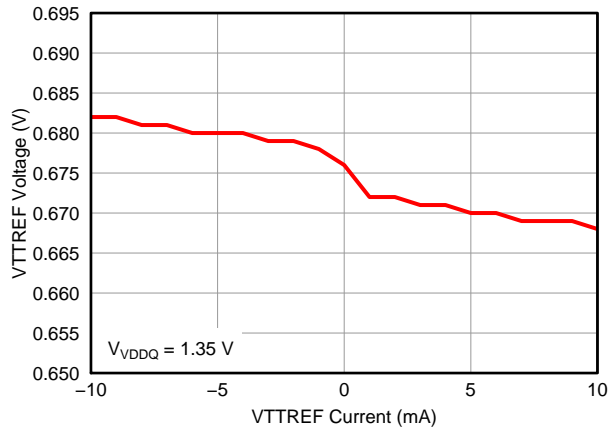

Figure 19. VTTREF Load Regulation

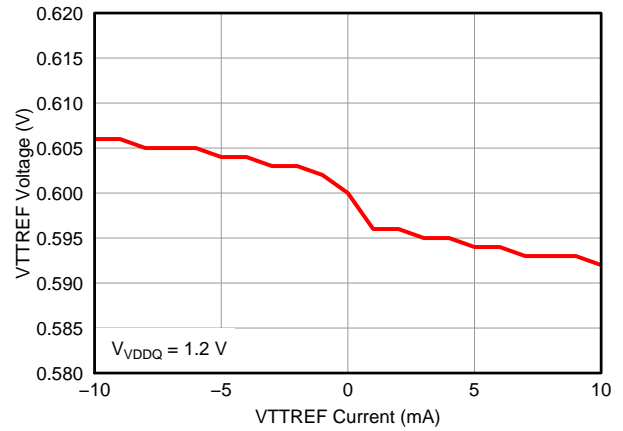

Figure 20. VTTREF Load Regulation

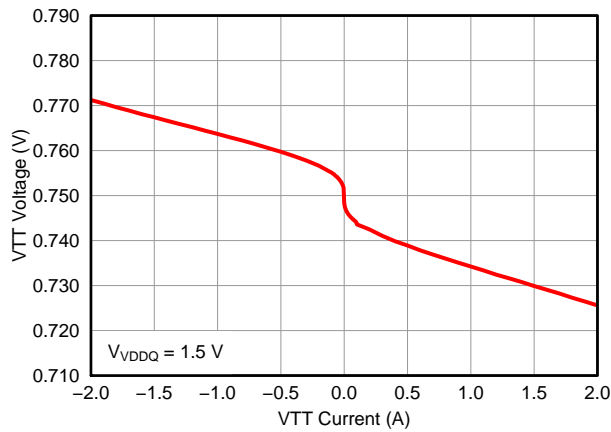

Figure 21. VTT Load Regulation

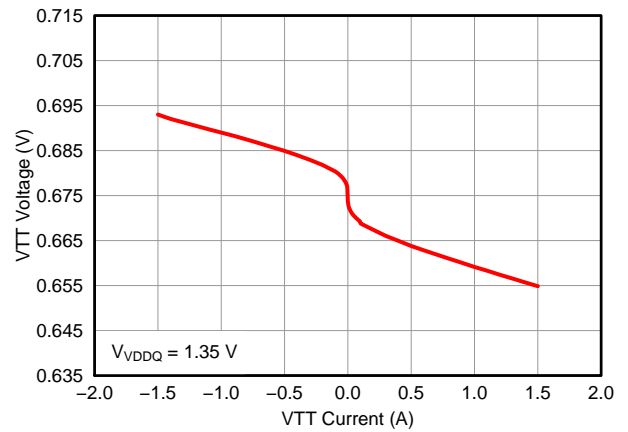

Figure 22. VTT Load Regulation

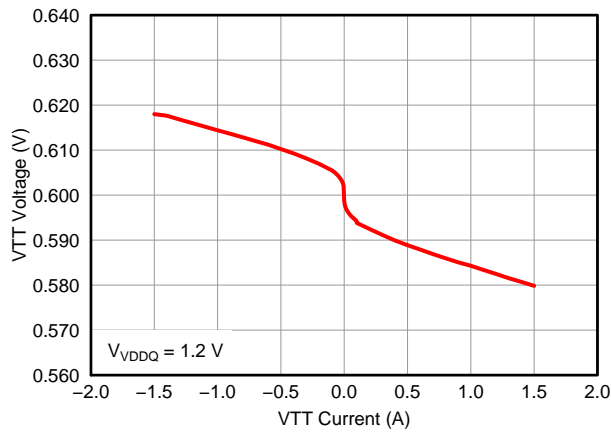

Figure 23. VTT Load Regulation

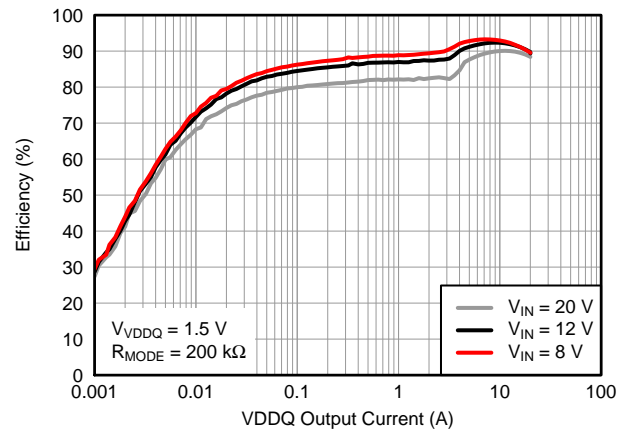

Figure 24. Efficiency

TYPICAL CHARACTERISTICS (continued)

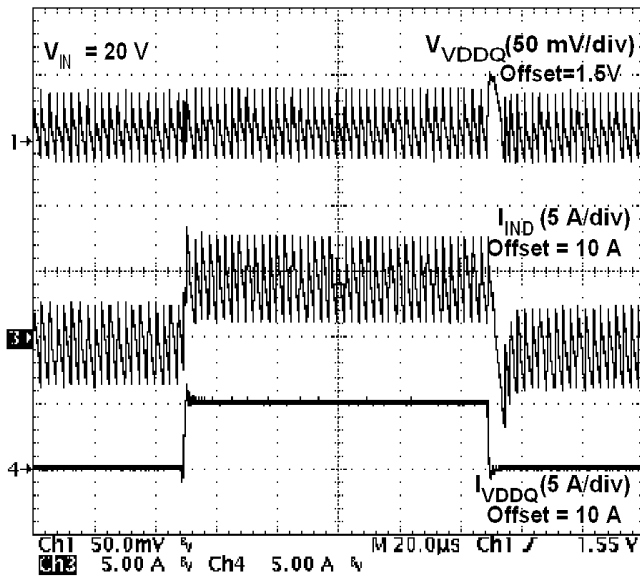

Figure 25. 1.5-V Load Transient Response

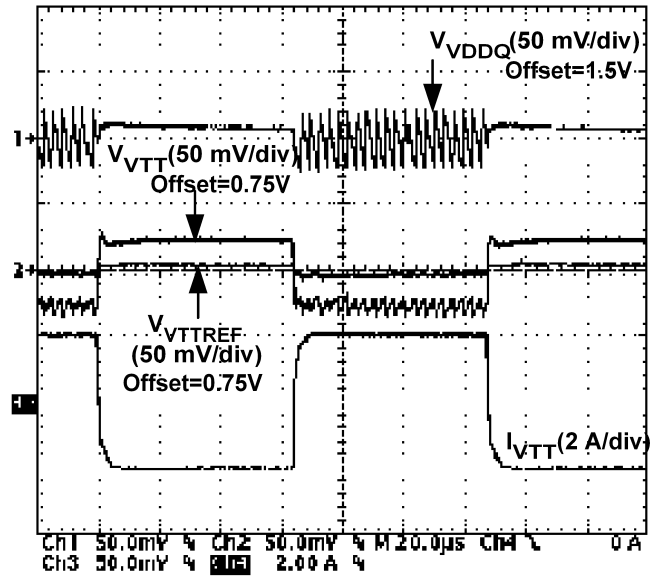

Figure 26. VTT Load Transient Response

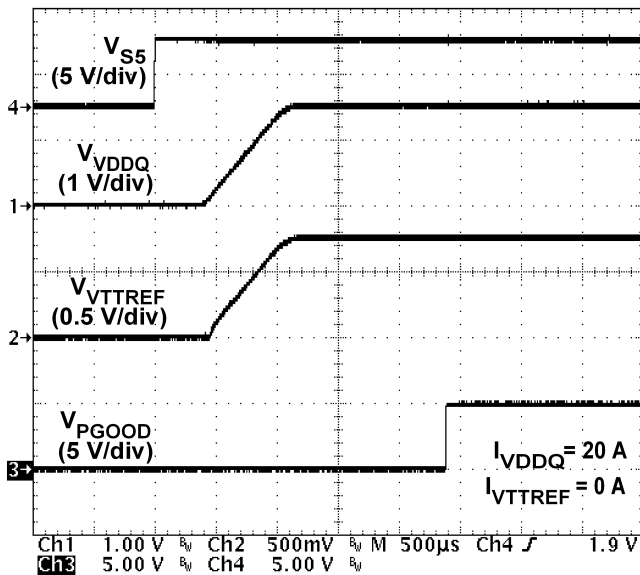

Figure 27. 1.5-V Startup Waveforms

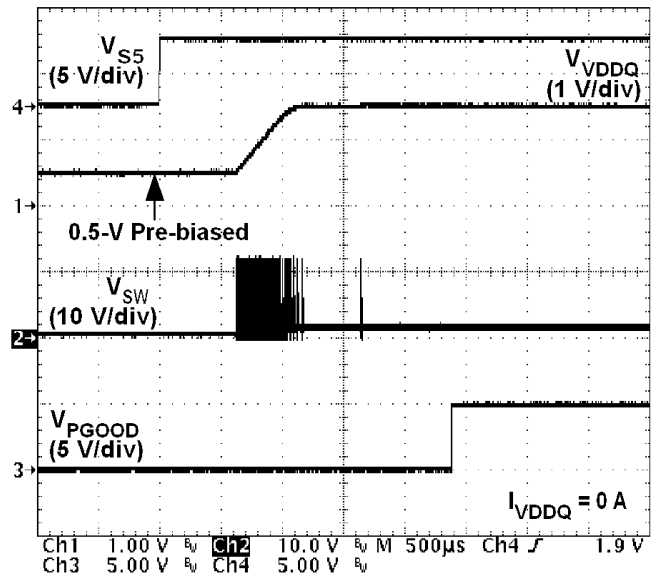

Figure 28. 1.5-V Startup Waveforms (0.5-V Pre-Biased)

TYPICAL CHARACTERISTICS (continued)

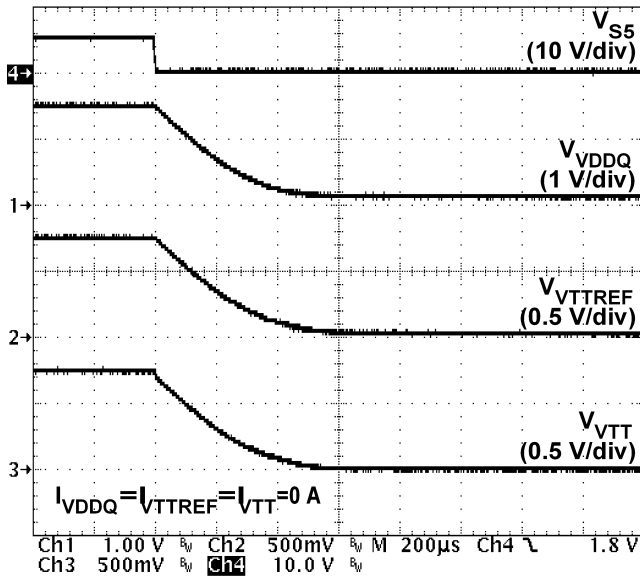

Figure 29. 1.5-V Soft-Stop Waveforms (Tracking Discharge)

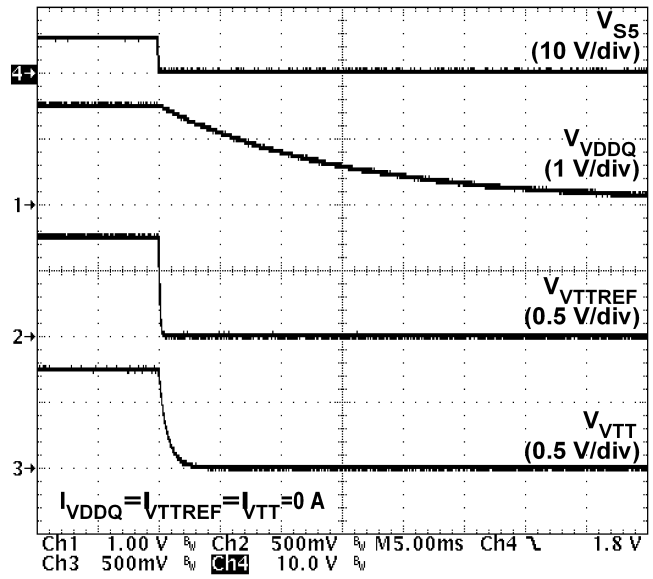

Figure 30. 1.5-V Soft-Stop Waveforms (Non-Tracking Discharge)

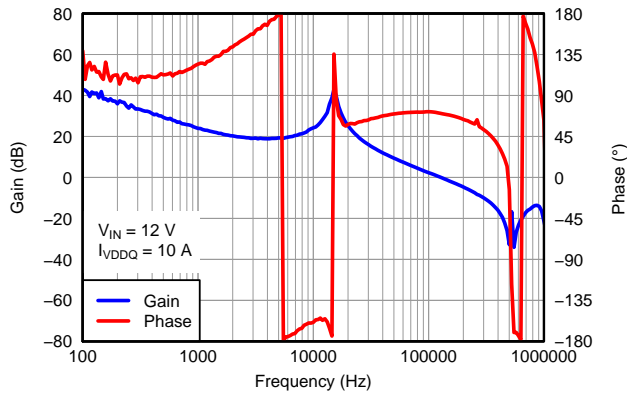

Figure 31. VDDQ Bode Plot

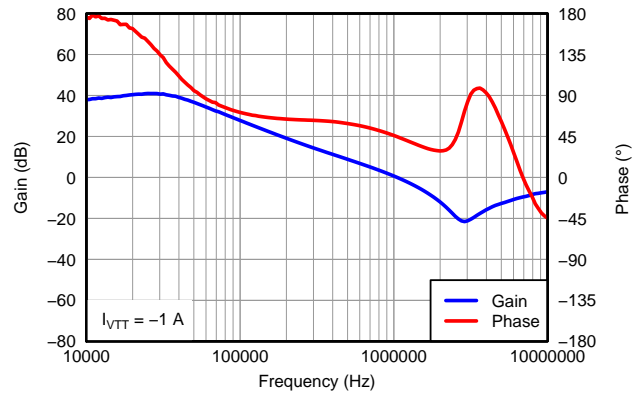

Figure 32. VTT Bode Plot (Sink)

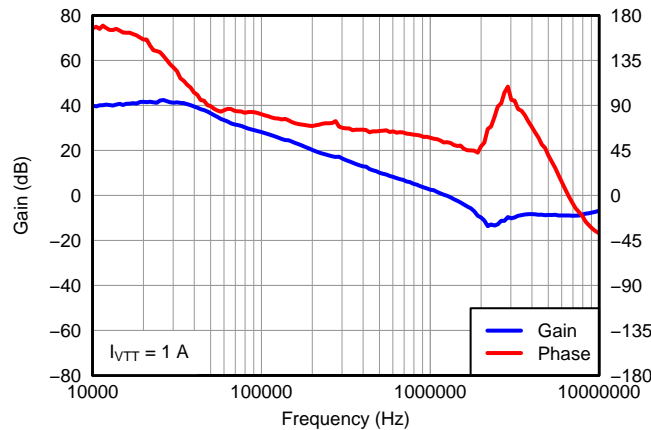

Figure 33. VTT Bode Plot (Source)

## APPLICATION INFORMATION

### VDDQ Switch Mode Power Supply Control

The TPS51916 supports two SMPS control architectures, D-CAP™ mode and D-CAP2™ mode. Both control modes do not require complex external compensation networks and are suitable for designs with small external components counts. The D-CAP™ mode provides fast transient response with appropriate amount of equivalent series resistance (ESR) on the output capacitors. The D-CAP2™ mode is dedicated for a configuration with very low ESR output capacitors such as multi-layer ceramic capacitors (MLCC). For the both modes, an adaptive on-time control scheme is used to achieve pseudo-constant frequency. The TPS51916 adjusts the on-time ( $t_{ON}$ ) to be inversely proportional to the input voltage ( $V_{IN}$ ) and proportional to the output voltage ( $V_{VDDQ}$ ). This makes a switching frequency fairly constant over the variation of input voltage at the steady state condition. These control modes and switching frequencies are selected by the MODE pin described in [Table 2](#).

### VREF and REFIN, VDDQ Output Voltage

The part provides a 1.8-V,  $\pm 0.8\%$  accurate, voltage reference from VREF. This output has a 300- $\mu$ A (max) current capability to drive the REFIN input voltage through a voltage divider circuit. A capacitor with a value of 0.1- $\mu$ F or larger should be attached close to the VREF terminal.

The VDDQ switch-mode power supply (SMPS) output voltage is defined by REFIN voltage, within the range between 0.7 V and 1.8 V, programmed by the resistor-divider connected between VREF and GND. (See [External Components Selection](#) section.) A few nano farads of capacitance from REFIN to GND is recommended for stable operation.

### Soft-Start and Powergood

Provide a voltage supply to VIN and V5IN before asserting S5 to high. TPS51916 provides integrated VDDQ soft-start functions to suppress in-rush current at start-up. The soft-start is achieved by controlling internal reference voltage ramping up. [Figure 34](#) shows the start-up waveforms. The switching regulator waits for 400 $\mu$ s after S5 assertion. The MODE pin voltage is read in this period. A typical VDDQ ramp up duration is 700 $\mu$ s.

TPS51916 has a powergood open-drain output that indicates the VDDQ voltage is within the target range. The target voltage window and transition delay times of the PGOOD comparator are  $\pm 8\%$  (typ) and 1-ms delay for assertion (low to high), and  $\pm 16\%$  (typ) and 330-ns delay for de-assertion (high to low) during running. The PGOOD start-up delay is 2.5 ms after S5 is asserted to high. Note that the time constant which is composed of the REFIN capacitor and a resistor divider needs to be short enough to reach the target value before PGOOD comparator enabled.

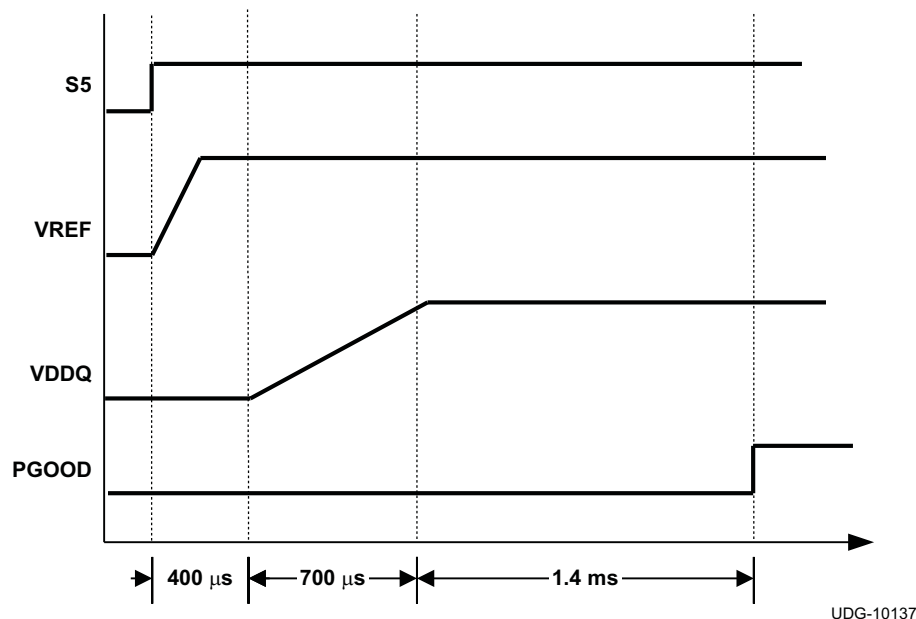

Figure 34. Typical Start-up Waveforms

## Power State Control

The TPS51916 has two input pins, S3 and S5, to provide simple control scheme of power state. All of VDDQ, VTTREF and VTT are turned on at S0 state (S3=S5=high). In S3 state (S3=low, S5=high), VDDQ and VTTREF voltages are kept on while VTT is turned off and left at high impedance state (high-Z). The VTT output floats and does not sink or source current in this state. In S4/S5 states (S3=S5=low), all of the three outputs are turned off and discharged to GND according to the discharge mode selected by MODE pin. Each state code represents as follow; S0 = full ON, S3 = suspend to RAM (STR), S4 = suspend to disk (STD), S5 = soft OFF. (See [Table 1](#))

**Table 1. S3/S5 Power State Control**

STATE	S3	S5	VREF	VDDQ	VTTREF	VTT
S0	HI	HI	ON	ON	ON	ON
S3	LO	HI	ON	ON	ON	OFF(High-Z)
S4/S5	LO	LO	OFF	OFF(Discharge)	OFF(Discharge)	OFF(Discharge)

## MODE Pin Configuration

The TPS51916 reads the MODE pin voltage when the S5 signal is raised high and stores the status in a register. A 15- $\mu$ A current is sourced from the MODE pin during this time to read the voltage across the resistor connected between the pin and GND. [Table 2](#) shows resistor values, corresponding control mode, switching frequency and discharge mode configurations.

**Table 2. MODE Selection**

MODE NO.	RESISTANCE BETWEEN MODE AND GND (k $\Omega$ )	CONTROL MODE	SWITCHING FREQUENCY (kHz)	DISCHARGE MODE
7	200	D-CAP™	400	Tracking
6	100		300	
5	68		300	
4	47	D-CAP2™	400	Non-tracking
3	33		500	
2	22		670	
1	12		670	
0	1		500	Tracking

## Discharge Control

In S4/S5 state, VDDQ, VTT, and VTTREF outputs are discharged based on the respective discharge mode selected above. The tracking discharge mode discharges VDDQ output through the internal VTT regulator transistors enabling quick discharge operation. The VTT output maintains tracking of the VTTREF voltage in this mode. (Please refer to [Figure 29](#)) After 4 ms of tracking discharge operation, the mode changes to non-tracking discharge. The VDDQ output must be connected to the VLDOIN pin in this mode. The non-tracking mode discharges the VDDQ and VTT pins using internal MOSFETs that are connected to corresponding output terminals. The non-tracking discharge is slow compared with the tracking discharge due to the lower current capability of these MOSFETs. (Please refer to [Figure 30](#))



## D-CAP™ Mode

Figure 35 shows a simplified model of D-CAP™ mode architecture.

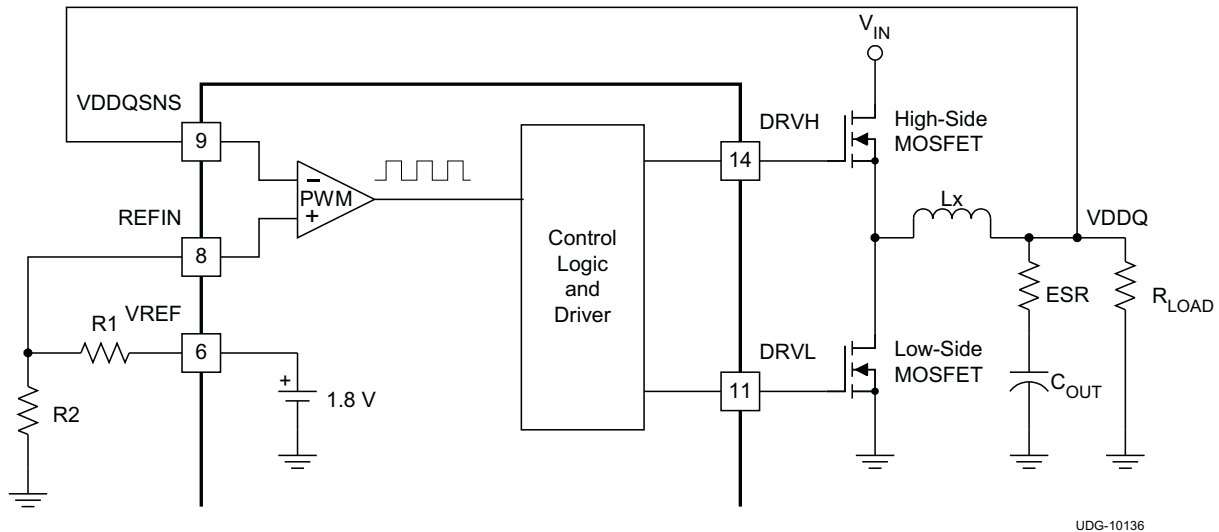

Figure 35. Simplified D-CAP™ Model

The VDDQSNS voltage is compared with REFIN voltage. The PWM comparator creates a set signal to turn on the high-side MOSFET. The gain and speed of the comparator is high enough to maintain the voltage at the beginning of each on-cycle (or the end of each off-cycle) to be substantially constant. The DC output voltage monitored at VDDQ may have line regulation due to ripple amplitude that slightly increases as the input voltage increase. The D-CAP™ mode offers flexibility on output inductance and capacitance selections with ease-of-use without complex feedback loop calculation and external components. However, it does require a sufficient level of ESR that represents inductor current information for stable operation and good jitter performance. Organic semiconductor capacitor(s) or specialty polymer capacitor(s) are recommended.

The requirement for loop stability is simple and is described in Equation 1. The 0-dB frequency,  $f_0$  defined in Equation 1, is recommended to be lower than 1/3 of the switching frequency to secure proper phase margin.

$$f_0 = \frac{1}{2\pi \times \text{ESR} \times C_{\text{OUT}}} \leq \frac{f_{\text{SW}}}{3}$$

where

- ESR is the effective series resistance of the output capacitor
- $C_{\text{OUT}}$  is the capacitance of the output capacitor
- $f_{\text{sw}}$  is switching frequency

(1)

Jitter is another attribute caused by signal-to-noise ratio of the feedback signal. One of the major factors that determine jitter performance in D-CAP™ mode is the down-slope angle of the VDDQSNS ripple voltage. Figure 36 shows, in the same noise condition, that jitter is improved by making the slope angle larger.

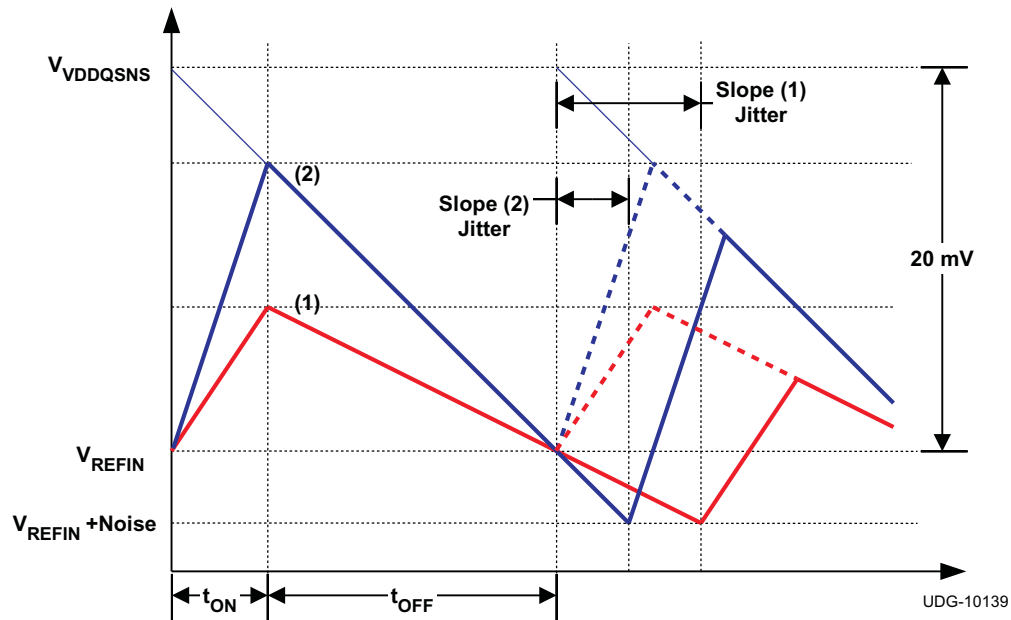

**Figure 36. Ripple Voltage Slope and Jitter Performance**

For a good jitter performance, use the recommended down slope of approximately 20 mV per switching period as shown in Figure 36 and Equation 2.

$$\frac{V_{OUT} \times ESR}{f_{SW} \times L_X} \geq 20\text{mV}$$

where

- $V_{OUT}$  is the VDDQ output voltage
- $L_X$  is the inductance

(2)

## D-CAP2™ Mode Operation

Figure 37 shows simplified model of D-CAP2™ architecture.

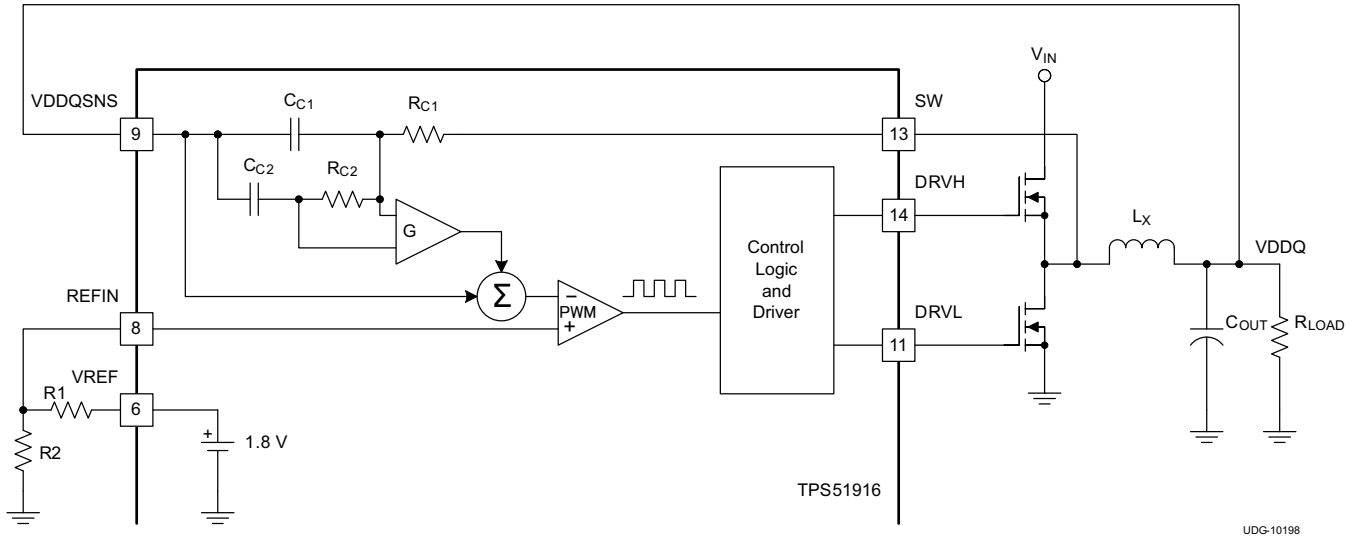

Figure 37. Simplified Modulator Using D-CAP2™ Mode

The D-CAP2™ mode in the TPS51916 includes an internal feedback network enabling the use of very low ESR output capacitor(s) such as multi-layer ceramic capacitors. The role of the internal network is to sense the ripple component of the inductor current information and combine it with voltage feedback signal. Using  $R_{C1}=R_{C2}\equiv R_C$  and  $C_{C1}=C_{C2}\equiv C_C$ , 0-dB frequency of the D-CAP2™ mode is given by Equation 3. It is recommended that the 0-dB frequency ( $f_0$ ) be lower than 1/3 of the switching frequency to secure the proper phase margin

$$f_0 = \frac{R_C \times C_C}{2\pi \times G \times L_X \times C_{OUT}} \leq \frac{f_{SW}}{3}$$

where

- G is gain of the amplifier which amplifies the ripple current information generated by the compensation circuit (3)

The typical G value is 0.25, and typical  $R_C C_C$  time constant values for 500 kHz and 670 kHz operation are 23  $\mu$ s and 14.6  $\mu$ s, respectively.

For example, when  $f_{SW}=500$  kHz and  $L_X=1$   $\mu$ H,  $C_{OUT}$  should be larger than 88  $\mu$ F.

When selecting the capacitor, pay attention to its characteristics. For MLCC use X5R or better dielectric and consider the derating of the capacitance by both DC bias and AC bias. When derating by DC bias and AC bias are 80% and 50%, respectively, the effective derating is 40% because  $0.8 \times 0.5 = 0.4$ . The capacitance of specialty polymer capacitors may change depending on the operating frequency. Consult capacitor manufacturers for specific characteristics.

## Light-Load Operation

In auto-skip mode, the TPS51916 SMPS control logic automatically reduces its switching frequency to improve light-load efficiency. To achieve this intelligence, a zero cross detection comparator is used to prevent negative inductor current by turning off the low-side MOSFET. Equation 4 shows the boundary load condition of this skip mode and continuous conduction operation.

$$I_{LOAD(LL)} = \frac{(V_{IN} - V_{OUT})}{2 \times L_X} \times \frac{V_{OUT}}{V_{IN}} \times \frac{1}{f_{SW}} \quad (4)$$

## VTT and VTTREF

TPS51916 integrates two high performance, low-drop-out linear regulators, VTT and VTTREF, to provide complete DDR2/DDR3/DDR3L power solutions. The VTTREF has a 10-mA sink/source current capability, and tracks  $\frac{1}{2}$  of VDDQSNS with  $\pm 1\%$  accuracy using an on-chip  $\frac{1}{2}$  divider. A 0.22- $\mu\text{F}$  (or larger) ceramic capacitor must be connected close to the VTTREF terminal to ensure stable operation. The VTT responds quickly to track VTTREF within  $\pm 40$  mV at all conditions, and the current capability is 2 A for both sink and source. A 10- $\mu\text{F}$  (or larger) ceramic capacitor(s) need to be connected close to the VTT terminal for stable operation. To achieve tight regulation with minimum effect of wiring resistance, a remote sensing terminal, VTTSNS, should be connected to the positive node of VTT output capacitor(s) as a separate trace from the high-current line to the VTT pin. (Please refer to the [Layout Considerations](#) section for details.)

When VTT is not required in the design, following treatment is strongly recommended.

- Connect VLDOIN to VDDQ.
- Tie VTTSNS to VTT, and remove capacitors from VTT to float.
- Connect VTTGND to GND.
- Select MODE2, 3, 4 or 5 shown in [Table 2](#) (Select Non-tracking discharge mode).
- Maintain a 0.22- $\mu\text{F}$  capacitor connected at VTTREF.
- Pull down S3 to GND with 1-k $\Omega$  resistance.

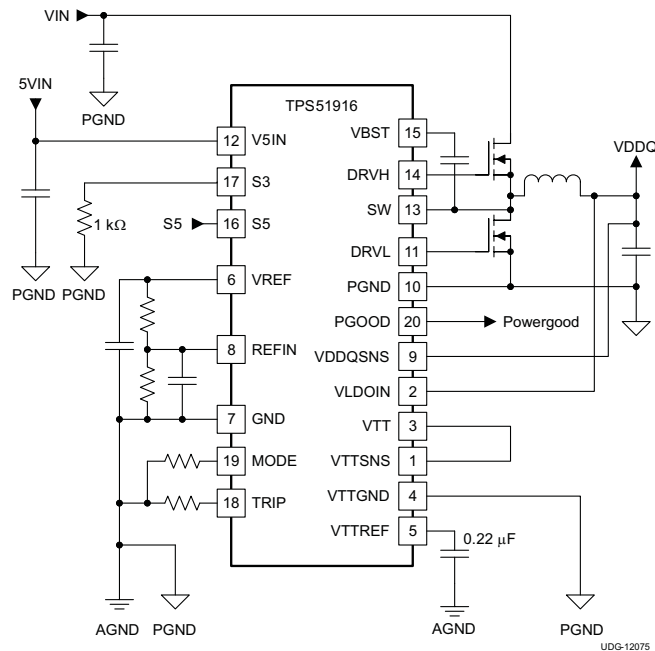

**Figure 38. Application Circuit When VTT Is Not Required**

## VDDQ Overvoltage and Undervoltage Protection

The TPS51916 sets the overvoltage protection (OVP) when VDDQSNS voltage reaches a level 20% (typ) higher than the REFIN voltage. When an OV event is detected, the controller changes the output target voltage to 0 V. This usually turns off DRVH and forces DRVL to be on. When the inductor current begins to flow through the low-side MOSFET and reaches the negative OCL, DRVL is turned off and DRVH is turned on, for a minimum on-time.

After the minimum on-time expires, DRVH is turned off and DRVL is turned on again. This action minimizes the output node undershoot due to LC resonance. When the VDDQSNS reaches 0 V, the driver output is latched as DRVH off, DRVL on. VTTREF and VTT are turned off and discharged using the non-tracking discharge MOSFETs regardless of the tracking mode.

The undervoltage protection (UVP) latch is set when the VDDQSNS voltage remains lower than 68% (typ) of the REFIN voltage for 1 ms or longer. In this fault condition, the controller latches DRVH low and DRVL low and discharges the VDDQ, VTT and VTTREF outputs. UVP detection function is enabled after 1.2 ms of SMPS operation to ensure startup.

To release the OVP and UVP latches, toggle S5 or adjust the V5IN voltage down and up beyond the undervoltage lockout threshold.

### VDDQ Out-of-Bound Operation

When the output voltage rises to 8% above the target value, the out-of-bound operation starts. During the out-of-bound condition, the controller operates in forced PWM-only mode. Turning on the low-side MOSFET beyond the zero inductor current quickly discharges the output capacitor. During this operation, the cycle-by-cycle negative overcurrent limit is also valid. Once the output voltage returns to within regulation range, the controller resumes to auto-skip mode.

### VDDQ Overcurrent Protection

The VDDQ SMPS has cycle-by-cycle overcurrent limiting protection. The inductor current is monitored during the off-state using the low-side MOSFET  $R_{DS(on)}$ , and the controller maintains the off-state when the inductor current is larger than the overcurrent trip level. The current monitor circuit inputs are PGND and SW pins so that those should be properly connected to the source and drain terminals of low-side MOSFET. The overcurrent trip level,  $V_{OCTRIP}$ , is determined by Equation 5, where  $R_{TRIP}$  is the value of the resistor connected between the TRIP pin and GND, and  $I_{TRIP}$  is the current sourced from the TRIP pin.  $I_{TRIP}$  is 10  $\mu$ A typically at room temperature, and has 4700ppm/ $^{\circ}$ C temperature coefficient to compensate the temperature dependency of the low-side MOSFET  $R_{DS(on)}$ .

$$V_{OCTRIP} = R_{TRIP} \times \frac{I_{TRIP}}{8} \quad (5)$$

Because the comparison is done during the off-state,  $V_{OCTRIP}$  sets the valley level of the inductor current. The load current OCL level,  $I_{OCL}$ , can be calculated by considering the inductor ripple current as shown in Equation 6.

$$I_{OCL} = \left( \frac{V_{OCTRIP}}{R_{DS(on)}} \right) + \frac{I_{IND(ripple)}}{2} = \left( \frac{V_{OCTRIP}}{R_{DS(on)}} \right) + \frac{1}{2} \times \frac{V_{IN} - V_{OUT}}{L_X} \times \frac{V_{OUT}}{f_{SW} \times V_{IN}}$$

where

- $I_{IND(ripple)}$  is inductor ripple current (6)

In an overcurrent condition, the current to the load exceeds the current to the output capacitor, thus the output voltage tends to fall down. Eventually, it crosses the undervoltage protection threshold and shuts down.

### VTT Overcurrent Protection

The LDO has an internally fixed constant overcurrent limiting of 3-A (typ) for both sink and source operation.

### V5IN Undervoltage Lockout Protection

The TPS51916 has a 5-V supply undervoltage lockout protection (UVLO) threshold. When the V5IN voltage is lower than UVLO threshold voltage, typically 3.9 V, VDDQ, VTT and VTTREF are shut off. This is a non-latch protection.

### Thermal Shutdown

The TPS51916 includes an internal temperature monitor. If the temperature exceeds the threshold value, 140 $^{\circ}$ C (typ), VDDQ, VTT and VTTREF are shut off. The state of VDDQ is open, and that of VTT and VTTREF are high impedance (high-Z) at thermal shutdown. The discharge functions of all outputs are disabled. This is a non-latch protection and the operation is restarted with soft-start sequence when the device temperature is reduced by 10 $^{\circ}$ C (typ).

## External Components Selection

The external components selection is simple in D-CAP™ mode.

### 1. DETERMINE THE VALUE OF R1 AND R2

The output voltage is determined by the value of the voltage-divider resistor, R1 and R2 as shown in [Figure 35](#). R1 is connected between VREF and REFIN pins, and R2 is connected between the REFIN pin and GND. Setting R1 as 10-kΩ is a good starting point. Determine R2 using [Equation 7](#).

$$R2 = \frac{R1}{\left( \frac{1.8}{V_{OUT} - \left( \frac{I_{IND(ripple)} \times ESR}{2} \right)} \right) - 1} \quad (7)$$

### 2. CHOOSE THE INDUCTOR

The inductance value should be determined to yield a ripple current of approximately ¼ to ½ of maximum output current. Larger ripple current increases output ripple voltage and improves the signal-to-noise ratio and helps stable operation.

$$L_X = \frac{1}{I_{IND(ripple)} \times f_{SW}} \times \frac{(V_{IN(max)} - V_{OUT}) \times V_{OUT}}{V_{IN(max)}} = \frac{3}{I_{O(max)} \times f_{SW}} \times \frac{(V_{IN(max)} - V_{OUT}) \times V_{OUT}}{V_{IN(max)}} \quad (8)$$

The inductor needs a low direct current resistance (DCR) to achieve good efficiency, as well as enough room above peak inductor current before saturation. The peak inductor current can be estimated in [Equation 9](#).

$$I_{IND(peak)} = \frac{R_{TRIP} \times I_{TRIP}}{8 \times R_{DS(on)}} + \frac{1}{L \times f_{SW}} \times \frac{(V_{IN(max)} - V_{OUT}) \times V_{OUT}}{V_{IN(max)}} \quad (9)$$

### 3. CHOOSE THE OCL SETTING RESISTANCE, R<sub>TRIP</sub>

Combining [Equation 5](#) and [Equation 6](#), R<sub>TRIP</sub> can be obtained using [Equation 10](#).

$$R_{TRIP} = \frac{8 \times \left( I_{OCL} - \left( \frac{(V_{IN} - V_{OUT})}{(2 \times L_X)} \right) \times \frac{V_{OUT}}{(f_{SW} \times V_{IN})} \right) \times R_{DS(on)}}{I_{TRIP}} \quad (10)$$

### 4. CHOOSE THE OUTPUT CAPACITORS

#### D-CAP™ Mode

Organic semiconductor capacitor(s) or specialty polymer capacitor(s) are recommended. Determine ESR to meet small signal stability and recommended ripple voltage. A quick reference is shown in [Equation 11](#) and [Equation 12](#).

$$\frac{1}{2\pi \times ESR \times C_{OUT}} \leq \frac{f_{SW}}{3} \quad (11)$$

$$\frac{V_{OUT} \times ESR}{f_{SW} \times L_X} \geq 20 \text{ mV} \quad (12)$$

#### D-CAP2™ Mode

Determine output capacitance to meet small signal stability as shown in [Equation 13](#).

$$\frac{R_C \times C_C}{2\pi \times G \times L_X \times C_{OUT}} \leq \frac{f_{SW}}{3}$$

where

- $R_C \times C_C$  time constant is 23  $\mu$ s for 500 kHz operation (or 14.6  $\mu$ s for 670 kHz operation)
- $G = 0.25$

(13)

TPS51916 Application Circuits

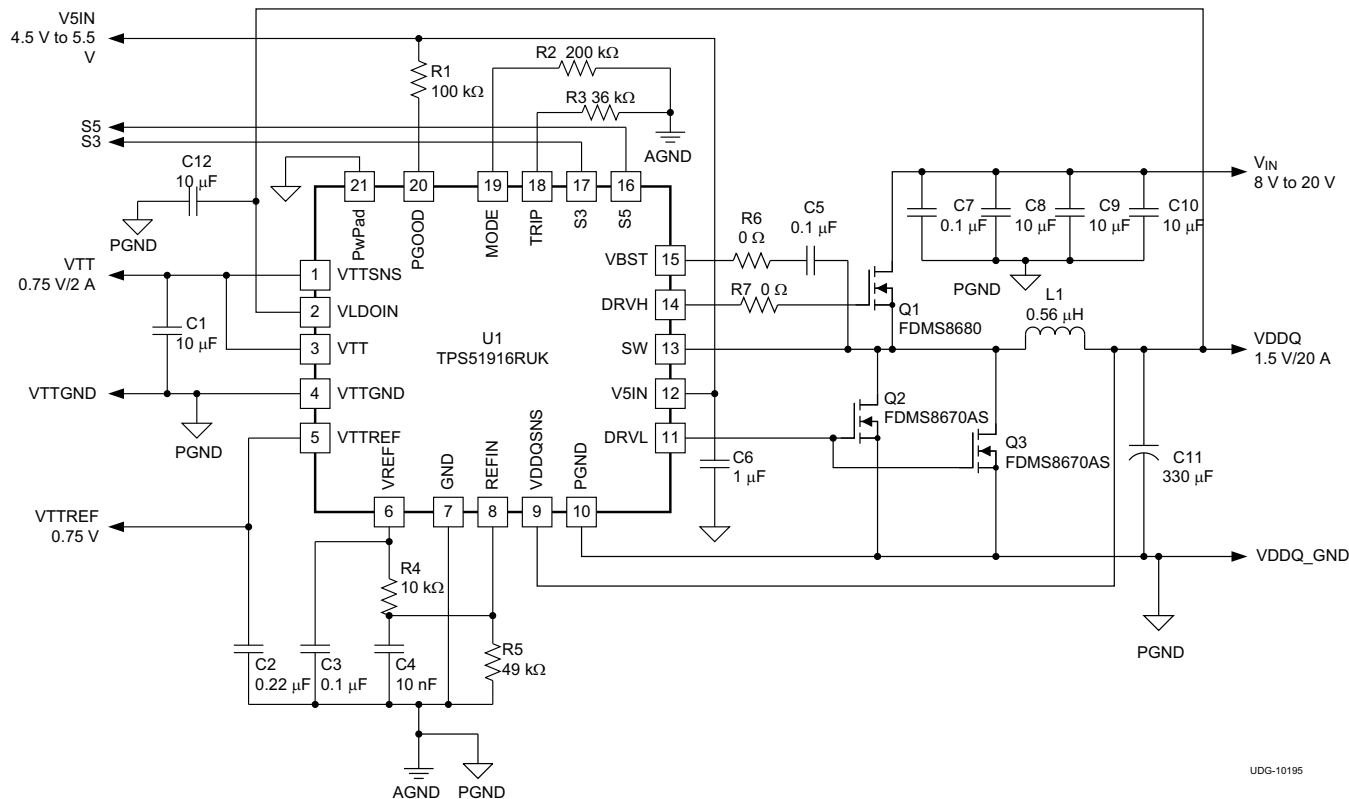

Figure 39. DDR3, D-CAP™ 400-kHz Application Circuit, Tracking Discharge

Table 3. DDR3, D-CAP™ 400-kHz Application Circuit, List of Materials

REFERENCE DESIGNATOR	QTY	SPECIFICATION	MANUFACTURE	PART NUMBER
C8, C9, C10	3	10 $\mu$ F, 25 V	Taiyo Yuden	TMK325BJ106MM
C11	1	330 $\mu$ F, 2V, 6 m $\Omega$	Panasonic	EEFSX0D331XE
L1	1	0.56 $\mu$ H, 21 A, 1.56 m $\Omega$	Panasonic	ETQP4LR56WFC
Q1	1	30 V, 35 A, 8.5 m $\Omega$	Fairchild	FDMS8680
Q2, Q3	2	30 V, 42 A, 3.5 m $\Omega$	Fairchild	FDMS8670AS

# TPS51916

SLUSAE1D – DECEMBER 2010 – REVISED JUNE 2012

www.ti.com

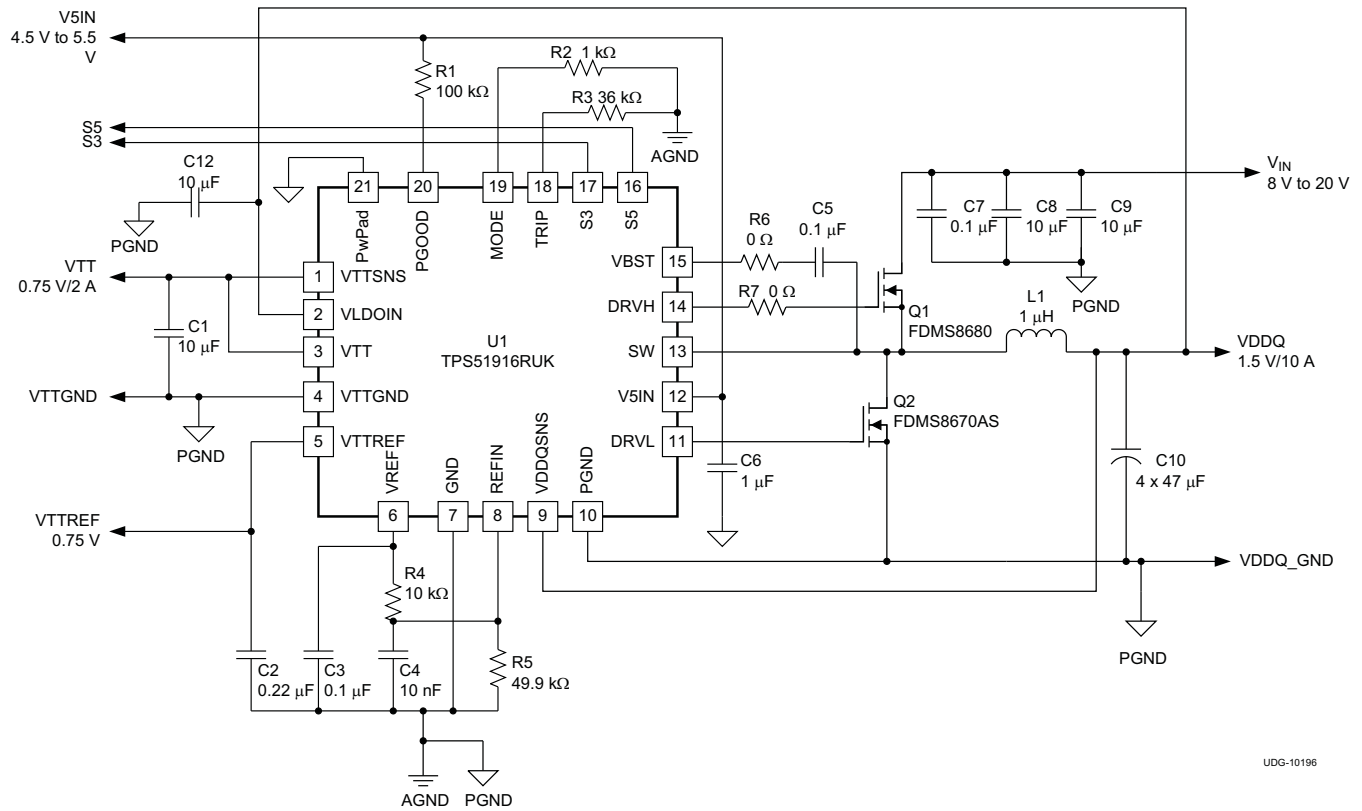

UDG-10196

Figure 40. DDR3, DCAP-2™ 500-kHz Application Circuit, Tracking Discharge

Table 4. DDR3, DCAP-2™ 500-kHz Application Circuit, List of Materials

REFERENCE DESIGNATOR	QTY	SPECIFICATION	MANUFACTURE	PART NUMBER
C8, C9	2	10 μF, 25 V	Taiyo Yuden	TMK325BJ106MM
C10	4	47 μF, 6.3 V	TDK	C2012X5R0J476M
L1	1	1 μH, 18.5 A, 2.3 mΩ	NEC Tokin	MPC1055L1R0C
Q1	1	30 V, 35 A, 8.5 mΩ	Fairchild	FDMS8680
Q2	1	30 V, 42 A, 3.5 mΩ	Fairchild	FDMS8670AS



## Layout Considerations

Certain issues must be considered before designing a layout using the TPS51916.

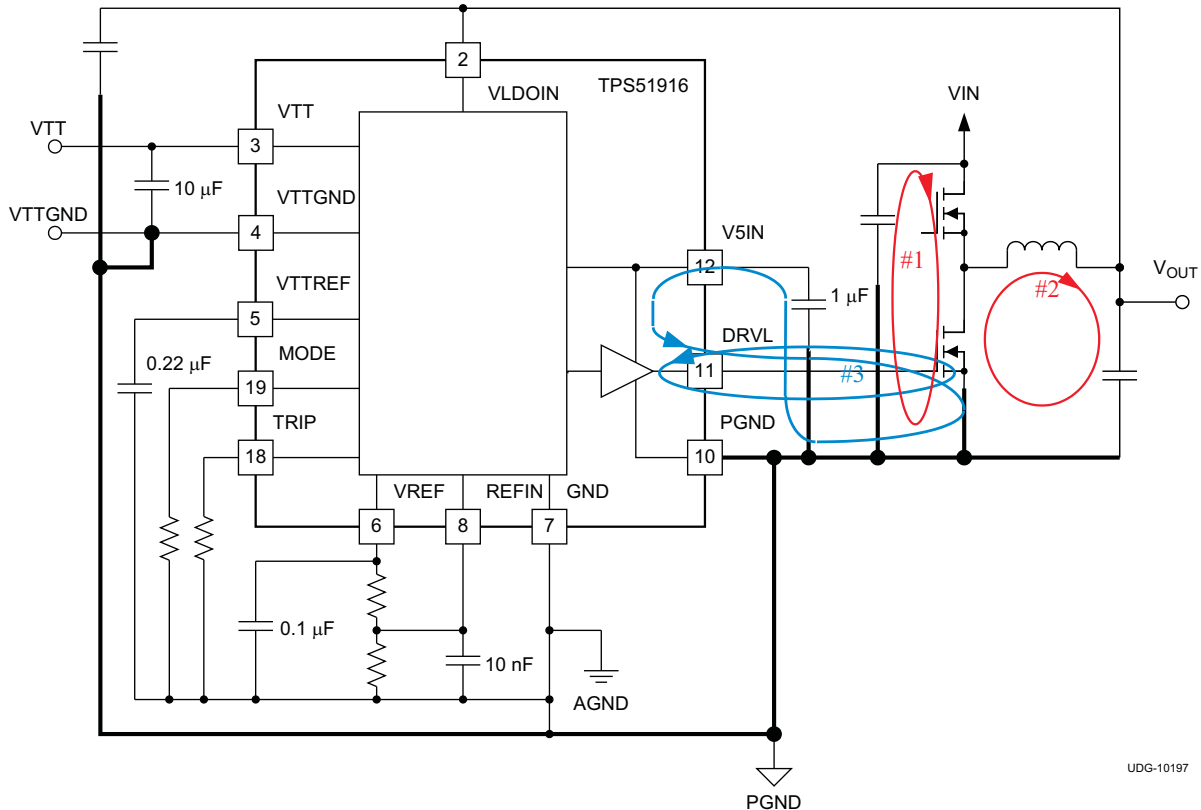

Figure 41. DC/DC Converter Ground System

- VIN capacitor(s), VOUT capacitor(s) and MOSFETs are the power components and should be placed on one side of the PCB (solder side). Other small signal components should be placed on another side (component side). At least one inner system GND plane should be inserted, in order to shield and isolate the small signal traces from noisy power lines.
- All sensitive analog traces and components such as VDDQSNS, VTTSNS, MODE, REFIN, VREF and TRIP should be placed away from high-voltage switching nodes such as SW, DRVL, DRVH or VBST to avoid coupling. Use internal layer(s) as system GND plane(s) and shield feedback trace from power traces and components.
- The DC/DC converter has several high-current loops. The area of these loops should be minimized in order to suppress generating switching noise.
  - The most important loop to minimize the area of is the path from the VIN capacitor(s) through the high and low-side MOSFETs, and back to the negative node of the VIN capacitor(s). Connect the negative node of the VIN capacitor(s) and the source of the low-side MOSFET as close as possible. (Refer to loop #1 of Figure 41)
  - The second important loop is the path from the low-side MOSFET through inductor and VOUT capacitor(s), and back to source of the low-side MOSFET. Connect the source of the low-side MOSFET and negative node of VOUT capacitor(s) as close as possible. (Refer to loop #2 of Figure 41)
  - The third important loop is of gate driving system for the low-side MOSFET. To turn on the low-side MOSFET, high current flows from V5IN capacitor through gate driver and the low-side MOSFET, and back to negative node of the capacitor. To turn off the low-side MOSFET, high current flows from gate of the low-side MOSFET through the gate driver and PGND pin, and back to source of the low-side MOSFET. Connect negative node of V5IN capacitor, source of the low-side MOSFET and PGND pin as close as possible. (Refer to loop #3 of Figure 41)
- Connect negative nodes of the VTTREF output capacitor, VREF capacitor and REFIN capacitor and bottom-side resistance of VREF voltage-divider to GND pin as close as possible. The negative node of the VTT

output capacitor(s), VTTGND, GND and PGND pins should be connected to system GND plane near the device as shown in [Figure 41](#).

- Because the TPS51916 controls output voltage referring to voltage across VOUT capacitor, VDDQSNS should be connected to the positive node of VOUT capacitor using different trace from that for VLDOIN. Remember that this sensing potential is the reference voltage of VTTREF. Avoid any noise generative lines. GND pin refers to the negative node of VOUT capacitor.
- Connect the overcurrent setting resistor from TRIP pin to GND pin and make the connections as close as possible to the device to avoid coupling from a high-voltage switching node.
- Connect the frequency and mode setting resistor from MODE pin to GND pin ground, and make the connections as close as possible to the device to avoid coupling from a high-voltage switching node.
- Connections from gate drivers to the respective gate of the high-side or the low-side MOSFET should be as short as possible to reduce stray inductance. Use 0.65 mm (25 mils) or wider trace and via(s) of at least 0.5 mm (20 mils) diameter along this trace.
- The PCB trace defined as SW node, which connects to the source of the high-side MOSFET, the drain of the low-side MOSFET and the high-voltage side of the inductor, should be as short and wide as possible.
- VLDOIN should be connected to VOUT with short and wide traces. An input bypass capacitor should be placed as close as possible to the pin with short and wide connections. The negative node of the capacitor should be connected to system GND plane.
- The output capacitor for VTT should be placed close to the pins with a short and wide connection in order to avoid additional ESR and/or ESL of the trace.
- VTTSNS should be connected to the positive node of the VTT output capacitor(s) using a separate trace from the high-current power line. When remote sensing is required attach the output capacitor(s) at that point. Also, it is recommended to minimize any additional ESR and/or ESL of ground trace between GND pin and the output capacitor(s).
- Consider adding a low pass filter (LPF) at VTTSNS in case the ESR of the VTT output capacitor(s) is larger than 2 m $\Omega$ .
- In order to effectively remove heat from the package, prepare a thermal land and solder to the package thermal pad. Wide trace of the component-side copper, connected to this thermal land, helps heat spreading. Numerous vias with a 0.3-mm diameter connected from the thermal land to the internal/solder-side ground plane(s) should be used to help dissipation. The thermal land can be connected to either AGND or PGND but is recommended to be connected to PGND, the system GND plane(s), which has better heat radiation.

---

<b>Changes from Revision B (AUGUST 2011) to Revision D</b>	<b>Page</b>
• Added clarity to <a href="#">FUNCTIONAL BLOCK DIAGRAM</a> .....	<b>8</b>
• Added clarity to <a href="#">Figure 37</a> .....	<b>19</b>
• Added more information to <a href="#">VTT and VTTREF</a> section. ....	<b>20</b>

---

**PACKAGING INFORMATION**

Orderable Device	Status <sup>(1)</sup>	Package Type	Package Drawing	Pins	Package Qty	Eco Plan <sup>(2)</sup>	Lead/ Ball Finish	MSL Peak Temp <sup>(3)</sup>	Samples (Requires Login)
TPS51916RUKR	ACTIVE	WQFN	RUK	20	3000	Green (RoHS & no Sb/Br)	CU NIPDAU	Level-2-260C-1 YEAR	
TPS51916RUKT	ACTIVE	WQFN	RUK	20	250	Green (RoHS & no Sb/Br)	CU NIPDAU	Level-2-260C-1 YEAR	

<sup>(1)</sup> The marketing status values are defined as follows:

**ACTIVE:** Product device recommended for new designs.

**LIFEBUY:** TI has announced that the device will be discontinued, and a lifetime-buy period is in effect.

**NRND:** Not recommended for new designs. Device is in production to support existing customers, but TI does not recommend using this part in a new design.

**PREVIEW:** Device has been announced but is not in production. Samples may or may not be available.

**OBsolete:** TI has discontinued the production of the device.

<sup>(2)</sup> Eco Plan - The planned eco-friendly classification: Pb-Free (RoHS), Pb-Free (RoHS Exempt), or Green (RoHS & no Sb/Br) - please check <http://www.ti.com/productcontent> for the latest availability information and additional product content details.

**TBD:** The Pb-Free/Green conversion plan has not been defined.

**Pb-Free (RoHS):** TI's terms "Lead-Free" or "Pb-Free" mean semiconductor products that are compatible with the current RoHS requirements for all 6 substances, including the requirement that lead not exceed 0.1% by weight in homogeneous materials. Where designed to be soldered at high temperatures, TI Pb-Free products are suitable for use in specified lead-free processes.

**Pb-Free (RoHS Exempt):** This component has a RoHS exemption for either 1) lead-based flip-chip solder bumps used between the die and package, or 2) lead-based die adhesive used between the die and leadframe. The component is otherwise considered Pb-Free (RoHS compatible) as defined above.

**Green (RoHS & no Sb/Br):** TI defines "Green" to mean Pb-Free (RoHS compatible), and free of Bromine (Br) and Antimony (Sb) based flame retardants (Br or Sb do not exceed 0.1% by weight in homogeneous material)

<sup>(3)</sup> MSL, Peak Temp. -- The Moisture Sensitivity Level rating according to the JEDEC industry standard classifications, and peak solder temperature.

**Important Information and Disclaimer:** The information provided on this page represents TI's knowledge and belief as of the date that it is provided. TI bases its knowledge and belief on information provided by third parties, and makes no representation or warranty as to the accuracy of such information. Efforts are underway to better integrate information from third parties. TI has taken and continues to take reasonable steps to provide representative and accurate information but may not have conducted destructive testing or chemical analysis on incoming materials and chemicals. TI and TI suppliers consider certain information to be proprietary, and thus CAS numbers and other limited information may not be available for release.

In no event shall TI's liability arising out of such information exceed the total purchase price of the TI part(s) at issue in this document sold by TI to Customer on an annual basis.

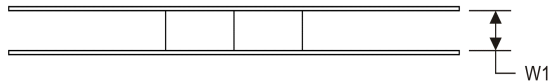
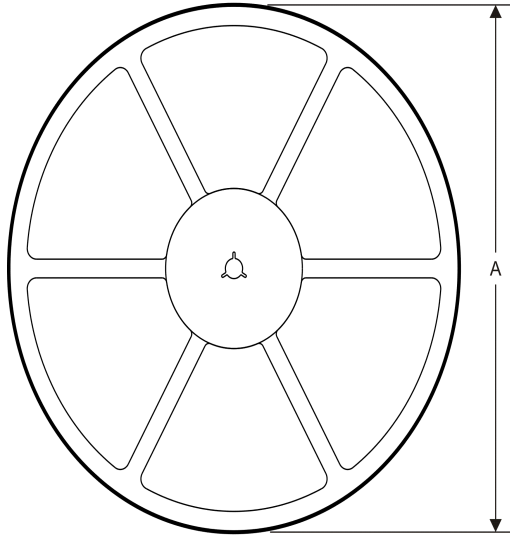
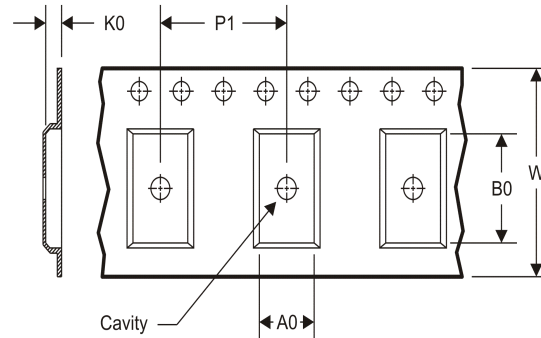
**TAPE AND REEL INFORMATION**
**REEL DIMENSIONS**

**TAPE DIMENSIONS**

A0	Dimension designed to accommodate the component width
B0	Dimension designed to accommodate the component length
K0	Dimension designed to accommodate the component thickness
W	Overall width of the carrier tape
P1	Pitch between successive cavity centers

**TAPE AND REEL INFORMATION**

\*All dimensions are nominal

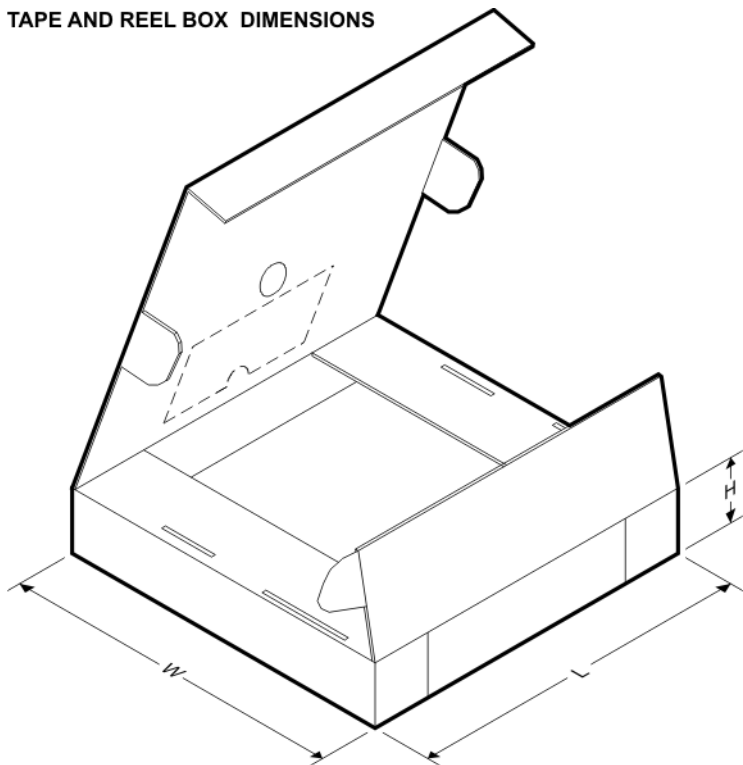
Device	Package Type	Package Drawing	Pins	SPQ	Reel Diameter (mm)	Reel Width W1 (mm)	A0 (mm)	B0 (mm)	K0 (mm)	P1 (mm)	W (mm)	Pin1 Quadrant
TPS51916RUKR	WQFN	RUK	20	3000	330.0	12.4	3.3	3.3	1.1	8.0	12.0	Q2
TPS51916RUKT	WQFN	RUK	20	250	180.0	12.4	3.3	3.3	1.1	8.0	12.0	Q2

**TAPE AND REEL BOX DIMENSIONS**

\*All dimensions are nominal

Device	Package Type	Package Drawing	Pins	SPQ	Length (mm)	Width (mm)	Height (mm)
TPS51916RUKR	WQFN	RUK	20	3000	367.0	367.0	35.0
TPS51916RUKT	WQFN	RUK	20	250	210.0	185.0	35.0

RUK (S-PWQFN-N20)

PLASTIC QUAD FLATPACK NO-LEAD

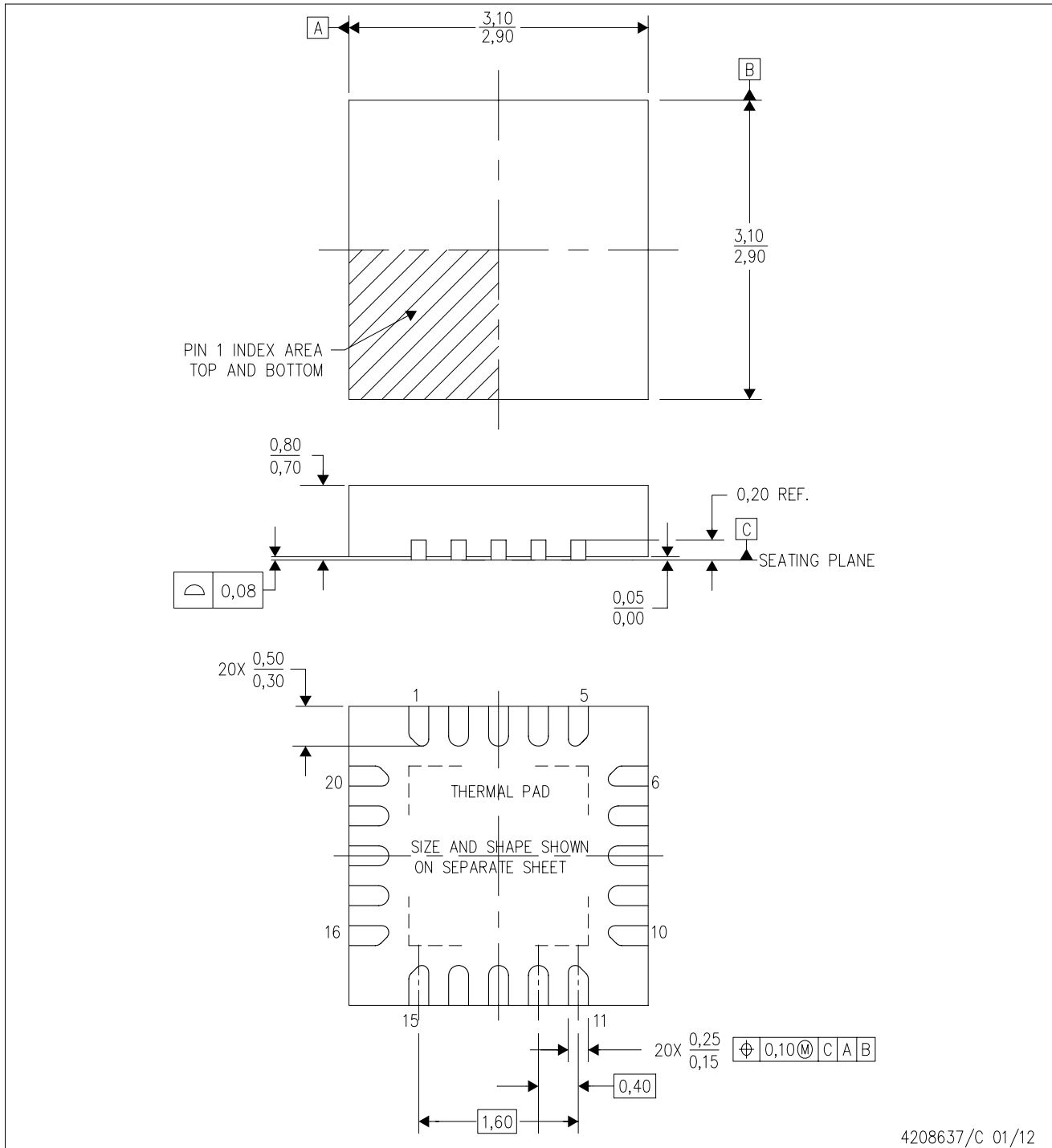

4208637/C 01/12

- NOTES:
- All linear dimensions are in millimeters. Dimensioning and tolerancing per ASME Y14.5M-1994.
  - This drawing is subject to change without notice.
  - Quad Flatpack, No-leads (QFN) package configuration.
  - The package thermal pad must be soldered to the board for thermal and mechanical performance.
  - See the additional figure in the Product Data Sheet for details regarding the exposed thermal pad features and dimensions.
  - Falls within JEDEC MO-220.

# THERMAL PAD MECHANICAL DATA

RUUK (S-PWQFN-N20)

PLASTIC QUAD FLATPACK NO-LEAD

## THERMAL INFORMATION

This package incorporates an exposed thermal pad that is designed to be attached directly to an external heatsink. The thermal pad must be soldered directly to the printed circuit board (PCB). After soldering, the PCB can be used as a heatsink. In addition, through the use of thermal vias, the thermal pad can be attached directly to the appropriate copper plane shown in the electrical schematic for the device, or alternatively, can be attached to a special heatsink structure designed into the PCB. This design optimizes the heat transfer from the integrated circuit (IC).

For information on the Quad Flatpack No-Lead (QFN) package and its advantages, refer to Application Report, QFN/SON PCB Attachment, Texas Instruments Literature No. SLUA271. This document is available at [www.ti.com](http://www.ti.com).

The exposed thermal pad dimensions for this package are shown in the following illustration.

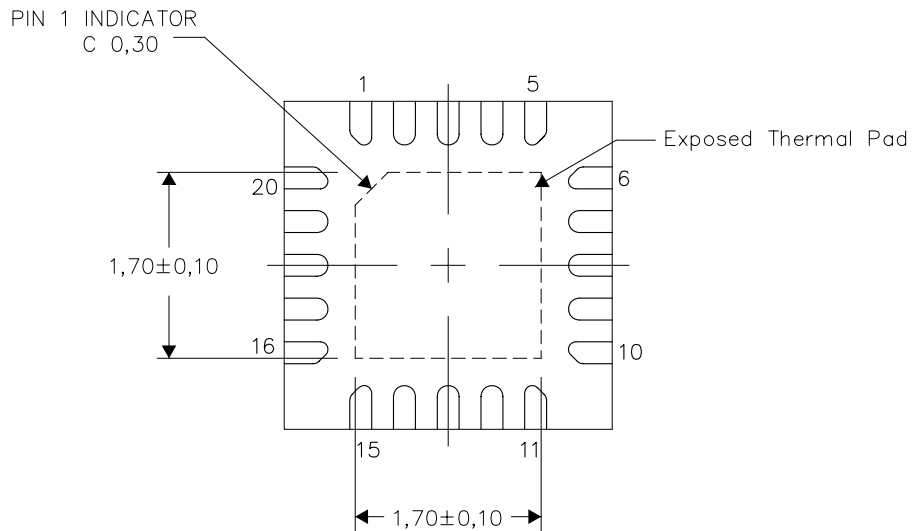

Exposed Thermal Pad Dimensions

4209762/D 03/12

NOTE: All linear dimensions are in millimeters



RUK (S-PWQFN-N20)

PLASTIC QUAD FLATPACK NO-LEAD

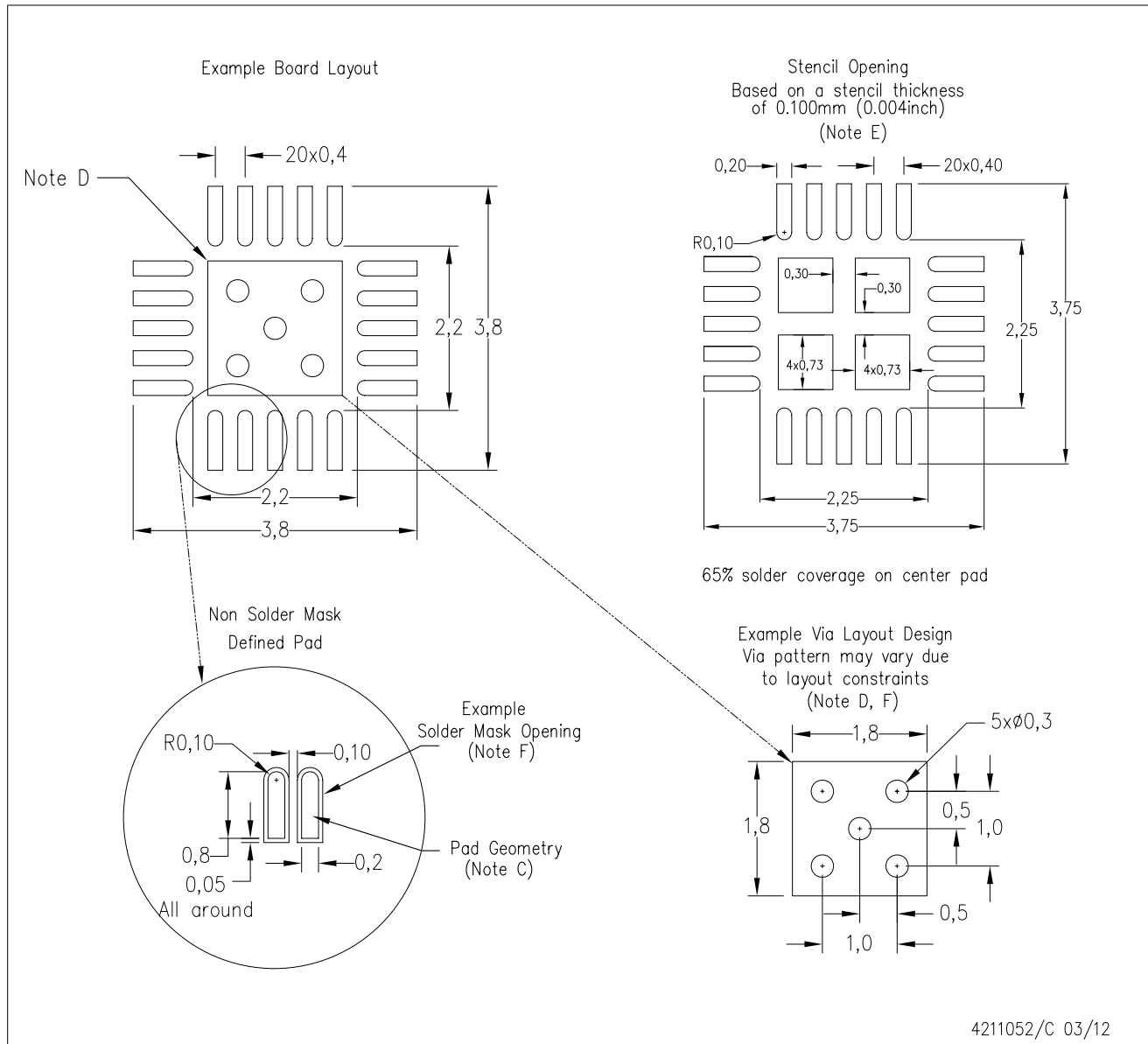

- NOTES:
- All linear dimensions are in millimeters.
  - This drawing is subject to change without notice.
  - Publication IPC-7351 is recommended for alternate designs.
  - This package is designed to be soldered to a thermal pad on the board. Refer to Application Note, Quad Flat-Pack Packages, Texas Instruments Literature No. SLUA271, and also the Product Data Sheets for specific thermal information, via requirements, and recommended board layout. These documents are available at [www.ti.com](http://www.ti.com) <<http://www.ti.com>>.
  - Laser cutting apertures with trapezoidal walls and also rounding corners will offer better paste release. Customers should contact their board assembly site for stencil design recommendations. Refer to IPC 7525 for stencil design considerations.
  - Customers should contact their board fabrication site for minimum solder mask web tolerances between signal pads.

## IMPORTANT NOTICE

Texas Instruments Incorporated and its subsidiaries (TI) reserve the right to make corrections, enhancements, improvements and other changes to its semiconductor products and services per JESD46C and to discontinue any product or service per JESD48B. Buyers should obtain the latest relevant information before placing orders and should verify that such information is current and complete. All semiconductor products (also referred to herein as "components") are sold subject to TI's terms and conditions of sale supplied at the time of order acknowledgment.

TI warrants performance of its components to the specifications applicable at the time of sale, in accordance with the warranty in TI's terms and conditions of sale of semiconductor products. Testing and other quality control techniques are used to the extent TI deems necessary to support this warranty. Except where mandated by applicable law, testing of all parameters of each component is not necessarily performed.

TI assumes no liability for applications assistance or the design of Buyers' products. Buyers are responsible for their products and applications using TI components. To minimize the risks associated with Buyers' products and applications, Buyers should provide adequate design and operating safeguards.

TI does not warrant or represent that any license, either express or implied, is granted under any patent right, copyright, mask work right, or other intellectual property right relating to any combination, machine, or process in which TI components or services are used. Information published by TI regarding third-party products or services does not constitute a license to use such products or services or a warranty or endorsement thereof. Use of such information may require a license from a third party under the patents or other intellectual property of the third party, or a license from TI under the patents or other intellectual property of TI.

Reproduction of significant portions of TI information in TI data books or data sheets is permissible only if reproduction is without alteration and is accompanied by all associated warranties, conditions, limitations, and notices. TI is not responsible or liable for such altered documentation. Information of third parties may be subject to additional restrictions.

Resale of TI components or services with statements different from or beyond the parameters stated by TI for that component or service voids all express and any implied warranties for the associated TI component or service and is an unfair and deceptive business practice. TI is not responsible or liable for any such statements.

Buyer acknowledges and agrees that it is solely responsible for compliance with all legal, regulatory and safety-related requirements concerning its products, and any use of TI components in its applications, notwithstanding any applications-related information or support that may be provided by TI. Buyer represents and agrees that it has all the necessary expertise to create and implement safeguards which anticipate dangerous consequences of failures, monitor failures and their consequences, lessen the likelihood of failures that might cause harm and take appropriate remedial actions. Buyer will fully indemnify TI and its representatives against any damages arising out of the use of any TI components in safety-critical applications.

In some cases, TI components may be promoted specifically to facilitate safety-related applications. With such components, TI's goal is to help enable customers to design and create their own end-product solutions that meet applicable functional safety standards and requirements. Nonetheless, such components are subject to these terms.

No TI components are authorized for use in FDA Class III (or similar life-critical medical equipment) unless authorized officers of the parties have executed a special agreement specifically governing such use.

Only those TI components which TI has specifically designated as military grade or "enhanced plastic" are designed and intended for use in military/aerospace applications or environments. Buyer acknowledges and agrees that any military or aerospace use of TI components which have **not** been so designated is solely at the Buyer's risk, and that Buyer is solely responsible for compliance with all legal and regulatory requirements in connection with such use.

TI has specifically designated certain components which meet ISO/TS16949 requirements, mainly for automotive use. Components which have not been so designated are neither designed nor intended for automotive use; and TI will not be responsible for any failure of such components to meet such requirements.

### Products

Audio	<a href="http://www.ti.com/audio">www.ti.com/audio</a>
Amplifiers	<a href="http://amplifier.ti.com">amplifier.ti.com</a>
Data Converters	<a href="http://dataconverter.ti.com">dataconverter.ti.com</a>
DLP® Products	<a href="http://www.dlp.com">www.dlp.com</a>
DSP	<a href="http://dsp.ti.com">dsp.ti.com</a>
Clocks and Timers	<a href="http://www.ti.com/clocks">www.ti.com/clocks</a>
Interface	<a href="http://interface.ti.com">interface.ti.com</a>
Logic	<a href="http://logic.ti.com">logic.ti.com</a>
Power Mgmt	<a href="http://power.ti.com">power.ti.com</a>
Microcontrollers	<a href="http://microcontroller.ti.com">microcontroller.ti.com</a>
RFID	<a href="http://www.ti-rfid.com">www.ti-rfid.com</a>
OMAP Mobile Processors	<a href="http://www.ti.com/omap">www.ti.com/omap</a>
Wireless Connectivity	<a href="http://www.ti.com/wirelessconnectivity">www.ti.com/wirelessconnectivity</a>

### Applications

Automotive and Transportation	<a href="http://www.ti.com/automotive">www.ti.com/automotive</a>
Communications and Telecom	<a href="http://www.ti.com/communications">www.ti.com/communications</a>
Computers and Peripherals	<a href="http://www.ti.com/computers">www.ti.com/computers</a>
Consumer Electronics	<a href="http://www.ti.com/consumer-apps">www.ti.com/consumer-apps</a>
Energy and Lighting	<a href="http://www.ti.com/energy">www.ti.com/energy</a>
Industrial	<a href="http://www.ti.com/industrial">www.ti.com/industrial</a>
Medical	<a href="http://www.ti.com/medical">www.ti.com/medical</a>
Security	<a href="http://www.ti.com/security">www.ti.com/security</a>
Space, Avionics and Defense	<a href="http://www.ti.com/space-avionics-defense">www.ti.com/space-avionics-defense</a>
Video and Imaging	<a href="http://www.ti.com/video">www.ti.com/video</a>

**TI E2E Community** [e2e.ti.com](http://e2e.ti.com)