

Synchronous Buck FET Driver Optimized for High-Frequency Applications

Check for Samples: [TPS51604](#)

FEATURES

- Reduced Dead-Time Drive Circuit for Optimized CCM
- Automatic Zero Crossing Detection for Optimized DCM Efficiency
- Multiple Low-Power Modes for Optimized Light-Load Efficiency
- Optimized Signal Path Delays for High-Frequency Operation
- Integrated BST Switch Drive Strength Optimized for Ultrabook FETs
- Optimized for 5-V FET Drive
- Conversion Input Voltage Range (V_{IN}): 4.5 V to 28 V
- Small, 2 mm x 2 mm, 8-Pin, SON Power Pad Package

APPLICATIONS

- High Frequency CPU V_{CORE} Applications Powered By:
 - Adapter
 - Battery
 - NVDC
 - 5-V or 12-V Rails

DESCRIPTION

The TPS51604 drivers are optimized for high-frequency CPU V_{CORE} applications. Advanced features such as reduced dead-time drive and Auto Zero Crossing are used to optimize efficiency over the entire load range.

The \overline{SKIP} pin provides immediate CCM operation to support controlled management of the output voltage. In addition, the TPS51604 supports two low-power modes. With the PWM input in tri-state, quiescent current is reduced to 130 μA , with immediate response. When \overline{SKIP} is held at tri-state, the current is reduced to 8 μA (typically 20 μs is required to resume switching). Paired with the appropriate TI controller, the drivers deliver an exceptionally high performance power supply system.

The TPS51604 is packaged in a space saving, thermally enhanced 8-pin, 2 mm x 2 mm SON package and operates from -40°C to 105°C .

TYPICAL APPLICATION

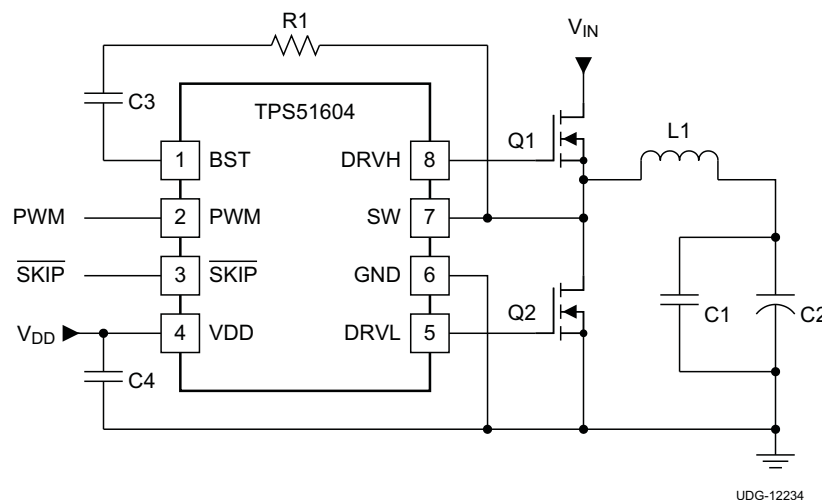

Please be aware that an important notice concerning availability, standard warranty, and use in critical applications of Texas Instruments semiconductor products and disclaimers thereto appears at the end of this data sheet.



These devices have limited built-in ESD protection. The leads should be shorted together or the device placed in conductive foam during storage or handling to prevent electrostatic damage to the MOS gates.

ORDERING INFORMATION^{(1) (2)}

T _A	PACKAGE	PART NUMBER	PINS	OUTPUT SUPPLY	MIN. QUANTITY	ECO PLAN
-40°C to 105°C	Plastic Small Outline No-Lead (SON)	TPS51604DSGT	8	Tape-and-reel	250	Green (RoHS and no Sb/Br)
		TPS51604DSGR			3000	

- (1) For the most current package and ordering information, see the Package Option Addendum at the end of this document, or visit the TI website at www.ti.com.
- (2) Package drawings, standard packing quantities, thermal data, symbolization, and PCB design guidelines are available at www.ti.com/sc/package.

ABSOLUTE MAXIMUM RATINGS^{(1) (2)}

over operating free-air temperature range (unless otherwise noted)

		MIN	MAX	UNIT
Input voltage	VDD	-0.3	6	V
	PWM, SKIP	-0.3	6	
Output voltage	BST	-0.3	35	V
	BST (transient < 20 ns)	-0.3	38	
	BST to SW; DRVH to SW	-0.3	6	
	SW	-2	30	
	DRVH, SW (transient < 20 ns)	-5	38	
	DRVL	-0.3	6	
Ground pins	GND to PAD	-0.3	0.3	V
Operating junction temperature, T _J		-40	125	°C
Storage temperature, T _{stg}		-55	150	°C

- (1) Stresses beyond those listed under "absolute maximum ratings" may cause permanent damage to the device. These are stress ratings only and functional operation of the device at these or any other conditions beyond those indicated under "recommended operating conditions" is not implied. Exposure to absolute-maximum-rated conditions for extended periods may affect device reliability.
- (2) All voltage values are with respect to the network ground terminal unless otherwise noted.

THERMAL INFORMATION

THERMAL METRIC ⁽¹⁾		TPS51604	UNITS
		SON (DSG) (8 PINS)	
θ _{JA}	Junction-to-ambient thermal resistance	63.1	°C/W
θ _{JCtop}	Junction-to-case (top) thermal resistance	74.1	
θ _{JB}	Junction-to-board thermal resistance	34.3	
ψ _{JT}	Junction-to-top characterization parameter	2.0	
ψ _{JB}	Junction-to-board characterization parameter	34.9	
θ _{JCbot}	Junction-to-case (bottom) thermal resistance	11.7	

- (1) For more information about traditional and new thermal metrics, see the *IC Package Thermal Metrics* application report, SPRA953.

RECOMMENDED OPERATING CONDITIONS

over operating free-air temperature range (unless otherwise noted)

		MIN	TYP	MAX	UNIT
Input voltage	VDD	4.5	5.0	5.5	V
	PWM, $\overline{\text{SKIP}}$	-0.1		5.5	
Output voltage	BST	-0.1		34	V
	BST to SW; DRVH to SW	-0.1		5.5	
	SW	-1.0		28	
	DRVL	-0.1		5.5	
Ground pins	GND to PAD	-0.1		0.1	V
Operating junction temperature, T _J		-40		105	°C

ELECTRICAL CHARACTERISTICS

These specifications apply for $T_J = -40^{\circ}\text{C}$ to 105°C and $V_{DD} = 5.0\text{V}$ unless otherwise specified.

PARAMETER		CONDITIONS	MIN	TYP	MAX	UNITS
VDD INPUT SUPPLY						
I_{CC}	Supply current (operating)	$V_{SKIP} = V_{VDD}$ or $V_{SKIP} = 0\text{V}$, PWM = High		160	600	μA
		$V_{SKIP} = V_{VDD}$ or $V_{SKIP} = 0\text{V}$, PWM = Low		250		
		$V_{SKIP} = V_{VDD}$ or $V_{SKIP} = 0\text{V}$, PWM = Float		130		
		$V_{SKIP} = \text{Float}$		8		
VDD UNDERVOLTAGE LOCKOUT (UVLO)						
V_{UVLO}	UVLO threshold	Rising threshold			4.15	V
		Falling threshold	3.7			
V_{UVHYS}	UVLO hysteresis			0.2		V
PWM AND SKIP I/O SPECIFICATIONS						
R_I	Input impedance	Pull up to VDD		1.7		$\text{M}\Omega$
		Pull down (to GND)		800		$\text{k}\Omega$
V_{IL}	Low-level input voltage				0.6	V
V_{IH}	High-level input voltage		2.65			
V_{IHH}	Hysteresis			0.2		
V_{TS}	Tri-state voltage		1.3		2.0	
$t_{THOLD(off1)}$	Tri-state activation time (falling) PWM			60		ns
$t_{THOLD(off2)}$	Tri-state activation time (rising) PWM			60		
t_{TSKF}	Tri-state activation time (falling) SKIP			1		μs
t_{TSKR}	Tri-state activation time (rising) SKIP			1		
$t_{3RD(PWM)}$	Tri-state exit time PWM				100	ns
$t_{3RD(SKIP)}$	Tri-state exit time SKIP				50	μs
HIGH-SIDE GATE DRIVER (DRVH)						
$t_{R(DRVH)}$	Rise time	DRVH rising, $C_{DRVH} = 3.3\text{ nF}$; 20% to 80%		30		ns
$t_{RPD(DRVH)}$	Rise time propagation delay	$C_{DRVH} = 3.3\text{ nF}$		40		ns
R_{SRC}	Source resistance	Source resistance, $(V_{BST} - V_{SW}) = 5\text{ V}$, high state, $(V_{BST} - V_{DRVH}) = 0.1\text{ V}$		4	8	Ω
$t_{F(DRVH)}$	Fall time	DRVH falling, $C_{DRVH} = 3.3\text{ nF}$		8		ns
$t_{FPD(DRVH)}$	Fall-time propagation delay	$C_{DRVH} = 3.3\text{ nF}$		25		ns
R_{SNK}	Sink resistance	Sink resistance, $(V_{BST} - V_{SW})$ forced to 5 V, low state $(V_{DRVH} - V_{SW}) = 0.1\text{ V}$		0.5	1.6	Ω
R_{DRVH}	DRVH to SW resistance ⁽¹⁾			100		$\text{k}\Omega$
LOW-SIDE GATE DRIVER (DRVL)						
$t_{R(DRVL)}$	Rise time	DRVL rising, $C_{DRVL} = 3.3\text{ nF}$; 20% to 80%		15		ns
$t_{RPD(DRVL)}$	Rise time propagation delay	$C_{DRVL} = 3.3\text{ nF}$		35		ns
R_{SRC}	Source resistance	Source resistance, $(V_{VDD} - \text{GND}) = 5\text{ V}$, high state, $(V_{VDD} - V_{DRVL}) = 0.1\text{ V}$		1.5	3	Ω
$t_{F(DRVL)}$	Fall time	DRVL falling, $C_{DRVL} = 3.3\text{ nF}$		10		ns
$t_{FPD(DRVL)}$	Fall-time propagation delay	$C_{DRVL} = 3.3\text{ nF}$		15		ns
R_{SNK}	Sink resistance	Sink resistance, $(V_{VDD} - \text{GND}) = 5\text{ V}$, low state, $(V_{DRVL} - \text{GND}) = 0.1\text{ V}$		0.4	1.6	Ω
R_{DRVL}	DRVL to GND resistance ⁽¹⁾			100		$\text{k}\Omega$

(1) Specified by design. Not production tested.

ELECTRICAL CHARACTERISTICS (continued)

These specifications apply for $T_j = -40^{\circ}\text{C}$ to 105°C and $V_{DD} = 5.0\text{V}$ unless otherwise specified.

PARAMETER	CONDITIONS	MIN	TYP	MAX	UNITS		
GATE DRIVER DEAD-TIME							
$t_{R(DT)}$	Rising edge	0	20	35	ns		
$t_{F(DT)}$	Falling edge	0	10	25	ns		
ZERO CROSSING COMPARATOR							
V_{ZX}	Zero crossing offset	SW voltage rising		-2.25	0	2.00	mV
BOOTSTRAP SWITCH							
V_{FBST}	Forward voltage	$I_F = 10\text{ mA}$		120	240	mV	
I_{RLEAK}	Reverse leakage	$(V_{BST} - V_{VDD}) = 25\text{ V}$				2	μA
$R_{DS(on)}$	On-resistance			12	24	Ω	

DEVICE INFORMATION

Functional Block Diagram

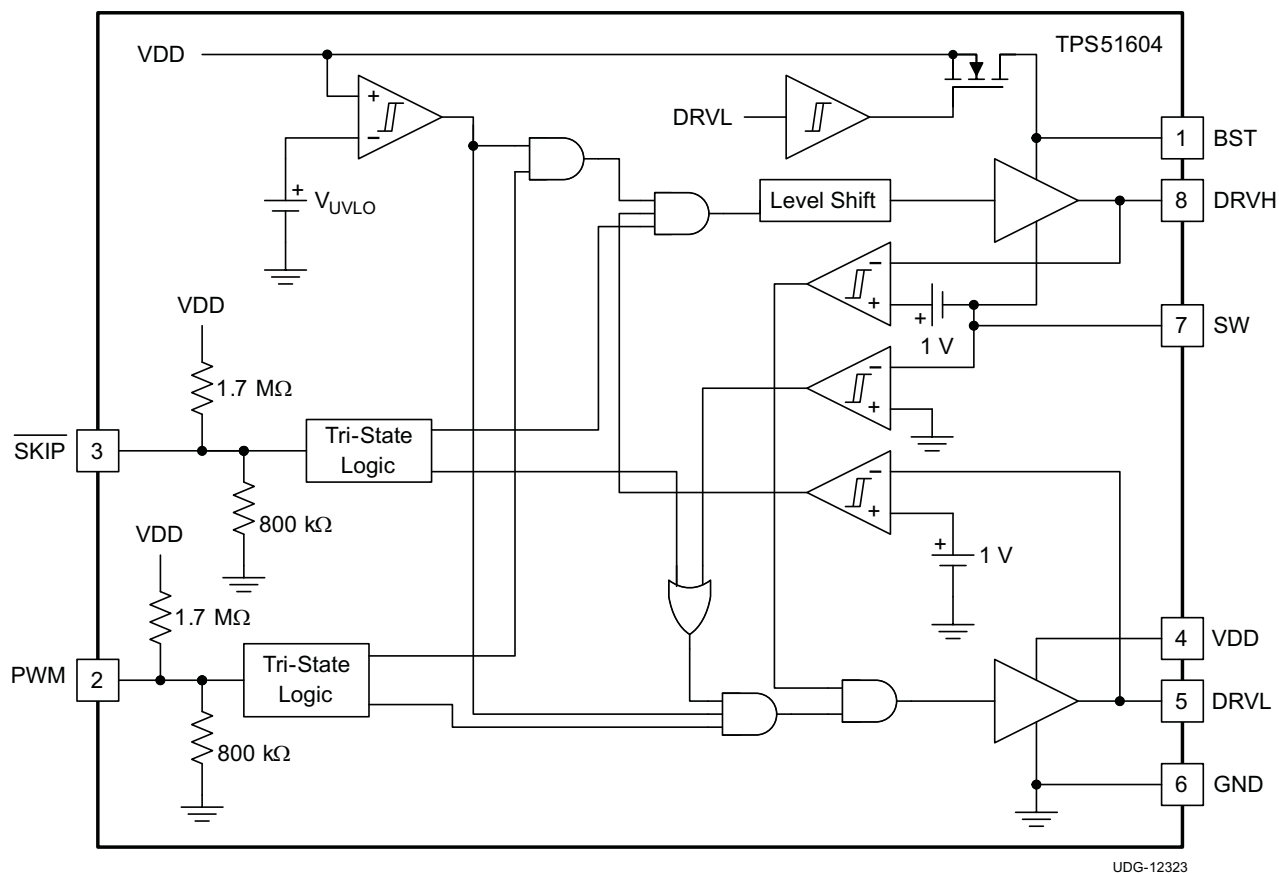

UDG-12323

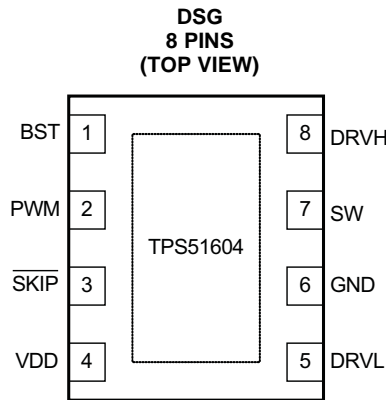

PIN FUNCTIONS

PIN		I/O ⁽¹⁾	DESCRIPTION
NAME	NO.		
BST	1	I	High-side N-channel FET bootstrap voltage input; power supply for high-side driver.
DRVH	8	O	High-side N-channel gate drive output.
DRVL	5	O	Synchronous low-side N-channel gate drive output
GND	6	–	Synchronous low-side N-channel gate drive return and IC reference.
PWM	2	I	PWM input. A tri-state voltage on this pin turns OFF both the high-side (DRVH) and low-side drivers (DRVL)
$\overline{\text{SKIP}}$	3	I	When $\overline{\text{SKIP}}$ is LO, the zero crossing comparator is active; the power chain enters discontinuous conduction mode when the inductor current reaches zero. When $\overline{\text{SKIP}}$ is HI, the zero crossing comparator is disabled, and the driver outputs follow the PWM input. A tri-state voltage on $\overline{\text{SKIP}}$ puts the driver into a very low power state.
SW	7	I/O	High-side N-channel gate drive return. Also, zero-crossing sense input.
VDD	4	I	5-V power supply input; decouple to GND with a ceramic capacitor with a value of 1 μF or greater.
Thermal Pad		–	Tie to system GND plane with multiple vias.

(1) I=Input, O=Output

TYPICAL CHARACTERISTICS

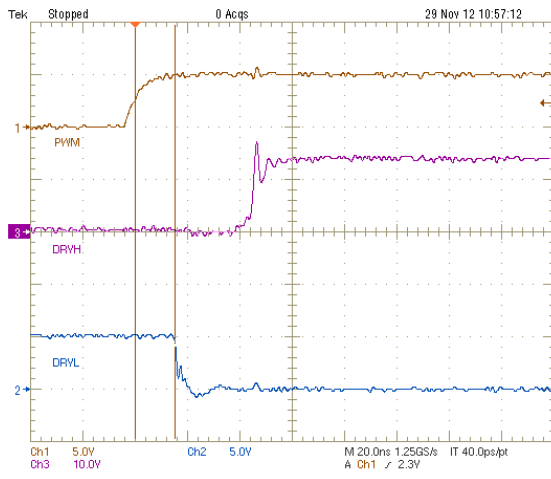

Figure 1. PWM High to DRVL Low

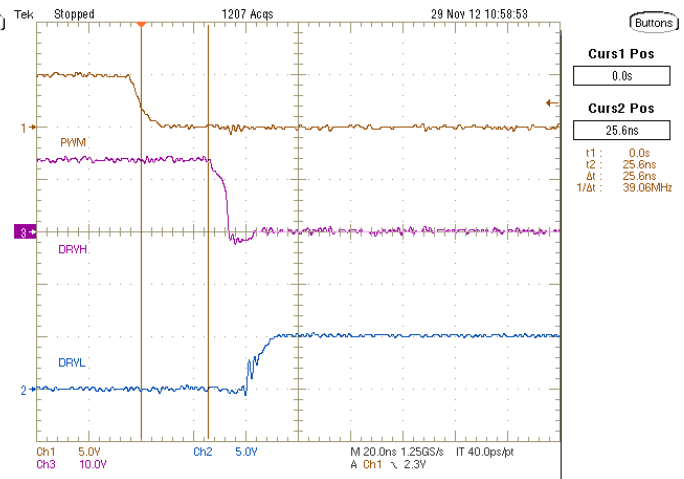

Figure 2. PWM Low to DRVH Low

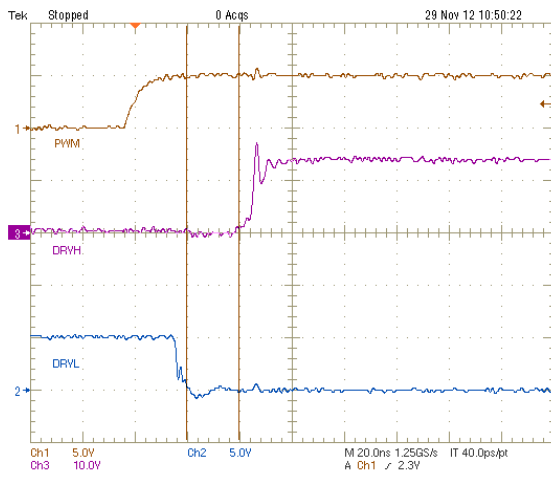

Figure 3. DRVL Low to DRVH High

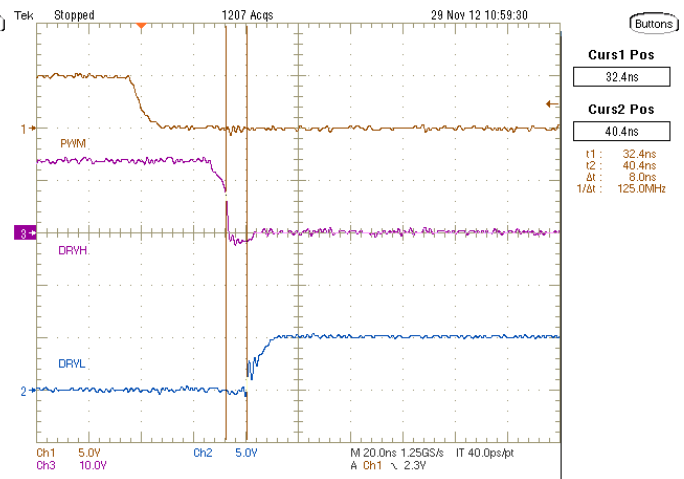

Figure 4. DRVH Low DRVL High

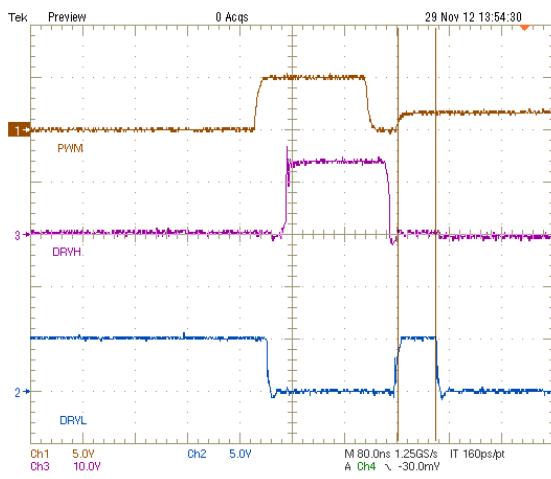

Figure 5. PWM Low to Tri-state

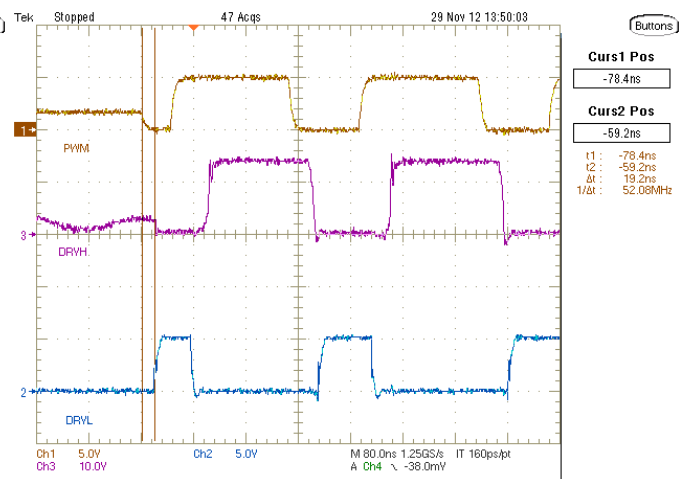

Figure 6. PWM Tri-State to Low

TYPICAL CHARACTERISTICS (continued)

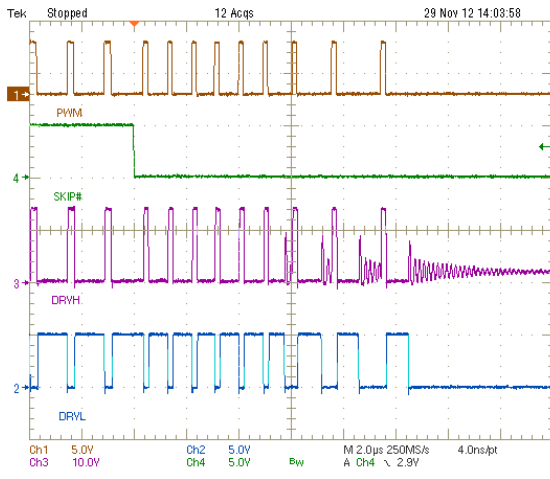

Figure 7. SKIP Mode Entry

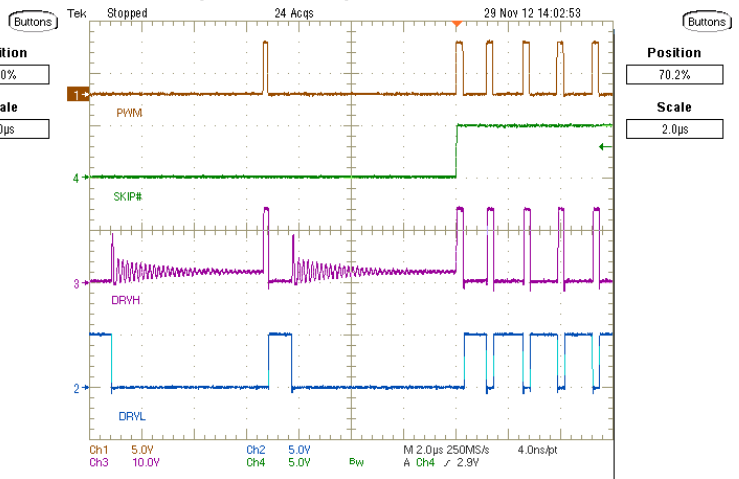

Figure 8. SKIP Mode Exit

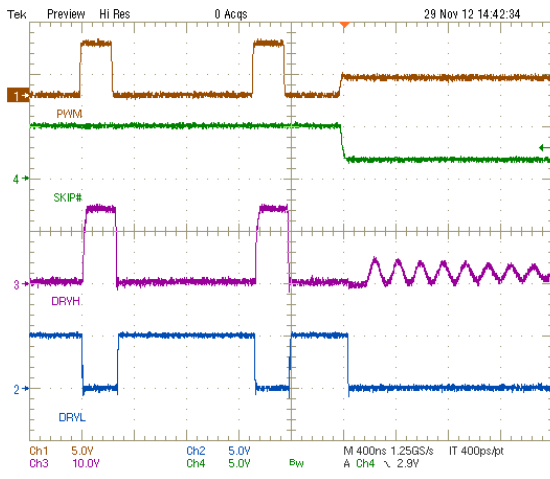

Figure 9. Very-Low-Power Mode Entry

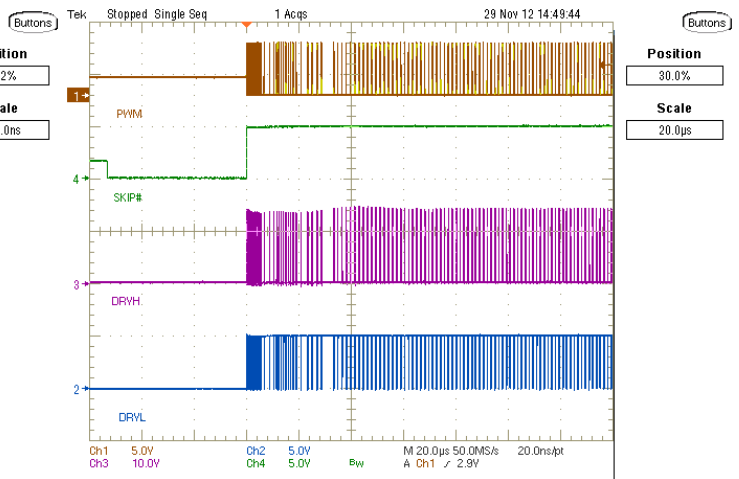

Figure 10. Very-Low-Power Mode Exit

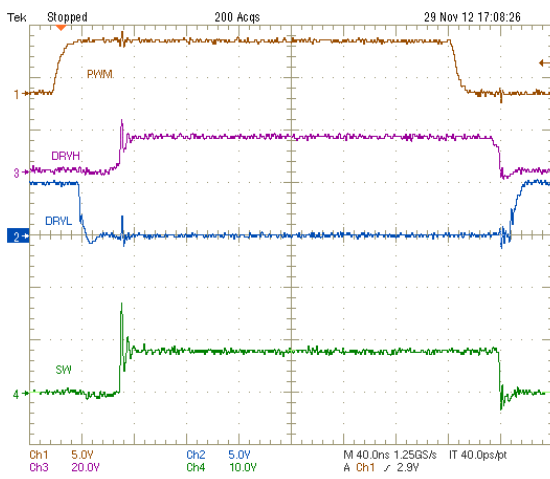

Figure 11. SW Node-Ringing at $V_{IN} = 8\text{ V}$

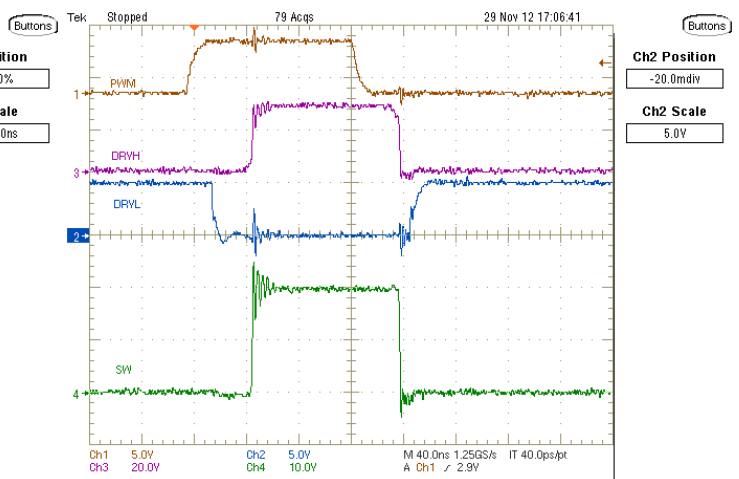

Figure 12. SW Node-Ringing at $V_{IN} = 20\text{ V}$

TYPICAL CHARACTERISTICS

Powerblock MOSFET: CSD87330(SLPS284) , Inductor: 0.22 μ F, 1.1 m Ω DCR

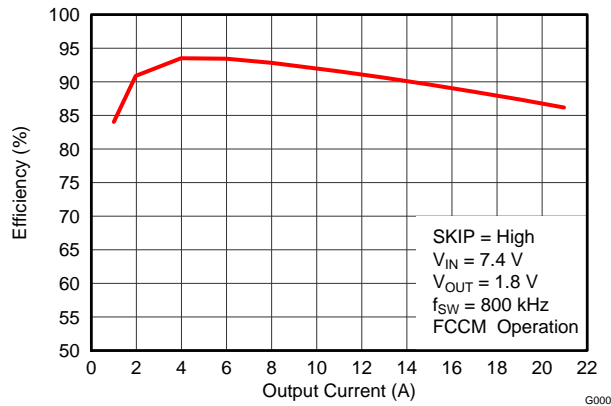

Figure 13. Efficiency vs. Output Current

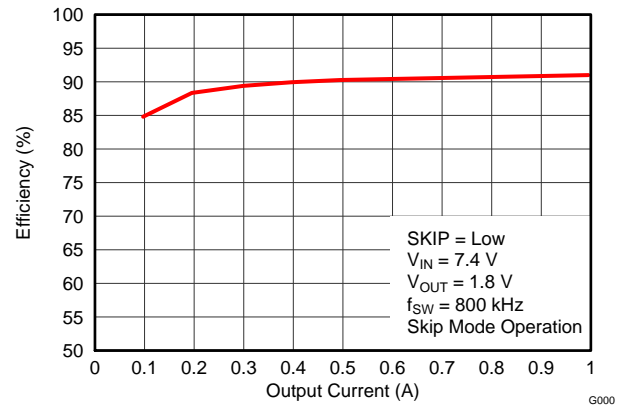

Figure 14. Efficiency vs. Output Current

DETAILED DESCRIPTION

The TPS51604 is a synchronous buck MOSFET driver designed to drive both high-side and low-side MOSFETs. It allows high-frequency operation with current driving capability matched to the application. The integrated boost switch is internal. The TPS51604 employs dead-time reduction control and shoot-through protection; which helps avoid simultaneous conduction of high-side and low-side MOSFETs. Also, the drivers improve light-load efficiency with integrated DCM mode operation using adaptive crossing detection. Typical applications yield a steady-state duty cycle of 60% or less. For high steady-state duty cycle applications, including a small external Schottky diode may help to ensure sufficient charging of the bootstrap capacitor.

Undervoltage Lockout Protection (UVLO)

The undervoltage lockout (UVLO) comparator evaluates the VDD voltage level. As V_{VDD} rises, both DRVH and DRV L hold actively low at all times until V_{VDD} reaches the higher UVLO threshold (V_{UVLO_H}). Then the driver becomes operational and responds to PWM and \overline{SKIP} commands. If VDD falls below the lower UVLO threshold ($V_{UVLO_L} = V_{UVLO_H} - \text{Hysteresis}$), the device disables the driver and drives the outputs of DRVH and DRV L actively low. [Figure 15](#) shows this function.

CAUTION

Do not start the driver in the very low power mode ($\overline{SKIP} = \text{Tri-state}$).

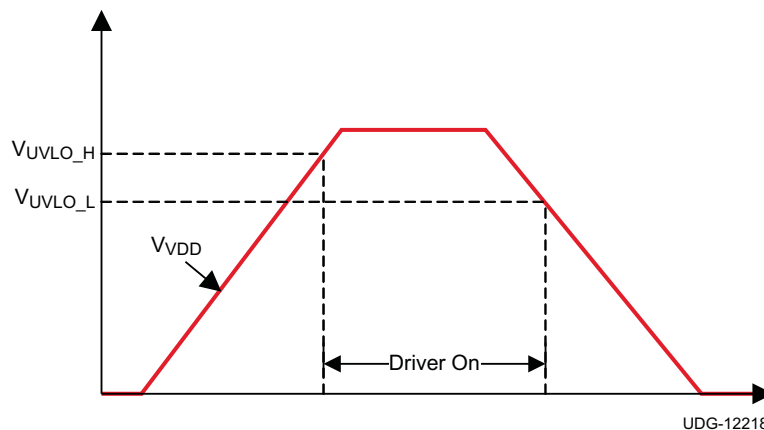

Figure 15. UVLO Operation

PWM Pin

The PWM pin incorporates an input tri-state function. The device forces the gate driver outputs to low when PWM is driven into the tri-state window and the driver enters a low power state with zero exit latency. The pin incorporates a weak pull-up to maintain the voltage within the tri-state window during low-power modes. Operation into and out of tri-state mode follows the timing diagram outlined in [Figure 16](#).

When VDD reaches the UVLO_H level, a tri-state voltage range (window) is set for the PWM input voltage. The window is defined the PWM voltage range between PWM logic high (V_{IH}) and logic low (V_{IL}) thresholds. The device sets high-level input voltage and low-level input voltage threshold levels to accommodate both 3.3 V (typ.) and 5.0 V (typ.) PWM drive signals.

When the PWM exits tri-state, the driver enters CCM for a period of 4 μs , regardless of the state of the \overline{SKIP} pin. Normal operation requires this time period in order for the auto-zero comparator to resume.

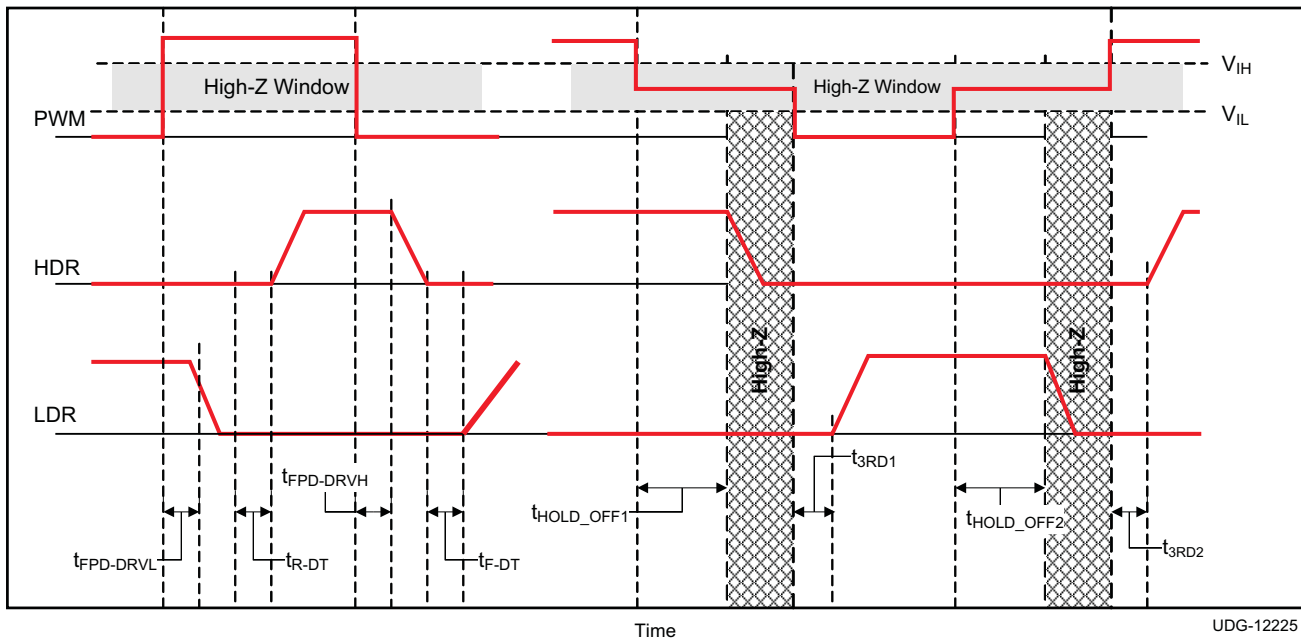

Figure 16. PWM Tri-State Timing Diagram

SKIP Pin

The $\overline{\text{SKIP}}$ pin incorporates the input tri-state buffer as PWM. The function is somewhat different. When $\overline{\text{SKIP}}$ is low, the zero crossing (ZX) detection comparator is enabled, and DCM mode operation occurs if the load current is less than the critical current. When $\overline{\text{SKIP}}$ is high, the ZX comparator disables, and the converter enters FCCM mode. When both $\overline{\text{SKIP}}$ and PWM are tri-stated, normal operation forces the gate driver outputs low and the driver enters a very-low-power state. In the low-power state, the UVLO comparator remains off to reduce quiescent current. When either $\overline{\text{SKIP}}$ is pulled low, the driver wakes up and is able to accept PWM pulses in less than 50 μs .

Table 1 shows the logic functions of UVLO, PWM, $\overline{\text{SKIP}}$ DRVH and DRVL.

Table 1. Logic Functions of the TPS51604

UVLO	PWM	$\overline{\text{SKIP}}$	DRVH	DRVL	MODE
Active	—	—	Low	Low	Disabled
Inactive	Low	Low	High ⁽¹⁾	Low	DCM ⁽¹⁾
Inactive	Low	High	High	Low	FCCM
Inactive	High	H or L	Low	High	
Inactive	Tri-state	H or L	Low	Low	Low power
Inactive	—	Tri-state	Low	Low	Very Low power

(1) Until zero crossing protection occurs.

Zero Crossing (ZX) Operation

The zero crossing comparator is adaptive for improved accuracy. As the output current decreases from a heavy load condition, the inductor current also reduces and eventually arrives at a valley, where it touches zero current, which is the boundary between continuous conduction and discontinuous conduction modes. The SW pin detects the zero-current condition. When this zero inductor current condition occurs, the ZX comparator turns off the rectifying MOSFET.

Adaptive Deadtime Control and Shoot-Through Protection

The driver utilizes an anti-shoot-through and adaptive dead-time control to minimize low-side body diode conduction time and maintain high efficiency. When the PWM input voltage becomes high, the low-side MOSFET gate voltage begins to fall after a propagation delay. At the same time, DRVL voltage is sensed, and high-side driving voltage starts to increase after DRVL voltage is lower than a proper threshold.

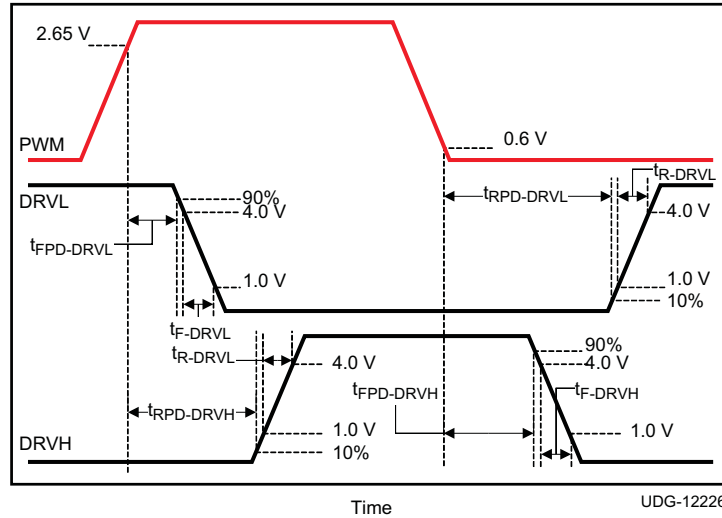

Figure 17. Rise/Fall Timing and Propagation Delay Definitions

Normal operation manages to near zero the dead-time between the low-side gate turn-off to high-side gate voltage turn-on and high-side gate turn-off to low-side gate turn-on in order to avoid simultaneous conduction of both MOSFETs as well as to reduce body diode conduction and recovery losses. This also reduces ringing on the leading edge of the SW waveform.

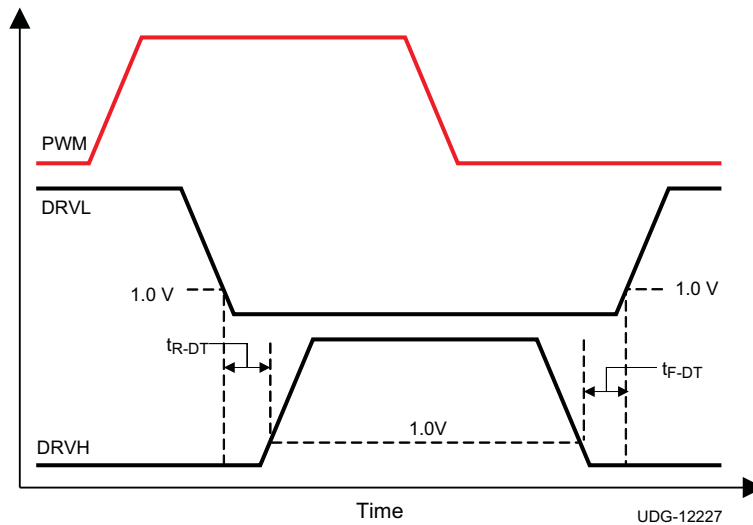

Figure 18. Dead-Time Definitions

Integrated Boost-Switch

To maintain a BST-SW voltage close to VDD (to get lower conduction losses on the high-side FET), the conventional diode between the VDD pin and the BST pin is replaced by a FET which is gated by the DRVL signal.

Layout Guidelines

To improve the switching characteristics and design efficiency, these layout rules must be considered.

- Locate the driver as close as possible to the MOSFETs.
- Locate the VDD and bootstrap capacitors as close as possible to the driver.
- Pay special attention to the GND trace. Use the thermal pad of the package as the GND by connecting it to the GND pin. The GND trace or pad from the driver goes directly to the source of the MOSFET but should not include the high current path of the main current flowing through the drain and source of the MOSFET.
- Use a similar rule for the switch-node as for the GND.
- Use wide traces for DRVH and DRVL closely following the related SW and GND traces. A width of between 80 and 100 mils is preferable where possible.
- Place the bypass capacitors as close as possible to the driver.
- Avoid PWM and enable traces going close to the SW and pad where high dV/dT voltage can induce significant noise into the relatively high impedance leads.

A poor layout can decrease the reliability of the entire system.

PACKAGING INFORMATION

Orderable Device	Status (1)	Package Type	Package Drawing	Pins	Package Qty	Eco Plan (2)	Lead/Ball Finish	MSL Peak Temp (3)	Samples (Requires Login)
TPS51604DSGR	ACTIVE	WSON	DSG	8	3000	Green (RoHS & no Sb/Br)	CU NIPDAU	Level-2-260C-1 YEAR	
TPS51604DSGT	ACTIVE	WSON	DSG	8	250	Green (RoHS & no Sb/Br)	CU NIPDAU	Level-2-260C-1 YEAR	

(1) The marketing status values are defined as follows:

ACTIVE: Product device recommended for new designs.

LIFEBUY: TI has announced that the device will be discontinued, and a lifetime-buy period is in effect.

NRND: Not recommended for new designs. Device is in production to support existing customers, but TI does not recommend using this part in a new design.

PREVIEW: Device has been announced but is not in production. Samples may or may not be available.

OBSELETE: TI has discontinued the production of the device.

(2) Eco Plan - The planned eco-friendly classification: Pb-Free (RoHS), Pb-Free (RoHS Exempt), or Green (RoHS & no Sb/Br) - please check <http://www.ti.com/productcontent> for the latest availability information and additional product content details.

TBD: The Pb-Free/Green conversion plan has not been defined.

Pb-Free (RoHS): TI's terms "Lead-Free" or "Pb-Free" mean semiconductor products that are compatible with the current RoHS requirements for all 6 substances, including the requirement that lead not exceed 0.1% by weight in homogeneous materials. Where designed to be soldered at high temperatures, TI Pb-Free products are suitable for use in specified lead-free processes.

Pb-Free (RoHS Exempt): This component has a RoHS exemption for either 1) lead-based flip-chip solder bumps used between the die and package, or 2) lead-based die adhesive used between the die and leadframe. The component is otherwise considered Pb-Free (RoHS compatible) as defined above.

Green (RoHS & no Sb/Br): TI defines "Green" to mean Pb-Free (RoHS compatible), and free of Bromine (Br) and Antimony (Sb) based flame retardants (Br or Sb do not exceed 0.1% by weight in homogeneous material)

(3) MSL, Peak Temp. -- The Moisture Sensitivity Level rating according to the JEDEC industry standard classifications, and peak solder temperature.

Important Information and Disclaimer: The information provided on this page represents TI's knowledge and belief as of the date that it is provided. TI bases its knowledge and belief on information provided by third parties, and makes no representation or warranty as to the accuracy of such information. Efforts are underway to better integrate information from third parties. TI has taken and continues to take reasonable steps to provide representative and accurate information but may not have conducted destructive testing or chemical analysis on incoming materials and chemicals. TI and TI suppliers consider certain information to be proprietary, and thus CAS numbers and other limited information may not be available for release.

In no event shall TI's liability arising out of such information exceed the total purchase price of the TI part(s) at issue in this document sold by TI to Customer on an annual basis.

TAPE AND REEL INFORMATION



QUADRANT ASSIGNMENTS FOR PIN 1 ORIENTATION IN TAPE



*All dimensions are nominal

Device	Package Type	Package Drawing	Pins	SPQ	Reel Diameter (mm)	Reel Width W1 (mm)	A0 (mm)	B0 (mm)	K0 (mm)	P1 (mm)	W (mm)	Pin1 Quadrant
TPS51604DSGR	WSON	DSG	8	3000	330.0	8.4	2.3	2.3	1.15	4.0	8.0	Q2
TPS51604DSGT	WSON	DSG	8	250	180.0	8.4	2.3	2.3	1.15	4.0	8.0	Q2

TAPE AND REEL BOX DIMENSIONS

*All dimensions are nominal

Device	Package Type	Package Drawing	Pins	SPQ	Length (mm)	Width (mm)	Height (mm)
TPS51604DSGR	WSON	DSG	8	3000	367.0	367.0	35.0
TPS51604DSGT	WSON	DSG	8	250	210.0	185.0	35.0

DSG (S-PWSON-N8)

PLASTIC SMALL OUTLINE NO-LEAD

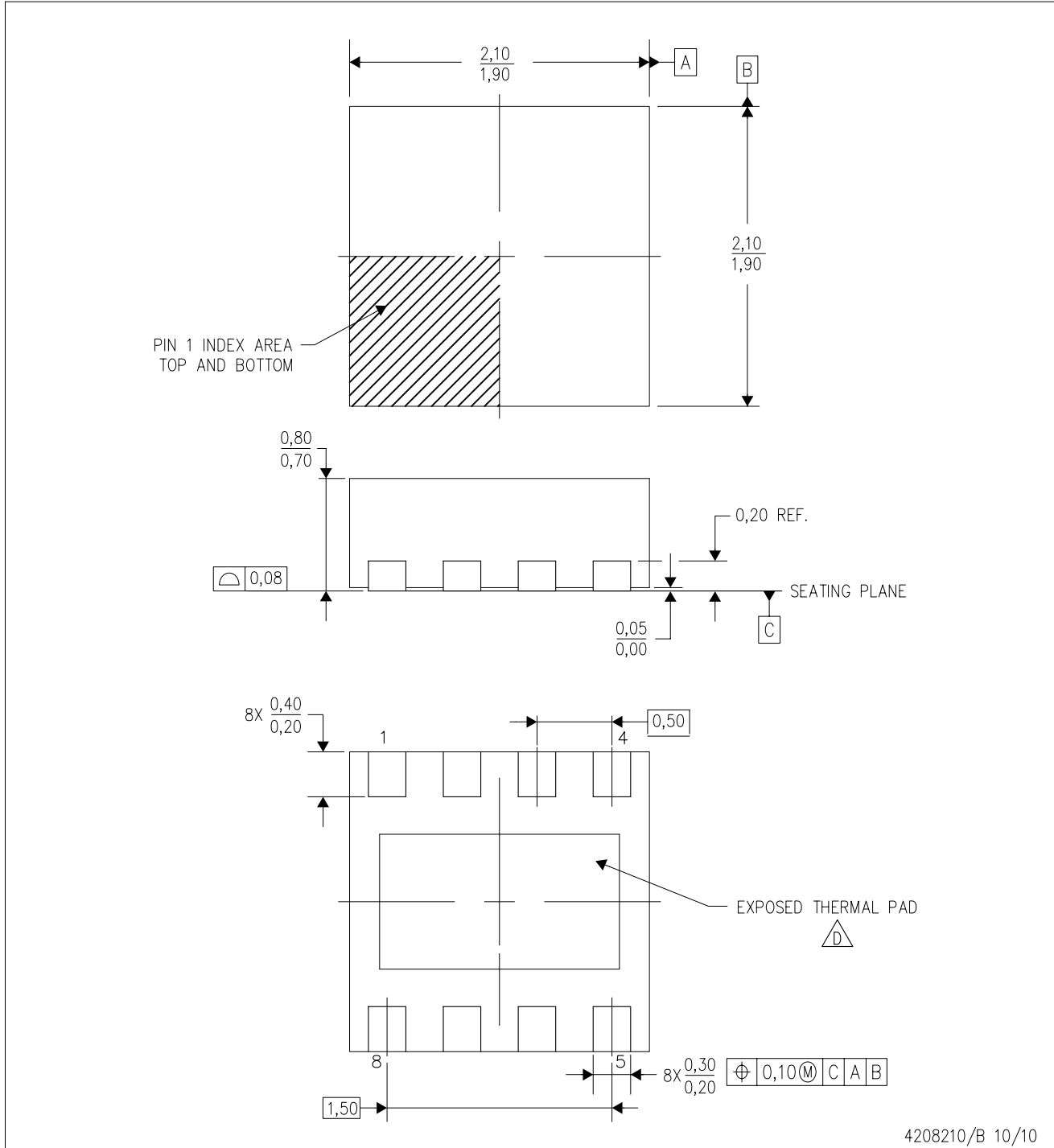

4208210/B 10/10

- NOTES:
- A. All linear dimensions are in millimeters. Dimensioning and tolerancing per ASME Y14.5M-1994.
 - B. This drawing is subject to change without notice.
 - C. Quad Flatpack, No-Leads (QFN) package configuration.
 -  The package thermal pad must be soldered to the board for thermal and mechanical performance. See the Product Data Sheet for details regarding the exposed thermal pad dimensions.
 - E. Falls within JEDEC MO-229.

THERMAL PAD MECHANICAL DATA

DSG (S-PWSON-N8)

PLASTIC SMALL OUTLINE NO-LEAD

THERMAL INFORMATION

This package incorporates an exposed thermal pad that is designed to be attached directly to an external heatsink. The thermal pad must be soldered directly to the printed circuit board (PCB). After soldering, the PCB can be used as a heatsink. In addition, through the use of thermal vias, the thermal pad can be attached directly to the appropriate copper plane shown in the electrical schematic for the device, or alternatively, can be attached to a special heatsink structure designed into the PCB. This design optimizes the heat transfer from the integrated circuit (IC).

For information on the Quad Flatpack No-Lead (QFN) package and its advantages, refer to Application Report, QFN/SON PCB Attachment, Texas Instruments Literature No. SLUA271. This document is available at www.ti.com.

The exposed thermal pad dimensions for this package are shown in the following illustration.

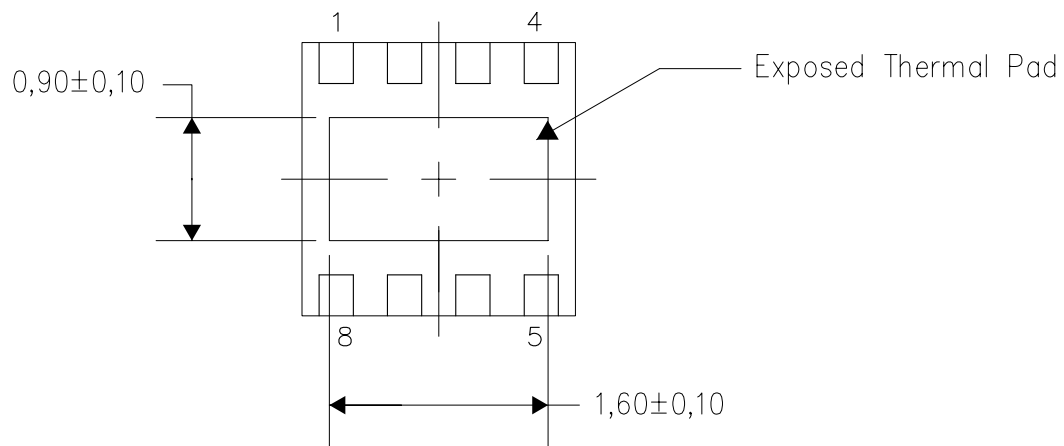

Bottom View

Exposed Thermal Pad Dimensions

4208347/E 11/10

NOTE: A. All linear dimensions are in millimeters

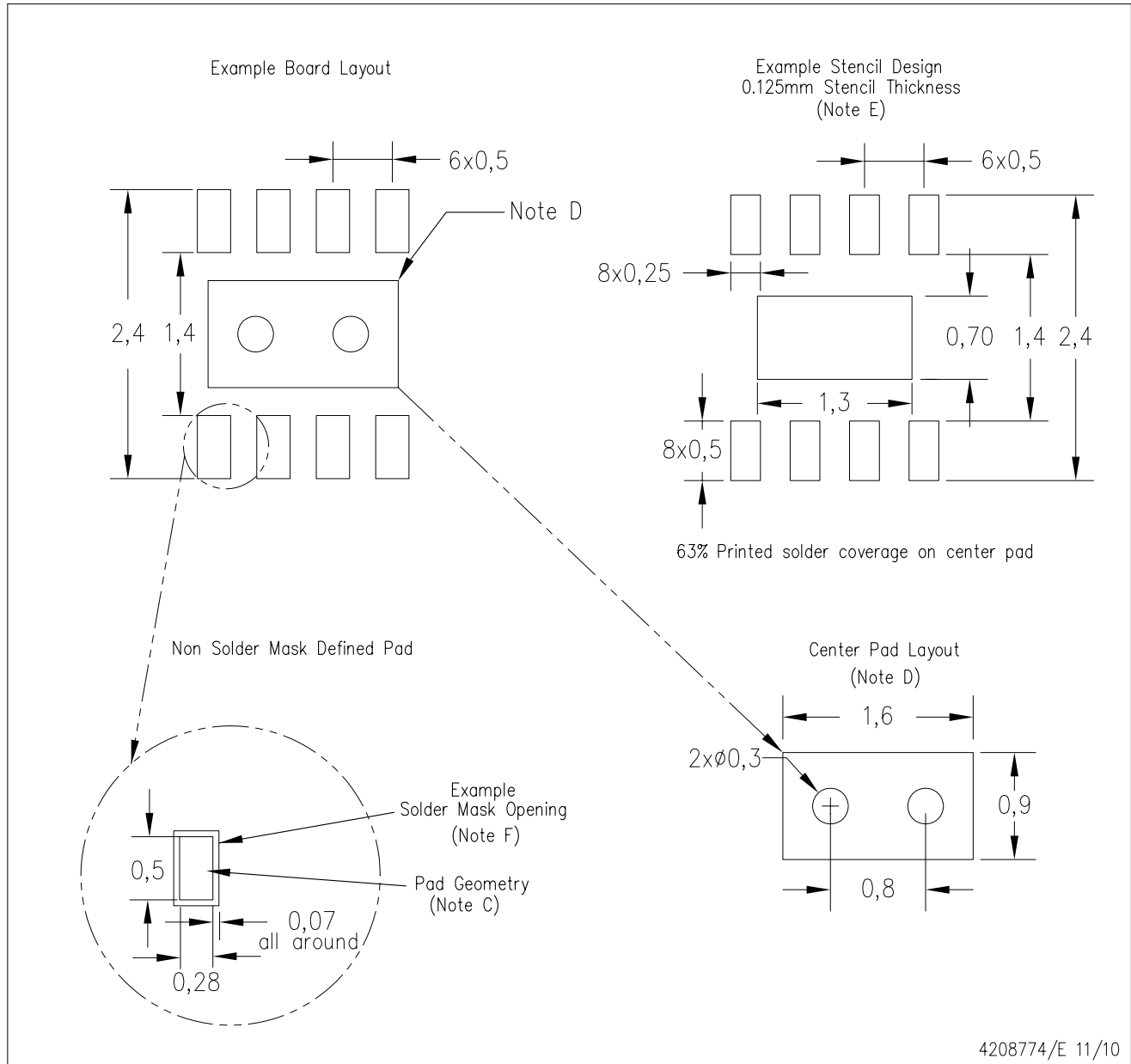

- NOTES:
- A. All linear dimensions are in millimeters.
 - B. This drawing is subject to change without notice.
 - C. Publication IPC-7351 is recommended for alternate designs.
 - D. This package is designed to be soldered to a thermal pad on the board. Refer to Application Note, QFN/SON PCB Attachment, Texas Instruments Literature No. SLUA271, and also the Product Data Sheets for specific thermal information, via requirements, and recommended board layout. These documents are available at www.ti.com <<http://www.ti.com>>.
 - E. Laser cutting apertures with trapezoidal walls and also rounding corners will offer better paste release. Customers should contact their board assembly site for stencil design recommendations. Refer to IPC 7525 for stencil design considerations.
 - F. Customers should contact their board fabrication site for solder mask tolerances.

IMPORTANT NOTICE

Texas Instruments Incorporated and its subsidiaries (TI) reserve the right to make corrections, enhancements, improvements and other changes to its semiconductor products and services per JESD46, latest issue, and to discontinue any product or service per JESD48, latest issue. Buyers should obtain the latest relevant information before placing orders and should verify that such information is current and complete. All semiconductor products (also referred to herein as "components") are sold subject to TI's terms and conditions of sale supplied at the time of order acknowledgment.

TI warrants performance of its components to the specifications applicable at the time of sale, in accordance with the warranty in TI's terms and conditions of sale of semiconductor products. Testing and other quality control techniques are used to the extent TI deems necessary to support this warranty. Except where mandated by applicable law, testing of all parameters of each component is not necessarily performed.

TI assumes no liability for applications assistance or the design of Buyers' products. Buyers are responsible for their products and applications using TI components. To minimize the risks associated with Buyers' products and applications, Buyers should provide adequate design and operating safeguards.

TI does not warrant or represent that any license, either express or implied, is granted under any patent right, copyright, mask work right, or other intellectual property right relating to any combination, machine, or process in which TI components or services are used. Information published by TI regarding third-party products or services does not constitute a license to use such products or services or a warranty or endorsement thereof. Use of such information may require a license from a third party under the patents or other intellectual property of the third party, or a license from TI under the patents or other intellectual property of TI.

Reproduction of significant portions of TI information in TI data books or data sheets is permissible only if reproduction is without alteration and is accompanied by all associated warranties, conditions, limitations, and notices. TI is not responsible or liable for such altered documentation. Information of third parties may be subject to additional restrictions.

Resale of TI components or services with statements different from or beyond the parameters stated by TI for that component or service voids all express and any implied warranties for the associated TI component or service and is an unfair and deceptive business practice. TI is not responsible or liable for any such statements.

Buyer acknowledges and agrees that it is solely responsible for compliance with all legal, regulatory and safety-related requirements concerning its products, and any use of TI components in its applications, notwithstanding any applications-related information or support that may be provided by TI. Buyer represents and agrees that it has all the necessary expertise to create and implement safeguards which anticipate dangerous consequences of failures, monitor failures and their consequences, lessen the likelihood of failures that might cause harm and take appropriate remedial actions. Buyer will fully indemnify TI and its representatives against any damages arising out of the use of any TI components in safety-critical applications.

In some cases, TI components may be promoted specifically to facilitate safety-related applications. With such components, TI's goal is to help enable customers to design and create their own end-product solutions that meet applicable functional safety standards and requirements. Nonetheless, such components are subject to these terms.

No TI components are authorized for use in FDA Class III (or similar life-critical medical equipment) unless authorized officers of the parties have executed a special agreement specifically governing such use.

Only those TI components which TI has specifically designated as military grade or "enhanced plastic" are designed and intended for use in military/aerospace applications or environments. Buyer acknowledges and agrees that any military or aerospace use of TI components which have **not** been so designated is solely at the Buyer's risk, and that Buyer is solely responsible for compliance with all legal and regulatory requirements in connection with such use.

TI has specifically designated certain components as meeting ISO/TS16949 requirements, mainly for automotive use. In any case of use of non-designated products, TI will not be responsible for any failure to meet ISO/TS16949.

Products

Audio	www.ti.com/audio
Amplifiers	amplifier.ti.com
Data Converters	dataconverter.ti.com
DLP® Products	www.dlp.com
DSP	dsp.ti.com
Clocks and Timers	www.ti.com/clocks
Interface	interface.ti.com
Logic	logic.ti.com
Power Mgmt	power.ti.com
Microcontrollers	microcontroller.ti.com
RFID	www.ti-rfid.com
OMAP Applications Processors	www.ti.com/omap
Wireless Connectivity	www.ti.com/wirelessconnectivity

Applications

Automotive and Transportation	www.ti.com/automotive
Communications and Telecom	www.ti.com/communications
Computers and Peripherals	www.ti.com/computers
Consumer Electronics	www.ti.com/consumer-apps
Energy and Lighting	www.ti.com/energy
Industrial	www.ti.com/industrial
Medical	www.ti.com/medical
Security	www.ti.com/security
Space, Avionics and Defense	www.ti.com/space-avionics-defense
Video and Imaging	www.ti.com/video

TI E2E Community

e2e.ti.com