

- 3-Pin SOT-23 Package
- Supply Current of 9 μ A (Typical)
- Precision Supply Voltage Monitor
2.5 V, 3 V, 3.3 V, 5 V
- Power-On Reset Generator With Fixed
Delay Time of 200 ms
- Pin-For-Pin Compatible With MAX 809
- Temperature Range . . . -40°C to 85°C

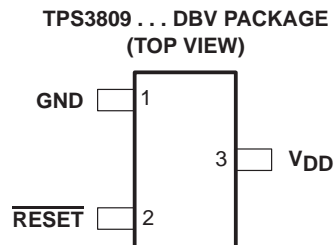

description

The TPS3809 family of supervisory circuits provides circuit initialization and timing supervision, primarily for DSPs and processor-based systems.

During power-on, $\overline{\text{RESET}}$ is asserted when the supply voltage V_{DD} becomes higher than 1.1 V. Thereafter, the supervisory circuit monitors V_{DD} and keeps $\overline{\text{RESET}}$ active as long as V_{DD} remains below the threshold voltage V_{IT} . An internal timer delays the return of the output to the inactive state (high) to ensure proper system reset. The delay time, $t_{\text{d(typ)}} = 200$ ms, starts after V_{DD} has risen above the threshold voltage V_{IT} . When the supply voltage drops below the threshold voltage V_{IT} , the output becomes active (low) again. No external components are required. All the devices of this family have a fixed sense-threshold voltage V_{IT} set by an internal voltage divider.

The product spectrum is designed for supply voltages of 2.5 V, 3 V, 3.3 V, and 5 V. The circuits are available in a 3-pin SOT-23. The TPS3809 devices are characterized for operation over a temperature range of -40°C to 85°C .

typical applications

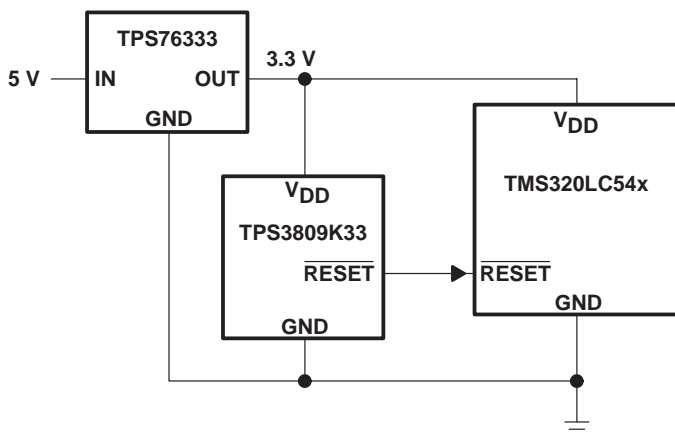

- Applications Using DSPs, Microcontrollers, or Microprocessors
- Wireless Communication Systems
- Portable/Battery-Powered Equipment
- Programmable Controls
- Intelligent Instruments
- Industrial Equipment
- Notebook/Desktop Computers
- Automotive Systems



Please be aware that an important notice concerning availability, standard warranty, and use in critical applications of Texas Instruments semiconductor products and disclaimers thereto appears at the end of this data sheet.

PRODUCTION DATA information is current as of publication date. Products conform to specifications per the terms of Texas Instruments standard warranty. Production processing does not necessarily include testing of all parameters.

 **TEXAS
INSTRUMENTS**

POST OFFICE BOX 655303 • DALLAS, TEXAS 75265

Copyright © 1999, Texas Instruments Incorporated

TPS3809J25, TPS3809L30, TPS3809K33, TPS3809I50 3-PIN SUPPLY VOLTAGE SUPERVISORS

SLVS228 – AUGUST 1999

AVAILABLE OPTIONS

T _A	DEVICE NAME		THRESHOLD VOLTAGE	MARKING
-40°C to 85°C	TPS3809J25DBVR†	TPS3809J25DBVT‡	2.25 V	PCZI
	TPS3809L30DBVR†	TPS3809L30DBVT‡	2.64 V	PDAI
	TPS3809K33DBVR†	TPS3809K33DBVT‡	2.93 V	PDBI
	TPS3809I50DBVR†	TPS3809I50DBVT‡	4.55 V	PDCI

† The DBVR passive indicates tape and reel of 3000 parts.

‡ The DBVT passive indicates tape and reel of 250 parts.

FUNCTION/TRUTH TABLE, TPS3809

V _{DD} >V _{IT}	$\overline{\text{RESET}}$
0	L
1	H

ORDERING INFORMATION

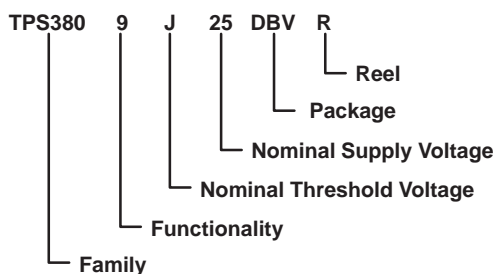

functional block diagram

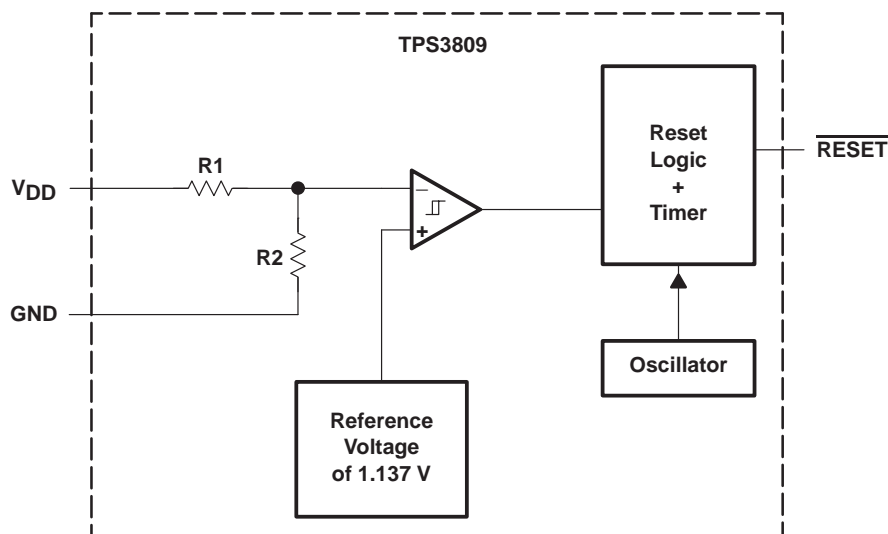

timing diagram

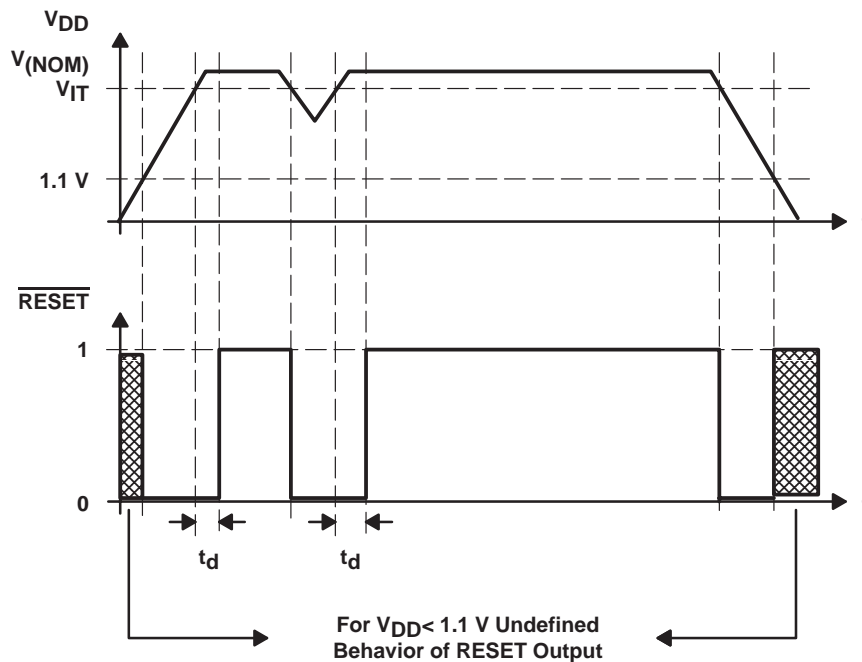

absolute maximum ratings over operating free-air temperature (unless otherwise noted)†

Supply voltage, V_{DD} (see Note 1)	7 V
All other pins (see Note 1)	-0.3 V to 7 V
Maximum low output current, I_{OL}	5 mA
Maximum high output current, I_{OH}	-5 mA
Input clamp current, I_{IK} ($V_I < 0$ or $V_I > V_{DD}$)	± 20 mA
Output clamp current, I_{OK} ($V_O < 0$ or $V_O > V_{DD}$)	± 20 mA
Continuous total power dissipation	See Dissipation Rating Table
Operating free-air temperature range, T_A	-40°C to 85°C
Storage temperature range, T_{stg}	-65°C to 150°C
Soldering temperature	260°C

† Stresses beyond those listed under “absolute maximum ratings” may cause permanent damage to the device. These are stress ratings only, and functional operation of the device at these or any other conditions beyond those indicated under “recommended operating conditions” is not implied. Exposure to absolute-maximum-rated conditions for extended periods may affect device reliability.

NOTE 1: All voltage values are with respect to GND. For reliable operation the device should not be operated at 7 V for more than $t=1000h$ continuously.

DISSIPATION RATING TABLE

PACKAGE	$T_A < 25^\circ\text{C}$ POWER RATING	DERATING FACTOR ABOVE $T_A = 25^\circ\text{C}$	$T_A = 70^\circ\text{C}$ POWER RATING	$T_A = 85^\circ\text{C}$ POWER RATING
DBV	437 mW	3.5 mW/°C	280 mW	227 mW

recommended operating conditions at specified temperature range

	MIN	MAX	UNIT
Supply voltage, V_{DD}	2	6	V
Operating free-air temperature range, T_A	-40	85	°C

TPS3809J25, TPS3809L30, TPS3809K33, TPS3809I50

3-PIN SUPPLY VOLTAGE SUPERVISORS

SLVS228 – AUGUST 1999

electrical characteristics over recommended operating free-air temperature range (unless otherwise noted)

PARAMETER		TEST CONDITIONS	MIN	TYP	MAX	UNIT	
V _{OH}	High-level output voltage	V _{DD} = 2.5 V to 6 V, I _{OH} = -500 μA	V _{DD} - 0.2			V	
		V _{DD} = 3.3 V, I _{OH} = -2 mA	V _{DD} - 0.4				
		V _{DD} = 6 V, I _{OH} = -4 mA	V _{DD} - 0.4				
V _{OL}	Low-level output voltage	V _{DD} = 2 V to 6 V, I _{OL} = 500 μA	0.2			V	
		V _{DD} = 3.3 V, I _{OL} = 2 mA	0.4				
		V _{DD} = 6 V, I _{OL} = 4 mA	0.4				
Power-up reset voltage (see Note 2)		V _{DD} ≥ 1.1 V, I _{OL} = 50 μA	0.2			V	
V _{IT-}	Negative-going input threshold voltage (see Note 3)	T _A = 40°C to 85°C	TPS3809J25	2.20	2.25	2.30	V
			TPS3809L30	2.58	2.64	2.70	
			TPS3809K33	2.87	2.93	2.99	
			TPS3809I50	4.45	4.55	4.65	
V _{hys}	Hysteresis		TPS3809J25	30		mV	
			TPS3809L30	35			
			TPS3809K33	40			
			TPS3809I50	60			
I _{DD}	Supply current	V _{DD} = 2 V, Output unconnected	9		12	μA	
		V _{DD} = 6 V, Output unconnected	20		25		
C _i	Input capacitance	V _I = 0 V to V _{DD}	5			pF	

NOTES: 2. The lowest supply voltage at which $\overline{\text{RESET}}$ becomes active. $t_r, V_{DD} \geq 15 \mu\text{s/V}$.
 3. To ensure best stability of the threshold voltage, a bypass capacitor (0.1 μF ceramic) should be placed near the supply terminals.

timing requirements at R_L = 1 MΩ, C_L = 50 pF, T_A = 25°C

PARAMETER		TEST CONDITIONS	MIN	TYP	MAX	UNIT
t _w	Pulse width	at V _{DD} V _{DD} = V _{IT-} + 0.2 V, V _{DD} = V _{IT-} - 0.2 V	3			μs

switching characteristics at R_L = 1 MΩ, C_L = 50 pF, T_A = 25°C

PARAMETER		TEST CONDITIONS	MIN	TYP	MAX	UNIT
t _d	Delay time	V _{DD} ≥ V _{IT-} + 0.2 V, See timing diagram	120	200	280	ms
t _{PHL}	Propagation (delay) time, high-to-low-level output	V _{DD} to $\overline{\text{RESET}}$ delay V _{IL} = V _{IT-} - 0.2 V, V _{IH} = V _{IT-} + 0.2 V	1			μs



TYPICAL CHARACTERISTICS

LOW-LEVEL OUTPUT VOLTAGE
vs
LOW-LEVEL OUTPUT CURRENT

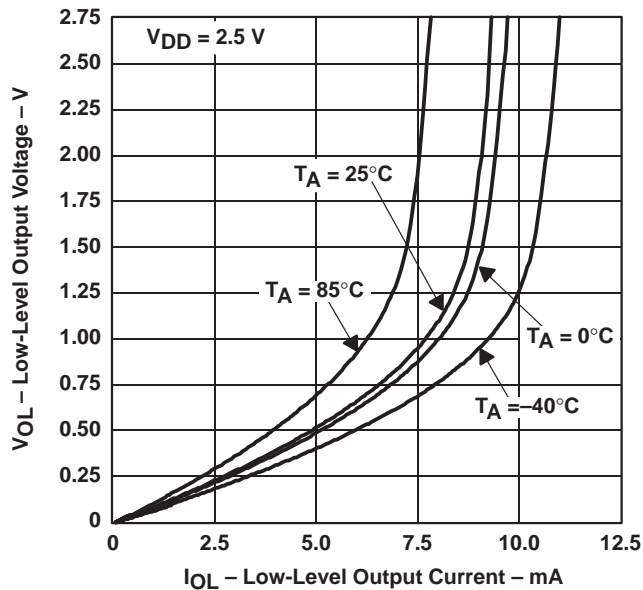

Figure 1

SUPPLY CURRENT
vs
SUPPLY VOLTAGE

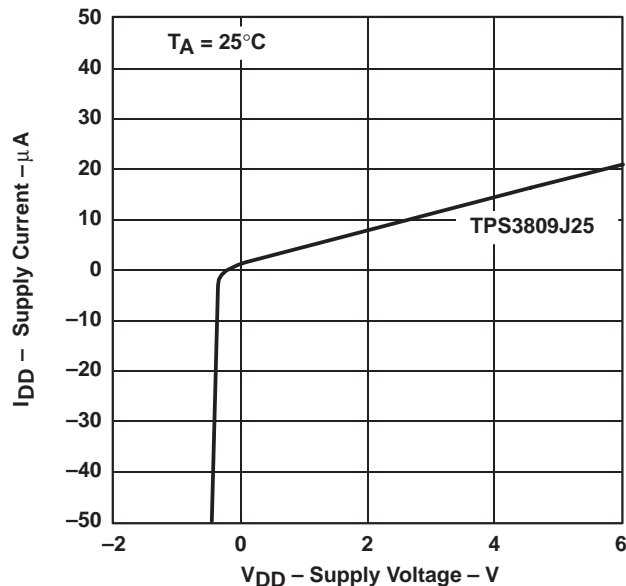

Figure 2

HIGH-LEVEL OUTPUT VOLTAGE
vs
HIGH-LEVEL OUTPUT CURRENT

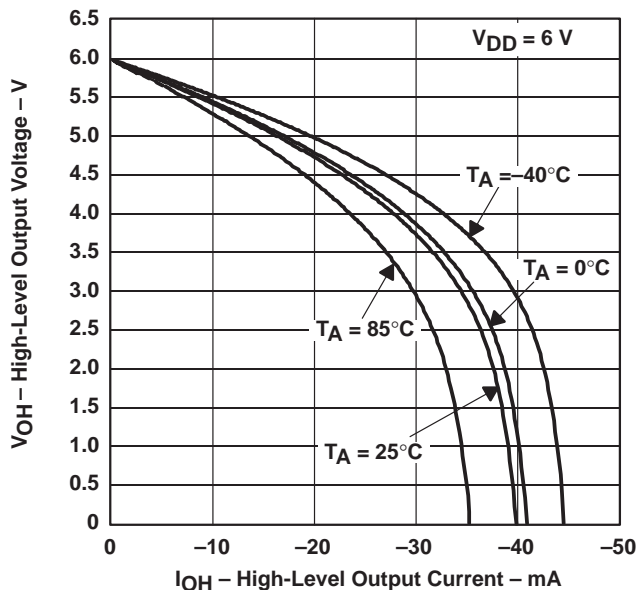

Figure 3

HIGH-LEVEL OUTPUT VOLTAGE
vs
HIGH-LEVEL OUTPUT CURRENT

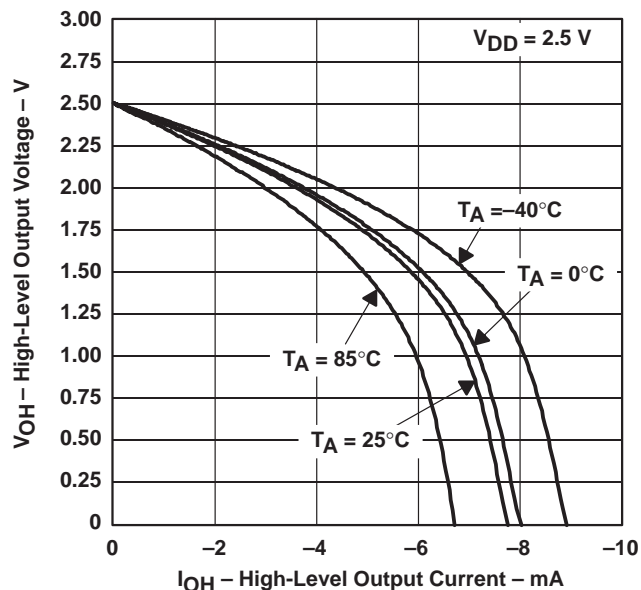

Figure 4

TYPICAL CHARACTERISTICS

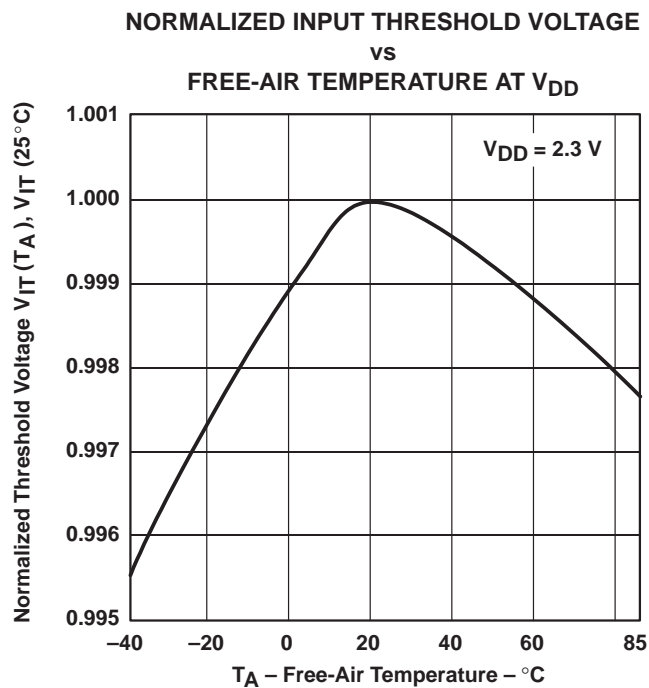

Figure 5

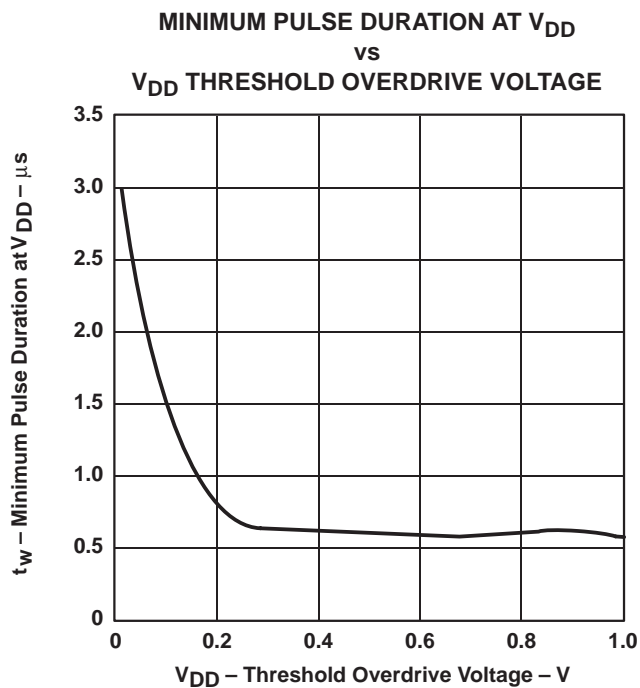
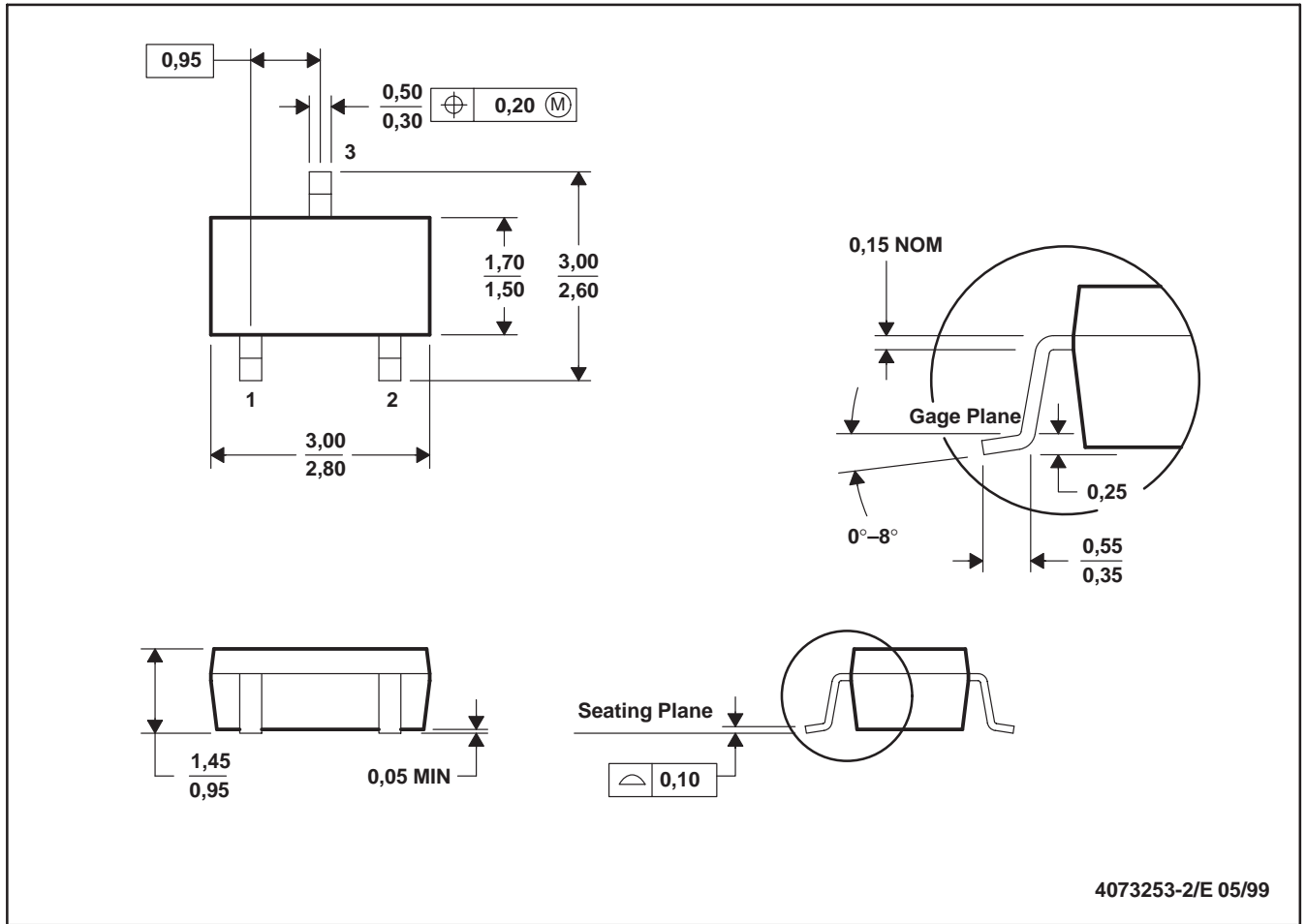

Figure 6

MECHANICAL DATA

DBV (R-PDSO-G3)

PLASTIC SMALL-OUTLINE



- NOTES: A. All linear dimensions are in millimeters.
B. This drawing is subject to change without notice.
C. Body dimensions do not include mold flash or protrusion.

IMPORTANT NOTICE

Texas Instruments and its subsidiaries (TI) reserve the right to make changes to their products or to discontinue any product or service without notice, and advise customers to obtain the latest version of relevant information to verify, before placing orders, that information being relied on is current and complete. All products are sold subject to the terms and conditions of sale supplied at the time of order acknowledgement, including those pertaining to warranty, patent infringement, and limitation of liability.

TI warrants performance of its semiconductor products to the specifications applicable at the time of sale in accordance with TI's standard warranty. Testing and other quality control techniques are utilized to the extent TI deems necessary to support this warranty. Specific testing of all parameters of each device is not necessarily performed, except those mandated by government requirements.

CERTAIN APPLICATIONS USING SEMICONDUCTOR PRODUCTS MAY INVOLVE POTENTIAL RISKS OF DEATH, PERSONAL INJURY, OR SEVERE PROPERTY OR ENVIRONMENTAL DAMAGE ("CRITICAL APPLICATIONS"). TI SEMICONDUCTOR PRODUCTS ARE NOT DESIGNED, AUTHORIZED, OR WARRANTED TO BE SUITABLE FOR USE IN LIFE-SUPPORT DEVICES OR SYSTEMS OR OTHER CRITICAL APPLICATIONS. INCLUSION OF TI PRODUCTS IN SUCH APPLICATIONS IS UNDERSTOOD TO BE FULLY AT THE CUSTOMER'S RISK.

In order to minimize risks associated with the customer's applications, adequate design and operating safeguards must be provided by the customer to minimize inherent or procedural hazards.

TI assumes no liability for applications assistance or customer product design. TI does not warrant or represent that any license, either express or implied, is granted under any patent right, copyright, mask work right, or other intellectual property right of TI covering or relating to any combination, machine, or process in which such semiconductor products or services might be or are used. TI's publication of information regarding any third party's products or services does not constitute TI's approval, warranty or endorsement thereof.