

## TPS3808Gxx-Q1 Low-Quiescent-Current Programmable-Delay Supervisory Circuit

### 1 Features

- Qualified for Automotive Applications
- Power-On Reset Generator With Adjustable Delay Time: 1.25 ms to 10 s
- Very Low Quiescent Current: 2.4  $\mu$ A Typical
- High Threshold Accuracy: 0.5% Typical
- Fixed Threshold Voltages for Standard Voltage Rails From 1.2 V to 5 V and Adjustable Voltage Down to 0.4 V Are Available
- Manual Reset ( $\overline{\text{MR}}$ ) Input
- Open-Drain  $\overline{\text{RESET}}$  Output
- Temperature Range:  $-40^{\circ}\text{C}$  to  $125^{\circ}\text{C}$
- Small SOT-23 Package

### 2 Applications

- DSP or Microcontroller Applications
- FPGA and ASIC Applications
- Automotive Vision
- Automotive Radar

### 3 Description

The TPS3808Gxx-Q1 microprocessor supervisory circuits monitor system voltages from 0.4 V to 5 V, asserting an open-drain  $\overline{\text{RESET}}$  signal when the SENSE voltage drops below a preset threshold or when the manual reset ( $\overline{\text{MR}}$ ) pin drops to a logic low. The  $\overline{\text{RESET}}$  output remains low for the user-adjustable delay time after the SENSE voltage and  $\overline{\text{MR}}$  return above their thresholds.

The TPS3808Gxx-Q1 device uses a precision reference to achieve 0.5% threshold accuracy for  $V_{\text{IT}} \leq 3.3$  V. The reset delay time can be set to 20 ms by disconnecting the  $C_{\text{T}}$  pin, 300 ms by connecting the  $C_{\text{T}}$  pin to  $V_{\text{DD}}$  using a resistor, or can be user-adjusted from 1.25 ms to 10 s by connecting the  $C_{\text{T}}$  pin to an external capacitor. The TPS3808Gxx-Q1 has a very low typical quiescent current of 2.4  $\mu$ A, so it is well suited for battery-powered applications. The device is available in a small SOT-23 package and is fully specified over a temperature range of  $-40^{\circ}\text{C}$  to  $125^{\circ}\text{C}$  ( $T_{\text{J}}$ ).

For more information about TI's voltage supervisor portfolio, visit the [Supervisor and Reset IC Overview Page](#).

#### Device Information<sup>(1)</sup>

PART NUMBER	PACKAGE	BODY SIZE (NOM)
TPS3808Gxx-Q1	SOT-23 (6)	2.90 mm x 1.60 mm
	SON (6)	2.00 mm x 2.00 mm

(1) For all available packages, see the orderable addendum at the end of the data sheet.

#### Typical Application Schematic

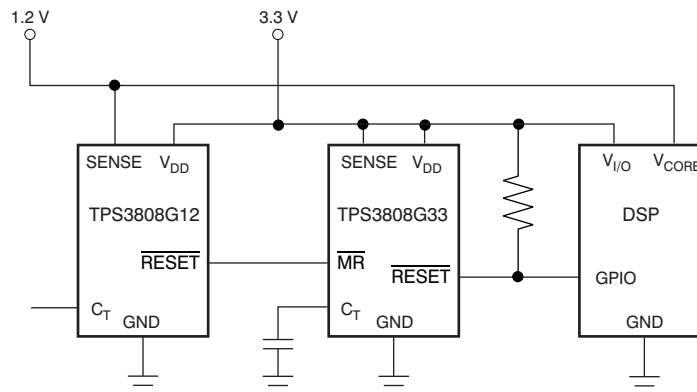

## Table of Contents

<b>1 Features</b> .....	<b>1</b>	8.3 Feature Description .....	<b>9</b>
<b>2 Applications</b> .....	<b>1</b>	8.4 Device Functional Modes .....	<b>11</b>
<b>3 Description</b> .....	<b>1</b>	<b>9 Applications and Implementation</b> .....	<b>12</b>
<b>4 Revision History</b> .....	<b>2</b>	9.1 Application Information .....	<b>12</b>
<b>5 Device Comparison Table</b> .....	<b>3</b>	9.2 Typical Application .....	<b>12</b>
<b>6 Pin Configuration and Functions</b> .....	<b>3</b>	<b>10 Power Supply Recommendations</b> .....	<b>14</b>
<b>7 Specifications</b> .....	<b>4</b>	<b>11 Layout</b> .....	<b>14</b>
7.1 Absolute Maximum Ratings .....	<b>4</b>	11.1 Layout Guidelines .....	<b>14</b>
7.2 ESD Ratings .....	<b>4</b>	11.2 Layout Example .....	<b>14</b>
7.3 Recommended Operating Conditions .....	<b>4</b>	<b>12 Device and Documentation Support</b> .....	<b>15</b>
7.4 Thermal Information .....	<b>5</b>	12.1 Related Links .....	<b>15</b>
7.5 Electrical Characteristics .....	<b>5</b>	12.2 Community Resources .....	<b>15</b>
7.6 Timing Requirements .....	<b>6</b>	12.3 Trademarks .....	<b>15</b>
7.7 Typical Characteristics .....	<b>7</b>	12.4 Electrostatic Discharge Caution .....	<b>15</b>
<b>8 Detailed Description</b> .....	<b>8</b>	12.5 Glossary .....	<b>15</b>
8.1 Overview .....	<b>8</b>	<b>13 Mechanical, Packaging, and Orderable Information</b> .....	<b>15</b>
8.2 Functional Block Diagrams .....	<b>8</b>		

## 4 Revision History

NOTE: Page numbers for previous revisions may differ from page numbers in the current version.

Changes from Revision H (June 2012) to Revision I	Page
<ul style="list-style-type: none"> <li>Added <i>ESD Ratings</i> table, <i>Feature Description</i> section, <i>Device Functional Modes</i>, <i>Application and Implementation</i> section, <i>Power Supply Recommendations</i> section, <i>Layout</i> section, <i>Device and Documentation Support</i> section, and <i>Mechanical, Packaging, and Orderable Information</i> section .....</li> </ul>	<b>1</b>

Changes from Revision G (November, 2010) to Revision H	Page
<ul style="list-style-type: none"> <li>Changed <math>I_{SENSE}</math> from <math>\mu A</math> to <math>nA</math> .....</li> </ul>	<b>5</b>

## 5 Device Comparison Table

ORDERABLE PART NUMBER	NOMINAL SUPPLY VOLTAGE	THRESHOLD VOLTAGE ( $V_{IT}$ )
TPS3808G01QDRVRQ1	Adjustable	0.405 V
TPS3808G01QDBVRQ1		
TPS3808G12QDBVRQ1	1.2 V	1.12 V
TPS3808G125QDBVRQ1	1.25 V	1.16 V
TPS3808G15QDBVRQ1	1.5 V	1.4 V
TPS3808G18QDBVRQ1	1.8 V	1.67 V
TPS3808G30QDBVRQ1	3 V	2.79 V
TPS3808G33QDBVRQ1	3.3 V	3.07 V
TPS3808G50QDBVRQ1	5 V	4.65 V

## 6 Pin Configuration and Functions



### Pin Functions

PIN		I/O	DESCRIPTION
NAME	NO.		
$C_T$	4	I	Reset period programming. Connecting this pin to $V_{DD}$ through a 40-k $\Omega$ to 200-k $\Omega$ resistor or leaving it open results in fixed delay times (see <a href="#">Electrical Characteristics</a> ). Connecting this pin to a ground referenced capacitor $\geq 100$ pF gives a user-programmable delay time.
GND	2	—	Ground
$\overline{MR}$	3	I	Manual reset. Driving this pin low asserts $\overline{RESET}$ . $\overline{MR}$ is internally tied to $V_{DD}$ by a 90-k $\Omega$ pullup resistor.
$\overline{RESET}$	1	O	Reset. This is an open-drain output that is driven to a low impedance state when $\overline{RESET}$ is asserted (either the SENSE input is lower than the threshold voltage ( $V_{IT}$ ) or the $\overline{MR}$ pin is set to a logic low). $\overline{RESET}$ remains low (asserted) for the reset period after both SENSE is above $V_{IT}$ and $\overline{MR}$ is set to a logic high. A pullup resistor from 10 k $\Omega$ to 1 M $\Omega$ should be used on this pin, and allows the reset pin to attain voltages higher than $V_{DD}$ .
SENSE	5	I	Voltage sense. This pin is connected to the voltage to be monitored. If the voltage at this terminal drops below the threshold voltage ( $V_{IT}$ ), $\overline{RESET}$ is asserted.
$V_{DD}$	6	I	Supply voltage. It is good analog design practice to place a 0.1- $\mu$ F ceramic capacitor close to this pin.

## 7 Specifications

### 7.1 Absolute Maximum Ratings

over operating junction temperature range (unless otherwise noted)<sup>(1)</sup>

		MIN	MAX	UNIT
V <sub>DD</sub>	Input voltage	-0.3	7	V
V <sub>CT</sub>	C <sub>T</sub> voltage	-0.3	(V <sub>DD</sub> + 0.3)	V
V <sub>MR</sub> , V <sub>RESET</sub> , V <sub>SENSE</sub>	$\overline{\text{MR}}$ , $\overline{\text{RESET}}$ , SENSE voltage	-0.3	7	V
I <sub>RESET</sub>	$\overline{\text{RESET}}$ pin current		5	mA
T <sub>J</sub>	Operating junction temperature <sup>(2)</sup>	-40	150	°C
T <sub>stg</sub>	Storage temperature	-65	150	°C

- (1) Stresses beyond those listed under *Absolute Maximum Ratings* may cause permanent damage to the device. These are stress ratings only, and functional operation of the device at these or any other conditions beyond those indicated under the *Electric Characteristics* is not implied. Exposure to absolute-maximum-rated conditions for extended periods may affect device reliability.
- (2) Due to the low dissipated power in this device, it is assumed that T<sub>J</sub> = T<sub>A</sub>.

### 7.2 ESD Ratings

		VALUE	UNIT
<b>TPS3808G125QDBVRQ1 IN SOT-23 PACKAGE</b>			
V <sub>(ESD)</sub>	Electrostatic discharge	Human body model (HBM), per AEC Q100-002 <sup>(1)</sup>	±2000
		Charged device model (CDM), per AEC Q100-011	±1000
		Machine Model (MM)	±50
<b>TPS3808GXX-Q1 IN SOT-23 PACKAGE</b>			
V <sub>(ESD)</sub>	Electrostatic discharge	Human body model (HBM), per AEC Q100-002 <sup>(1)</sup>	±2000
		Charged device model (CDM), per AEC Q100-011	±500
<b>TPS3808G01QDRVRQ1 IN SON PACKAGE</b>			
V <sub>(ESD)</sub>	Electrostatic discharge	Human body model (HBM), per AEC Q100-002 <sup>(1)</sup>	±2000
		Charged device model (CDM), per AEC Q100-011	±500
		Machine Model (MM)	±50

- (1) AEC Q100-002 indicates HBM stressing is done in accordance with the ANSI/ESDA/JEDEC JS-001 specification.

### 7.3 Recommended Operating Conditions

over operating free-air temperature range (unless otherwise noted)

	MIN	NOM	MAX	UNIT
V <sub>DD</sub> Input supply range	1.8		6.5	V
V <sub>SENSE</sub> SENSE pin voltage	0		V <sub>DD</sub>	V
$\overline{\text{MR}}$ Manual reset pin voltage	0		V <sub>DD</sub>	V

## 7.4 Thermal Information

THERMAL METRIC <sup>(1)</sup>		TPS3808Gxx-Q1		UNIT
		DBV (SOT-23)	DRV (SON)	
		6 PINS	6 PINS	
R <sub>θJA</sub>	Junction-to-ambient thermal resistance	180.9	178.1	°C/W
R <sub>θJC(top)</sub>	Junction-to-case (top) thermal resistance	117.8	95.6	°C/W
R <sub>θJB</sub>	Junction-to-board thermal resistance	27.8	135	°C/W
ψ <sub>JT</sub>	Junction-to-top characterization parameter	18.9	6.3	°C/W
ψ <sub>JB</sub>	Junction-to-board characterization parameter	27.3	136.6	°C/W
R <sub>θJC(bot)</sub>	Junction-to-case (bottom) thermal resistance	N/A	7.3	°C/W

(1) For more information about traditional and new thermal metrics, see the *Semiconductor and IC Package Thermal Metrics* application report, [SPRA953](#).

## 7.5 Electrical Characteristics

1.8 V ≤ V<sub>DD</sub> ≤ 6.5 V, R<sub>LRESET</sub> = 100 kΩ, C<sub>LRESET</sub> = 50 pF, over operating temperature range (T<sub>J</sub> = –40°C to 125°C) (unless otherwise noted), typical values at T<sub>J</sub> = 25°C

PARAMETER		TEST CONDITIONS		MIN	TYP	MAX	UNIT
V <sub>DD</sub>	Input supply range			1.8		6.5	V
I <sub>DD</sub>	Supply current (into V <sub>DD</sub> pin)	V <sub>DD</sub> = 3.3 V, $\overline{\text{RESET}}$ not asserted, $\overline{\text{MR}}$ , $\overline{\text{RESET}}$ , C <sub>T</sub> open			2.4	5	μA
		V <sub>DD</sub> = 6.5 V, $\overline{\text{RESET}}$ not asserted, $\overline{\text{MR}}$ , $\overline{\text{RESET}}$ , C <sub>T</sub> open			2.7	6	
V <sub>OL</sub>	Low-level output voltage	1.3 V ≤ V <sub>DD</sub> < 1.8 V, I <sub>OL</sub> = 0.4 mA				0.3	V
		1.8 V ≤ V <sub>DD</sub> ≤ 6.5 V, I <sub>OL</sub> = 1 mA				0.4	
	Power-up reset voltage <sup>(1)</sup>	V <sub>OL</sub> (max) = 0.2 V, I <sub><math>\overline{\text{RESET}}</math></sub> = 15 μA				0.8	V
V <sub>IT</sub>	Negative-going input threshold accuracy	TPS3808G01-Q1		–2%	±1%	2%	
		V <sub>IT</sub> ≤ 3.3 V		–1.5%	±0.5%	1.5%	
		3.3 V < V <sub>IT</sub> ≤ 5 V		–2%	±1%	2%	
		–40°C < T <sub>J</sub> < 85°C		–1.25%	±0.5%	1.25%	
		3.3 V < V <sub>IT</sub> ≤ 5 V		–1.5%	±0.5%	1.5%	
V <sub>HYS</sub>	Hysteresis on V <sub>IT</sub> pin	TPS3808G01-Q1			1.5	3	%V <sub>IT</sub>
		–40°C < T <sub>J</sub> < 85°C			1	2	
					1	2.5	
R <sub><math>\overline{\text{MR}}</math></sub>	$\overline{\text{MR}}$ internal pullup resistance	V <sub>SENSE</sub> = V <sub>IT</sub>		70	90		kΩ
I <sub>SENSE</sub>	Input current at SENSE pin	TPS3808G01-Q1		–25		25	nA
		V <sub>SENSE</sub> = 6.5 V			1.7		μA
I <sub>OH</sub>	$\overline{\text{RESET}}$ leakage current	V <sub><math>\overline{\text{RESET}}</math></sub> = 6.5 V, $\overline{\text{RESET}}$ not asserted				300	nA
C <sub>IN</sub>	Input capacitance, any pin	C <sub>T</sub> pin	V <sub>IN</sub> = 0 V to V <sub>DD</sub>		5		pF
		Other pins	V <sub>IN</sub> = 0 V to 6.5 V		5		
V <sub>IL</sub>	$\overline{\text{MR}}$ logic low input			0		0.3 V <sub>DD</sub>	V
V <sub>IH</sub>	$\overline{\text{MR}}$ logic high input			0.7 V <sub>DD</sub>		V <sub>DD</sub>	V

(1) Power-up reset voltage is the lowest supply voltage (V<sub>DD</sub>) at which  $\overline{\text{RESET}}$  becomes active (t<sub>rise(VDD)</sub> ≥ 15 μs/V).

## 7.6 Timing Requirements

				MIN	TYP	MAX	UNIT
$t_d$	$\overline{\text{RESET}}$ delay time	$C_T = \text{Open}$	See Figure 1	12	20	28	ms
		$C_T = V_{DD}$		180	300	420	
		$C_T = 100 \text{ pF}$		0.75	1.25	1.75	
		$C_T = 180 \text{ nF}$		0.7	1.2	1.7	
$t_{pHL}$	Propagation delay	$\overline{\text{MR}}$ to $\overline{\text{RESET}}$	$V_{IH} = 0.7 V_{DD}, V_{IL} = 0.3 V_{DD}$	150		ns	
	High-level to low-level $\overline{\text{RESET}}$ delay	$\overline{\text{SENSE}}$ to $\overline{\text{RESET}}$	$V_{IH} = 1.05 V_{IT}, V_{IL} = 0.95 V_{IT}$	20		$\mu\text{s}$	
$t_w$	Maximum transient duration	$\overline{\text{SENSE}}$	$V_{IH} = 1.05 V_{IT}, V_{IL} = 0.95 V_{IT}$	20		$\mu\text{s}$	
		$\overline{\text{MR}}$	$V_{IH} = 0.7 V_{DD}, V_{IL} = 0.3 V_{DD}$	0.001			

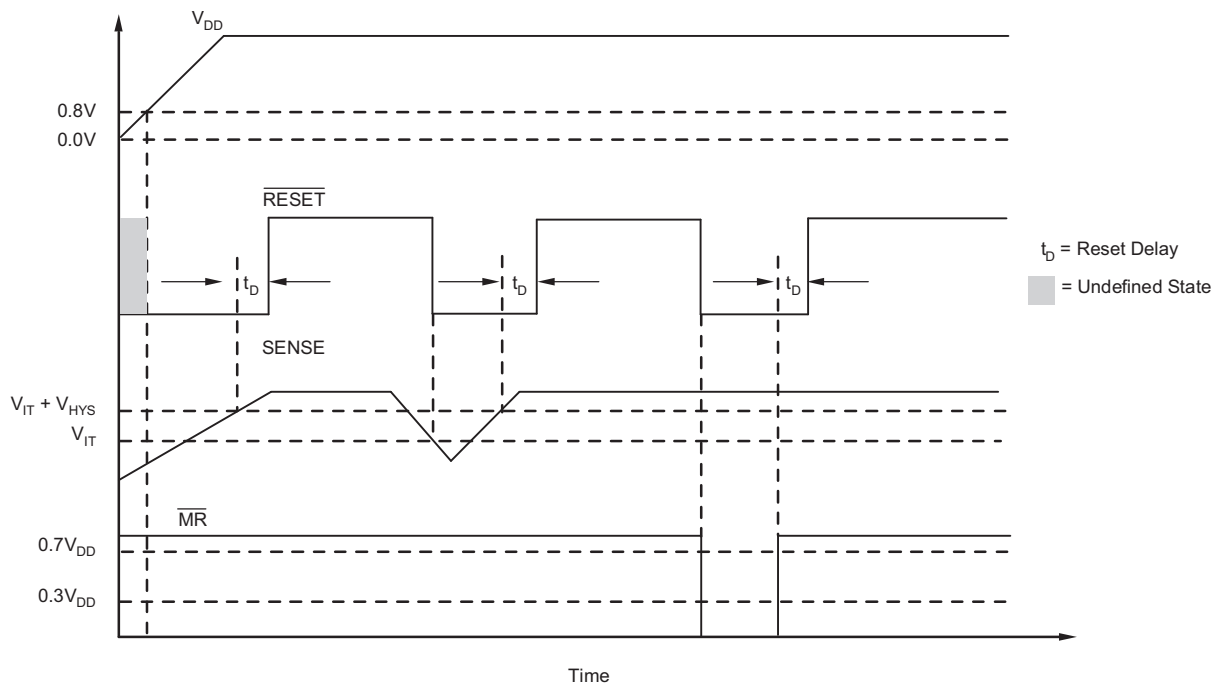

Figure 1.  $\overline{\text{MR}}$  and  $\overline{\text{SENSE}}$  Reset Timing Diagram

## 7.7 Typical Characteristics

At  $T_J = 25^\circ\text{C}$ ,  $V_{DD} = 3.3\text{ V}$ ,  $R_{L\text{RESET}} = 100\text{ k}\Omega$ , and  $C_{L\text{RESET}} = 50\text{ pF}$  (unless otherwise noted)

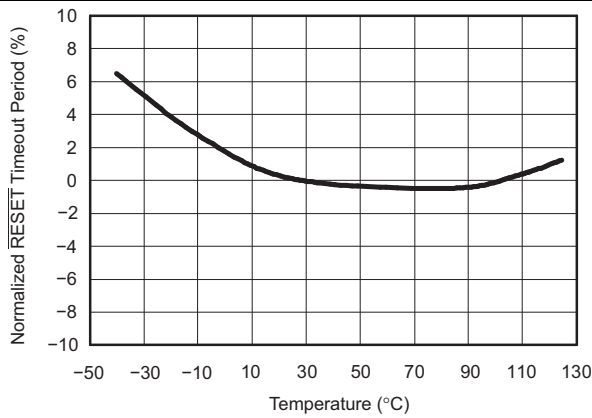

Figure 2. Normalized  $\overline{\text{RESET}}$  Time-out Period vs Temperature ( $C_T = \text{Open}$ ,  $C_T = V_{DD}$ ,  $C_T = \text{Any}$ )

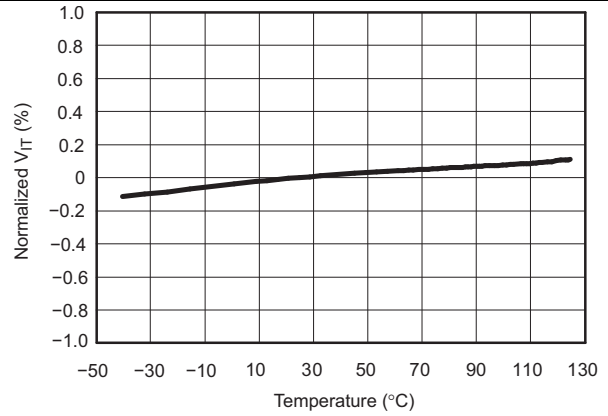

Figure 3. Normalized Sense Threshold Voltage ( $V_{IT}$ ) vs Temperature

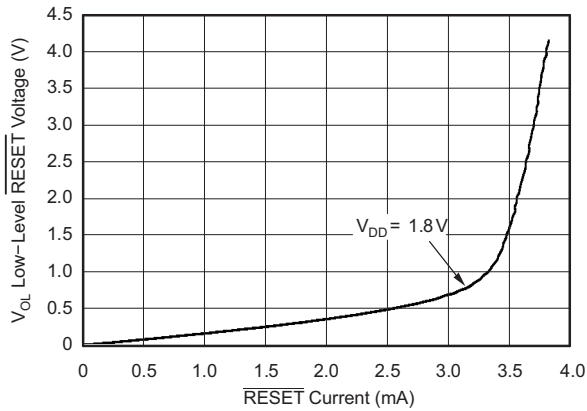

Figure 4. Low-Level  $\overline{\text{RESET}}$  Voltage vs  $\overline{\text{RESET}}$  Current

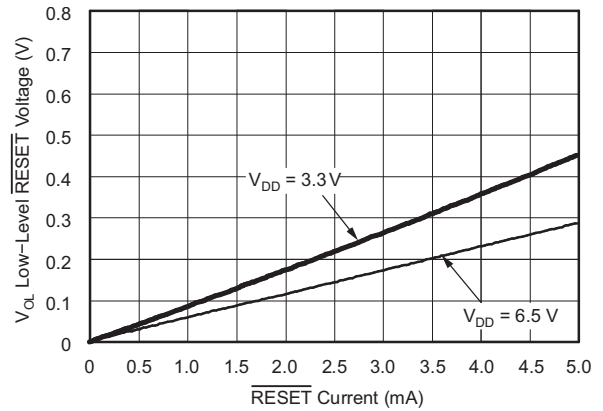

Figure 5. Low-Level  $\overline{\text{RESET}}$  Voltage vs  $\overline{\text{RESET}}$  Current

## 8 Detailed Description

### 8.1 Overview

The TPS3808Gxx-Q1 devices are low-current supervisory circuits used to monitor system voltages ranging from 0.4 V to 5 V. The devices assert an active low, open-drain  $\overline{\text{RESET}}$  signal when the  $\overline{\text{SENSE}}$  voltage drops below a preset threshold or when the manual reset ( $\overline{\text{MR}}$ ) pin is asserted to a logic low. The  $\overline{\text{RESET}}$  output remains low for the user-adjustable delay time after the  $\overline{\text{SENSE}}$  voltage and  $\overline{\text{MR}}$  return above their thresholds. The devices are also designed to be immune to short negative transients on the  $\overline{\text{SENSE}}$  pin. The reset delay time can be configured by using the  $C_T$  pin. The delay can be configured to 20 ms by leaving the  $C_T$  pin floating, it can be configured to 300 ms by connecting the  $C_T$  pin to  $V_{DD}$  using a resistor, or can be configured from 1.25 ms to 10 s by connecting the  $C_T$  pin to an external capacitor.

### 8.2 Functional Block Diagrams

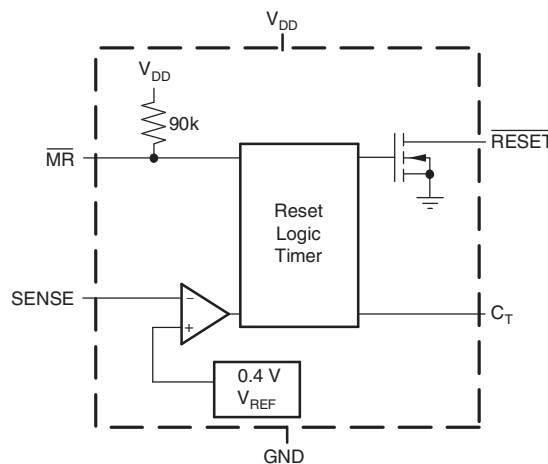

Figure 6. Adjustable-Voltage Version

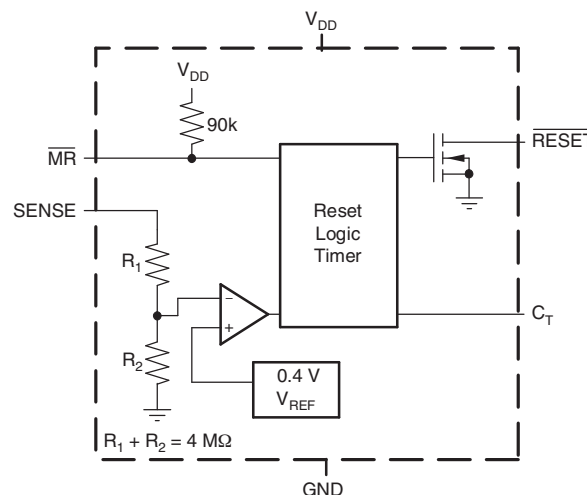

Figure 7. Fixed-Voltage Version



### 8.3 Feature Description

#### 8.3.1 Immunity to SENSE Pin Voltage Transients

The TPS3808Gxx-Q1 is relatively immune to short negative transients on the SENSE pin. Sensitivity to transients is dependent on threshold overdrive, as shown in the *Maximum Transient Duration at Sense vs Sense Threshold Overdrive Voltage* graph (Figure 9). This graph shows the duration that the transient is below  $V_{IT}$  compared to the magnitude of the voltage drop below  $V_{IT}$ , or overdrive voltage. The overdrive voltage is expressed as a percentage of the  $V_{IT}$  threshold value. Any combination of transient duration and overdrive voltage that lies above the curve results in  $\overline{\text{RESET}}$  being asserted low. Any transient that lies below the curve is ignored by the device.

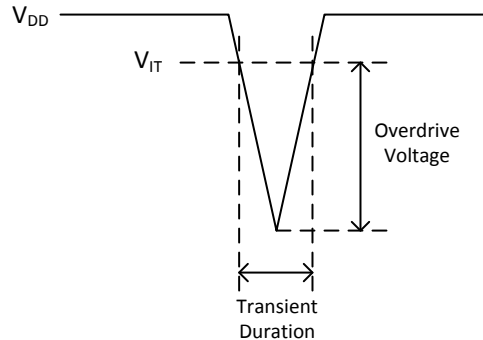

Figure 8. Threshold Overdrive Voltage

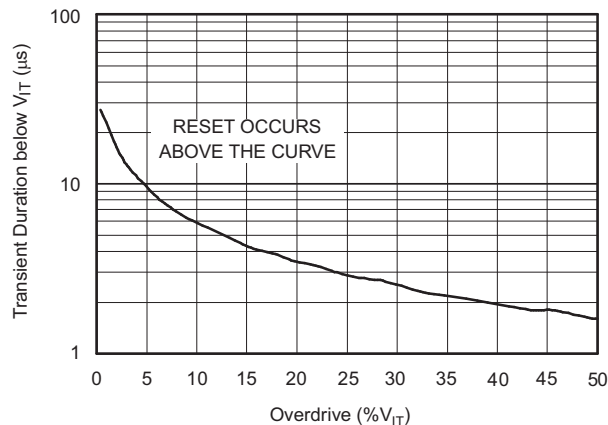

Figure 9. Maximum Transient Duration at Sense vs Sense Threshold Overdrive Voltage

#### 8.3.2 SENSE Input

The SENSE input provides a terminal at which any system voltage can be monitored. If the voltage on this pin drops below  $V_{IT}$ ,  $\overline{\text{RESET}}$  is asserted low. The comparator has a built-in hysteresis to ensure smooth  $\overline{\text{RESET}}$  assertions and deassertions. It is good analog design practice to put a 1-nF to 10-nF bypass capacitor on the SENSE input to reduce sensitivity to transients and layout parasitics.

## Feature Description (continued)

The TPS3808G01-Q1 can be used to monitor any voltage rail down to 0.405 V using the circuit shown in Figure 10.

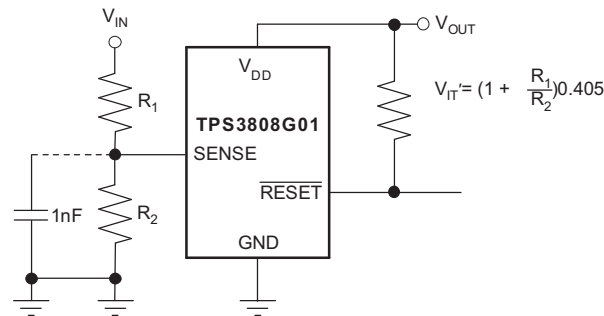

Figure 10. Using the TPS3808G01-Q1 to Monitor a User-Defined Threshold Voltage

### 8.3.3 Manual Reset ( $\overline{MR}$ ) Input

The manual reset ( $\overline{MR}$ ) input allows a processor or other logic circuits to initiate a reset. A logic low ( $0.3 V_{DD}$ ) on  $\overline{MR}$  causes  $\overline{RESET}$  to assert low. After  $\overline{MR}$  returns to a logic high and SENSE is above its reset threshold,  $\overline{RESET}$  is deasserted high after the user-defined reset delay expires.  $\overline{MR}$  is internally tied to  $V_{DD}$  using a 90-k $\Omega$  resistor, so this pin can be left unconnected if  $\overline{MR}$  is not used.

See Figure 11 for how  $\overline{MR}$  can be used to monitor multiple system voltages. If the logic signal driving  $\overline{MR}$  does not go fully to  $V_{DD}$ , there will be some additional current draw into  $V_{DD}$  as a result of the internal pullup resistor on  $\overline{MR}$ . To minimize current draw, a logic-level FET can be used as shown in Figure 12.

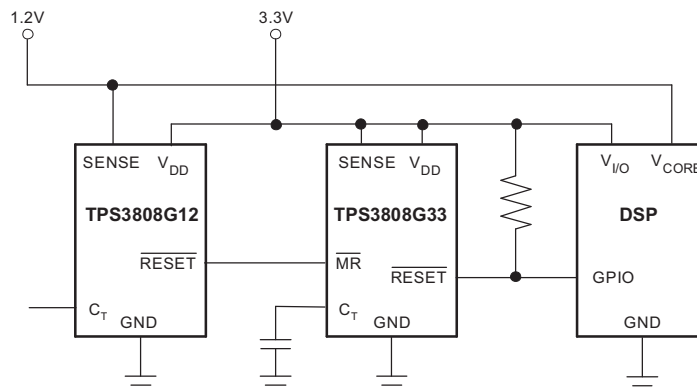

Figure 11. Using  $\overline{MR}$  to Monitor Multiple System Voltages

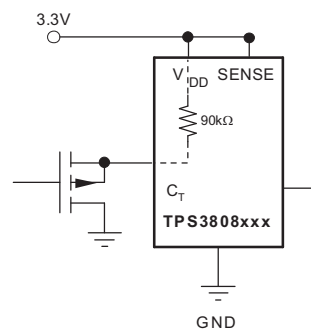

Figure 12. Using an External MOSFET to Minimize  $I_{DD}$  When  $\overline{MR}$  Signal Does Not Go to  $V_{DD}$

## Feature Description (continued)

### 8.3.4 Selecting the Reset Delay Time

The TPS3808Gxx-Q1 device has three options for setting the  $\overline{\text{RESET}}$  delay time as shown in Figure 13. Figure 13 (a) shows the configuration for a fixed 300-ms typical delay time by tying  $C_T$  to  $V_{DD}$ ; a resistor from 40 k $\Omega$  to 200 k $\Omega$  must be used. Supply current is not affected by the choice of resistor. Figure 13 (b) shows a fixed 20-ms delay time by leaving the  $C_T$  pin open. Figure 13 (c) shows a ground referenced capacitor connected to  $C_T$  for a user-defined program time from 1.25 ms to 10 s.

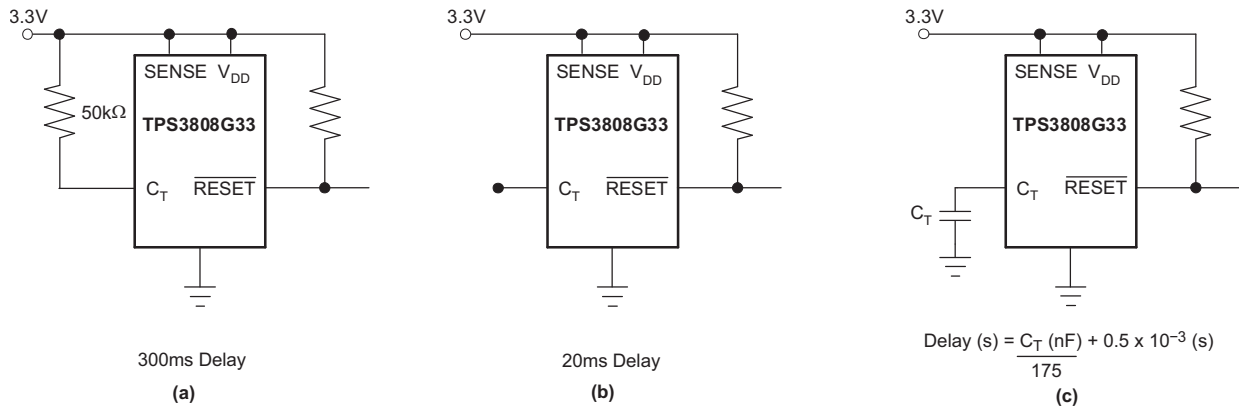

Figure 13. Configuration Used to Set the  $\overline{\text{RESET}}$  Delay Time

The capacitor  $C_T$  should be  $\geq 100$  pF nominal value for the TPS3808Gxx-Q1 to recognize the capacitor is present. Use Equation 1 to calculate the capacitor value for a given delay time.

$$C_T \text{ (nF)} = \left[ t_D \text{ (s)} - 0.5 \times 10^{-3} \text{ (s)} \right] \times 175 \quad (1)$$

The reset delay time is determined by the time it takes an on-chip precision 220-nA current source to charge the external capacitor to 1.23 V. When  $\overline{\text{RESET}}$  asserts low, the capacitor is discharged. When the  $\overline{\text{RESET}}$  conditions are cleared, the internal current source is enabled and begins to charge the external capacitor. When the voltage on this capacitor reaches 1.23 V,  $\overline{\text{RESET}}$  deasserts. A low-leakage type capacitor such as a ceramic should be used and that stray capacitance around this pin may cause errors in the reset delay time.

## 8.4 Device Functional Modes

Whenever  $\overline{\text{MR}}$  pin is set to a logic high and the SENSE input pin is higher than  $V_{IT}$ , the open-drain  $\overline{\text{RESET}}$  signal is deasserted high. If  $\overline{\text{MR}}$  pin is set to a logic low or the SENSE input pin falls lower than  $V_{IT}$ , then  $\overline{\text{RESET}}$  is asserted low. Table 1 is a truth table that describes these operating modes.

Table 1. Truth Table

$\overline{\text{MR}}$	SENSE > $V_{IT}$	$\overline{\text{RESET}}$
L	0	L
L	1	L
H	0	L
H	1	H

## 9 Applications and Implementation

### NOTE

Information in the following applications sections is not part of the TI component specification, and TI does not warrant its accuracy or completeness. TI's customers are responsible for determining suitability of components for their purposes. Customers should validate and test their design implementation to confirm system functionality.

### 9.1 Application Information

The TPS3808Gxx-Q1 microprocessor supervisory product family is designed to assert a  $\overline{\text{RESET}}$  signal when either the SENSE pin voltage drops below  $V_{IT}$  or the manual reset ( $\overline{\text{MR}}$ ) is driven low. The  $\overline{\text{RESET}}$  output remains asserted for a user-adjustable time after both the manual reset ( $\overline{\text{MR}}$ ) and SENSE voltages return above the respective thresholds. A broad range of voltage threshold and reset delay time adjustments are available, allowing these devices to be used in a variety of applications. Reset threshold voltages can be factory-set from 0.82 V to 3.3 V or from 4.4 V to 5 V, while the TPS3808G01-Q1 can be set to any voltage above 0.405 V using an external resistor divider. Two preset delay times are also user-selectable: connecting the  $C_T$  pin to  $V_{DD}$  results in a 300-ms reset delay, while leaving the  $C_T$  pin open yields a 20-ms reset delay. Additionally, connecting a capacitor between  $C_T$  and GND allows the designer to select any reset delay period from 1.25 ms to 10 s.

### 9.2 Typical Application

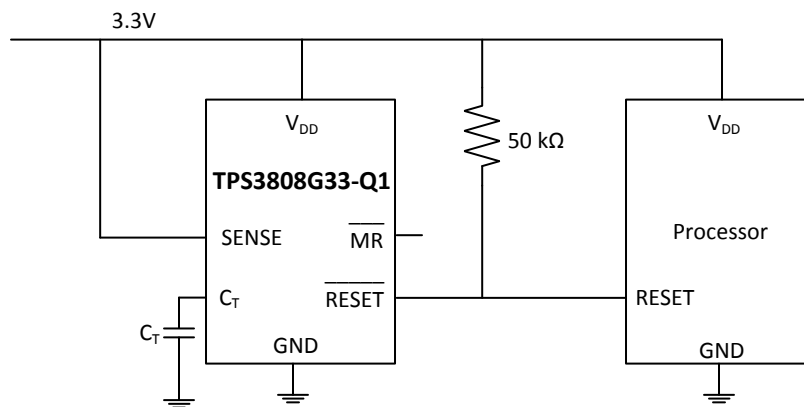

Figure 14. TPS3808G33-Q1 Typical Application

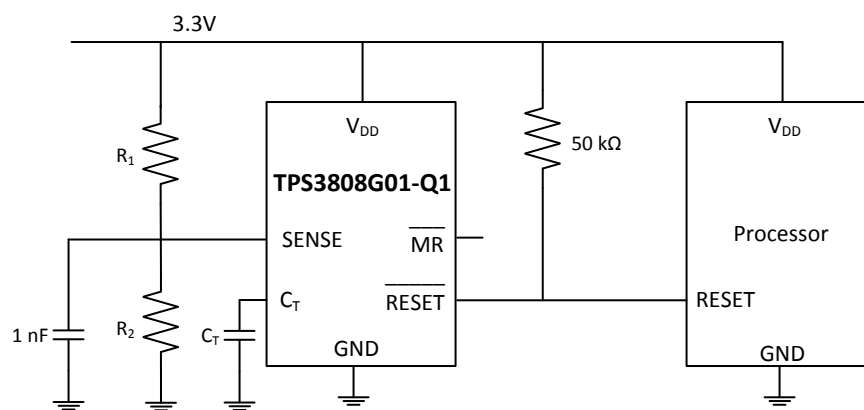

Figure 15. TPS3808G01-Q1 Typical Application

## Typical Application (continued)

### 9.2.1 Design Requirements

The TPS3808Gxx-Q1 device must monitor a 3.3-V input voltage, and drive an active-low reset to the processor when the input voltage drops below the recommended operating voltage of the processor.

### 9.2.2 Detailed Design Procedure

To monitor the 3.3-V input voltage, TPS3808G33-Q1 is used and the 3.3-V supply is connected directly to the SENSE pin. The open-drain  $\overline{\text{RESET}}$  output is connected to VCC through a 50-k $\Omega$  resistor. To select the output delay on the  $\overline{\text{RESET}}$  pin, connect the  $C_T$  pin to  $V_{DD}$ , left floating, or connect through a capacitor to GND. For more details on selecting this delay, see [Selecting the Reset Delay Time](#).

When using TPS3808G01-Q1, select R1 and R2 resistor values to select the threshold voltage based on the following equation:  $V_{IT} = (1 + R1 / R2) \times 0.405$ .

### 9.2.3 Application Curves

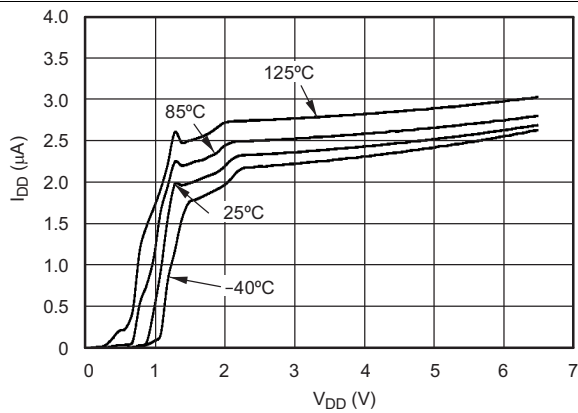

Figure 16. Supply Current vs Supply Voltage

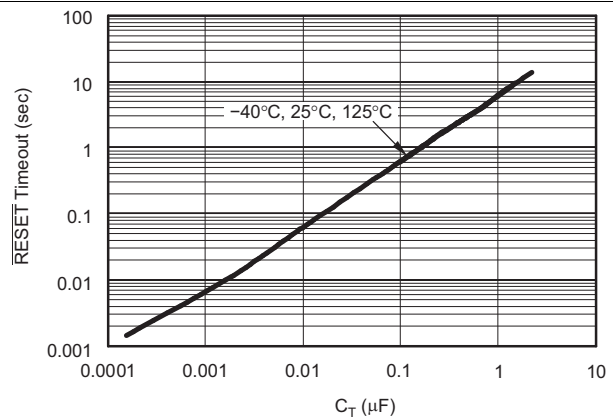

Figure 17.  $\overline{\text{RESET}}$  Time-out Period vs  $C_T$

## 10 Power Supply Recommendations

The TPS3808Gxx-Q1 devices are designed to operate from an input supply from 1.8 V to 6.5 V. TI recommends placing a 0.1- $\mu$ F capacitor near the  $V_{DD}$  pin.

## 11 Layout

### 11.1 Layout Guidelines

TI recommends placing the 0.1- $\mu$ F decoupling capacitor close to the  $V_{DD}$  pin. The  $V_{DD}$  trace should be able to carry 6- $\mu$ A without a significant drop in voltage.

### 11.2 Layout Example

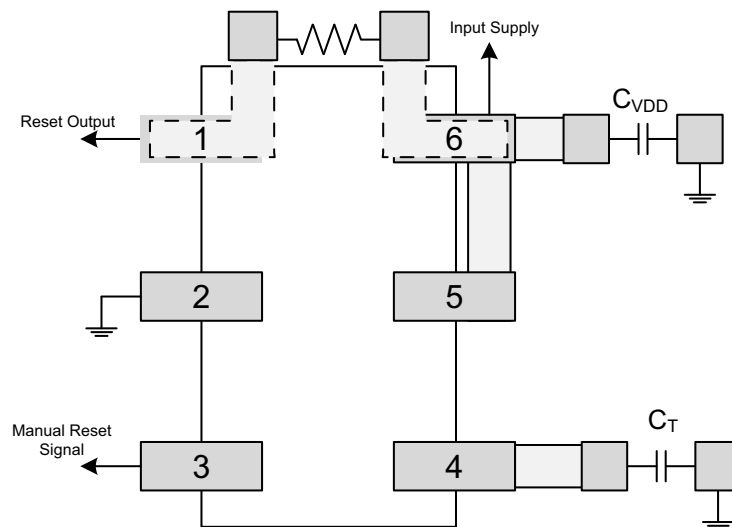

Figure 18. Recommended Layout

## 12 Device and Documentation Support

### 12.1 Related Links

The table below lists quick access links. Categories include technical documents, support and community resources, tools and software, and quick access to sample or buy.

**Table 2. Related Links**

PARTS	PRODUCT FOLDER	SAMPLE & BUY	TECHNICAL DOCUMENTS	TOOLS & SOFTWARE	SUPPORT & COMMUNITY
TPS3808G01-Q1	<a href="#">Click here</a>	<a href="#">Click here</a>	<a href="#">Click here</a>	<a href="#">Click here</a>	<a href="#">Click here</a>
TPS3808G12-Q1	<a href="#">Click here</a>	<a href="#">Click here</a>	<a href="#">Click here</a>	<a href="#">Click here</a>	<a href="#">Click here</a>
TPS3808G125-Q1	<a href="#">Click here</a>	<a href="#">Click here</a>	<a href="#">Click here</a>	<a href="#">Click here</a>	<a href="#">Click here</a>
TPS3808G15-Q1	<a href="#">Click here</a>	<a href="#">Click here</a>	<a href="#">Click here</a>	<a href="#">Click here</a>	<a href="#">Click here</a>
TPS3808G18-Q1	<a href="#">Click here</a>	<a href="#">Click here</a>	<a href="#">Click here</a>	<a href="#">Click here</a>	<a href="#">Click here</a>
TPS3808G30-Q1	<a href="#">Click here</a>	<a href="#">Click here</a>	<a href="#">Click here</a>	<a href="#">Click here</a>	<a href="#">Click here</a>
TPS3808G33-Q1	<a href="#">Click here</a>	<a href="#">Click here</a>	<a href="#">Click here</a>	<a href="#">Click here</a>	<a href="#">Click here</a>
TPS3808G50-Q1	<a href="#">Click here</a>	<a href="#">Click here</a>	<a href="#">Click here</a>	<a href="#">Click here</a>	<a href="#">Click here</a>

### 12.2 Community Resources

The following links connect to TI community resources. Linked contents are provided "AS IS" by the respective contributors. They do not constitute TI specifications and do not necessarily reflect TI's views; see TI's [Terms of Use](#).

**TI E2E™ Online Community** *TI's Engineer-to-Engineer (E2E) Community*. Created to foster collaboration among engineers. At [e2e.ti.com](http://e2e.ti.com), you can ask questions, share knowledge, explore ideas and help solve problems with fellow engineers.

**Design Support** *TI's Design Support* Quickly find helpful E2E forums along with design support tools and contact information for technical support.

### 12.3 Trademarks

E2E is a trademark of Texas Instruments.  
All other trademarks are the property of their respective owners.

### 12.4 Electrostatic Discharge Caution



These devices have limited built-in ESD protection. The leads should be shorted together or the device placed in conductive foam during storage or handling to prevent electrostatic damage to the MOS gates.

### 12.5 Glossary

**SLYZ022** — *TI Glossary*.

This glossary lists and explains terms, acronyms, and definitions.

## 13 Mechanical, Packaging, and Orderable Information

The following pages include mechanical, packaging, and orderable information. This information is the most current data available for the designated devices. This data is subject to change without notice and revision of this document. For browser-based versions of this data sheet, refer to the left-hand navigation.

**PACKAGING INFORMATION**

Orderable Device	Status (1)	Package Type	Package Drawing	Pins	Package Qty	Eco Plan (2)	Lead/Ball Finish (6)	MSL Peak Temp (3)	Op Temp (°C)	Device Marking (4/5)	Samples
TPS3808G01QDBVRQ1	ACTIVE	SOT-23	DBV	6	3000	Green (RoHS & no Sb/Br)	CU NIPDAU	Level-1-260C-UNLIM	-40 to 125	BAZ	<a href="#">Samples</a>
TPS3808G01QDRVRQ1	ACTIVE	WSON	DRV	6	3000	Green (RoHS & no Sb/Br)	CU NIPDAU	Level-2-260C-1 YEAR	-40 to 125	PSJQ	<a href="#">Samples</a>
TPS3808G125QDBVRQ1	ACTIVE	SOT-23	DBV	6	3000	Green (RoHS & no Sb/Br)	CU NIPDAU	Level-1-260C-UNLIM	-40 to 125	QWZ	<a href="#">Samples</a>
TPS3808G12QDBVRQ1	ACTIVE	SOT-23	DBV	6	3000	Green (RoHS & no Sb/Br)	CU NIPDAU	Level-1-260C-UNLIM	-40 to 125	CEM	<a href="#">Samples</a>
TPS3808G15QDBVRQ1	ACTIVE	SOT-23	DBV	6	3000	Green (RoHS & no Sb/Br)	CU NIPDAU	Level-1-260C-UNLIM	-40 to 125	OFV	<a href="#">Samples</a>
TPS3808G18QDBVRQ1	ACTIVE	SOT-23	DBV	6	3000	Green (RoHS & no Sb/Br)	CU NIPDAU	Level-1-260C-UNLIM	-40 to 125	OBZ	<a href="#">Samples</a>
TPS3808G30QDBVRQ1	ACTIVE	SOT-23	DBV	6	3000	Green (RoHS & no Sb/Br)	CU NIPDAU	Level-1-260C-UNLIM	-40 to 125	AVP	<a href="#">Samples</a>
TPS3808G33QDBVRQ1	ACTIVE	SOT-23	DBV	6	3000	Green (RoHS & no Sb/Br)	CU NIPDAU	Level-1-260C-UNLIM	-40 to 125	AVQ	<a href="#">Samples</a>
TPS3808G50QDBVRQ1	ACTIVE	SOT-23	DBV	6	3000	Green (RoHS & no Sb/Br)	CU NIPDAU	Level-1-260C-UNLIM	-40 to 125	CEL	<a href="#">Samples</a>

(1) The marketing status values are defined as follows:

**ACTIVE:** Product device recommended for new designs.

**LIFEBUY:** TI has announced that the device will be discontinued, and a lifetime-buy period is in effect.

**NRND:** Not recommended for new designs. Device is in production to support existing customers, but TI does not recommend using this part in a new design.

**PREVIEW:** Device has been announced but is not in production. Samples may or may not be available.

**OBSOLETE:** TI has discontinued the production of the device.

(2) Eco Plan - The planned eco-friendly classification: Pb-Free (RoHS), Pb-Free (RoHS Exempt), or Green (RoHS & no Sb/Br) - please check <http://www.ti.com/productcontent> for the latest availability information and additional product content details.

**TBD:** The Pb-Free/Green conversion plan has not been defined.

**Pb-Free (RoHS):** TI's terms "Lead-Free" or "Pb-Free" mean semiconductor products that are compatible with the current RoHS requirements for all 6 substances, including the requirement that lead not exceed 0.1% by weight in homogeneous materials. Where designed to be soldered at high temperatures, TI Pb-Free products are suitable for use in specified lead-free processes.

**Pb-Free (RoHS Exempt):** This component has a RoHS exemption for either 1) lead-based flip-chip solder bumps used between the die and package, or 2) lead-based die adhesive used between the die and leadframe. The component is otherwise considered Pb-Free (RoHS compatible) as defined above.

**Green (RoHS & no Sb/Br):** TI defines "Green" to mean Pb-Free (RoHS compatible), and free of Bromine (Br) and Antimony (Sb) based flame retardants (Br or Sb do not exceed 0.1% by weight in homogeneous material)



- 
- (3) MSL, Peak Temp. - The Moisture Sensitivity Level rating according to the JEDEC industry standard classifications, and peak solder temperature.
- (4) There may be additional marking, which relates to the logo, the lot trace code information, or the environmental category on the device.
- (5) Multiple Device Markings will be inside parentheses. Only one Device Marking contained in parentheses and separated by a "-" will appear on a device. If a line is indented then it is a continuation of the previous line and the two combined represent the entire Device Marking for that device.
- (6) Lead/Ball Finish - Orderable Devices may have multiple material finish options. Finish options are separated by a vertical ruled line. Lead/Ball Finish values may wrap to two lines if the finish value exceeds the maximum column width.

**Important Information and Disclaimer:**The information provided on this page represents TI's knowledge and belief as of the date that it is provided. TI bases its knowledge and belief on information provided by third parties, and makes no representation or warranty as to the accuracy of such information. Efforts are underway to better integrate information from third parties. TI has taken and continues to take reasonable steps to provide representative and accurate information but may not have conducted destructive testing or chemical analysis on incoming materials and chemicals. TI and TI suppliers consider certain information to be proprietary, and thus CAS numbers and other limited information may not be available for release.

In no event shall TI's liability arising out of such information exceed the total purchase price of the TI part(s) at issue in this document sold by TI to Customer on an annual basis.

**OTHER QUALIFIED VERSIONS OF TPS3808G01-Q1, TPS3808G12-Q1, TPS3808G125-Q1, TPS3808G15-Q1, TPS3808G18-Q1, TPS3808G30-Q1, TPS3808G33-Q1, TPS3808G50-Q1 :**

- Catalog: [TPS3808G01](#), [TPS3808G12](#), [TPS3808G125](#), [TPS3808G15](#), [TPS3808G18](#), [TPS3808G30](#), [TPS3808G33](#), [TPS3808G50](#)

NOTE: Qualified Version Definitions:

- Catalog - TI's standard catalog product

**TAPE AND REEL INFORMATION**

**QUADRANT ASSIGNMENTS FOR PIN 1 ORIENTATION IN TAPE**

\*All dimensions are nominal

Device	Package Type	Package Drawing	Pins	SPQ	Reel Diameter (mm)	Reel Width W1 (mm)	A0 (mm)	B0 (mm)	K0 (mm)	P1 (mm)	W (mm)	Pin1 Quadrant
TPS3808G01QDBVRQ1	SOT-23	DBV	6	3000	179.0	8.4	3.2	3.2	1.4	4.0	8.0	Q3
TPS3808G01QDRVRQ1	WSON	DRV	6	3000	180.0	8.4	2.3	2.3	1.15	4.0	8.0	Q2
TPS3808G125QDBVRQ1	SOT-23	DBV	6	3000	179.0	8.4	3.2	3.2	1.4	4.0	8.0	Q3
TPS3808G12QDBVRQ1	SOT-23	DBV	6	3000	179.0	8.4	3.2	3.2	1.4	4.0	8.0	Q3
TPS3808G15QDBVRQ1	SOT-23	DBV	6	3000	179.0	8.4	3.2	3.2	1.4	4.0	8.0	Q3
TPS3808G18QDBVRQ1	SOT-23	DBV	6	3000	179.0	8.4	3.2	3.2	1.4	4.0	8.0	Q3
TPS3808G30QDBVRQ1	SOT-23	DBV	6	3000	179.0	8.4	3.2	3.2	1.4	4.0	8.0	Q3
TPS3808G33QDBVRQ1	SOT-23	DBV	6	3000	179.0	8.4	3.2	3.2	1.4	4.0	8.0	Q3
TPS3808G50QDBVRQ1	SOT-23	DBV	6	3000	179.0	8.4	3.2	3.2	1.4	4.0	8.0	Q3

**TAPE AND REEL BOX DIMENSIONS**



\*All dimensions are nominal

Device	Package Type	Package Drawing	Pins	SPQ	Length (mm)	Width (mm)	Height (mm)
TPS3808G01QDBVRQ1	SOT-23	DBV	6	3000	203.0	203.0	35.0
TPS3808G01QDRVRQ1	WSON	DRV	6	3000	210.0	185.0	35.0
TPS3808G125QDBVRQ1	SOT-23	DBV	6	3000	203.0	203.0	35.0
TPS3808G12QDBVRQ1	SOT-23	DBV	6	3000	203.0	203.0	35.0
TPS3808G15QDBVRQ1	SOT-23	DBV	6	3000	203.0	203.0	35.0
TPS3808G18QDBVRQ1	SOT-23	DBV	6	3000	203.0	203.0	35.0
TPS3808G30QDBVRQ1	SOT-23	DBV	6	3000	203.0	203.0	35.0
TPS3808G33QDBVRQ1	SOT-23	DBV	6	3000	203.0	203.0	35.0
TPS3808G50QDBVRQ1	SOT-23	DBV	6	3000	203.0	203.0	35.0

# MECHANICAL DATA

DBV (R-PDSO-G6)

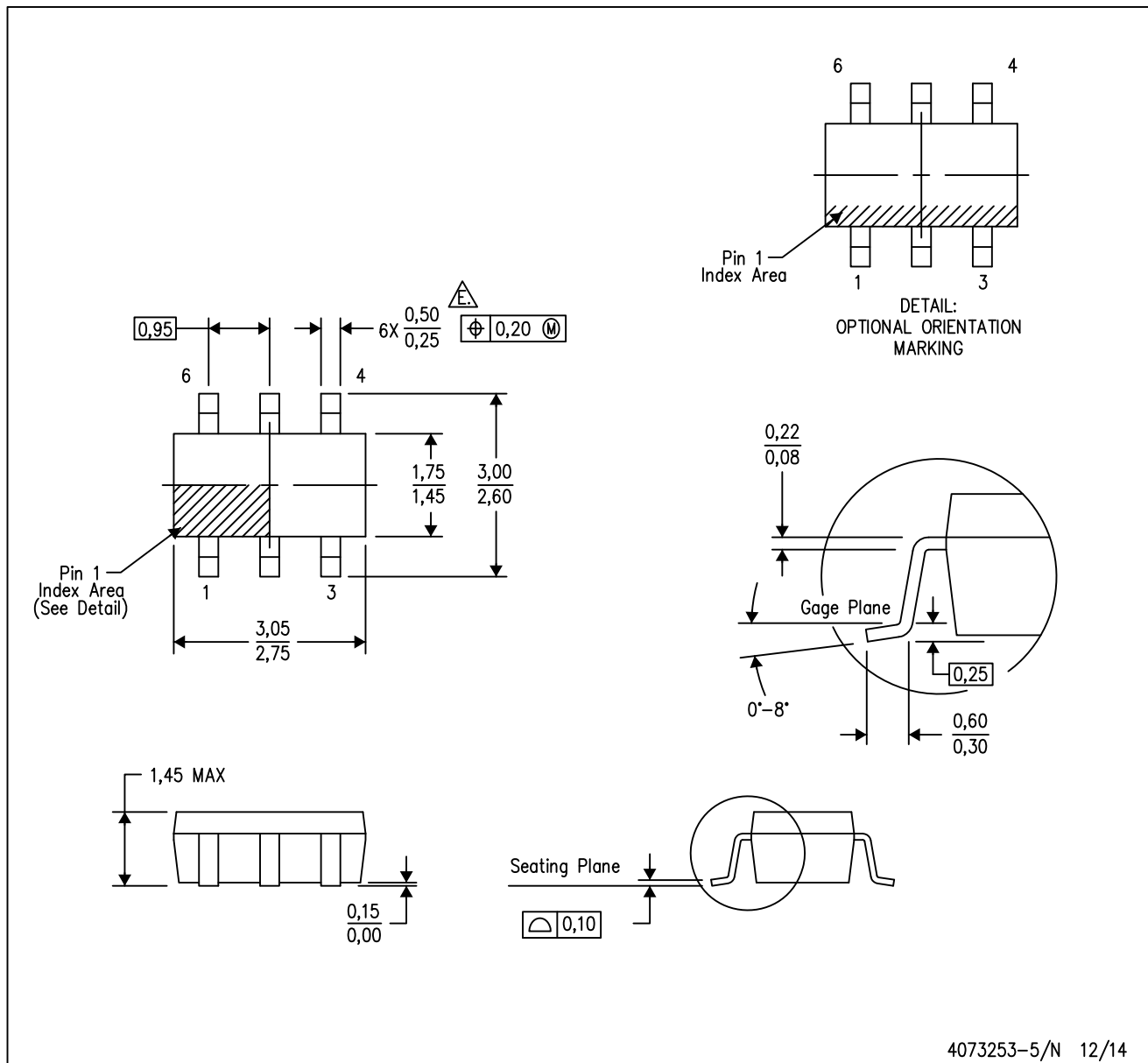
PLASTIC SMALL-OUTLINE PACKAGE



- NOTES:
- A. All linear dimensions are in millimeters.
  - B. This drawing is subject to change without notice.
  - C. Body dimensions do not include mold flash or protrusion. Mold flash and protrusion shall not exceed 0.15 per side.
  - D. Leads 1,2,3 may be wider than leads 4,5,6 for package orientation.
- Falls within JEDEC MO-178 Variation AB, except minimum lead width.

DBV (R-PDSO-G6)

PLASTIC SMALL OUTLINE



- NOTES:
- A. All linear dimensions are in millimeters.
  - B. This drawing is subject to change without notice.
  - C. Customers should place a note on the circuit board fabrication drawing not to alter the center solder mask defined pad.
  - D. Publication IPC-7351 is recommended for alternate designs.
  - E. Laser cutting apertures with trapezoidal walls and also rounding corners will offer better paste release. Customers should contact their board assembly site for stencil design recommendations. Example stencil design based on a 50% volumetric metal load solder paste. Refer to IPC-7525 for other stencil recommendations.

# MECHANICAL DATA

DRV (S-PWSON-N6)

PLASTIC SMALL OUTLINE NO-LEAD

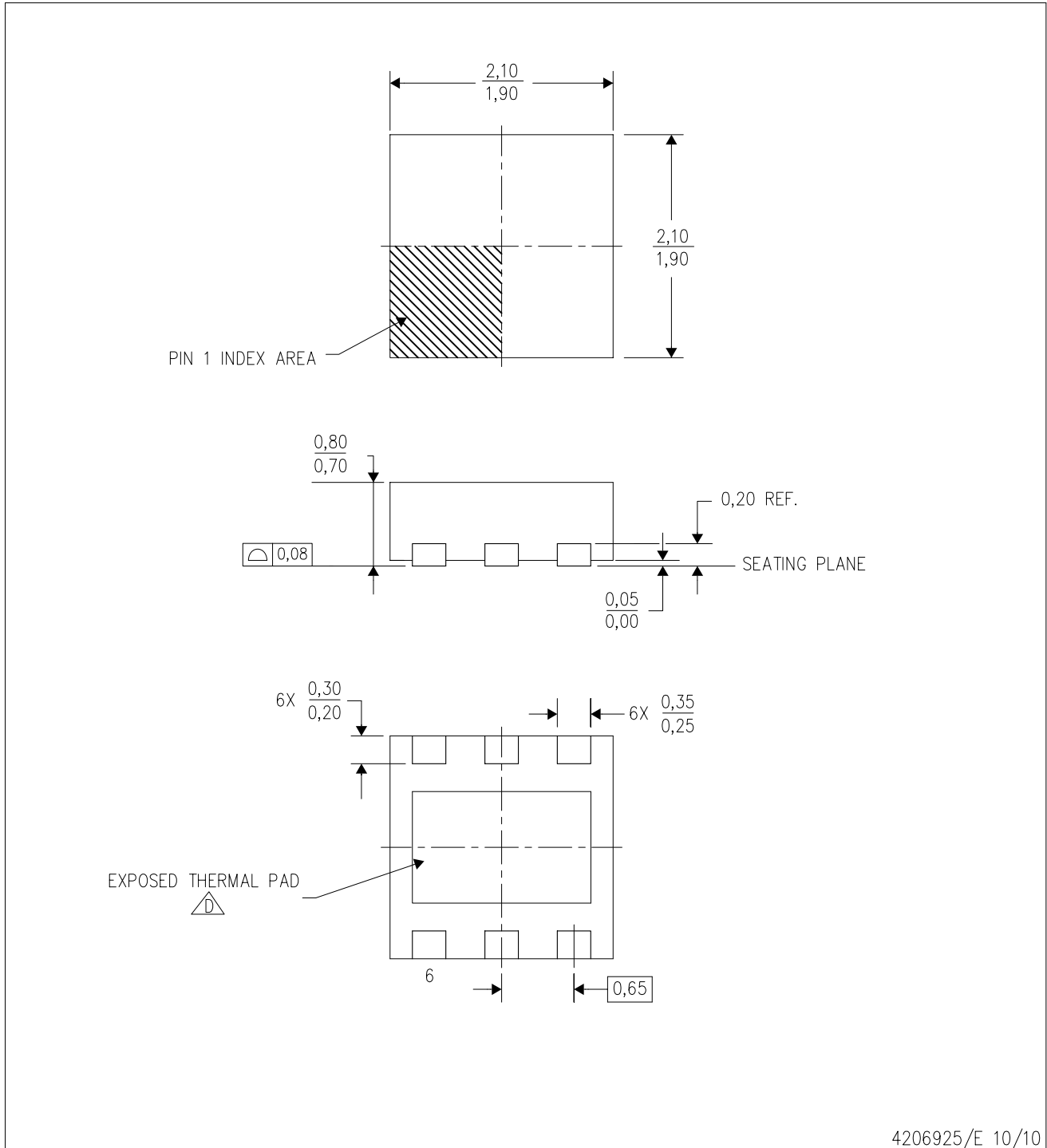

4206925/E 10/10

- NOTES:
- All linear dimensions are in millimeters. Dimensioning and tolerancing per ASME Y14.5M-1994.
  - This drawing is subject to change without notice.
  - Small Outline No-Lead (SON) package configuration.
- (D) The package thermal pad must be soldered to the board for thermal and mechanical performance. See the Product Data Sheet for details regarding the exposed thermal pad dimensions.

## THERMAL PAD MECHANICAL DATA

DRV (S-PWSON-N6)

PLASTIC SMALL OUTLINE NO-LEAD

### THERMAL INFORMATION

This package incorporates an exposed thermal pad that is designed to be attached directly to an external heatsink. The thermal pad must be soldered directly to the printed circuit board (PCB). After soldering, the PCB can be used as a heatsink. In addition, through the use of thermal vias, the thermal pad can be attached directly to the appropriate copper plane shown in the electrical schematic for the device, or alternatively, can be attached to a special heatsink structure designed into the PCB. This design optimizes the heat transfer from the integrated circuit (IC).

For information on the Quad Flatpack No-Lead (QFN) package and its advantages, refer to Application Report, QFN/SON PCB Attachment, Texas Instruments Literature No. SLUA271. This document is available at [www.ti.com](http://www.ti.com).

The exposed thermal pad dimensions for this package are shown in the following illustration.

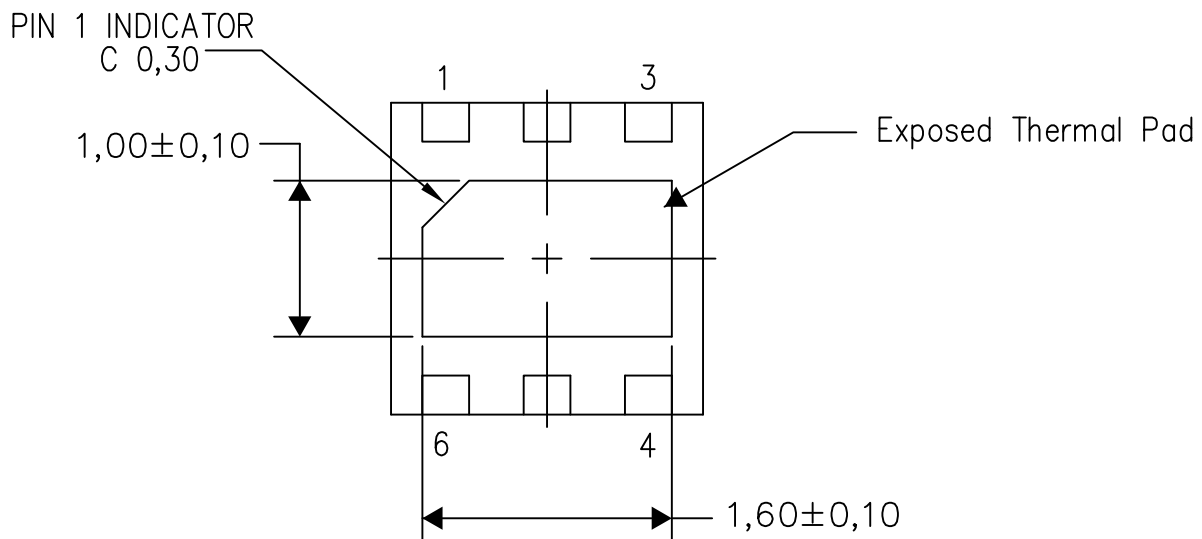

Bottom View

Exposed Thermal Pad Dimensions

4206926/Q 04/15

NOTE: All linear dimensions are in millimeters

DRV (S-PWSON-N6)

PLASTIC SMALL OUTLINE NO-LEAD

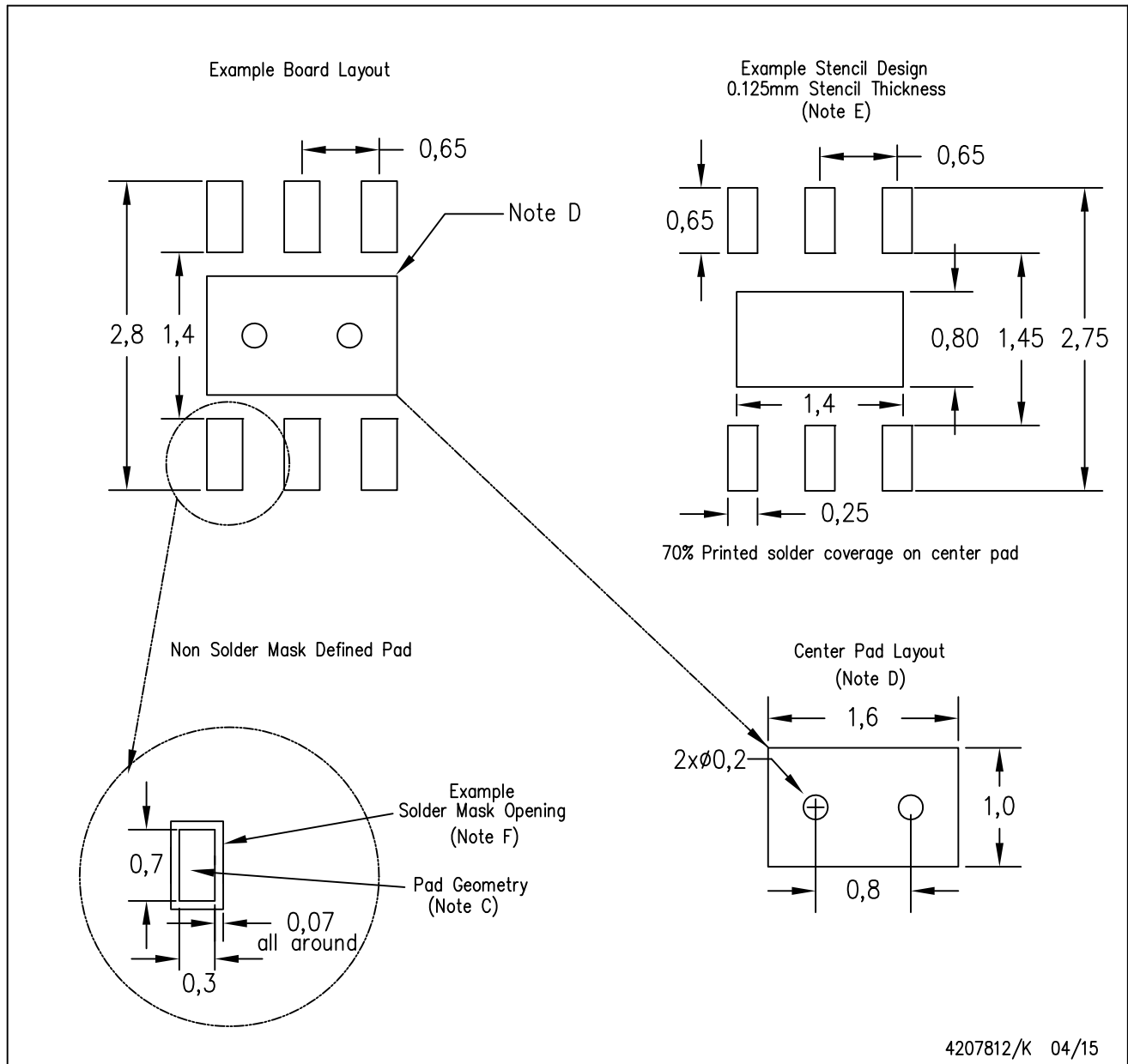

- NOTES:
- A. All linear dimensions are in millimeters.
  - B. This drawing is subject to change without notice.
  - C. Publication IPC-7351 is recommended for alternate designs.
  - D. This package is designed to be soldered to a thermal pad on the board. Refer to Application Note, QFN/SON PCB Attachment, Texas Instruments Literature No. SLUA271, and also the Product Data Sheets for specific thermal information, via requirements, and recommended board layout. These documents are available at [www.ti.com](http://www.ti.com) <<http://www.ti.com>>.
  - E. Laser cutting apertures with trapezoidal walls and also rounding corners will offer better paste release. Customers should contact their board assembly site for stencil design recommendations. Refer to IPC 7525 for stencil design considerations.
  - F. Customers should contact their board fabrication site for solder mask tolerances.



## IMPORTANT NOTICE

Texas Instruments Incorporated and its subsidiaries (TI) reserve the right to make corrections, enhancements, improvements and other changes to its semiconductor products and services per JESD46, latest issue, and to discontinue any product or service per JESD48, latest issue. Buyers should obtain the latest relevant information before placing orders and should verify that such information is current and complete. All semiconductor products (also referred to herein as "components") are sold subject to TI's terms and conditions of sale supplied at the time of order acknowledgment.

TI warrants performance of its components to the specifications applicable at the time of sale, in accordance with the warranty in TI's terms and conditions of sale of semiconductor products. Testing and other quality control techniques are used to the extent TI deems necessary to support this warranty. Except where mandated by applicable law, testing of all parameters of each component is not necessarily performed.

TI assumes no liability for applications assistance or the design of Buyers' products. Buyers are responsible for their products and applications using TI components. To minimize the risks associated with Buyers' products and applications, Buyers should provide adequate design and operating safeguards.

TI does not warrant or represent that any license, either express or implied, is granted under any patent right, copyright, mask work right, or other intellectual property right relating to any combination, machine, or process in which TI components or services are used. Information published by TI regarding third-party products or services does not constitute a license to use such products or services or a warranty or endorsement thereof. Use of such information may require a license from a third party under the patents or other intellectual property of the third party, or a license from TI under the patents or other intellectual property of TI.

Reproduction of significant portions of TI information in TI data books or data sheets is permissible only if reproduction is without alteration and is accompanied by all associated warranties, conditions, limitations, and notices. TI is not responsible or liable for such altered documentation. Information of third parties may be subject to additional restrictions.

Resale of TI components or services with statements different from or beyond the parameters stated by TI for that component or service voids all express and any implied warranties for the associated TI component or service and is an unfair and deceptive business practice. TI is not responsible or liable for any such statements.

Buyer acknowledges and agrees that it is solely responsible for compliance with all legal, regulatory and safety-related requirements concerning its products, and any use of TI components in its applications, notwithstanding any applications-related information or support that may be provided by TI. Buyer represents and agrees that it has all the necessary expertise to create and implement safeguards which anticipate dangerous consequences of failures, monitor failures and their consequences, lessen the likelihood of failures that might cause harm and take appropriate remedial actions. Buyer will fully indemnify TI and its representatives against any damages arising out of the use of any TI components in safety-critical applications.

In some cases, TI components may be promoted specifically to facilitate safety-related applications. With such components, TI's goal is to help enable customers to design and create their own end-product solutions that meet applicable functional safety standards and requirements. Nonetheless, such components are subject to these terms.

No TI components are authorized for use in FDA Class III (or similar life-critical medical equipment) unless authorized officers of the parties have executed a special agreement specifically governing such use.

Only those TI components which TI has specifically designated as military grade or "enhanced plastic" are designed and intended for use in military/aerospace applications or environments. Buyer acknowledges and agrees that any military or aerospace use of TI components which have **not** been so designated is solely at the Buyer's risk, and that Buyer is solely responsible for compliance with all legal and regulatory requirements in connection with such use.

TI has specifically designated certain components as meeting ISO/TS16949 requirements, mainly for automotive use. In any case of use of non-designated products, TI will not be responsible for any failure to meet ISO/TS16949.

### Products

Audio	<a href="http://www.ti.com/audio">www.ti.com/audio</a>
Amplifiers	<a href="http://amplifier.ti.com">amplifier.ti.com</a>
Data Converters	<a href="http://dataconverter.ti.com">dataconverter.ti.com</a>
DLP® Products	<a href="http://www.dlp.com">www.dlp.com</a>
DSP	<a href="http://dsp.ti.com">dsp.ti.com</a>
Clocks and Timers	<a href="http://www.ti.com/clocks">www.ti.com/clocks</a>
Interface	<a href="http://interface.ti.com">interface.ti.com</a>
Logic	<a href="http://logic.ti.com">logic.ti.com</a>
Power Mgmt	<a href="http://power.ti.com">power.ti.com</a>
Microcontrollers	<a href="http://microcontroller.ti.com">microcontroller.ti.com</a>
RFID	<a href="http://www.ti-rfid.com">www.ti-rfid.com</a>
OMAP Applications Processors	<a href="http://www.ti.com/omap">www.ti.com/omap</a>
Wireless Connectivity	<a href="http://www.ti.com/wirelessconnectivity">www.ti.com/wirelessconnectivity</a>

### Applications

Automotive and Transportation	<a href="http://www.ti.com/automotive">www.ti.com/automotive</a>
Communications and Telecom	<a href="http://www.ti.com/communications">www.ti.com/communications</a>
Computers and Peripherals	<a href="http://www.ti.com/computers">www.ti.com/computers</a>
Consumer Electronics	<a href="http://www.ti.com/consumer-apps">www.ti.com/consumer-apps</a>
Energy and Lighting	<a href="http://www.ti.com/energy">www.ti.com/energy</a>
Industrial	<a href="http://www.ti.com/industrial">www.ti.com/industrial</a>
Medical	<a href="http://www.ti.com/medical">www.ti.com/medical</a>
Security	<a href="http://www.ti.com/security">www.ti.com/security</a>
Space, Avionics and Defense	<a href="http://www.ti.com/space-avionics-defense">www.ti.com/space-avionics-defense</a>
Video and Imaging	<a href="http://www.ti.com/video">www.ti.com/video</a>

### TI E2E Community

[e2e.ti.com](http://e2e.ti.com)