

TPS22810-Q1, 2.7-18-V, 79-mΩ On-Resistance Load Switch With Thermal Protection

1 Features

- Qualified for Automotive Applications
- AEC-Q100 Qualified With the Following Results:
 - Device Temperature Grade 2: -40°C to $+105^{\circ}\text{C}$ Ambient Operating Temperature
 - Device HBM ESD Classification Level 2
 - Device CDM ESD Classification Level C5
- Integrated Single Channel Load Switch
- 2-A Maximum Continuous Current
- Input Voltage: 2.7 V to 18 V
- Absolute Maximum Input Voltage: 20 V
- On-Resistance (R_{ON})
 - $R_{\text{ON}} = 79\text{ m}\Omega$ (Typical) at $V_{\text{IN}} = 12\text{ V}$
- Quiescent Current
 - $62\text{ }\mu\text{A}$ (Typical) at $V_{\text{IN}} = 12\text{ V}$
- Shutdown Current
 - 500 nA (Typical) at $V_{\text{IN}} = 12\text{ V}$
- Thermal Shutdown
- Undervoltage Lock-Out (UVLO)
- Adjustable Quick Output Discharge (QOD)
- Configurable Rise Time With CT Pin
- SOT23-6 Package
 - 2.9-mm \times 2.8-mm, 0.95-mm Pitch, 1.45-mm Height (DBV)

2 Applications

- Automotive Head Unit
- Surround View ECU

3 Description

The TPS22810-Q1 is a one channel load switch with configurable rise time and integrated quick output discharge (QOD). The device features thermal shutdown to protect the device against high junction temperature and thereby ensure safe operating area of the device inherently. The device features a N-channel MOSFET that can operate over an input voltage range of 2.7 V to 18 V. The device can support a maximum current of 2 A. The switch is controlled by an on and off input that can interface directly with low-voltage control signals.

The configurable rise time of the device greatly reduces inrush current caused by large bulk load capacitances, thereby reducing or eliminating power supply droop. Undervoltage lock-out is used to turn off the device if the V_{IN} voltage drops below a threshold value, ensuring that the downstream circuitry is not damaged by being supplied by a voltage lower than intended. The configurable QOD pin controls the fall time of the device to allow design flexibility for power down.

The TPS22810-Q1 is available in a leaded, SOT-23 package (DBV) which allows to visually inspect solder joints. The device is characterized for operation over the free-air temperature range of -40°C to $+105^{\circ}\text{C}$.

Device Information⁽¹⁾

PART NUMBER	PACKAGE	BODY SIZE (NOM)
TPS22810-Q1	SOT-23 (6)	2.90 mm \times 2.80 mm

(1) For all available packages, see the orderable addendum at the end of the data sheet.

Simplified Schematic

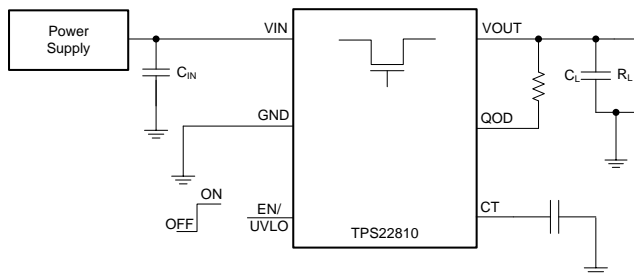

Table of Contents

1 Features	1	8.4 Device Functional Modes.....	15
2 Applications	1	9 Application and Implementation	16
3 Description	1	9.1 Application Information.....	16
4 Revision History	2	9.2 Typical Application	16
5 Pin Configuration and Functions	3	10 Power Supply Recommendations	21
6 Specifications	4	11 Layout	22
6.1 Absolute Maximum Ratings	4	11.1 Layout Guidelines	22
6.2 ESD Ratings.....	4	11.2 Layout Example	22
6.3 Recommended Operating Conditions.....	4	11.3 Thermal Considerations	22
6.4 Thermal Information	4	12 Device and Documentation Support	23
6.5 Electrical Characteristics.....	5	12.1 Device Support.....	23
6.6 Switching Characteristics	6	12.2 Documentation Support	23
6.7 Typical DC Characteristics	7	12.3 Receiving Notification of Documentation Updates	23
6.8 Typical AC Characteristics.....	8	12.4 Community Resources.....	23
7 Parameter Measurement Information	10	12.5 Trademarks	23
8 Detailed Description	11	12.6 Electrostatic Discharge Caution.....	23
8.1 Overview	11	12.7 Glossary	23
8.2 Functional Block Diagram	11	13 Mechanical, Packaging, and Orderable	23
8.3 Feature Description.....	12	Information	23

4 Revision History

DATE	REVISION	NOTES
April 2018	*	Initial release.

5 Pin Configuration and Functions

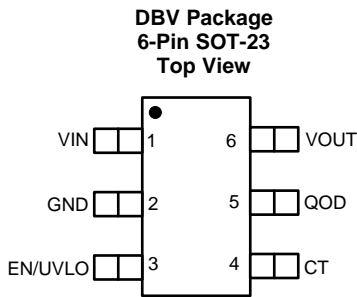

Pin Functions

PIN		I/O	DESCRIPTION
NAME	NO.		
CT	4	O	Switch slew rate control. Can be left floating
EN/UVLO	3	I	Active high switch control input and UVLO adjustment. Do not leave floating
GND	2	—	Device ground
QOD	5	O	Quick Output Discharge pin. This functionality can be enabled in one of three ways: <ul style="list-style-type: none"> • Placing an external resistor between VOUT and QOD • Tying QOD directly to VOUT and using the internal resistor value (R_{PD}) • Disabling QOD by leaving pin floating See the Quick Output Discharge (QOD) for more information
VIN	1	I	Switch input. Place ceramic bypass capacitor(s) between this pin and GND
VOUT	6	O	Switch output

6 Specifications

6.1 Absolute Maximum Ratings

over operating free-air temperature range (unless otherwise noted)⁽¹⁾

			MIN	MAX	UNIT
V _{IN}	Maximum Input Voltage Range	V _{IN}	-0.3	20	V
V _{OUT}	Maximum Output Voltage Range	V _{OUT}	-0.3	min (20V, V _{IN} + 0.3)	
V _{EN/UVLO}	Maximum Enable Pin Voltage Range	EN/UVLO	-0.3	20	V
T _J	Junction temperature			150	°C
T _{stg}	Storage temperature		-65	150	°C

(1) Stresses beyond those listed under *Absolute Maximum Rating* may cause permanent damage to the device. These are stress ratings only, which do not imply functional operation of the device at these or any other conditions beyond those indicated under *Recommended Operating Condition*. Exposure to absolute-maximum-rated conditions for extended periods may affect device reliability.

6.2 ESD Ratings

			VALUE	UNIT	
V _(ESD)	Electrostatic discharge	Human body model (HBM), per AEC Q100-002 ⁽¹⁾	±3000	V	
		Charged device model (CDM), per AEC Q100-011	Corner pins (V _{IN} , V _{OUT} , EN/UVLO, and CT)		±750
			Other pins		±1000

(1) AEC Q100-002 indicates that HBM stressing shall be in accordance with the ANSI/ESDA/JEDEC JS-001 specification.

6.3 Recommended Operating Conditions

over operating free-air temperature range (unless otherwise noted)

			MIN	MAX	UNIT
V _{IN}	Input Voltage Range	IN	2.7	18	V
V _{OUT}	Output Voltage Range	OUT		V _{IN}	V
V _{EN/UVLO}	Enable Pin Voltage Range	EN/UVLO	0	18	V
I _{MAX}	Maximum continuous switch current, T _A = 65°C	IN to OUT		2	A
I _{MAX}	Maximum continuous switch current, T _A = 85°C	IN to OUT		1.5	A
I _{MAX}	Maximum continuous switch current, T _A = 105°C	IN to OUT		1	A
T _A	Operating free-air temperature		-40	105	°C
C _{IN}	Input Capacitor ⁽¹⁾		1		μF

(1) See the Detailed Description section.

6.4 Thermal Information

THERMAL METRIC ⁽¹⁾		TPS22810-Q1	UNIT
		DBV (SOT23)	
		6 PINS	
R _{θJA}	Junction-to-ambient thermal resistance	182	°C/W
R _{θJC(top)}	Junction-to-case (top) thermal resistance	127.2	°C/W
R _{θJB}	Junction-to-board thermal resistance	16.9	°C/W
Ψ _{JT}	Junction-to-top characterization parameter	26.4	°C/W
Ψ _{JB}	Junction-to-board characterization parameter	36.3	°C/W

(1) For more information about traditional and new thermal metrics, see the [Semiconductor and IC Package Thermal Metrics](#) application report.

6.5 Electrical Characteristics

Unless otherwise noted, the specification in the following table applies over the following ambient operating temperature $-40^{\circ}\text{C} \leq T_A \leq +105^{\circ}\text{C}$. Typical values are for $T_A = 25^{\circ}\text{C}$.

PARAMETER		TEST CONDITIONS		MIN	TYP	MAX	UNIT
$I_{Q, VIN}$	Quiescent current	$I_{OUT} = 0\text{ A}$	$V_{IN} = 18\text{ V}$	$T_A = -40^{\circ}\text{C to } +85^{\circ}\text{C}$	62	80	μA
				$T_A = -40^{\circ}\text{C to } +105^{\circ}\text{C}$		85	
			$V_{IN} = 12\text{ V}$	$T_A = -40^{\circ}\text{C to } +85^{\circ}\text{C}$	62	80	
				$T_A = -40^{\circ}\text{C to } +105^{\circ}\text{C}$		85	
			$V_{IN} = 5\text{ V}$	$T_A = -40^{\circ}\text{C to } +85^{\circ}\text{C}$	59	80	
				$T_A = -40^{\circ}\text{C to } +105^{\circ}\text{C}$		85	
			$V_{IN} = 3.3\text{ V}$	$T_A = -40^{\circ}\text{C to } +85^{\circ}\text{C}$	53	80	
				$T_A = -40^{\circ}\text{C to } +105^{\circ}\text{C}$		85	
			$V_{IN} = 2.7\text{ V}$	$T_A = -40^{\circ}\text{C to } +85^{\circ}\text{C}$	49	70	
				$T_A = -40^{\circ}\text{C to } +105^{\circ}\text{C}$		85	
$I_{SD, VIN}$	Shutdown current	$V_{EN} = 0\text{ V}, V_{OUT} = 0\text{ V}$	$V_{IN} = 18\text{ V}$	$T_A = -40^{\circ}\text{C to } +85^{\circ}\text{C}$	0.5	2.3	μA
				$T_A = -40^{\circ}\text{C to } +105^{\circ}\text{C}$		3.8	
			$V_{IN} = 12\text{ V}$	$T_A = -40^{\circ}\text{C to } +85^{\circ}\text{C}$	0.5	2.3	
				$T_A = -40^{\circ}\text{C to } +105^{\circ}\text{C}$		3.8	
			$V_{IN} = 5\text{ V}$	$T_A = -40^{\circ}\text{C to } +85^{\circ}\text{C}$	0.5	2.3	
				$T_A = -40^{\circ}\text{C to } +105^{\circ}\text{C}$		3.8	
			$V_{IN} = 3.3\text{ V}$	$T_A = -40^{\circ}\text{C to } +85^{\circ}\text{C}$	0.5	2.3	
				$T_A = -40^{\circ}\text{C to } +105^{\circ}\text{C}$		3.8	
			$V_{IN} = 2.7\text{ V}$	$T_A = -40^{\circ}\text{C to } +85^{\circ}\text{C}$	0.5	2.3	
				$T_A = -40^{\circ}\text{C to } +105^{\circ}\text{C}$		3.8	
$I_{EN/UVLO}$	EN/UVLO pin input leakage current	$V_{IN} = 18\text{ V}, I_{OUT} = 0\text{ A}$	$T_A = -40^{\circ}\text{C to } +105^{\circ}\text{C}$			0.1	μA
V_{UVR}	VIN UVLO threshold, rising		$T_A = -40^{\circ}\text{C to } +105^{\circ}\text{C}$	2	2.54	2.62	V
$V_{UVRhyst}$	VIN UVLO hysteresis		$T_A = -40^{\circ}\text{C to } +105^{\circ}\text{C}$		5		%
V_{ENR}	EN threshold, rising		$T_A = -40^{\circ}\text{C to } +105^{\circ}\text{C}$	1.13	1.23	1.3	V
V_{ENF}	EN threshold, falling		$T_A = -40^{\circ}\text{C to } +105^{\circ}\text{C}$	1.08	1.13	1.18	V
V_{SHUTF}	EN threshold voltage for low I_Q shutdown		$T_A = -40^{\circ}\text{C to } +105^{\circ}\text{C}$	0.5	0.75	0.9	V
R_{ON}	On-resistance		$V_{IN} = 18\text{ V}, I_{OUT} = -200\text{ mA}$	$T_A = 25^{\circ}\text{C}$	79	86	$\text{m}\Omega$
				$T_A = -40^{\circ}\text{C to } +85^{\circ}\text{C}$		105	
				$T_A = -40^{\circ}\text{C to } +105^{\circ}\text{C}$		115	
			$V_{IN} = 12\text{ V}, I_{OUT} = -200\text{ mA}$	$T_A = 25^{\circ}\text{C}$	79	86	
				$T_A = -40^{\circ}\text{C to } +85^{\circ}\text{C}$		105	
				$T_A = -40^{\circ}\text{C to } +105^{\circ}\text{C}$		115	
			$V_{IN} = 9\text{ V}, I_{OUT} = -200\text{ mA}$	$T_A = 25^{\circ}\text{C}$	79	86	
				$T_A = -40^{\circ}\text{C to } +85^{\circ}\text{C}$		105	
				$T_A = -40^{\circ}\text{C to } +105^{\circ}\text{C}$		115	
			$V_{IN} = 5\text{ V}, I_{OUT} = -200\text{ mA}$	$T_A = 25^{\circ}\text{C}$	79	86	
				$T_A = -40^{\circ}\text{C to } +85^{\circ}\text{C}$		105	
				$T_A = -40^{\circ}\text{C to } +105^{\circ}\text{C}$		115	
			$V_{IN} = 3.3\text{ V}, I_{OUT} = -200\text{ mA}$	$T_A = 25^{\circ}\text{C}$	83	92	
				$T_A = -40^{\circ}\text{C to } +85^{\circ}\text{C}$		115	
				$T_A = -40^{\circ}\text{C to } +105^{\circ}\text{C}$		125	
			$V_{IN} = 2.7\text{ V}, I_{OUT} = -200\text{ mA}$	$T_A = 25^{\circ}\text{C}$	86	95	
				$T_A = -40^{\circ}\text{C to } +85^{\circ}\text{C}$		120	
				$T_A = -40^{\circ}\text{C to } +105^{\circ}\text{C}$		130	

Electrical Characteristics (continued)

Unless otherwise noted, the specification in the following table applies over the following ambient operating temperature $-40^{\circ}\text{C} \leq T_A \leq +105^{\circ}\text{C}$. Typical values are for $T_A = 25^{\circ}\text{C}$.

PARAMETER	TEST CONDITIONS	MIN	TYP	MAX	UNIT
R _{PD} Output pull down resistance	V _{IN} = V _{OUT} = 18 V, V _{EN/UVLO} = 0 V, T _A = -40°C to +105°C		290	350	Ω
	V _{IN} = V _{OUT} = 12 V, V _{EN/UVLO} = 0 V, T _A = -40°C to +105°C		265	350	
	V _{IN} = V _{OUT} = 5 V, V _{EN/UVLO} = 0 V, T _A = -40°C to +105°C		250	400	
T _{SD} Thermal shutdown threshold	V _{IN} = 18 V, T _A = -40°C to +105°C		160		°C
T _{SD,HYS} Thermal shutdown hysteresis	V _{IN} = 18 V, T _A = -40°C to +105°C		30		°C

6.6 Switching Characteristics

Refer to the timing test circuit in [Figure 16](#) (unless otherwise noted) for references to external components used for the test condition in the switching characteristics table. Switching characteristics shown below are only valid for the power-up sequence where V_{IN} is already in steady state condition before the EN/UVLO pin is asserted high.

PARAMETER	TEST CONDITIONS	MIN	TYP	MAX	UNIT
V_{IN} = 18 V, V_{EN/UVLO} = 5 V, T_A = 25 °C (unless otherwise noted)					
t _{ON} Turnon time	R _L = 10 Ω, C _{IN} = 1 μF, C _L = 0.1 μF, C _T = 2200 pF		520		μs
t _{OFF} Turnoff time	R _L = 10 Ω, C _{IN} = 1 μF, C _L = 0.1 μF, C _T = 2200 pF		3.3		
t _R V _{OUT} rise time	R _L = 10 Ω, C _{IN} = 1 μF, C _L = 0.1 μF, C _T = 2200 pF		700		
t _F V _{OUT} fall time	R _L = 10 Ω, C _{IN} = 1 μF, C _L = 0.1 μF, C _T = 2200 pF		2		
t _D Delay time	R _L = 10 Ω, C _{IN} = 1 μF, C _L = 0.1 μF, C _T = 2200 pF		180		
V_{IN} = 12 V, V_{EN/UVLO} = 5 V, T_A = 25 °C (unless otherwise noted)					
t _{ON} Turnon time	R _L = 10 Ω, C _{IN} = 1 μF, C _L = 0.1 μF, C _T = 2200 pF		380		μs
t _{OFF} Turnoff time	R _L = 10 Ω, C _{IN} = 1 μF, C _L = 0.1 μF, C _T = 2200 pF		3.3		
t _R V _{OUT} rise time	R _L = 10 Ω, C _{IN} = 1 μF, C _L = 0.1 μF, C _T = 2200 pF		460		
t _F V _{OUT} fall time	R _L = 10 Ω, C _{IN} = 1 μF, C _L = 0.1 μF, C _T = 2200 pF		2		
t _D Delay time	R _L = 10 Ω, C _{IN} = 1 μF, C _L = 0.1 μF, C _T = 2200 pF		150		
V_{IN} = 3.3 V, V_{EN/UVLO} = 5 V, T_A = 25 °C (unless otherwise noted)					
t _{ON} Turnon time	R _L = 10 Ω, C _{IN} = 1 μF, C _L = 0.1 μF, C _T = 2200 pF		185		μs
t _{OFF} Turnoff time	R _L = 10 Ω, C _{IN} = 1 μF, C _L = 0.1 μF, C _T = 2200 pF		3.3		
t _R V _{OUT} rise time	R _L = 10 Ω, C _{IN} = 1 μF, C _L = 0.1 μF, C _T = 2200 pF		120		
t _F V _{OUT} fall time	R _L = 10 Ω, C _{IN} = 1 μF, C _L = 0.1 μF, C _T = 2200 pF		2		
t _D Delay time	R _L = 10 Ω, C _{IN} = 1 μF, C _L = 0.1 μF, C _T = 2200 pF		130		

6.7 Typical DC Characteristics

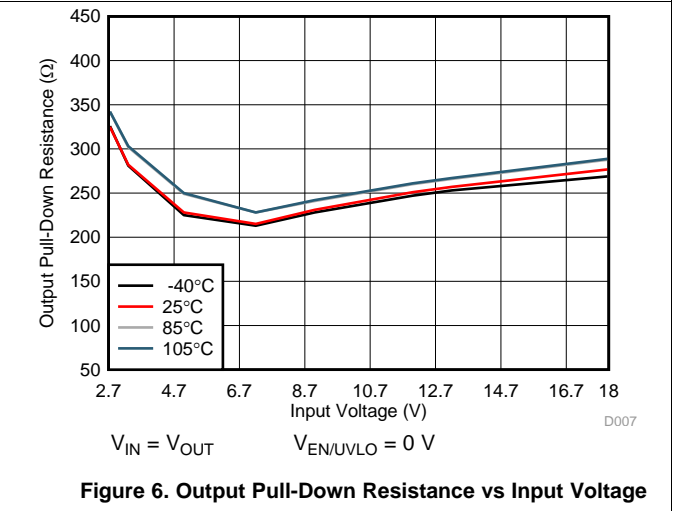
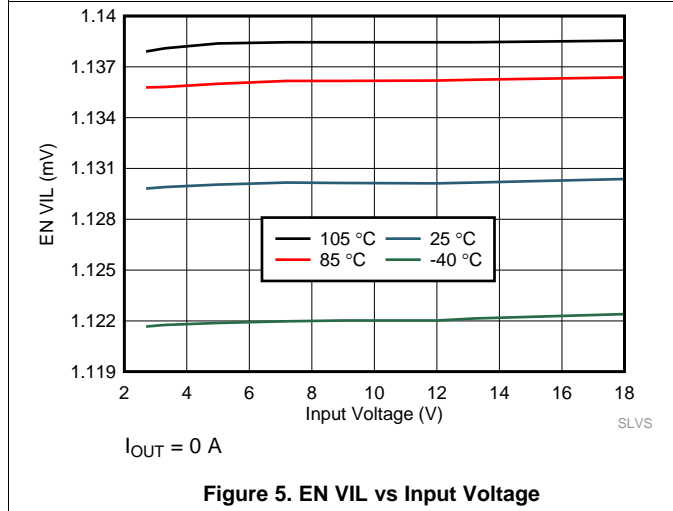
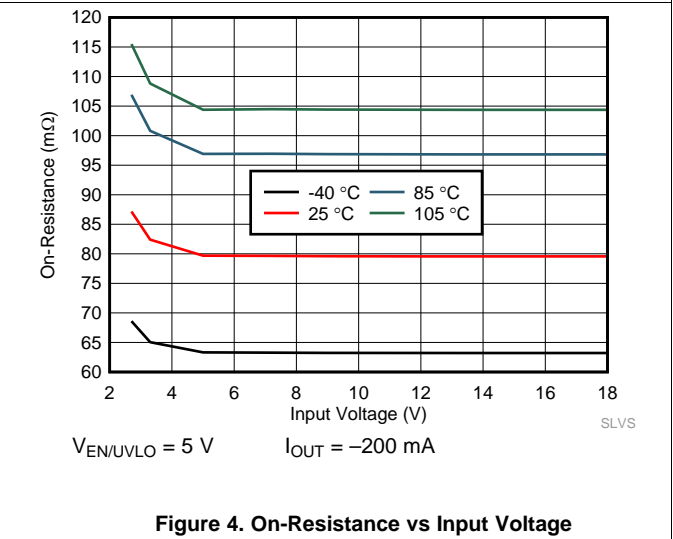
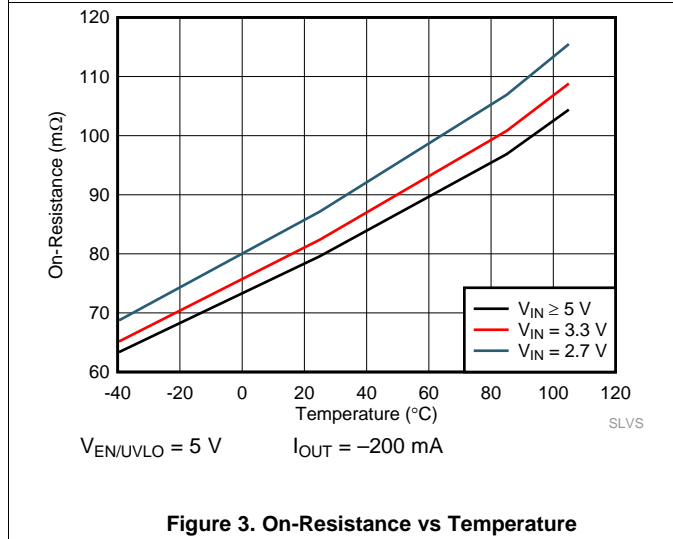
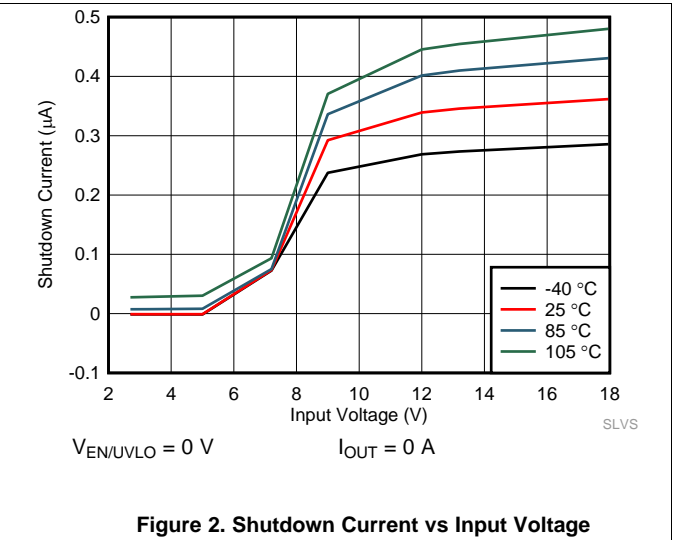
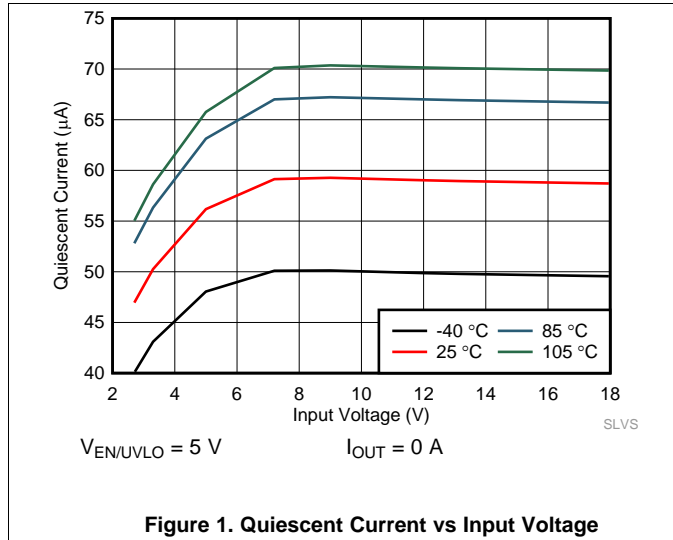

6.8 Typical AC Characteristics

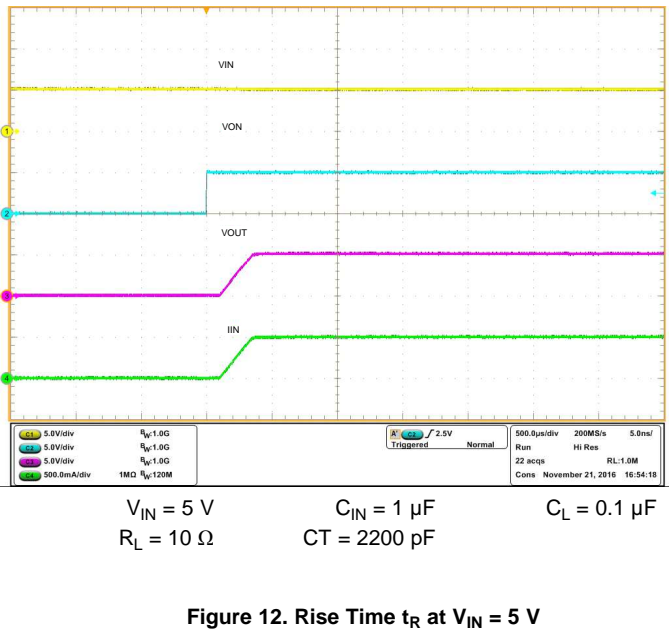
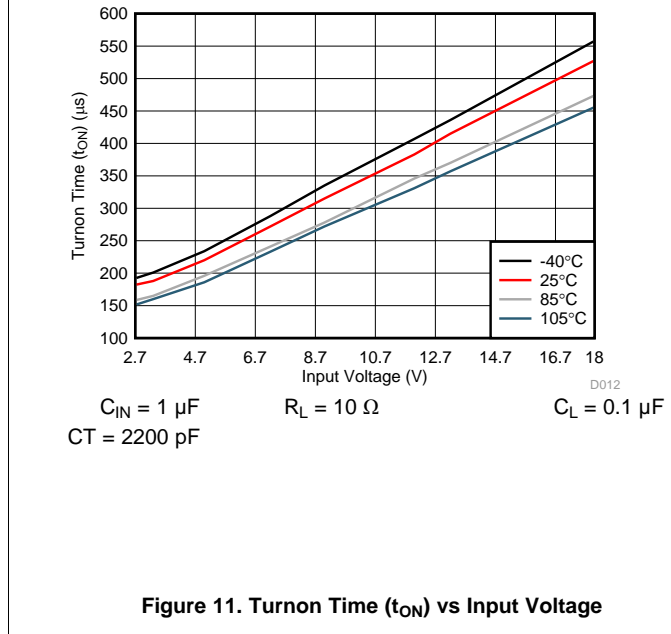
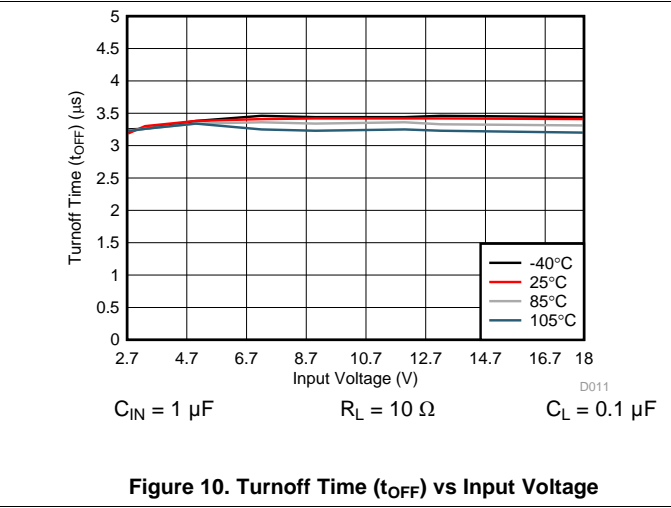
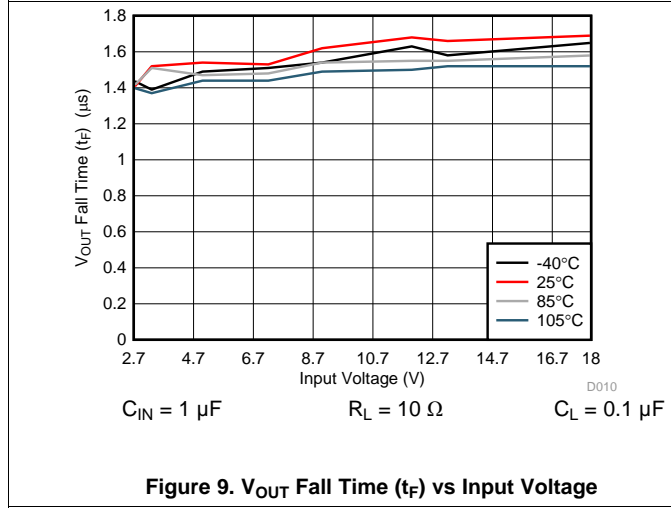
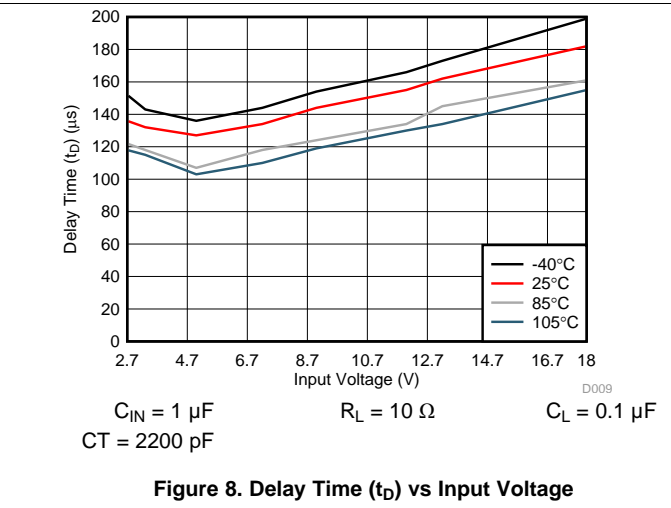
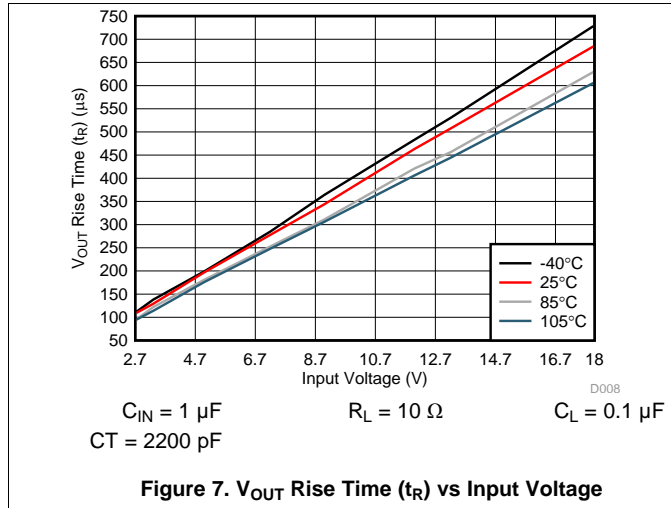

Typical AC Characteristics (continued)

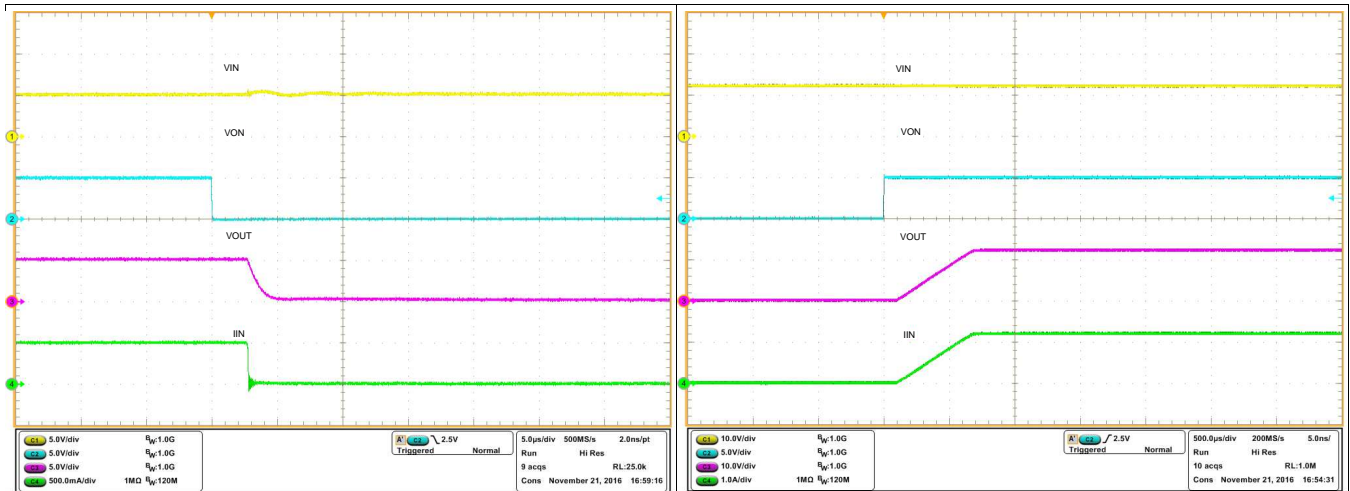

$V_{IN} = 5\text{ V}$ $C_{IN} = 1\ \mu\text{F}$ $C_L = 0.1\ \mu\text{F}$
 $R_L = 10\ \Omega$ QOD = Open

Figure 13. Fall Time t_F at $V_{IN} = 5\text{ V}$

$V_{IN} = 12\text{ V}$ $C_{IN} = 1\ \mu\text{F}$ $C_L = 0.1\ \mu\text{F}$
 $R_L = 10\ \Omega$ CT = 2200 pF

Figure 14. Rise Time t_R at $V_{IN} = 12\text{ V}$

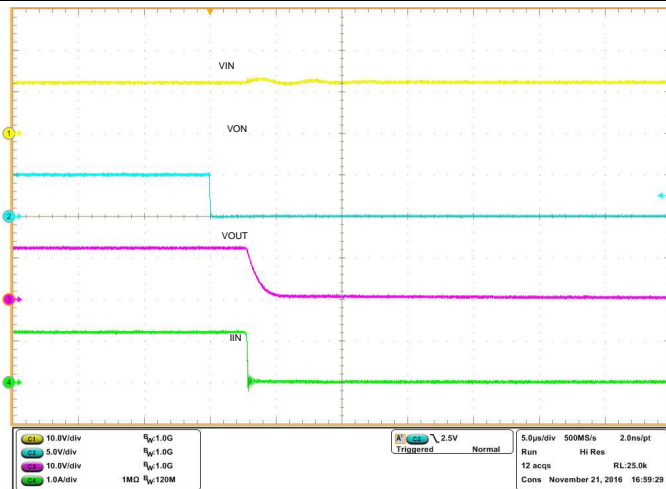

$V_{IN} = 12\text{ V}$ $C_{IN} = 1\ \mu\text{F}$ $C_L = 0.1\ \mu\text{F}$
 $R_L = 10\ \Omega$ QOD = Open

Figure 15. Fall Time t_F at $V_{IN} = 12\text{ V}$

7 Parameter Measurement Information

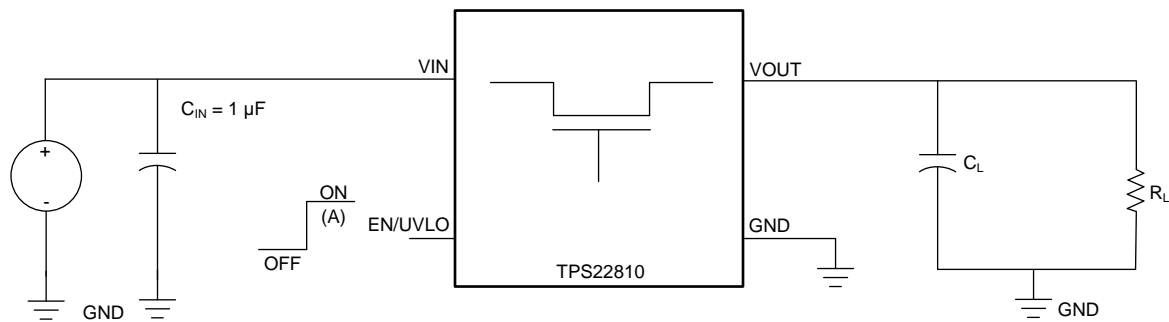

A. Rise and fall times of the control signal are 100 ns

Figure 16. Test Circuit

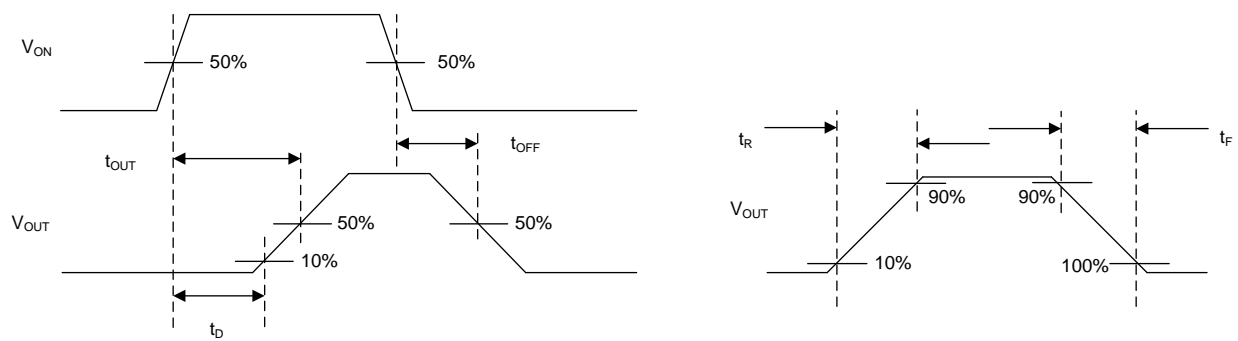

Figure 17. Timing Waveforms

8 Detailed Description

8.1 Overview

The TPS22810-Q1 is a 6-pin, 2.7-18-V load switch with thermal protection. To reduce voltage drop for low voltage and high current rails, the device implements a low resistance N-channel MOSFET which reduces the drop out voltage across the device.

The device starts its operation by monitoring the VIN bus. When VIN exceeds the undervoltage-lockout threshold (V_{UVL}), the device samples the EN/UVLO pin. A high level on this pin enables the internal MOSFET. When VIN rises, the internal MOSFET of the device starts conducting and allow current to flow from VIN to VOUT. When EN/UVLO is held low (below V_{ENF}), internal MOSFET is turned off.

A voltage $V_{EN/UVLO} < V_{ENF}$ on this pin turns off the internal FET, thus disconnecting VIN from VOUT, while voltage below V_{SHUTF} takes the device into shutdown mode, with I_Q less than 1 μ A to ensure minimal power loss.

The device has a configurable slew rate which helps reduce or eliminate power supply droop because of large inrush currents. The device also features a QOD (Quick Output Discharge) pin with an internal pull-down resistance (R_{PD}) which can be used to discharge VOUT once the switch is disabled.

During shutdown, the device has very low leakage currents, thereby reducing unnecessary leakages for downstream modules during standby. Integrated control logic, driver, charge pump, and output discharge FET eliminates the need for any external components which reduces solution size and bill of materials (BOM) count.

The device has a thermal protection feature to protect itself against thermal damage due to overtemperature and overcurrent conditions. Safe Operating Area (SOA) requirements are thus inherently met without any special design consideration by the board designer.

8.2 Functional Block Diagram

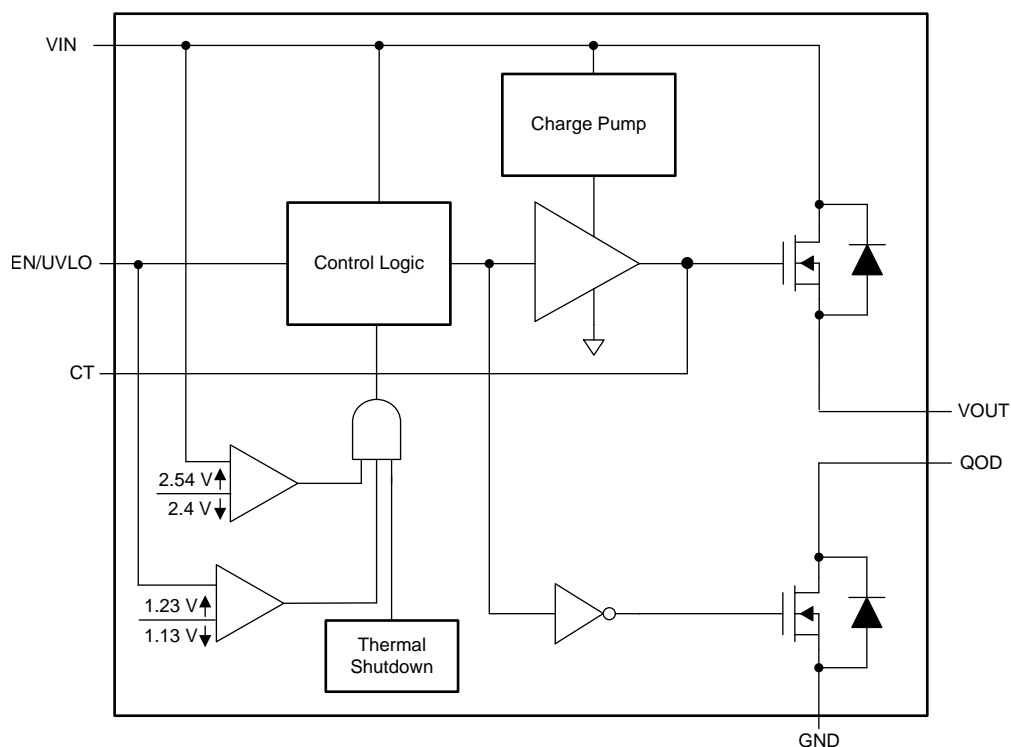

8.3 Feature Description

8.3.1 On and Off Control

The EN/UVLO pin controls the state of the switch. EN/UVLO is active high and has a low threshold that can interface with low-voltage signals. The EN/UVLO pin is compatible with standard GPIO logic threshold. It can be used with any microcontroller with 1.2 V or higher GPIO voltage. This pin cannot be left floating and must be driven either high or low for proper functionality.

8.3.2 Quick Output Discharge (QOD)

The TPS22810-Q1 includes a QOD feature. The QOD pin can be configured in one of three ways:

- QOD pin shorted to VOUT pin. Using this method, the discharge rate after the switch becomes disabled is controlled with the value of the internal pull-down resistance (R_{PD}). The value of this resistance is listed in the [Electrical Characteristics](#) table.
- QOD pin connected to VOUT pin using an external resistor R_{EXT} . After the switch becomes disabled, the discharge rate is controlled by the value of the total resistance of the QOD. To adjust the total QOD resistance, [Equation 1](#) can be used.

$$R_{QOD} = R_{PD} + R_{EXT}$$

where

- R_{QOD} is the total output discharge resistance
- R_{PD} is the internal pulldown resistance
- R_{EXT} is the external resistance placed between the VOUT and QOD pin. (1)
- QOD pin is unused and left floating. Using this method, there is no quick output discharge functionality, and the output remains floating after the switch is disabled.

Note that during thermal shutdown, the QOD functionality is not available. The device does not discharge the load because R_{PD} does not become engaged.

The fall times of the device depend on many factors including the total resistance of the QOD, V_{IN} , and the output capacitance. When QOD is connected to VOUT, the fall time changes over V_{IN} because the internal R_{PD} varies over V_{IN} . To calculate the approximate fall time of V_{OUT} for a given R_{QOD} , use [Equation 2](#) and [Table 1](#).

$$V_{CAP} = V_{IN} \times e^{-t/\tau}$$

where

- V_{CAP} is the voltage across the capacitor (V)
- t is the time since power supply removal (s)
- τ is the time constant equal to $R_{QOD} \times C_L$ (2)

The fall time's dependency on V_{IN} becomes minimal because the QOD value increases with additional external resistance. See [Table 1](#) for QOD fall times.

Table 1. QOD Fall Times

V_{IN} (V)	FALL TIME (μ s) 90% - 10%, $C_{IN} = 1 \mu$ F, $I_{OUT} = 0$ A, $V_{IN} = 0$ V, $ON = 0$ V ⁽¹⁾					
	$T_A = 25^\circ$ C			$T_A = 85^\circ$ C		
	$C_L = 1 \mu$ F	$C_L = 10 \mu$ F	$C_L = 100 \mu$ F	$C_L = 1 \mu$ F	$C_L = 10 \mu$ F	$C_L = 100 \mu$ F
18	470	4700	47000	470	4700	47000
12	450	4500	45000	450	4500	45000
9	440	4400	44000	440	4400	44000
5	500	5000	50000	480	4800	48000
3.3	600	6000	60000	570	5700	57000

(1) TYPICAL VALUES WITH QOD SHORTED TO VOUT

8.3.2.1 QOD when System Power is Removed

The adjustable QOD can be used to control the power down sequencing of a system even when the system power supply is removed. When the power is removed, the input capacitor, C_{IN} , discharges at V_{IN} . Past the set UVLO level, the pull-down resistance R_{PD} becomes disabled and the output no longer becomes discharged. If there is still remaining charge on the output capacitor, this results in longer fall times. Care must be taken such that C_{IN} is large enough to meet the device UVLO settings.

8.3.2.2 Internal QOD Considerations

Special considerations must be taken when using the internal R_{PD} by shorting the QOD pin to the VOUT pin. The internal R_{PD} is a pull-down resistance designed to quickly discharge a load after the switch has been disabled. Care must be used to ensure that excessive current does not flow through R_{PD} during discharge so that the maximum T_J of 125°C is not exceeded. When using only the internal R_{PD} to discharge a load, the total capacitive load must not exceed 200 uF. Otherwise, an external resistor, R_{EXT} must be used to ensure the amount of current flowing through R_{PD} is properly limited and the maximum T_J is not exceeded. To ensure the device is not damaged, the remaining charge from C_L must decay naturally through the internal QOD resistance and must not be driven.

8.3.3 EN/UVLO

EN/UVLO controls the ON and OFF state of the internal MOSFET, as an input pin. In its high state, the internal MOSFET is enabled. A low on this pin turns off the internal MOSFET. High and Low levels are specified in the parametric table of the datasheet.

A voltage $V_{EN/UVLO} < V_{ENF}$ on this pin turns off the internal FET, thus disconnecting V_{IN} from V_{OUT} , while voltage below V_{SHUTF} takes the device into shutdown mode, with I_Q less than 1 μA to ensure minimal power loss.

The EN/UVLO pin can be directly driven by a 1.8 V, 3.3 V or 5 V general purpose output pin.

The internal de-glitch delay on EN/UVLO falling edge is intentionally kept low (2.5 μs typical) for quick detection of power failure. For applications where a higher de-glitch delay on EN/UVLO is desired, or when the supply is particularly noisy, it is recommended to use an external bypass capacitor from EN/UVLO to GND.

The undervoltage lock out (UVLO) threshold can be programmed by using an external resistor divider from supply V_{IN} terminal to EN/UVLO terminal to GND shown in Figure 18. When an undervoltage or input power fail event is detected, the internal FET is quickly turned off. If the programmable UVLO function is not needed, the EN/UVLO terminal must be connected to the V_{IN} terminal. EN/UVLO terminal must not be left floating.

The device also implements internal UVLO circuitry on the V_{IN} terminal. The device disables when the V_{IN} terminal voltage falls below internal UVLO Threshold (V_{UVF}). The internal UVLO threshold has a hysteresis ($V_{UVRhyst}$). See Figure 19 and Figure 20.

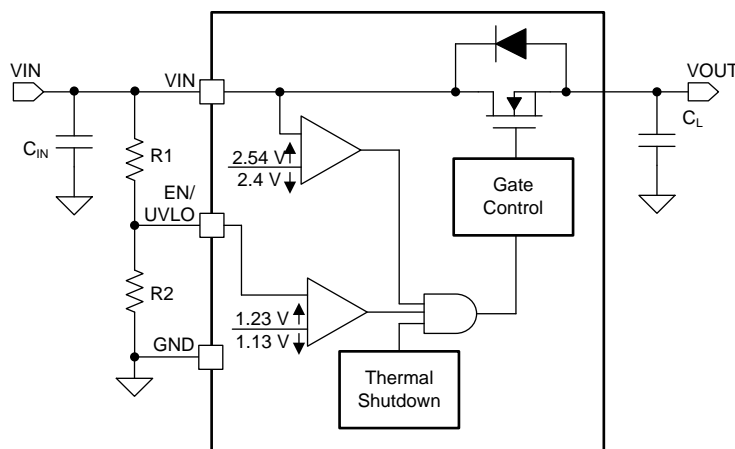

Figure 18. Configuring UVLO with External Resistor Network

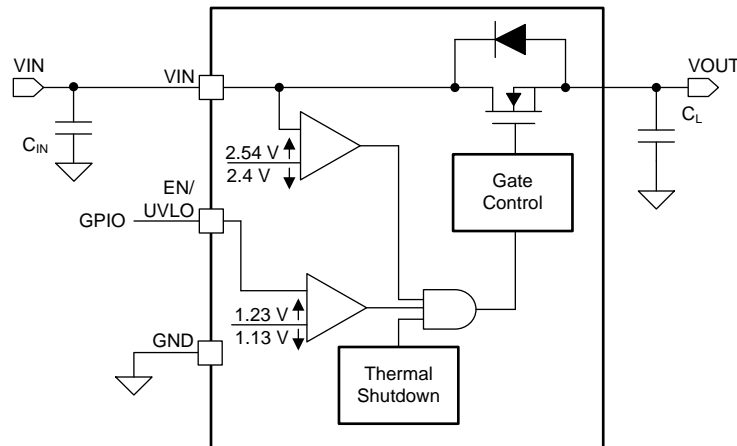

Figure 19. Using 1.8 V/3.3 V GPIO Signal Directly from Processor

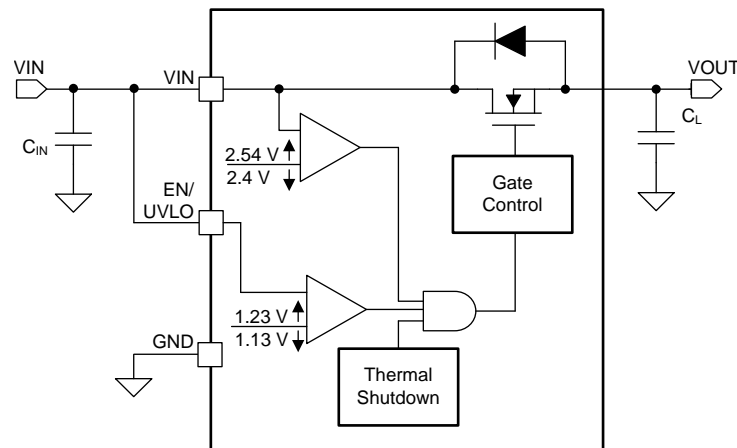

Figure 20. Default UVLO Threshold V_{UVR} Using No Additional External Components

8.3.4 Adjustable Rise Time (CT)

A capacitor to GND on the CT pin sets the slew rate. The voltage on the CT pin can be as high as 2.5 V. An approximate formula for the relationship between CT and slew rate is shown in Equation 3. This equation accounts for 10% to 90% measurement on VOUT and does NOT apply for $CT < 1$ nF.

Use Table 2 to determine rise times for when $CT \geq 1$ nF.

$$SR = 46.62 / CT$$

where

- SR is the slew rate (in V/μs)
 - CT is the the capacitance value on the CT pin (in pF)
- (3)

Rise time can be calculated by dividing the input voltage by the slew rate. Table 2 describes rise time values measured on a typical device. Rise times shown below are only valid for the power-up sequence where VIN is already in steady state condition before the EN/UVLO pin is asserted high.

Table 2. Rise Time Table

CT (pF)	RISE TIME (μ s) 10% - 90%, $C_L = 0.1 \mu$ F, $C_{IN} = 1 \mu$ F, $R_L = 10 \Omega$				
	VIN = 18 V	VIN = 12 V	VIN = 9 V	VIN = 5 V	VIN = 3.3 V
0	115	91	78	60	98
470	136	94	80	63	98
1000	310	209	158	91	102
2200	688	464	345	198	135
4700	1430	957	704	397	265
10000	3115	2085	1540	864	550
27000	8230	5460	4010	2245	1430

8.3.5 Thermal Shutdown

The switch disables when the junction temperature (T_J) rises above the thermal shutdown threshold, T_{SD} . The switch re-enables once the temperature drops below the $T_{SD} - T_{SD,HYS}$ value.

8.4 Device Functional Modes

The features of the TPS22810-Q1 depend on the operating mode. [Table 3](#) summarizes the Device Functional Modes.

Table 3. Function Table

EN/UVLO	Device State
L	Disabled
H	Enabled

9 Application and Implementation

NOTE

Information in the following applications sections is not part of the TI component specification, and TI does not warrant its accuracy or completeness. TI's customers are responsible for determining suitability of components for their purposes. Customers should validate and test their design implementation to confirm system functionality.

9.1 Application Information

This section highlights some of the design considerations when implementing this device in various applications. A PSPICE model for this device is also available in the product page of this device on www.ti.com (See the Device Support section for more information).

9.1.1 ON and OFF Control

The EN/UVLO pin controls the state of the switch. Asserting EN/UVLO high enables the switch. EN/UVLO is active high and has a low threshold that can interface with low-voltage signals. The EN/UVLO pin is compatible with standard GPIO logic thresholds. It can be used with any microcontroller with 1.2 V or higher GPIO voltage. This pin cannot be left floating and must be driven either high or low for proper functionality.

9.1.2 Input Capacitor (Optional)

To limit the voltage drop on the input supply caused by transient inrush currents when the switch turns on into a discharged load capacitor, a capacitor must be placed between VIN and GND. A 1- μ F ceramic capacitor, C_{IN} , placed close to the pins, is usually sufficient. Higher values of C_{IN} can be used to further reduce the voltage drop during high current applications. When switching heavy loads, it is recommended to have an input capacitor about 10 times higher than the output capacitor to avoid excessive voltage drop.

9.1.3 Output Capacitor (Optional)

Due to the integrated body diode in the NMOS switch, a C_{IN} greater than C_L is highly recommended. A C_L greater than C_{IN} can cause VOUT to exceed VIN when the system supply is removed. This can result in current flow through the body diode from VOUT to VIN. A C_{IN} to C_L ratio of 10 to 1 is recommended for minimizing VIN dip caused by inrush currents during startup; however, a 10 to 1 ratio for capacitance is not required for proper functionality of the device. A ratio smaller than 10 to 1 (such as 1 to 1) can cause slightly more VIN dip upon turnon due to inrush currents.

This can be mitigated by increasing the capacitance on the CT pin for a longer rise time.

9.2 Typical Application

This typical application demonstrates how the TPS22810-Q1 can be used to power downstream modules.

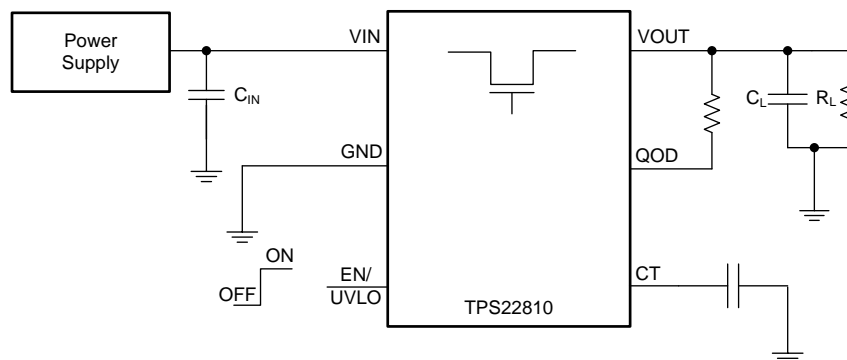

Figure 21. Typical Application Schematic

Typical Application (continued)

9.2.1 Design Requirements

For this design example, use the values listed in [Table 4](#):

Table 4. Design Parameters

DESIGN PARAMETER	EXAMPLE VALUE
V_{IN}	12 V
Load current	2 A
C_L	22 μ F
Desired fall time	20 ms
Maximum acceptable inrush current	400 mA

9.2.2 Detailed Design Procedure

9.2.2.1 Shutdown Sequencing During Unexpected Power Loss

Using the adjustable Quick Output Discharge function of the TPS22810-Q1, adding a load switch to each power rail can be used to manage the power down sequencing in the event of an unexpected power loss (for example, battery removal). To determine the QOD values for each load switch, first confirm the power down order of the device you wish to power sequence. Be sure to check if there are voltage or timing margins that must be maintained during power down. Next, consult [Table 1](#) to determine appropriate C_L and R_{QOD} values for each power rail's load switch so that the load switches' fall times correspond to the order in which they need to be powered down. In the above example, we must have this power rail's fall time to be 4 ms. Using [Equation 2](#), we can determine the appropriate R_{QOD} to achieve our desired fall time.

Since fall times are measured from 90% of V_{OUT} to 10% of V_{OUT} , using [Equation 2](#), we get [Equation 4](#) and [Equation 5](#).

$$1.2V = 10.8V \times e^{-(20ms)/(R_{QOD} \times (22\mu F))} \quad (4)$$

$$R_{QOD} = 413.7 \Omega \quad (5)$$

Consulting [Figure 6](#), R_{PD} at $V_{IN} = 12$ V is approximately 250 Ω . Using [Equation 1](#), the required external QOD resistance can be calculated shown in [Equation 6](#) and [Equation 7](#).

$$413.7 \Omega = 250 \Omega + R_{EXT} \quad (6)$$

$$R_{EXT} = 163.7 \Omega \quad (7)$$

[Figure 22](#) through [Figure 25](#) are scope shots demonstrating an example of the QOD functionality when power is removed from the device (both ON and V_{IN} are disconnected simultaneously). In the scope shots, the $V_{IN} = 12$ V and correspond to when $R_{QOD} = 1000 \Omega$, $R_{QOD} = 500 \Omega$, and QOD = VOUT with two values of $C_L = 10 \mu$ F and 22 μ F.

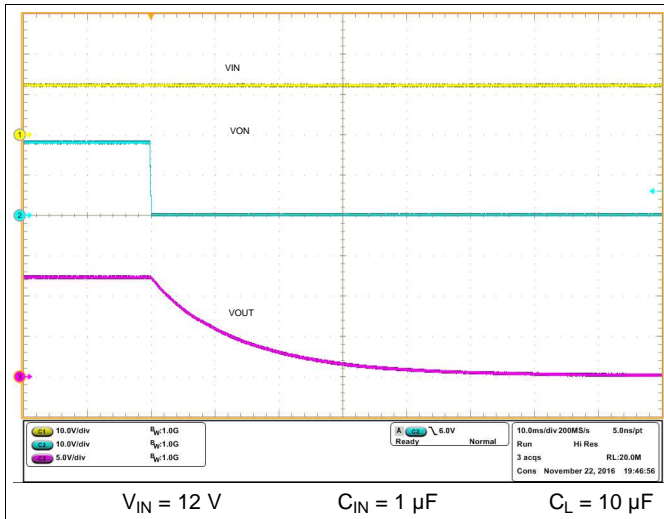

Figure 22. Fall Time t_F at $V_{IN} = 12\text{ V}$, $R_{QOD} = 1000\ \Omega$

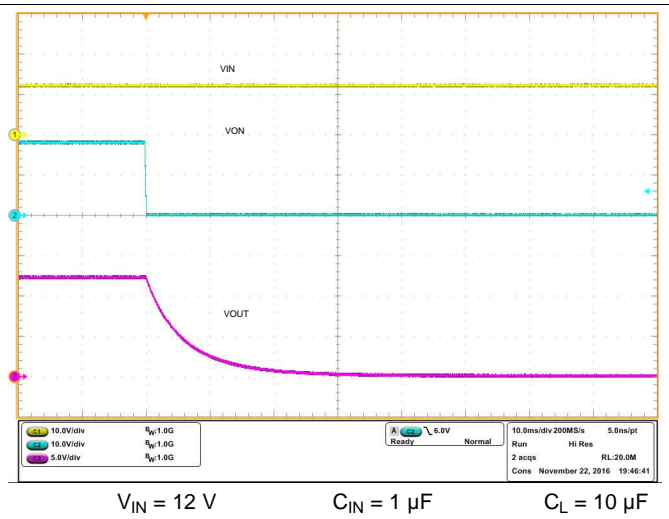

Figure 23. Fall Time t_F at $V_{IN} = 12\text{ V}$, $R_{QOD} = 500\ \Omega$

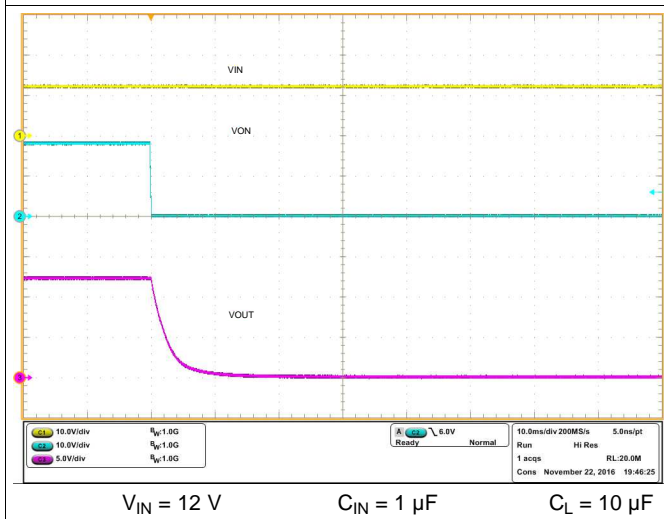

Figure 24. t_F at $V_{IN} = 12\text{ V}$, $QOD = V_{OUT}$

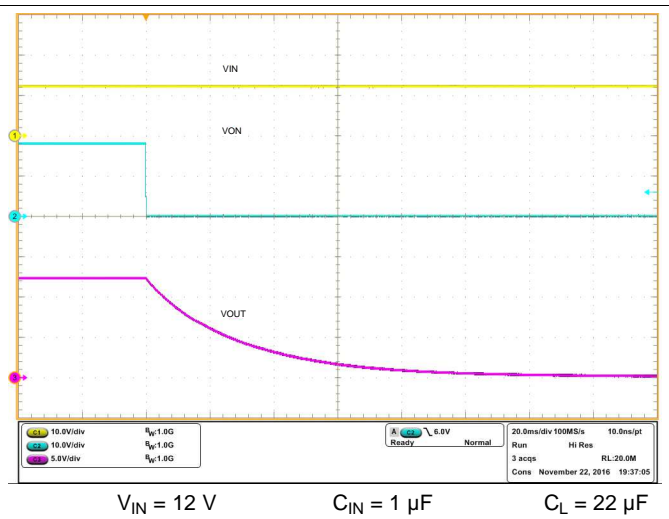
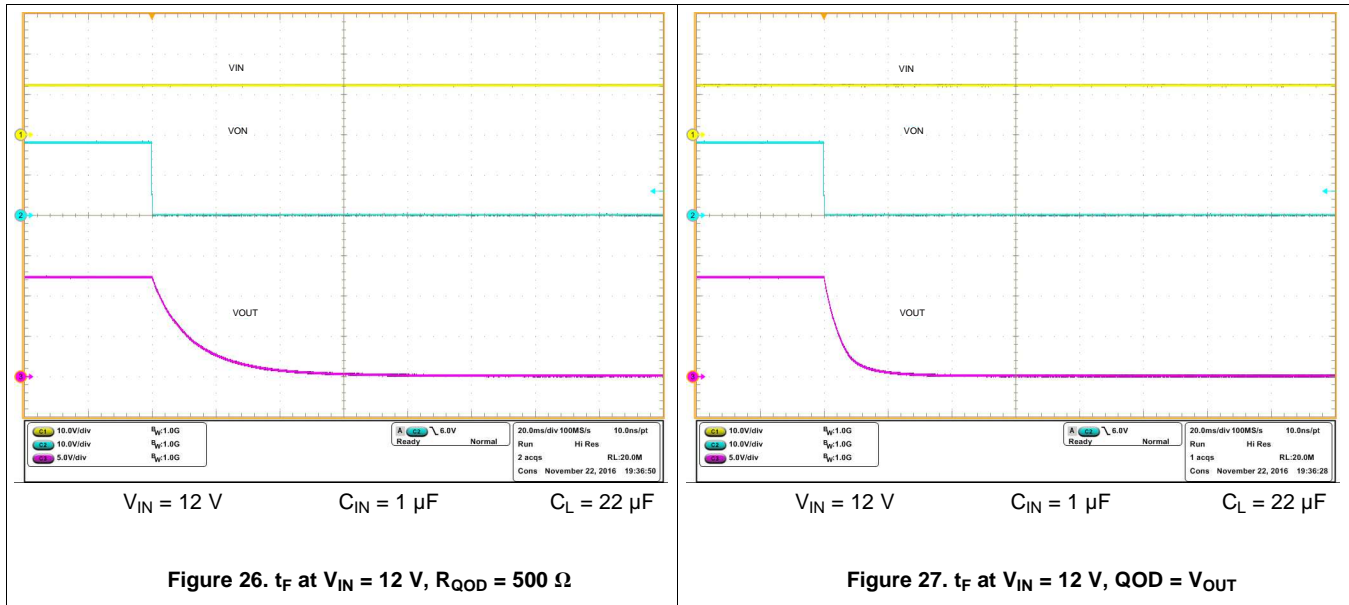

Figure 25. t_F at $V_{IN} = 12\text{ V}$, $R_{QOD} = 1000\ \Omega$



9.2.2.2 VIN to VOUT Voltage Drop

The VIN to VOUT voltage drop in the device is determined by the R_{ON} of the device and the load current. The R_{ON} of the device depends upon the VIN conditions of the device. Refer to the R_{ON} specification of the device in the *Electrical Characteristics* table of this datasheet. Once the R_{ON} of the device is determined based upon the VIN conditions, use Equation 8 to calculate the VIN to VOUT voltage drop.

$$\Delta V = I_{LOAD} \times R_{ON}$$

where

- ΔV is the voltage drop from VIN to VOUT
 - I_{LOAD} is the load current
 - R_{ON} is the On-resistance of the device for a specific V_{IN}
- (8)

An appropriate I_{LOAD} must be chosen such that the I_{MAX} specification of the device is not violated.

9.2.2.3 Inrush Current

To determine how much inrush current is caused by the C_L capacitor, use Equation 9.

$$I_{INRUSH} = C_L \times \frac{dV_{OUT}}{dt}$$

where

- I_{INRUSH} is the amount of inrush caused by C_L
 - C_L is the capacitance on VOUT
 - dt is the Output Voltage rise time during the ramp up of VOUT when the device is enabled
 - dV_{OUT} is the change in V_{OUT} during the ramp up of VOUT when the device is enabled
- (9)

The appropriate rise time can be calculated using the design requirements and the inrush current equation. When we calculate the rise time (measured from 10% to 90% of V_{OUT}), we account for this in our dV_{OUT} parameter (80% of $V_{OUT} = 9.6\text{ V}$) shown in Equation 10 and Equation 11.

$$400\text{ mA} = 22\ \mu\text{F} \times 9.6\text{ V}/dt \tag{10}$$

$$dt = 528\ \mu\text{s} \tag{11}$$

To ensure an inrush current of less than 400 mA, choose a CT value that yields a rise time of more than 528 μs . Consulting Table 2 at $V_{IN} = 12\text{ V}$, $CT = 4700\text{ pF}$ provides a typical rise time of 957 μs . Using this rise time and voltage into Equation 9, yields Equation 12 and Equation 13.

$$I_{Inrush} = 22\ \mu\text{F} \times 9.6\text{ V}/957\ \mu\text{s} \tag{12}$$

$$I_{Inrush} = 220\text{ mA} \tag{13}$$

An appropriate C_L value must be placed on VOUT such that the I_{MAX} and I_{PLS} specifications of the device are not violated.

9.2.3 Application Curves

See the oscilloscope captures below for an example of how the CT capacitor can be used to reduce inrush current for $V_{IN} = 12\text{ V}$. See the [Adjustable Rise Time \(CT\)](#) section for rise times for corresponding CT values.

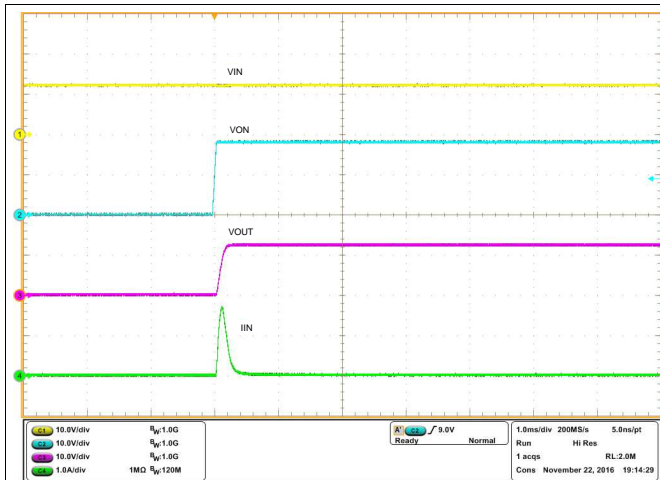

Figure 28. TPS22810-Q1 Inrush Current With $C_L = 22\ \mu\text{F}$, $CT = 0\ \text{pF}$

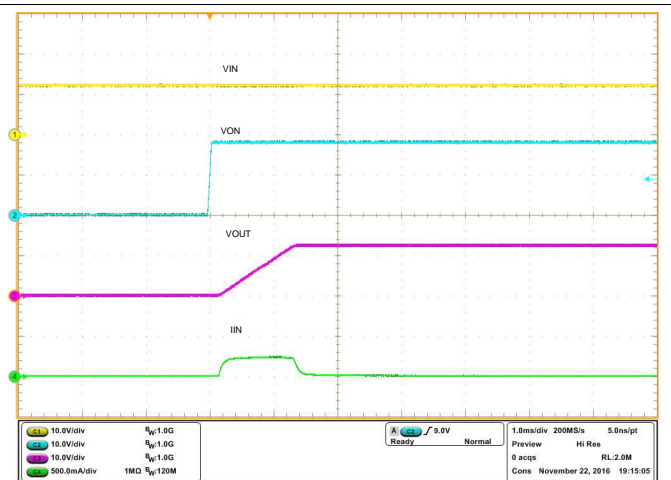

Figure 29. TPS22810-Q1 Inrush Current with $C_L = 22\ \mu\text{F}$, $CT = 4700\ \text{pF}$

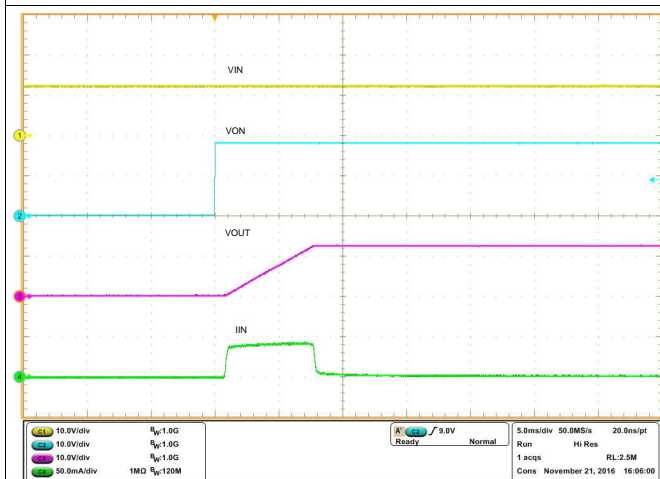

Figure 30. TPS22810-Q1 Inrush Current With $C_L = 22\ \mu\text{F}$, $CT = 27000\ \text{pF}$

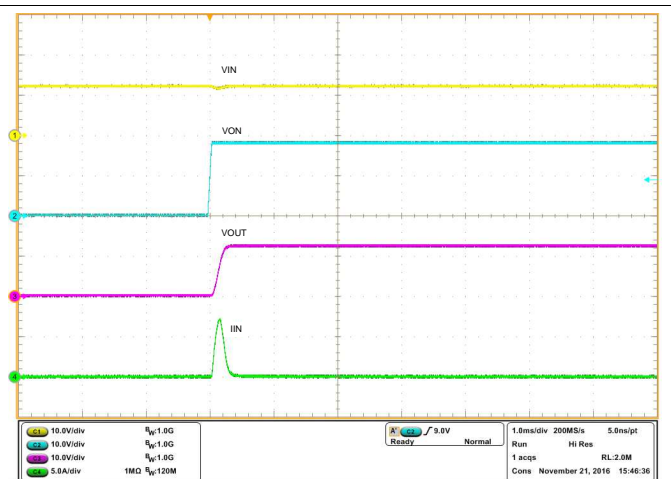

Figure 31. TPS22810-Q1 Inrush Current With $C_L = 100\ \mu\text{F}$, $CT = 0\ \text{pF}$

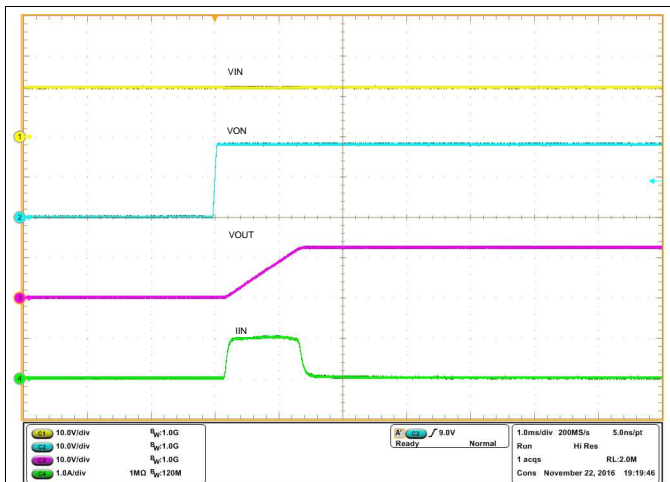

Figure 32. TPS22810-Q1 Inrush Current With $C_L = 100 \mu\text{F}$, $C_T = 4700 \text{ pF}$

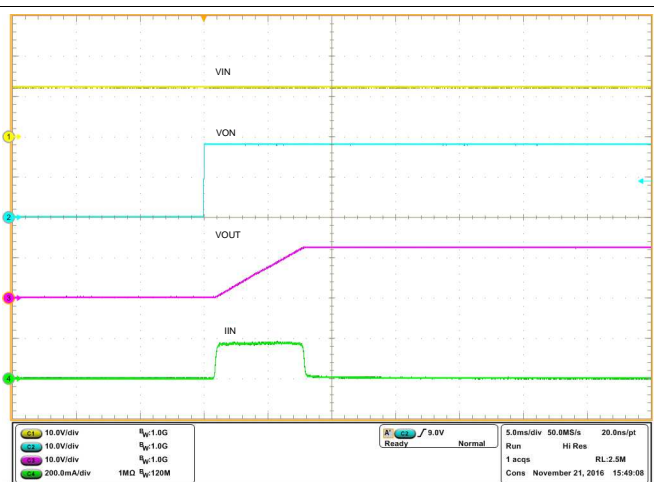

Figure 33. TPS22810-Q1 Inrush Current With $C_L = 100 \mu\text{F}$, $C_T = 27000 \text{ pF}$

10 Power Supply Recommendations

The device is designed to operate from a VIN range of 2.7 V to 18 V. This supply must be well regulated and placed as close to the device terminal as possible with the recommended 1- μF bypass capacitor. If the supply is located more than a few inches from the device terminals, additional bulk capacitance may be required in addition to the ceramic bypass capacitors. If additional bulk capacitance is required, an electrolytic, tantalum, or ceramic capacitor of 1- μF may be sufficient.

The TPS22810-Q1 operates regardless of power sequencing order. The order in which voltages are applied to VIN and EN/UVLO does not damage the device as long as the voltages do not exceed the absolute maximum operating conditions.

11 Layout

11.1 Layout Guidelines

- VIN and VOUT traces must be as short and wide as possible to accommodate for high current.
- The VIN pin must be bypassed to ground with low ESR ceramic bypass capacitors. The typical recommended bypass capacitance is 1- μ F ceramic with X5R or X7R dielectric. This capacitor must be placed as close to the device pins as possible.

11.2 Layout Example

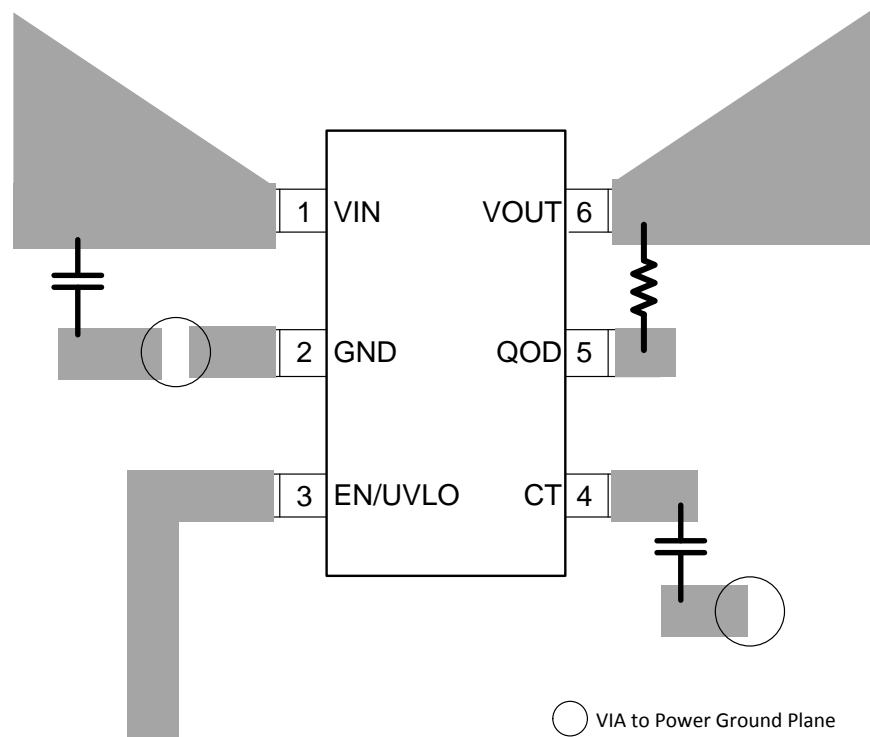

Figure 34. Recommended Board Layout

11.3 Thermal Considerations

For best performance, all traces must be as short as possible. To be most effective, the input and output capacitors must be placed close to the device to minimize the effects that parasitic trace inductances may have on normal and short-circuit operation. Using wide traces for VIN, VOUT, and GND helps minimize the parasitic electrical effects along with minimizing the case to ambient thermal impedance.

The maximum IC junction temperature must be restricted to 150°C under normal operating conditions. To calculate the maximum allowable dissipation, $P_{D(max)}$ for a given output current and ambient temperature, use [Equation 14](#).

$$P_{D(MAX)} = \frac{T_{J(MAX)} - T_A}{\theta_{JA}}$$

where

- $P_{D(MAX)}$ is the maximum allowable power dissipation
- $T_{J(MAX)}$ is the maximum allowable junction temperature (150°C for the TPS22810-Q1)
- T_A is the ambient temperature of the device
- θ_{JA} is the junction to air thermal impedance. Refer to the [Thermal Information](#) table. This parameter highly depends on the board layout. (14)

12 Device and Documentation Support

12.1 Device Support

12.1.1 Developmental Support

For the TPS22810 PSpice Transient Model, see [TPS22810 PSpice Transient Model](#)

12.2 Documentation Support

12.2.1 Related Documentation

For related documentation see the following:

- [TPS22810 Load Switch Evaluation Module](#)
- [Selecting a Load Switch to Replace a Discrete Solution](#)
- [Timing of Load Switches](#)

12.3 Receiving Notification of Documentation Updates

To receive notification of documentation updates—including silicon errata—go to the product folder for your device on ti.com. In the upper right corner, click the *Alert me* button. This registers you to receive a weekly digest of product information that has changed (if any). For change details, check the revision history of any revised document.

12.4 Community Resources

The following links connect to TI community resources. Linked contents are provided "AS IS" by the respective contributors. They do not constitute TI specifications and do not necessarily reflect TI's views; see TI's [Terms of Use](#).

TI E2E™ Online Community *TI's Engineer-to-Engineer (E2E) Community*. Created to foster collaboration among engineers. At e2e.ti.com, you can ask questions, share knowledge, explore ideas and help solve problems with fellow engineers.

Design Support *TI's Design Support* Quickly find helpful E2E forums along with design support tools and contact information for technical support.

12.5 Trademarks

E2E is a trademark of Texas Instruments.

All other trademarks are the property of their respective owners.

12.6 Electrostatic Discharge Caution



This integrated circuit can be damaged by ESD. Texas Instruments recommends that all integrated circuits be handled with appropriate precautions. Failure to observe proper handling and installation procedures can cause damage.

ESD damage can range from subtle performance degradation to complete device failure. Precision integrated circuits may be more susceptible to damage because very small parametric changes could cause the device not to meet its published specifications.

12.7 Glossary

[SLYZ022](#) — *TI Glossary*.

This glossary lists and explains terms, acronyms, and definitions.

13 Mechanical, Packaging, and Orderable Information

The following pages include mechanical, packaging, and orderable information. This information is the most current data available for the designated devices. This data is subject to change without notice and revision of this document. For browser-based versions of this data sheet, refer to the left-hand navigation.

PACKAGING INFORMATION

Orderable Device	Status (1)	Package Type	Package Drawing	Pins	Package Qty	Eco Plan (2)	Lead/Ball Finish (6)	MSL Peak Temp (3)	Op Temp (°C)	Device Marking (4/5)	Samples
TPS22810TDBVRQ1	ACTIVE	SOT-23	DBV	6	3000	Green (RoHS & no Sb/Br)	CU NIPDAU	Level-2-260C-1 YEAR	-40 to 105	1EFF	Samples

(1) The marketing status values are defined as follows:

ACTIVE: Product device recommended for new designs.

LIFEBUY: TI has announced that the device will be discontinued, and a lifetime-buy period is in effect.

NRND: Not recommended for new designs. Device is in production to support existing customers, but TI does not recommend using this part in a new design.

PREVIEW: Device has been announced but is not in production. Samples may or may not be available.

OBSOLETE: TI has discontinued the production of the device.

(2) **RoHS:** TI defines "RoHS" to mean semiconductor products that are compliant with the current EU RoHS requirements for all 10 RoHS substances, including the requirement that RoHS substance do not exceed 0.1% by weight in homogeneous materials. Where designed to be soldered at high temperatures, "RoHS" products are suitable for use in specified lead-free processes. TI may reference these types of products as "Pb-Free".

RoHS Exempt: TI defines "RoHS Exempt" to mean products that contain lead but are compliant with EU RoHS pursuant to a specific EU RoHS exemption.

Green: TI defines "Green" to mean the content of Chlorine (Cl) and Bromine (Br) based flame retardants meet JS709B low halogen requirements of <=1000ppm threshold. Antimony trioxide based flame retardants must also meet the <=1000ppm threshold requirement.

(3) MSL, Peak Temp. - The Moisture Sensitivity Level rating according to the JEDEC industry standard classifications, and peak solder temperature.

(4) There may be additional marking, which relates to the logo, the lot trace code information, or the environmental category on the device.

(5) Multiple Device Markings will be inside parentheses. Only one Device Marking contained in parentheses and separated by a "~" will appear on a device. If a line is indented then it is a continuation of the previous line and the two combined represent the entire Device Marking for that device.

(6) Lead/Ball Finish - Orderable Devices may have multiple material finish options. Finish options are separated by a vertical ruled line. Lead/Ball Finish values may wrap to two lines if the finish value exceeds the maximum column width.

Important Information and Disclaimer:The information provided on this page represents TI's knowledge and belief as of the date that it is provided. TI bases its knowledge and belief on information provided by third parties, and makes no representation or warranty as to the accuracy of such information. Efforts are underway to better integrate information from third parties. TI has taken and continues to take reasonable steps to provide representative and accurate information but may not have conducted destructive testing or chemical analysis on incoming materials and chemicals. TI and TI suppliers consider certain information to be proprietary, and thus CAS numbers and other limited information may not be available for release.

In no event shall TI's liability arising out of such information exceed the total purchase price of the TI part(s) at issue in this document sold by TI to Customer on an annual basis.

OTHER QUALIFIED VERSIONS OF TPS22810-Q1 :

- Catalog: [TPS22810](#)

NOTE: Qualified Version Definitions:

- Catalog - TI's standard catalog product

MECHANICAL DATA

DBV (R-PDSO-G6)

PLASTIC SMALL-OUTLINE PACKAGE

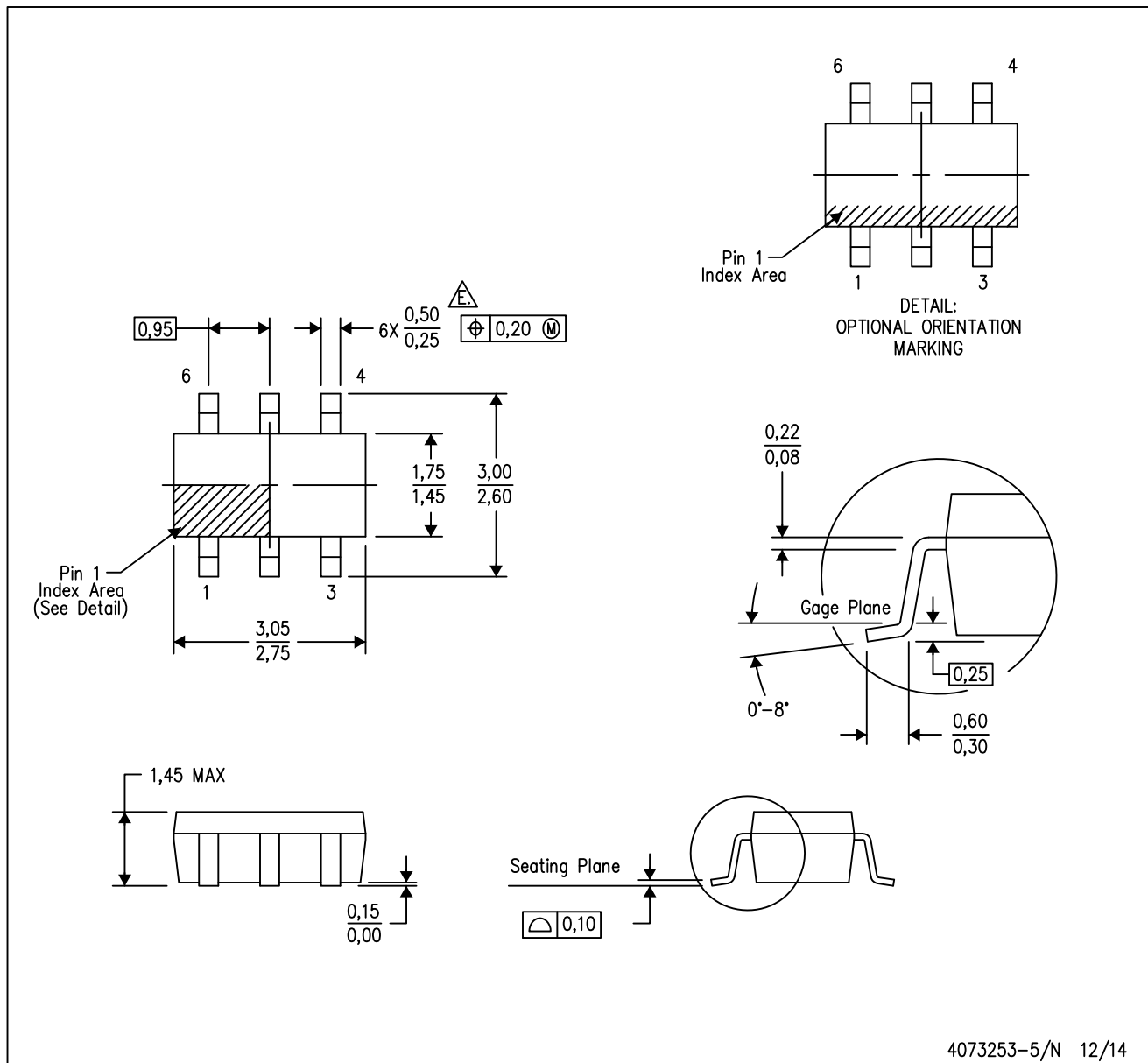

- NOTES:
- A. All linear dimensions are in millimeters.
 - B. This drawing is subject to change without notice.
 - C. Body dimensions do not include mold flash or protrusion. Mold flash and protrusion shall not exceed 0.15 per side.
 - D. Leads 1,2,3 may be wider than leads 4,5,6 for package orientation.
- Falls within JEDEC MO-178 Variation AB, except minimum lead width.

DBV (R-PDSO-G6)

PLASTIC SMALL OUTLINE



- NOTES:
- A. All linear dimensions are in millimeters.
 - B. This drawing is subject to change without notice.
 - C. Customers should place a note on the circuit board fabrication drawing not to alter the center solder mask defined pad.
 - D. Publication IPC-7351 is recommended for alternate designs.
 - E. Laser cutting apertures with trapezoidal walls and also rounding corners will offer better paste release. Customers should contact their board assembly site for stencil design recommendations. Example stencil design based on a 50% volumetric metal load solder paste. Refer to IPC-7525 for other stencil recommendations.

IMPORTANT NOTICE

Texas Instruments Incorporated (TI) reserves the right to make corrections, enhancements, improvements and other changes to its semiconductor products and services per JESD46, latest issue, and to discontinue any product or service per JESD48, latest issue. Buyers should obtain the latest relevant information before placing orders and should verify that such information is current and complete.

TI's published terms of sale for semiconductor products (<http://www.ti.com/sc/docs/stdterms.htm>) apply to the sale of packaged integrated circuit products that TI has qualified and released to market. Additional terms may apply to the use or sale of other types of TI products and services.

Reproduction of significant portions of TI information in TI data sheets is permissible only if reproduction is without alteration and is accompanied by all associated warranties, conditions, limitations, and notices. TI is not responsible or liable for such reproduced documentation. Information of third parties may be subject to additional restrictions. Resale of TI products or services with statements different from or beyond the parameters stated by TI for that product or service voids all express and any implied warranties for the associated TI product or service and is an unfair and deceptive business practice. TI is not responsible or liable for any such statements.

Buyers and others who are developing systems that incorporate TI products (collectively, "Designers") understand and agree that Designers remain responsible for using their independent analysis, evaluation and judgment in designing their applications and that Designers have full and exclusive responsibility to assure the safety of Designers' applications and compliance of their applications (and of all TI products used in or for Designers' applications) with all applicable regulations, laws and other applicable requirements. Designer represents that, with respect to their applications, Designer has all the necessary expertise to create and implement safeguards that (1) anticipate dangerous consequences of failures, (2) monitor failures and their consequences, and (3) lessen the likelihood of failures that might cause harm and take appropriate actions. Designer agrees that prior to using or distributing any applications that include TI products, Designer will thoroughly test such applications and the functionality of such TI products as used in such applications.

TI's provision of technical, application or other design advice, quality characterization, reliability data or other services or information, including, but not limited to, reference designs and materials relating to evaluation modules, (collectively, "TI Resources") are intended to assist designers who are developing applications that incorporate TI products; by downloading, accessing or using TI Resources in any way, Designer (individually or, if Designer is acting on behalf of a company, Designer's company) agrees to use any particular TI Resource solely for this purpose and subject to the terms of this Notice.

TI's provision of TI Resources does not expand or otherwise alter TI's applicable published warranties or warranty disclaimers for TI products, and no additional obligations or liabilities arise from TI providing such TI Resources. TI reserves the right to make corrections, enhancements, improvements and other changes to its TI Resources. TI has not conducted any testing other than that specifically described in the published documentation for a particular TI Resource.

Designer is authorized to use, copy and modify any individual TI Resource only in connection with the development of applications that include the TI product(s) identified in such TI Resource. NO OTHER LICENSE, EXPRESS OR IMPLIED, BY ESTOPPEL OR OTHERWISE TO ANY OTHER TI INTELLECTUAL PROPERTY RIGHT, AND NO LICENSE TO ANY TECHNOLOGY OR INTELLECTUAL PROPERTY RIGHT OF TI OR ANY THIRD PARTY IS GRANTED HEREIN, including but not limited to any patent right, copyright, mask work right, or other intellectual property right relating to any combination, machine, or process in which TI products or services are used. Information regarding or referencing third-party products or services does not constitute a license to use such products or services, or a warranty or endorsement thereof. Use of TI Resources may require a license from a third party under the patents or other intellectual property of the third party, or a license from TI under the patents or other intellectual property of TI.

TI RESOURCES ARE PROVIDED "AS IS" AND WITH ALL FAULTS. TI DISCLAIMS ALL OTHER WARRANTIES OR REPRESENTATIONS, EXPRESS OR IMPLIED, REGARDING RESOURCES OR USE THEREOF, INCLUDING BUT NOT LIMITED TO ACCURACY OR COMPLETENESS, TITLE, ANY EPIDEMIC FAILURE WARRANTY AND ANY IMPLIED WARRANTIES OF MERCHANTABILITY, FITNESS FOR A PARTICULAR PURPOSE, AND NON-INFRINGEMENT OF ANY THIRD PARTY INTELLECTUAL PROPERTY RIGHTS. TI SHALL NOT BE LIABLE FOR AND SHALL NOT DEFEND OR INDEMNIFY DESIGNER AGAINST ANY CLAIM, INCLUDING BUT NOT LIMITED TO ANY INFRINGEMENT CLAIM THAT RELATES TO OR IS BASED ON ANY COMBINATION OF PRODUCTS EVEN IF DESCRIBED IN TI RESOURCES OR OTHERWISE. IN NO EVENT SHALL TI BE LIABLE FOR ANY ACTUAL, DIRECT, SPECIAL, COLLATERAL, INDIRECT, PUNITIVE, INCIDENTAL, CONSEQUENTIAL OR EXEMPLARY DAMAGES IN CONNECTION WITH OR ARISING OUT OF TI RESOURCES OR USE THEREOF, AND REGARDLESS OF WHETHER TI HAS BEEN ADVISED OF THE POSSIBILITY OF SUCH DAMAGES.

Unless TI has explicitly designated an individual product as meeting the requirements of a particular industry standard (e.g., ISO/TS 16949 and ISO 26262), TI is not responsible for any failure to meet such industry standard requirements.

Where TI specifically promotes products as facilitating functional safety or as compliant with industry functional safety standards, such products are intended to help enable customers to design and create their own applications that meet applicable functional safety standards and requirements. Using products in an application does not by itself establish any safety features in the application. Designers must ensure compliance with safety-related requirements and standards applicable to their applications. Designer may not use any TI products in life-critical medical equipment unless authorized officers of the parties have executed a special contract specifically governing such use. Life-critical medical equipment is medical equipment where failure of such equipment would cause serious bodily injury or death (e.g., life support, pacemakers, defibrillators, heart pumps, neurostimulators, and implantables). Such equipment includes, without limitation, all medical devices identified by the U.S. Food and Drug Administration as Class III devices and equivalent classifications outside the U.S.

TI may expressly designate certain products as completing a particular qualification (e.g., Q100, Military Grade, or Enhanced Product). Designers agree that it has the necessary expertise to select the product with the appropriate qualification designation for their applications and that proper product selection is at Designers' own risk. Designers are solely responsible for compliance with all legal and regulatory requirements in connection with such selection.

Designer will fully indemnify TI and its representatives against any damages, costs, losses, and/or liabilities arising out of Designer's non-compliance with the terms and provisions of this Notice.