

## AUTOSWITCHING POWER MUX

### FEATURES

- Two-Input, One-Output Power Multiplexer With Low  $r_{DS(on)}$  Switches:
  - 84 m $\Omega$  Typ (TPS2111)
  - 120 m $\Omega$  Typ (TPS2110)
- Reverse and Cross-Conduction Blocking
- Wide Operating Voltage Range . . . . 2.8 V to 5.5 V
- Low Standby Current . . . . 0.5- $\mu$ A Typ
- Low Operating Current . . . . 55- $\mu$ A Typ
- Adjustable Current Limit
- Controlled Output Voltage Transition Times, Limits Inrush Current and Minimizes Output Voltage Hold-Up Capacitance
- CMOS and TTL Compatible Control Inputs
- Manual and Auto-Switching Operating Modes
- Thermal Shutdown
- Available in a TSSOP-8 Package

### APPLICATIONS

- PCs
- PDAs
- Digital Cameras
- Modems
- Cell phones
- Digital Radios
- MP3 Players

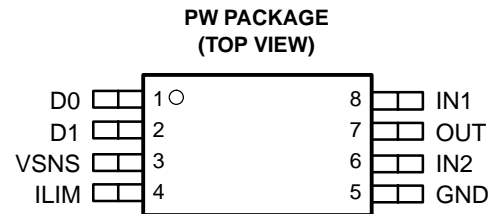

### DESCRIPTION

The TPS211x family of power multiplexers enables seamless transition between two power supplies, such as a battery and a wall adapter, each operating at 2.8–5.5 V and delivering up to 1 A. The TPS211x family includes extensive protection circuitry, including user-programmable current limiting, thermal protection, inrush current control, seamless supply transition, cross-conduction blocking, and reverse-conduction blocking. These features greatly simplify designing power multiplexer applications.

### TYPICAL APPLICATION

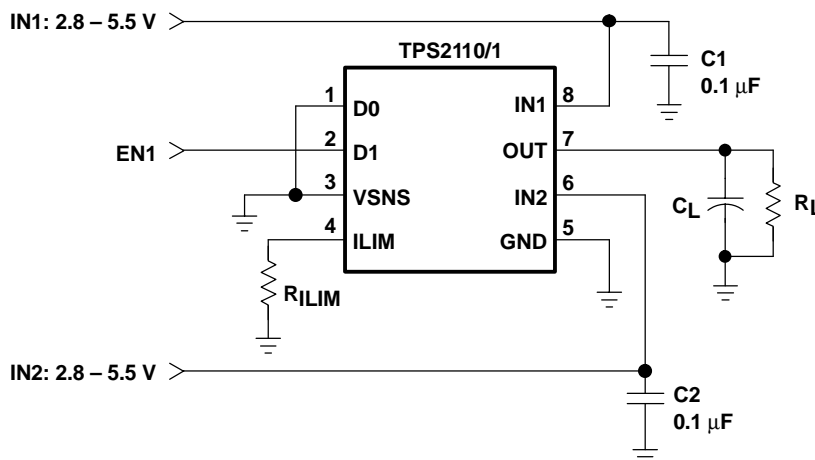

Please be aware that an important notice concerning availability, standard warranty, and use in critical applications of Texas Instruments semiconductor products and disclaimers thereto appears at the end of this data sheet.



These devices have limited built-in ESD protection. The leads should be shorted together or the device placed in conductive foam during storage or handling to prevent electrostatic damage to the MOS gates.

### AVAILABLE OPTIONS

FEATURE		TPS2110	TPS2111	TPS2112	TPS2113	TPS2114	TPS2115
Current Limit Adjustment Range		0.31–0.75A	0.63–1.25A	0.31–0.75A	0.63–1.25A	0.31–0.75A	0.63–1.25A
Switching modes	Manual	Yes	Yes	No	No	Yes	Yes
	Automatic	Yes	Yes	Yes	Yes	Yes	Yes
Switch Status Output		No	No	Yes	Yes	Yes	Yes
Package		TSSOP-8	TSSOP-8	TSSOP-8	TSSOP-8	TSSOP-8	TSSOP-8

### ORDERING INFORMATION

T <sub>A</sub>	PACKAGE	ORDERING NUMBER(1)	MARKINGS
–40°C to 85°C	TSSOP-8 (PW)	TPS2110PW	2110
		TPS2111PW	2111

(1) The PW package is available taped and reeled. Add an R suffix to the device type (e.g., TPS2110PWR) to indicate tape and reel.

### PACKAGE DISSIPATION RATINGS

PACKAGE	DERATING FACTOR ABOVE T <sub>A</sub> = 25°C	T <sub>A</sub> ≤ 25°C POWER RATING	T <sub>A</sub> = 70°C POWER RATING	T <sub>A</sub> = 85°C POWER RATING
TSSOP-8 (PW)	3.87 mW/°C	386.84 mW	212.76 mW	154.73 mW

### ABSOLUTE MAXIMUM RATINGS

over operating free-air temperature range unless otherwise noted(1)

		TPS2110, TPS2111
Input voltage range at pins IN1, IN2, D0, D1, VSNS, ILIM(2)		–0.3 V to 6 V
Output voltage range, V <sub>O(OUT)</sub> (2)		–0.3 V to 6 V
Continuous output current, I <sub>O</sub>	TPS2110	0.9 A
	TPS2111	1.5 A
Continuous total power dissipation		See Dissipation Rating Table
Operating virtual junction temperature range, T <sub>J</sub>		–40°C to 125°C
Storage temperature range, T <sub>stg</sub>		–65°C to 150°C
Lead temperature soldering 1,6 mm (1/16 inch) from case for 10 seconds		260°C

(1) Stresses beyond those listed under “absolute maximum ratings” may cause permanent damage to the device. These are stress ratings only, and functional operation of the device at these or any other conditions beyond those indicated under “recommended operating conditions” is not implied. Exposure to absolute-maximum-rated conditions for extended periods may affect device reliability.

(2) All voltages are with respect to GND.

### RECOMMENDED OPERATING CONDITIONS

		MIN	MAX	UNIT
Input voltage at IN1, V <sub>I(IN1)</sub>	V <sub>I(IN2)</sub> ≥ 2.8 V	1.5	5.5	V
	V <sub>I(IN2)</sub> < 2.8 V	2.8	5.5	
Input voltage at IN2, V <sub>I(IN2)</sub>	V <sub>I(IN1)</sub> ≥ 2.8 V	1.5	5.5	V
	V <sub>I(IN1)</sub> < 2.8 V	2.8	5.5	
Input voltage, V <sub>I(D0)</sub> , V <sub>I(D1)</sub> , V <sub>I(VSNS)</sub>		0	5.5	V
Current limit adjustment range, I <sub>O(OUT)</sub>	TPS2110	0.31	0.75	A
	TPS2111	0.63	1.25	
Operating virtual junction temperature, T <sub>J</sub>		–40	125	°C

### ELECTROSTATIC DISCHARGE (ESD) PROTECTION

	MIN	MAX	UNIT
Human body model		2	kV
CDM		500	V

## ELECTRICAL CHARACTERISTICS

over recommended operating junction temperature range,  $V_{I(IN1)} = V_{I(IN2)} = 5.5\text{ V}$ ,  $R_{LIM} = 400\ \Omega$  (unless otherwise noted)

PARAMETER	TEST CONDITIONS	TPS2110			TPS2111			UNIT
		MIN	TYP	MAX	MIN	TYP	MAX	
<b>POWER SWITCH</b>								
$r_{DS(on)}^{(1)}$ Drain-source on-state resistance (INx–OUT)	$T_J = 25^\circ\text{C}$ , $I_L = 500\text{ mA}$	$V_{I(IN1)} = V_{I(IN2)} = 5.0\text{ V}$	120	140	84	110	m $\Omega$	
		$V_{I(IN1)} = V_{I(IN2)} = 3.3\text{ V}$	120	140	84	110		
		$V_{I(IN1)} = V_{I(IN2)} = 2.8\text{ V}$	120	140	84	110		
	$T_J = 125^\circ\text{C}$ , $I_L = 500\text{ mA}$	$V_{I(IN1)} = V_{I(IN2)} = 5.0\text{ V}$		220		150	m $\Omega$	
		$V_{I(IN1)} = V_{I(IN2)} = 3.3\text{ V}$		220		150		
		$V_{I(IN1)} = V_{I(IN2)} = 2.8\text{ V}$		220		150		

(1) The TPS211x can switch a voltage as low as 1.5 V as long as there is a minimum of 2.8 V at one of the input power pins. In this specific case, the lower supply voltage has no effect on the IN1 and IN2 switch on-resistances.

PARAMETER	TEST CONDITIONS	MIN	TYP	MAX	UNIT
<b>LOGIC INPUTS (D0 AND D1)</b>					
$V_{IH}$ High-level input voltage		2			V
$V_{IL}$ Low-level input voltage				0.7	V
Input current at D0 or D1	D0 or D1 = High, sink current			1	$\mu\text{A}$
	D0 or D1 = Low, source current	0.5	1.4	5	
<b>SUPPLY AND LEAKAGE CURRENTS</b>					
Supply current from IN1 (operating)	D1 = High, D0 = Low (IN1 active), $V_{I(IN1)} = 5.5\text{ V}$ , $V_{I(IN2)} = 3.3\text{ V}$ , $I_{O(OUT)} = 0\text{ A}$		55	90	$\mu\text{A}$
	D1 = High, D0 = Low (IN1 active), $V_{I(IN1)} = 3.3\text{ V}$ , $V_{I(IN2)} = 5.5\text{ V}$ , $I_{O(OUT)} = 0\text{ A}$		1	12	
	D0 = D1 = Low (IN2 active), $V_{I(IN1)} = 5.5\text{ V}$ , $V_{I(IN2)} = 3.3\text{ V}$ , $I_{O(OUT)} = 0\text{ A}$			75	
	D0 = D1 = Low (IN2 active), $V_{I(IN1)} = 3.3\text{ V}$ , $V_{I(IN2)} = 5.5\text{ V}$ , $I_{O(OUT)} = 0\text{ A}$			1	
Supply current from IN2 (operating)	D1 = High, D0 = Low (IN1 active), $V_{I(IN1)} = 5.5\text{ V}$ , $V_{I(IN2)} = 3.3\text{ V}$ , $I_{O(OUT)} = 0\text{ A}$			1	$\mu\text{A}$
	D1 = High, D0 = Low (IN1 active), $V_{I(IN1)} = 3.3\text{ V}$ , $V_{I(IN2)} = 5.5\text{ V}$ , $I_{O(OUT)} = 0\text{ A}$			75	
	D0 = D1 = Low (IN2 active), $V_{I(IN1)} = 5.5\text{ V}$ , $V_{I(IN2)} = 3.3\text{ V}$ , $I_{O(OUT)} = 0\text{ A}$		1	12	
	D0 = D1 = Low (IN2 active), $V_{I(IN1)} = 3.3\text{ V}$ , $V_{I(IN2)} = 5.5\text{ V}$ , $I_{O(OUT)} = 0\text{ A}$		55	90	
Quiescent current from IN1 (STANDBY)	D0 = D1 = High (inactive), $V_{I(IN1)} = 5.5\text{ V}$ , $V_{I(IN2)} = 3.3\text{ V}$ , $I_{O(OUT)} = 0\text{ A}$		0.5	2	$\mu\text{A}$
	D0 = D1 = High (inactive), $V_{I(IN1)} = 3.3\text{ V}$ , $V_{I(IN2)} = 5.5\text{ V}$ , $I_{O(OUT)} = 0\text{ A}$			1	
Quiescent current from IN2 (STANDBY)	D0 = D1 = High (inactive), $V_{I(IN1)} = 5.5\text{ V}$ , $V_{I(IN2)} = 3.3\text{ V}$ , $I_{O(OUT)} = 0\text{ A}$			1	$\mu\text{A}$
	D0 = D1 = High (inactive), $V_{I(IN1)} = 3.3\text{ V}$ , $V_{I(IN2)} = 5.5\text{ V}$ , $I_{O(OUT)} = 0\text{ A}$		0.5	2	
Forward leakage current from IN1 (measured from OUT to GND)	D0 = D1 = High (inactive), $V_{I(IN1)} = 5.5\text{ V}$ , IN2 open, $V_{O(OUT)} = 0\text{ V}$ (shorted), $T_J = 25^\circ\text{C}$		0.1	5	$\mu\text{A}$
Forward leakage current from IN2 (measured from OUT to GND)	D0 = D1 = High (inactive), $V_{I(IN2)} = 5.5\text{ V}$ , IN1 open, $V_{O(OUT)} = 0\text{ V}$ (shorted), $T_J = 25^\circ\text{C}$		0.1	5	$\mu\text{A}$
Reverse leakage current to INx (measured from INx to GND)	D0 = D1 = High (inactive), $V_{I(INx)} = 0\text{ V}$ , $V_{O(OUT)} = 5.5\text{ V}$ , $T_J = 25^\circ\text{C}$		0.3	5	$\mu\text{A}$

**ELECTRICAL CHARACTERISTICS Continued**

over recommended operating junction temperature range,  $V_{I(IN1)} = V_{I(IN2)} = 5.5\text{ V}$ ,  $R_{ILIM} = 400\ \Omega$  (unless otherwise noted)

PARAMETER		TEST CONDITIONS	MIN	TYP	MAX	UNIT
<b>CURRENT LIMIT CIRCUIT</b>						
Current limit accuracy	TPS2110	$R_{ILIM} = 400\ \Omega$	0.51	0.63	0.80	A
		$R_{ILIM} = 700\ \Omega$	0.30	0.36	0.50	
	TPS2111	$R_{ILIM} = 400\ \Omega$	0.95	1.25	1.56	
		$R_{ILIM} = 700\ \Omega$	0.47	0.71	0.99	
$t_d$	Current limit settling time <sup>(1)</sup>	Time for short-circuit output current to settle within 10% of its steady state value.	1			ms
Input current at ILIM		$V_{I(ILIM)} = 0\text{ V}$ , $I_{O(OUT)} = 0\text{ A}$	-15	0		$\mu\text{A}$

(1) Not tested in production.

PARAMETER		TEST CONDITIONS	MIN	TYP	MAX	UNIT
<b>VSNS COMPARATOR</b>						
VSNS threshold voltage		$V_{I(VSNS)} \uparrow$	0.78	0.8	0.82	V
		$V_{I(VSNS)} \downarrow$	0.735	0.755	0.775	
VSNS comparator hysteresis <sup>(1)</sup>			30	60		mV
Deglitch of VSNS comparator (both $\uparrow\downarrow$ ) <sup>(1)</sup>			90	150	220	$\mu\text{s}$
Input current		$0\text{ V} \leq V_{I(VSNS)} \leq 5.5\text{ V}$	-1	1		$\mu\text{A}$
<b>UVLO</b>						
IN1 and IN2 UVLO		Falling edge	1.15	1.25		V
		Rising edge	1.30		1.35	
IN1 and IN2 UVLO hysteresis <sup>(1)</sup>			30	57	65	mV
Internal $V_{DD}$ UVLO (the higher of IN1 and IN2)		Falling edge	2.4	2.53		V
		Rising edge	2.58		2.8	
Internal $V_{DD}$ UVLO hysteresis <sup>(1)</sup>			30	50	75	mV
UVLO deglitch for IN1, IN2 <sup>(1)</sup>		Falling edge	110			$\mu\text{s}$

(1) Not tested in production.

PARAMETER		TEST CONDITIONS	MIN	TYP	MAX	UNIT
<b>REVERSE CONDUCTION BLOCKING</b>						
$\Delta V_{O(I\_block)}$	Minimum output-to-input voltage difference to block switching	$D0 = D1 = \text{high}$ , $V_{I(INx)} = 3.3\text{ V}$ . Connect OUT to a 5 V supply through a series 1-k $\Omega$ resistor. Let $D0 = \text{low}$ . Slowly decrease the supply voltage until OUT connects to IN1.	80	100	120	mV

PARAMETER		TEST CONDITIONS	MIN	TYP	MAX	UNIT
<b>THERMAL SHUTDOWN</b>						
Thermal shutdown threshold <sup>(1)</sup>		TPS211x is in current limit.	135			$^{\circ}\text{C}$
Recovery from thermal shutdown <sup>(1)</sup>		TPS211x is in current limit.	125			
Hysteresis <sup>(1)</sup>			10			
<b>IN2-IN1 COMPARATORS</b>						
Hysteresis of IN2-IN1 comparator			0.1	0.2		V
Deglitch of IN2-IN1 comparator, (both $\uparrow\downarrow$ ) <sup>(1)</sup>			90	150	220	$\mu\text{s}$

(1) Not tested in production.

**SWITCHING CHARACTERISTICS**

 over recommended operating junction temperature range,  $V_I(IN1) = V_I(IN2) = 5.5\text{ V}$ ,  $R_{LIM} = 400\ \Omega$  (unless otherwise noted)

PARAMETER	TEST CONDITIONS	TPS2110			TPS2111			UNIT		
		MIN	TYP	MAX	MIN	TYP	MAX			
<b>POWER SWITCH</b>										
$t_r$	Output rise time from an enable <sup>(1)</sup>	$V_I(IN1) = V_I(IN2) = 5\text{ V}$	$T_J = 25^\circ\text{C}$ , $C_L = 1\ \mu\text{F}$ , $I_L = 500\text{ mA}$ , See Figure 1(a)	0.5	1.0	1.5	1	1.8	3	ms
$t_f$	Output fall time from a disable <sup>(1)</sup>	$V_I(IN1) = V_I(IN2) = 5\text{ V}$	$T_J = 25^\circ\text{C}$ , $C_L = 1\ \mu\text{F}$ , $I_L = 500\text{ mA}$ , See Figure 1(a)	0.35	0.5	0.7	0.5	1	2	ms
$t_t$	Transition time <sup>(1)</sup>	IN1 to IN2 transition, $V_I(IN1) = 3.3\text{ V}$ , $V_I(IN2) = 5\text{ V}$	$T_J = 125^\circ\text{C}$ , $C_L = 10\ \mu\text{F}$ , $I_L = 500\text{ mA}$ [Measure transition time as 10–90% rise time or from 3.4 V to 4.8 V on $V_O(OUT)$ ], See Figure 1(b)	40	60		40	60		$\mu\text{s}$
		IN2 to IN1 transition, $V_I(IN1) = 5\text{ V}$ , $V_I(IN2) = 3.3\text{ V}$		40	60		40	60		
$t_{PLH1}$	Turn-on propagation delay from enable <sup>(1)</sup>	$V_I(IN1) = V_I(IN2) = 5\text{ V}$ Measured from enable to 10% of $V_O(OUT)$	$T_J = 25^\circ\text{C}$ , $C_L = 10\ \mu\text{F}$ , $I_L = 500\text{ mA}$ , See Figure 1(a)	0.5			1			ms
$t_{PHL1}$	Turn-off propagation delay from a disable <sup>(1)</sup>	$V_I(IN1) = V_I(IN2) = 5\text{ V}$ , Measured from disable to 90% of $V_O(OUT)$	$T_J = 25^\circ\text{C}$ , $C_L = 10\ \mu\text{F}$ , $I_L = 500\text{ mA}$ , See Figure 1(a)	3			5			ms
$t_{PLH2}$	Switch-over rising propagation delay <sup>(1)</sup>	Logic 1 to Logic 0 transition on D1, $V_I(IN1) = 1.5\text{ V}$ , $V_I(IN2) = 5\text{ V}$ , $V_I(D0) = 0\text{ V}$ , Measured from D1 to 10% of $V_O(OUT)$	$T_J = 25^\circ\text{C}$ , $C_L = 10\ \mu\text{F}$ , $I_L = 500\text{ mA}$ , See Figure 1(c)	0.17		1	0.17		1	ms
$t_{PHL2}$	Switch-over falling propagation delay <sup>(1)</sup>	Logic 0 to Logic 1 transition on D1, $V_I(IN1) = 1.5\text{ V}$ , $V_I(IN2) = 5\text{ V}$ , $V_I(D0) = 0\text{ V}$ , Measured from D1 to 90% of $V_O(OUT)$	$T_J = 25^\circ\text{C}$ , $C_L = 10\ \mu\text{F}$ , $I_L = 500\text{ mA}$ , See Figure 1(c)	2	3	10	2	5	10	ms

<sup>(1)</sup> Not tested in production.

TRUTH TABLE

D1	D0	$V_I(\text{VSNS}) > 0.8\text{V}$	$V_I(\text{IN2}) > V_I(\text{IN1})$	OUT(1)
0	0	X	X	IN2
0	1	YES	X	IN1
0	1	NO	NO	IN1
0	1	NO	YES	IN2
1	0	X	X	IN1
1	1	X	X	Hi-Z

(1) The under-voltage lockout circuit causes the output to go Hi-Z if the selected power supply does not exceed the IN1/IN2 UVLO, or if neither of the supplies exceeds the internal  $V_{DD}$  UVLO.

### Terminal Functions

TERMINAL NAME	NO.	I/O	DESCRIPTION
D0	1	I	TTL and CMOS compatible input pins. Each pin has a 1- $\mu$ A pull-up. The truth table shown above illustrates the functionality of D0 and D1.
D1	2	I	
GND	5	I	Ground
IN1	8	I	Primary power switch input. The IN1 switch can be enabled only if the IN1 supply is above the UVLO threshold and at least one supply exceeds the internal $V_{DD}$ UVLO.
IN2	6	I	Secondary power switch input. The IN2 switch can be enabled only if the IN2 supply is above the UVLO threshold and at least one supply exceeds the internal $V_{DD}$ UVLO.
ILIM	4	I	A resistor $R_{ILIM}$ from ILIM to GND sets the current limit $I_L$ to $250/R_{ILIM}$ and $500/R_{ILIM}$ for the TPS2110 and TPS2111, respectively.
OUT	7	O	Power switch output
VSNS	3	I	In the auto-switching mode (D0 = 1, D1 = 0), an internal power FET connects OUT to IN1 if the VSNS voltage is greater than 0.8 V. Otherwise, the FET connects OUT to the higher of IN1 and IN2. The truth table shown above illustrates the functionality of VSNS.

**FUNCTIONAL BLOCK DIAGRAM**

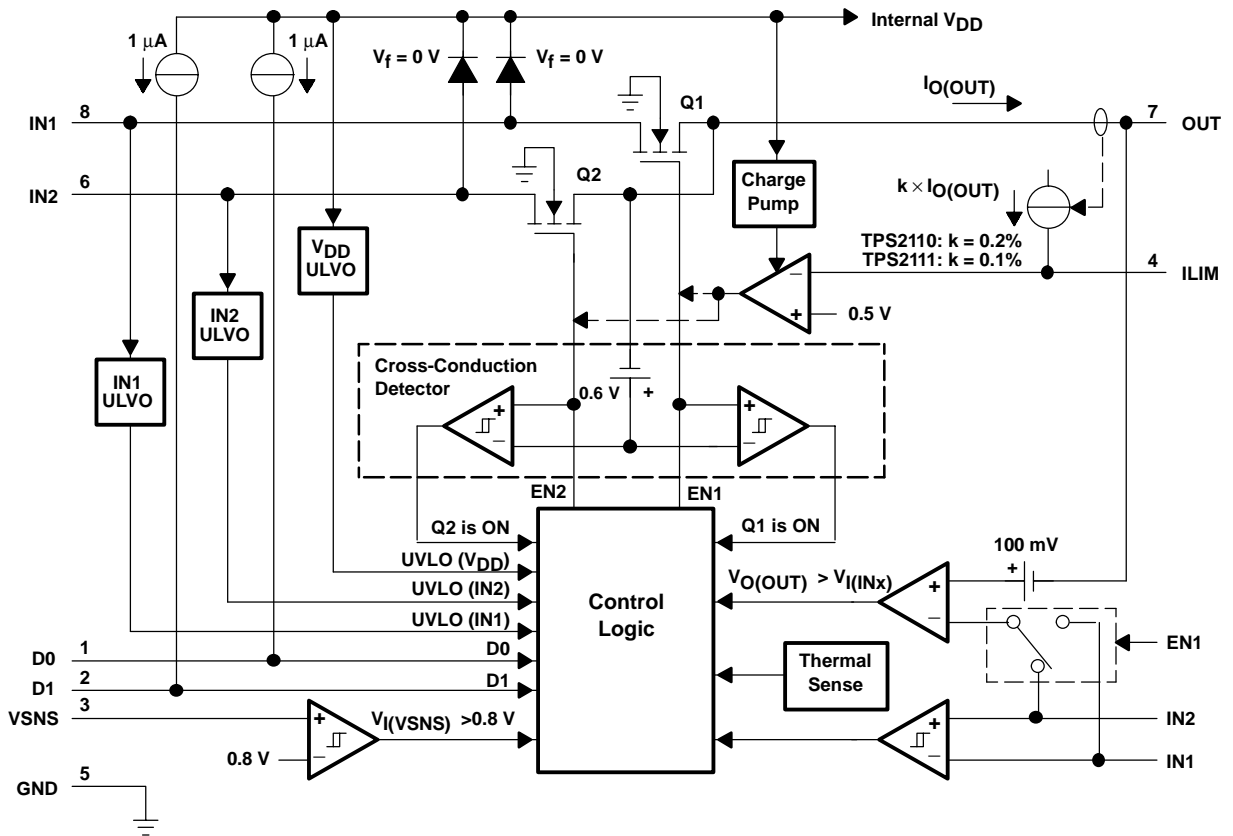

PARAMETER MEASUREMENT INFORMATION

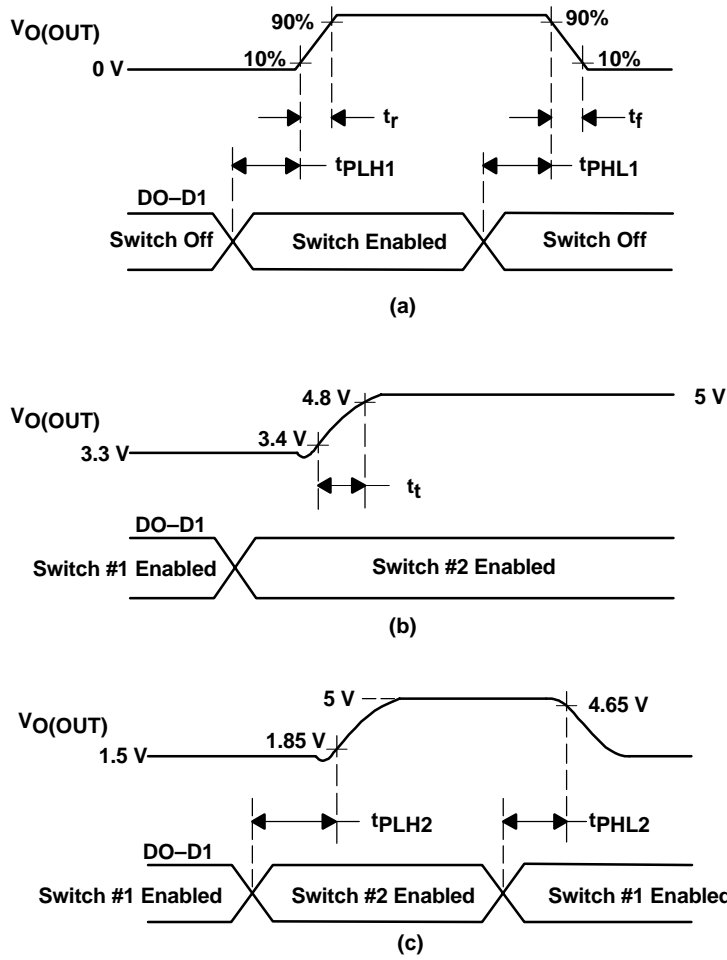
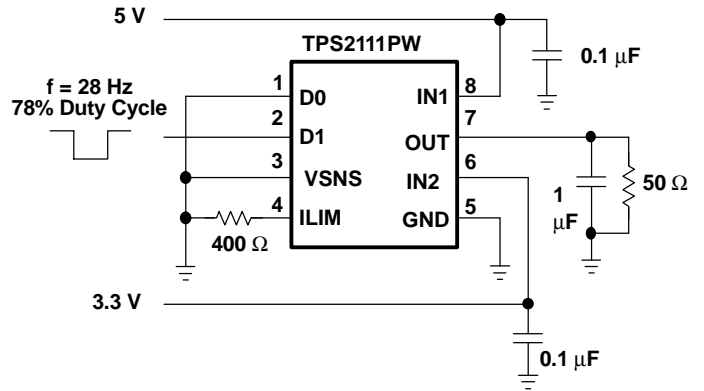
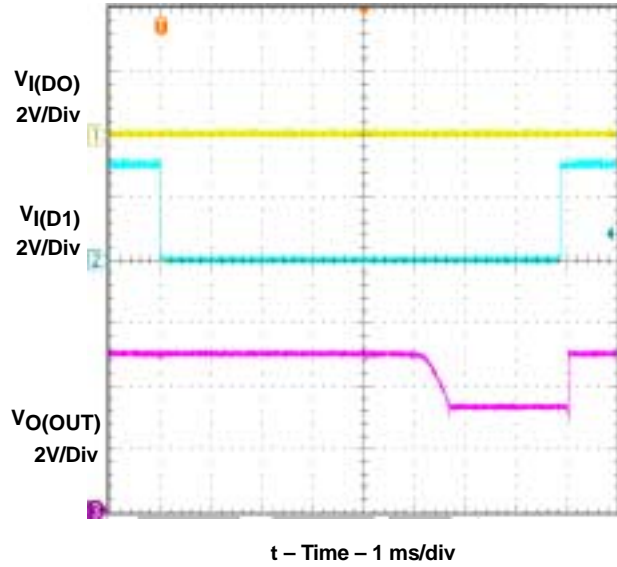

Figure 1. Propagation Delays and Transition Timing Waveforms



TYPICAL CHARACTERISTICS

OUTPUT SWITCHOVER RESPONSE



Output Switchover Response Test Circuit

Figure 2

OUTPUT TURN-ON RESPONSE

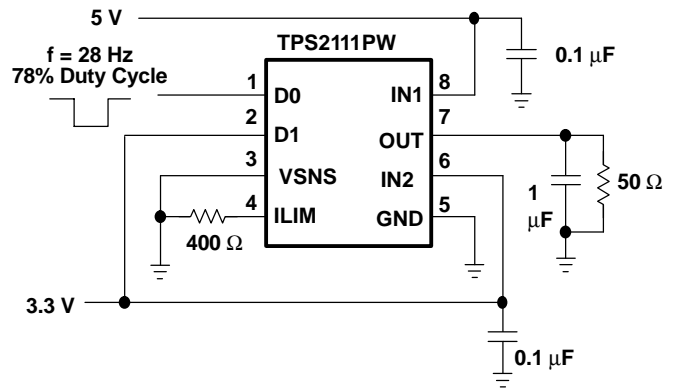
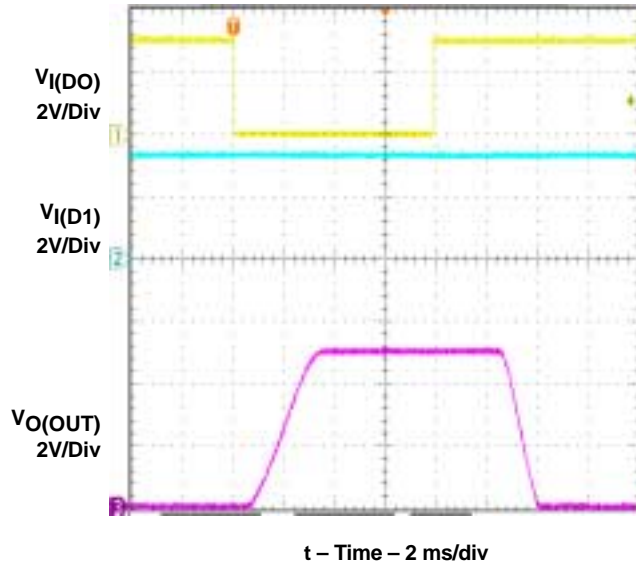

Output Turn-On Response Test Circuit

Figure 3

TYPICAL CHARACTERISTICS

OUTPUT SWITCHOVER VOLTAGE DROOP

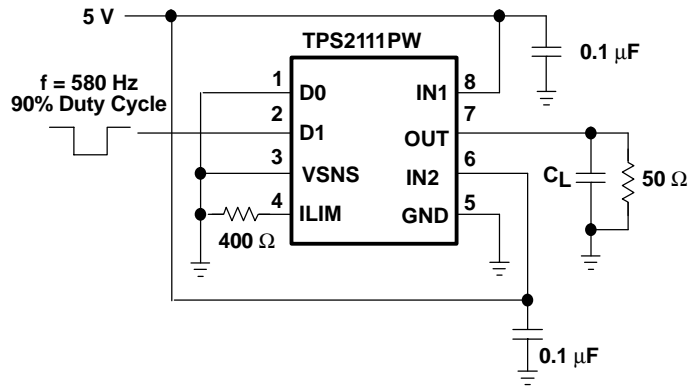
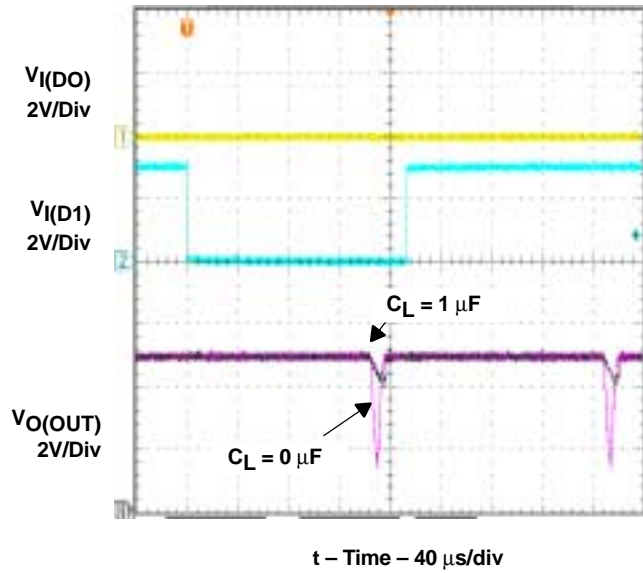

Output Switchover Voltage Droop Test Circuit

Figure 4

TYPICAL CHARACTERISTICS

OUTPUT SWITCHOVER VOLTAGE DROOP  
vs  
LOAD CAPACITANCE

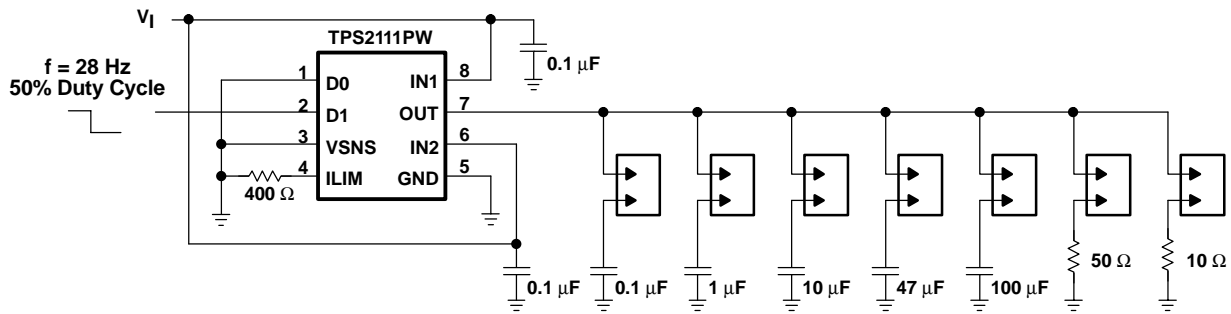
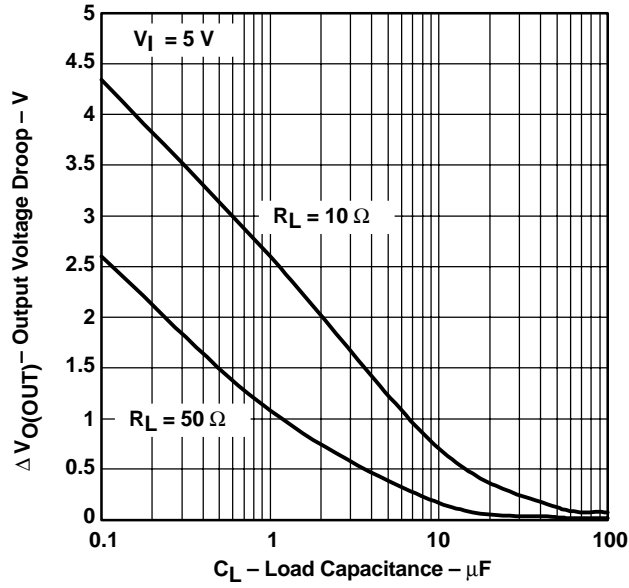

Output Switchover Voltage Droop Test Circuit

Figure 5

TYPICAL CHARACTERISTICS

INRUSH CURRENT  
VS  
LOAD CAPACITANCE

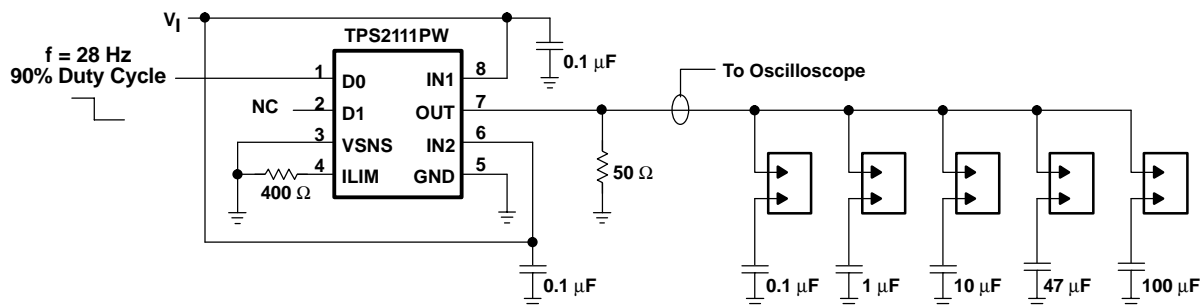
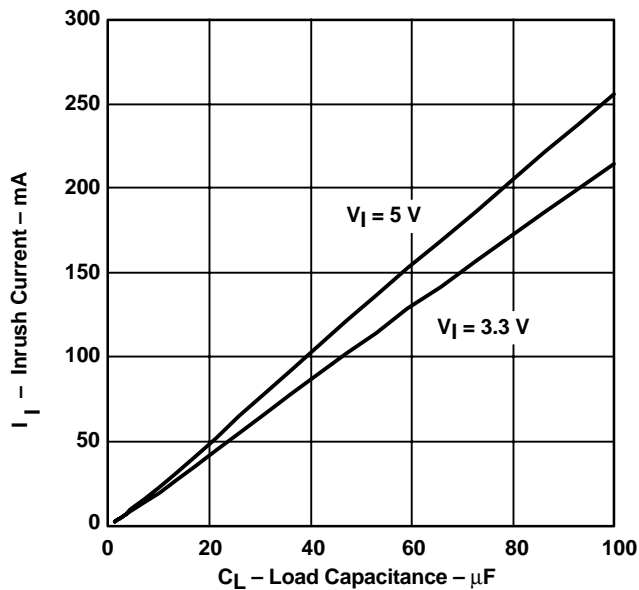

Output Capacitor Inrush Current Test Circuit

Figure 6

TYPICAL CHARACTERISTICS

SWITCH ON-RESISTANCE  
vs  
JUNCTION TEMPERATURE

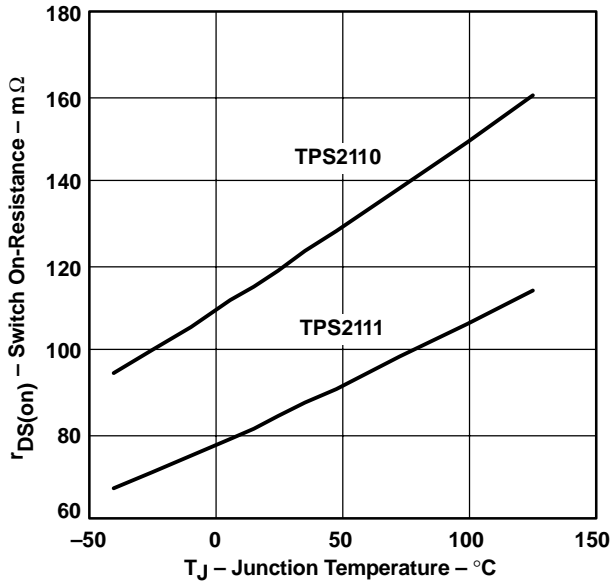

Figure 7

SWITCH ON-RESISTANCE  
vs  
SUPPLY VOLTAGE

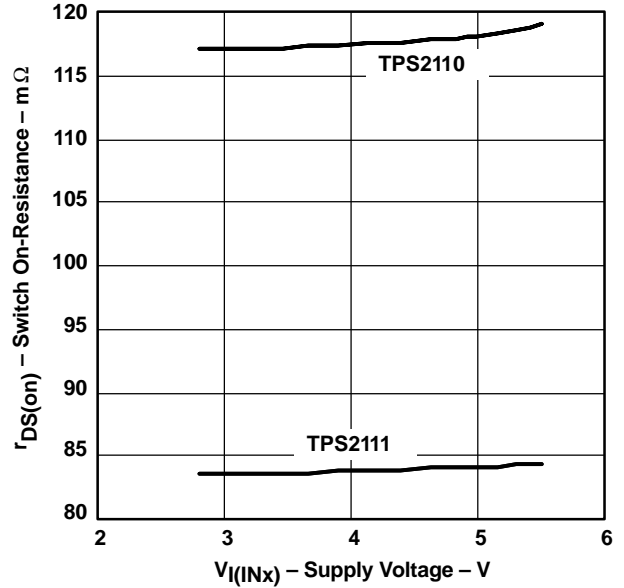

Figure 8

IN1 SUPPLY CURRENT  
vs  
SUPPLY VOLTAGE

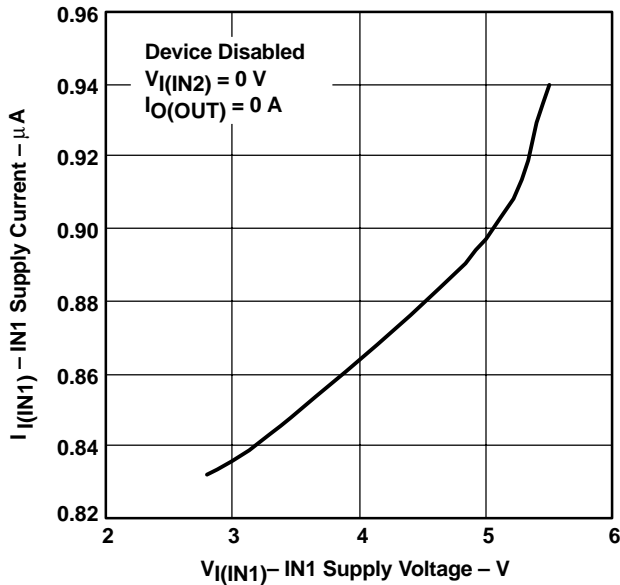

Figure 9

IN1 SUPPLY CURRENT  
vs  
SUPPLY VOLTAGE

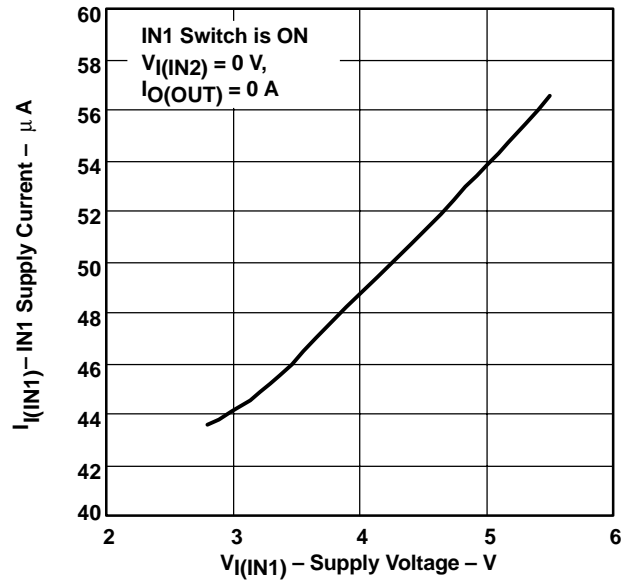

Figure 10

TYPICAL CHARACTERISTICS

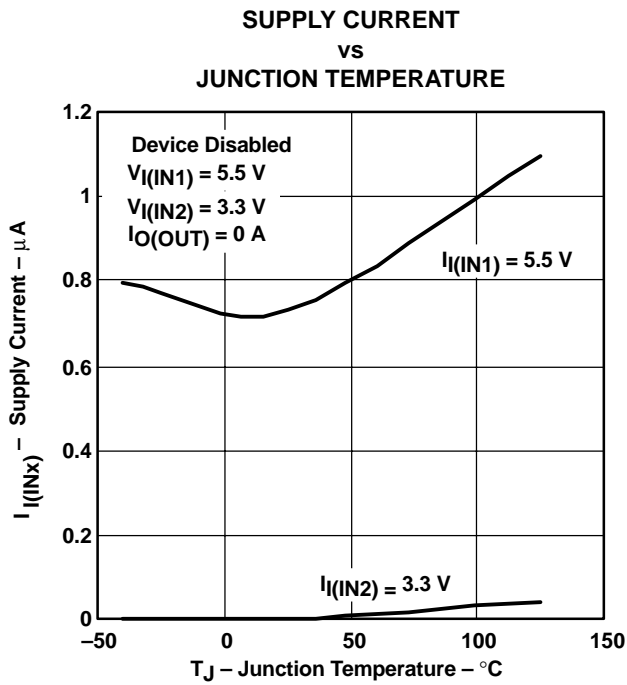

Figure 11

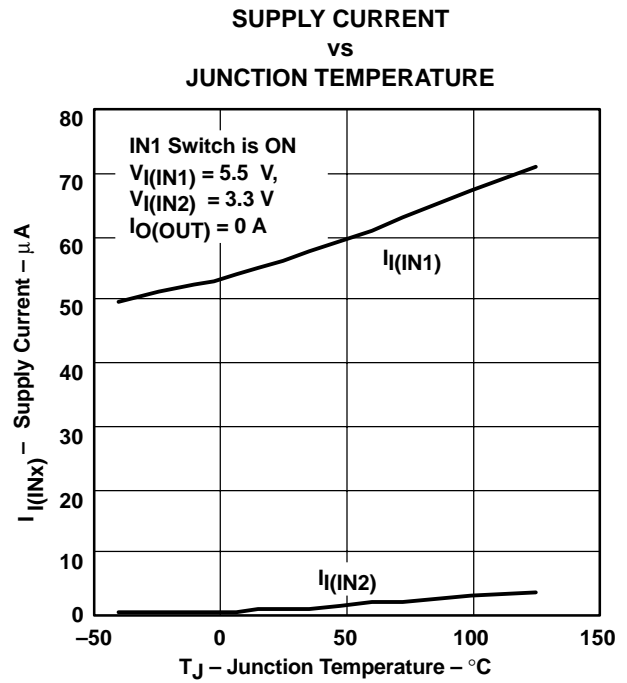
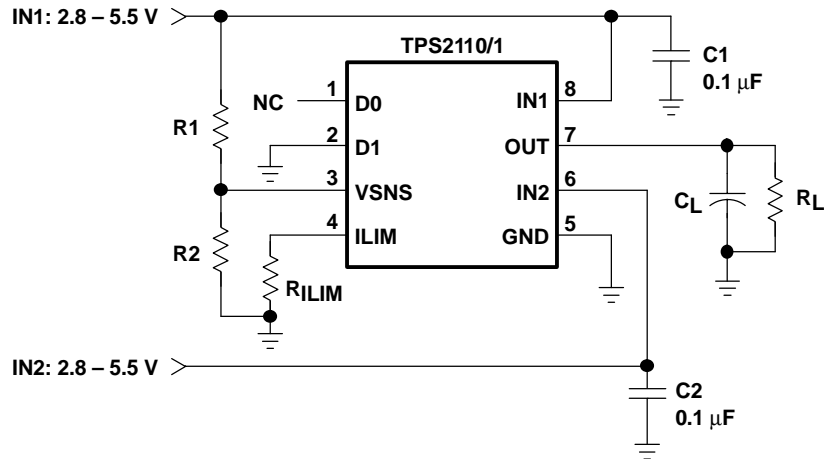

Figure 12

### APPLICATION INFORMATION

Some applications have two energy sources, one of which should be used in preference to another. Figure 13 shows a circuit that will connect IN1 to OUT until the voltage at IN1 falls below a user-specified threshold. Once the voltage on IN1 falls below this threshold, the TPS2110/1 will select the higher of the two supplies. This usually means that the TPS2110/1 will swap to IN2.



**Figure 13. Auto-Selecting for a Dual Power Supply Application**

In Figure 14, the multiplexer selects between two power supplies based upon the EN1 logic signal. OUT connects to IN1 if EN1 is logic 1, otherwise OUT connects to IN2. The logic thresholds for the D1 terminal are compatible with both TTL and CMOS logic.

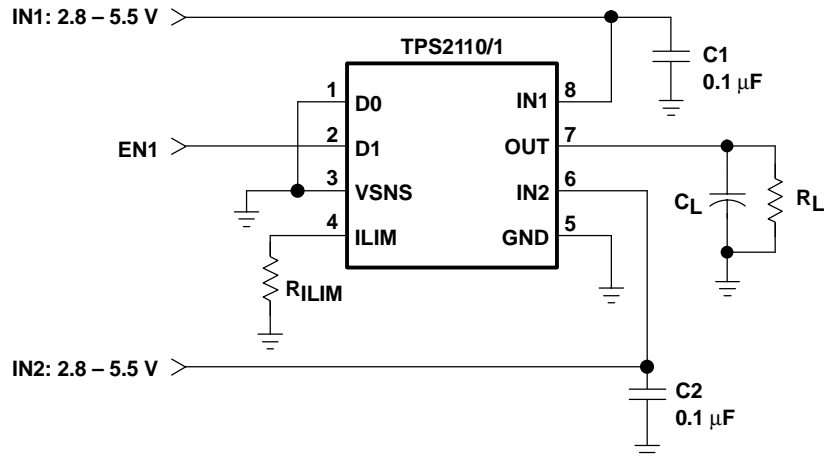

**Figure 14. Manually Switching Power Sources**

## DETAILED DESCRIPTION

### AUTO-SWITCHING MODE

D0 equal to logic 1 and D1 equal to logic 0 selects the auto-switching mode. In this mode, OUT connects to IN1 if  $V_{I(VSNS)}$  is greater than 0.8 V, otherwise OUT connects to the higher of IN1 and IN2.

The VSNS terminal includes hysteresis equal to 3.75–7.5% of the threshold selected for transition from the primary supply to the higher of the two supplies. This hysteresis helps avoid repeated switching from one supply to the other due to resistive drops.

### MANUAL SWITCHING MODE

D0 equal to logic 0 selects the manual-switching mode. In this mode, OUT connects to IN1 if D1 is equal to logic 1, otherwise OUT connects to IN2.

### N-CHANNEL MOSFETs

Two internal high-side power MOSFETs implement a single-pole double-throw (SPDT) switch. Digital logic selects the IN1 switch, IN2 switch, or no switch (Hi-Z state). The MOSFETs have no parallel diodes so output-to-input current cannot flow when the FET is off. An integrated comparator prevents turn-on of a FET switch if the output voltage is greater than the input voltage.

### CROSS-CONDUCTION BLOCKING

The switching circuitry ensures that both power switches will never conduct at the same time. A comparator monitors the gate-to-source voltage of each power FET and allows a FET to turn on only if the gate-to-source voltage of the other FET is below the turn-on threshold voltage.

### REVERSE-CONDUCTION BLOCKING

When the TPS211x switches from a higher-voltage supply to a lower-voltage supply, current can potentially flow back from the load capacitor into the lower-voltage supply. To minimize such reverse conduction, the TPS211x will not connect a supply to the output until the output voltage has fallen to within 100 mV of the supply voltage. Once a supply has been connected to the output, it will remain connected regardless of output voltage.

### CHARGE PUMP

The higher of supplies IN1 and IN2 powers the internal charge pump. The charge pump provides power to the current limit amplifier and allows the output FET gate voltage to be higher than the IN1 and IN2 supply voltages. A gate voltage that is higher than the source voltage is necessary to turn on the N-channel FET.

### CURRENT LIMITING

A resistor  $R_{ILIM}$  from ILIM to GND sets the current limit to  $250/R_{ILIM}$  and  $500/R_{ILIM}$  for the TPS2110 and TPS2111, respectively. Setting resistor  $R_{ILIM}$  equal to zero is not recommended as that disables current limiting.

### OUTPUT VOLTAGE SLEW-RATE CONTROL

The TPS2110/1 slews the output voltage at a slow rate when OUT switches to IN1 or IN2 from the Hi-Z state (see *Truth Table*). A slow slew rate limits the inrush current into the load capacitor. High inrush currents can glitch the voltage bus and cause a system to hang up or reset. It can also cause reliability issues—like pit the connector power contacts, when hot plugging a load like a PCI card. The TPS2110/1 slews the output voltage at a much faster rate when OUT switches between IN1 and IN2. The fast rate minimizes the output voltage droop and reduces the output voltage hold-up capacitance requirement.



**PACKAGING INFORMATION**

Orderable Device	Status (1)	Package Type	Package Drawing	Pins	Package Qty	Eco Plan (2)	Lead/Ball Finish	MSL Peak Temp (3)	Op Temp (°C)	Top-Side Markings (4)	Samples
TPS2110PW	ACTIVE	TSSOP	PW	8	150	Green (RoHS & no Sb/Br)	CU NIPDAU	Level-1-260C-UNLIM	-40 to 85	2110	<a href="#">Samples</a>
TPS2110PWG4	ACTIVE	TSSOP	PW	8	150	Green (RoHS & no Sb/Br)	CU NIPDAU	Level-1-260C-UNLIM	-40 to 85	2110	<a href="#">Samples</a>
TPS2110PWR	ACTIVE	TSSOP	PW	8	2000	Green (RoHS & no Sb/Br)	CU NIPDAU	Level-1-260C-UNLIM	-40 to 85	2110	<a href="#">Samples</a>
TPS2110PWRG4	ACTIVE	TSSOP	PW	8	2000	Green (RoHS & no Sb/Br)	CU NIPDAU	Level-1-260C-UNLIM	-40 to 85	2110	<a href="#">Samples</a>
TPS2111PW	ACTIVE	TSSOP	PW	8	150	Green (RoHS & no Sb/Br)	CU NIPDAU	Level-1-260C-UNLIM	-40 to 85	2111	<a href="#">Samples</a>
TPS2111PWG4	ACTIVE	TSSOP	PW	8	150	Green (RoHS & no Sb/Br)	CU NIPDAU	Level-1-260C-UNLIM	-40 to 85	2111	<a href="#">Samples</a>
TPS2111PWR	ACTIVE	TSSOP	PW	8	2000	Green (RoHS & no Sb/Br)	CU NIPDAU	Level-1-260C-UNLIM	-40 to 85	2111	<a href="#">Samples</a>
TPS2111PWRG4	ACTIVE	TSSOP	PW	8	2000	Green (RoHS & no Sb/Br)	CU NIPDAU	Level-1-260C-UNLIM	-40 to 85	2111	<a href="#">Samples</a>

(1) The marketing status values are defined as follows:

**ACTIVE:** Product device recommended for new designs.

**LIFEBUY:** TI has announced that the device will be discontinued, and a lifetime-buy period is in effect.

**NRND:** Not recommended for new designs. Device is in production to support existing customers, but TI does not recommend using this part in a new design.

**PREVIEW:** Device has been announced but is not in production. Samples may or may not be available.

**OBSOLETE:** TI has discontinued the production of the device.

(2) Eco Plan - The planned eco-friendly classification: Pb-Free (RoHS), Pb-Free (RoHS Exempt), or Green (RoHS & no Sb/Br) - please check <http://www.ti.com/productcontent> for the latest availability information and additional product content details.

**TBD:** The Pb-Free/Green conversion plan has not been defined.

**Pb-Free (RoHS):** TI's terms "Lead-Free" or "Pb-Free" mean semiconductor products that are compatible with the current RoHS requirements for all 6 substances, including the requirement that lead not exceed 0.1% by weight in homogeneous materials. Where designed to be soldered at high temperatures, TI Pb-Free products are suitable for use in specified lead-free processes.

**Pb-Free (RoHS Exempt):** This component has a RoHS exemption for either 1) lead-based flip-chip solder bumps used between the die and package, or 2) lead-based die adhesive used between the die and leadframe. The component is otherwise considered Pb-Free (RoHS compatible) as defined above.

**Green (RoHS & no Sb/Br):** TI defines "Green" to mean Pb-Free (RoHS compatible), and free of Bromine (Br) and Antimony (Sb) based flame retardants (Br or Sb do not exceed 0.1% by weight in homogeneous material)

(3) MSL, Peak Temp. -- The Moisture Sensitivity Level rating according to the JEDEC industry standard classifications, and peak solder temperature.

<sup>(4)</sup> Multiple Top-Side Markings will be inside parentheses. Only one Top-Side Marking contained in parentheses and separated by a "~" will appear on a device. If a line is indented then it is a continuation of the previous line and the two combined represent the entire Top-Side Marking for that device.

**Important Information and Disclaimer:**The information provided on this page represents TI's knowledge and belief as of the date that it is provided. TI bases its knowledge and belief on information provided by third parties, and makes no representation or warranty as to the accuracy of such information. Efforts are underway to better integrate information from third parties. TI has taken and continues to take reasonable steps to provide representative and accurate information but may not have conducted destructive testing or chemical analysis on incoming materials and chemicals. TI and TI suppliers consider certain information to be proprietary, and thus CAS numbers and other limited information may not be available for release.

In no event shall TI's liability arising out of such information exceed the total purchase price of the TI part(s) at issue in this document sold by TI to Customer on an annual basis.

**TAPE AND REEL INFORMATION**

**QUADRANT ASSIGNMENTS FOR PIN 1 ORIENTATION IN TAPE**

\*All dimensions are nominal

Device	Package Type	Package Drawing	Pins	SPQ	Reel Diameter (mm)	Reel Width W1 (mm)	A0 (mm)	B0 (mm)	K0 (mm)	P1 (mm)	W (mm)	Pin1 Quadrant
TPS2110PWR	TSSOP	PW	8	2000	330.0	12.4	7.0	3.6	1.6	8.0	12.0	Q1
TPS2111PWR	TSSOP	PW	8	2000	330.0	12.4	7.0	3.6	1.6	8.0	12.0	Q1

**TAPE AND REEL BOX DIMENSIONS**

\*All dimensions are nominal

Device	Package Type	Package Drawing	Pins	SPQ	Length (mm)	Width (mm)	Height (mm)
TPS2110PWR	TSSOP	PW	8	2000	367.0	367.0	35.0
TPS2111PWR	TSSOP	PW	8	2000	367.0	367.0	35.0

PW0008A



**PACKAGE OUTLINE**  
**TSSOP - 1.2 mm max height**

SMALL OUTLINE PACKAGE



4221848/A 02/2015

NOTES:

- All linear dimensions are in millimeters. Any dimensions in parenthesis are for reference only. Dimensioning and tolerancing per ASME Y14.5M.
- This drawing is subject to change without notice.
- This dimension does not include mold flash, protrusions, or gate burrs. Mold flash, protrusions, or gate burrs shall not exceed 0.15 mm per side.
- This dimension does not include interlead flash. Interlead flash shall not exceed 0.25 mm per side.
- Reference JEDEC registration MO-153, variation AA.

# EXAMPLE BOARD LAYOUT

PW0008A

TSSOP - 1.2 mm max height

SMALL OUTLINE PACKAGE



LAND PATTERN EXAMPLE  
SCALE:10X



SOLDER MASK DETAILS  
NOT TO SCALE

4221848/A 02/2015

NOTES: (continued)

- 6. Publication IPC-7351 may have alternate designs.
- 7. Solder mask tolerances between and around signal pads can vary based on board fabrication site.

# EXAMPLE STENCIL DESIGN

PW0008A

TSSOP - 1.2 mm max height

SMALL OUTLINE PACKAGE



SOLDER PASTE EXAMPLE  
BASED ON 0.125 mm THICK STENCIL  
SCALE:10X

4221848/A 02/2015

NOTES: (continued)

8. Laser cutting apertures with trapezoidal walls and rounded corners may offer better paste release. IPC-7525 may have alternate design recommendations.
9. Board assembly site may have different recommendations for stencil design.

## IMPORTANT NOTICE

Texas Instruments Incorporated and its subsidiaries (TI) reserve the right to make corrections, enhancements, improvements and other changes to its semiconductor products and services per JESD46, latest issue, and to discontinue any product or service per JESD48, latest issue. Buyers should obtain the latest relevant information before placing orders and should verify that such information is current and complete. All semiconductor products (also referred to herein as "components") are sold subject to TI's terms and conditions of sale supplied at the time of order acknowledgment.

TI warrants performance of its components to the specifications applicable at the time of sale, in accordance with the warranty in TI's terms and conditions of sale of semiconductor products. Testing and other quality control techniques are used to the extent TI deems necessary to support this warranty. Except where mandated by applicable law, testing of all parameters of each component is not necessarily performed.

TI assumes no liability for applications assistance or the design of Buyers' products. Buyers are responsible for their products and applications using TI components. To minimize the risks associated with Buyers' products and applications, Buyers should provide adequate design and operating safeguards.

TI does not warrant or represent that any license, either express or implied, is granted under any patent right, copyright, mask work right, or other intellectual property right relating to any combination, machine, or process in which TI components or services are used. Information published by TI regarding third-party products or services does not constitute a license to use such products or services or a warranty or endorsement thereof. Use of such information may require a license from a third party under the patents or other intellectual property of the third party, or a license from TI under the patents or other intellectual property of TI.

Reproduction of significant portions of TI information in TI data books or data sheets is permissible only if reproduction is without alteration and is accompanied by all associated warranties, conditions, limitations, and notices. TI is not responsible or liable for such altered documentation. Information of third parties may be subject to additional restrictions.

Resale of TI components or services with statements different from or beyond the parameters stated by TI for that component or service voids all express and any implied warranties for the associated TI component or service and is an unfair and deceptive business practice. TI is not responsible or liable for any such statements.

Buyer acknowledges and agrees that it is solely responsible for compliance with all legal, regulatory and safety-related requirements concerning its products, and any use of TI components in its applications, notwithstanding any applications-related information or support that may be provided by TI. Buyer represents and agrees that it has all the necessary expertise to create and implement safeguards which anticipate dangerous consequences of failures, monitor failures and their consequences, lessen the likelihood of failures that might cause harm and take appropriate remedial actions. Buyer will fully indemnify TI and its representatives against any damages arising out of the use of any TI components in safety-critical applications.

In some cases, TI components may be promoted specifically to facilitate safety-related applications. With such components, TI's goal is to help enable customers to design and create their own end-product solutions that meet applicable functional safety standards and requirements. Nonetheless, such components are subject to these terms.

No TI components are authorized for use in FDA Class III (or similar life-critical medical equipment) unless authorized officers of the parties have executed a special agreement specifically governing such use.

Only those TI components which TI has specifically designated as military grade or "enhanced plastic" are designed and intended for use in military/aerospace applications or environments. Buyer acknowledges and agrees that any military or aerospace use of TI components which have **not** been so designated is solely at the Buyer's risk, and that Buyer is solely responsible for compliance with all legal and regulatory requirements in connection with such use.

TI has specifically designated certain components as meeting ISO/TS16949 requirements, mainly for automotive use. In any case of use of non-designated products, TI will not be responsible for any failure to meet ISO/TS16949.

### Products

Audio	<a href="http://www.ti.com/audio">www.ti.com/audio</a>
Amplifiers	<a href="http://amplifier.ti.com">amplifier.ti.com</a>
Data Converters	<a href="http://dataconverter.ti.com">dataconverter.ti.com</a>
DLP® Products	<a href="http://www.dlp.com">www.dlp.com</a>
DSP	<a href="http://dsp.ti.com">dsp.ti.com</a>
Clocks and Timers	<a href="http://www.ti.com/clocks">www.ti.com/clocks</a>
Interface	<a href="http://interface.ti.com">interface.ti.com</a>
Logic	<a href="http://logic.ti.com">logic.ti.com</a>
Power Mgmt	<a href="http://power.ti.com">power.ti.com</a>
Microcontrollers	<a href="http://microcontroller.ti.com">microcontroller.ti.com</a>
RFID	<a href="http://www.ti-rfid.com">www.ti-rfid.com</a>
OMAP Applications Processors	<a href="http://www.ti.com/omap">www.ti.com/omap</a>
Wireless Connectivity	<a href="http://www.ti.com/wirelessconnectivity">www.ti.com/wirelessconnectivity</a>

### Applications

Automotive and Transportation	<a href="http://www.ti.com/automotive">www.ti.com/automotive</a>
Communications and Telecom	<a href="http://www.ti.com/communications">www.ti.com/communications</a>
Computers and Peripherals	<a href="http://www.ti.com/computers">www.ti.com/computers</a>
Consumer Electronics	<a href="http://www.ti.com/consumer-apps">www.ti.com/consumer-apps</a>
Energy and Lighting	<a href="http://www.ti.com/energy">www.ti.com/energy</a>
Industrial	<a href="http://www.ti.com/industrial">www.ti.com/industrial</a>
Medical	<a href="http://www.ti.com/medical">www.ti.com/medical</a>
Security	<a href="http://www.ti.com/security">www.ti.com/security</a>
Space, Avionics and Defense	<a href="http://www.ti.com/space-avionics-defense">www.ti.com/space-avionics-defense</a>
Video and Imaging	<a href="http://www.ti.com/video">www.ti.com/video</a>

### TI E2E Community

[e2e.ti.com](http://e2e.ti.com)