

## 3.2 W Mono Class-D Audio Power Amplifier With Selectable Gain and Auto-Recovering Short-Circuit Protection

Check for Samples: [TPA2038D1](#)

### FEATURES

- Filter-Free Mono Class-D Speaker Amp
- GAIN Pin Selects Between 6 dB and 12 dB
- 3.2 W into 4 Ω from 5 V supply at 10% THD+N
- Powerful Mono Class-D Speaker Amplifier
  - 1% at 1.4 W into 8 Ω from 5 V Supply
  - 1% at 2.5 W into 4 Ω from 5 V Supply
- Integrated Image Reject Filter for DAC Noise Reduction
- Low Output Noise of 20 μV
- Low Quiescent Current of 1.5 mA
- Auto-Recovering Short-Circuit Protection
- Thermal-Overload Protection
- 9-Ball 1,21 mm × 1,16 mm 0,4 mm Pitch WCSP

### APPLICATIONS

- Wireless or Cellular Handsets and PDAs
- Portable Navigation Devices
- General Portable Audio Devices

### DESCRIPTION

The TPA2038D1 is a 3.2 W into 8-ohm (10% THD) high efficiency filter-free class-D audio power amplifier. The GAIN pin sets gain to either 6 dB or 12 dB.

Features like 95% efficiency, 1.5 mA quiescent current, 0.5 μA shutdown current, 81 dB PSRR, 20 μV output noise, and improved RF immunity make the TPA2038D1 class-D amplifier ideal for cellular handsets. A start-up time is within 4 ms with no turn-on pop.

The TPA2038D1 is available in a 1.21 mm x 1.16 mm, 0.4 mm pitch wafer chip scale package (WCSP).

### APPLICATION CIRCUIT

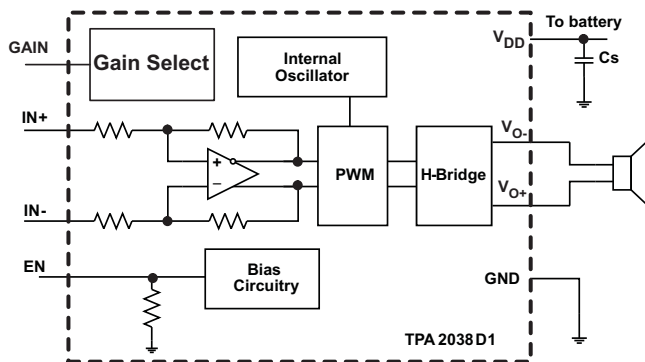

**TPA2038D1**  
9-BALL 0.4mm PITCH  
WAFER CHIP SCALE PACKAGE (YFF)  
(TOP VIEW OF PCB)

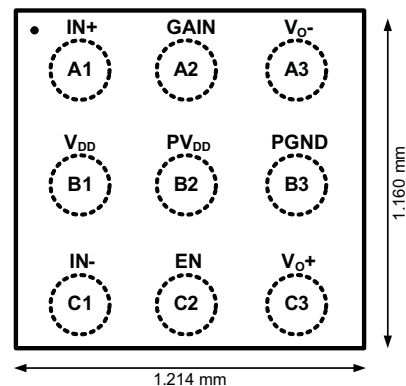

Please be aware that an important notice concerning availability, standard warranty, and use in critical applications of Texas Instruments semiconductor products and disclaimers thereto appears at the end of this data sheet.

# TPA2038D1

SLOS697 –AUGUST 2011

www.ti.com



These devices have limited built-in ESD protection. The leads should be shorted together or the device placed in conductive foam during storage or handling to prevent electrostatic damage to the MOS gates.

## ORDERING INFORMATION

| T <sub>A</sub> | PACKAGED DEVICES <sup>(1)</sup> | PART NUMBER <sup>(2)</sup> | SYMBOL |
|----------------|---------------------------------|----------------------------|--------|
| -40°C to 85°C  | 9-ball WCSP                     | TPA2038D1YFFR              | QWK    |
|                |                                 | TPA2038D1YFFT              | QWK    |

- (1) For the most current package and ordering information, see the Package Option Addendum at the end of this document, or see the TI Web site at [www.ti.com](http://www.ti.com)
- (2) The YFF package is only available taped and reeled. The suffix "R" indicates a reel of 3000, the suffix "T" indicates a reel of 250.

## ABSOLUTE MAXIMUM RATINGS

over operating free-air temperature range, T<sub>A</sub> = 25°C (unless otherwise noted)<sup>(1)</sup>

|                                    |   |                  | VALUE                         | UNIT |
|------------------------------------|---|------------------|-------------------------------|------|
| V <sub>DD</sub> , PV <sub>DD</sub> | Supply voltage                            | In active mode   | -0.3 to 6.0                   | V    |
|                                    |   | In shutdown mode | -0.3 to 6.0                   | V    |
| V <sub>I</sub>                     | Input voltage                             | EN, IN+, IN-     | -0.3 to V <sub>DD</sub> + 0.3 | V    |
| R <sub>L</sub>                     | Minimum load resistance                   |                  | 3.2                           | Ω    |
|                                    | Output continuous total power dissipation |                  | See Dissipation Rating Table  |      |
| T <sub>A</sub>                     | Operating free-air temperature range      |                  | -40 to 85                     | °C   |
| T <sub>J</sub>                     | Operating junction temperature range      |                  | -40 to 150                    | °C   |
| T <sub>stg</sub>                   | Storage temperature range                 |                  | -65 to 85                     | °C   |

- (1) Stresses beyond those listed under *absolute maximum ratings* may cause permanent damage to the device. These are stress ratings only, and functional operation of the device at these or any other conditions beyond those indicated under *recommended operating conditions* is not implied. Exposure to Absolute Maximum Ratings conditions for extended periods may affect device reliability.

## DISSIPATION RATINGS

| PACKAGE    | DERATING FACTOR <sup>(1)</sup> | T <sub>A</sub> < 25°C | T <sub>A</sub> = 70°C | T <sub>A</sub> = 85°C |
|------------|--------------------------------|-----------------------|-----------------------|-----------------------|
| YFF (WCSP) | 4.2 mW/°C                      | 525 mW                | 336 mW                | 273 mW                |

- (1) Derating factor measure with high K board.

## RECOMMENDED OPERATING CONDITIONS

|                                    |                                 |  | MIN  | MAX                  | UNIT |
|------------------------------------|---------------------------------|--|------|----------------------|------|
| V <sub>DD</sub> , PV <sub>DD</sub> | Class-D supply voltage          |  | 2.5  | 5.5                  | V    |
| V <sub>IH</sub>                    | High-level input voltage        | EN, GAIN                                     | 1.3  |                      | V    |
| V <sub>IL</sub>                    | Low-level input voltage         | EN, GAIN                                     |      | 0.35                 | V    |
| V <sub>IC</sub>                    | Common mode input voltage range | V <sub>DD</sub> = 2.5 V, 5.5 V, CMRR ≥ 49 dB | 0.75 | V <sub>DD</sub> -1.1 | V    |
| T <sub>A</sub>                     | Operating free-air temperature  |  | -40  | 85                   | °C   |

## GAIN SETTING

| GAIN PIN | GAIN SETTING |
|----------|--------------|
| GND      | 12 dB        |
| VDD      | 6 dB         |

**ELECTRICAL CHARACTERISTICS**

PVDD = VDD = 3.6 V, T<sub>A</sub> = 25°C (unless otherwise noted)

| PARAMETER          |   | TEST CONDITIONS                  | MIN  | TYP | MAX  | UNIT |
|--------------------|---|----------------------------------|------|-----|------|------|
| V <sub>OS</sub>    | Output offset voltage (measured differentially) | VDD = 2.5 V to 5.5 V, GAIN = VDD |      | 1   | 5    | mV   |
| I <sub>IH</sub>    | High-level EN input current                     | VDD = 5.5 V, EN = GAIN = 5.5 V   |      |     | 50   | μA   |
| I <sub>IL</sub>    | Low-level EN input current                      | VDD = 5.5 V, EN = GAIN = 0 V     |      |     | 1    | μA   |
| I <sub>(Q)</sub>   | Quiescent current                               | VDD = 5.5 V, no load             |      | 1.8 | 2.5  | mA   |
|                    |   | VDD = 3.6 V, no load             |      | 1.5 | 2.3  |      |
|                    |   | VDD = 2.5 V, no load             |      | 1.3 | 2.1  |      |
| I <sub>(SD)</sub>  | Shutdown current                                | EN = 0.35 V, VDD = 3.6 V         |      | 0.1 | 2    | μA   |
| R <sub>O, SD</sub> | Output impedance in shutdown mode               | EN = 0.35 V                      |      | 2   |      | kΩ   |
| f <sub>(SW)</sub>  | Switching frequency                             | VDD = 2.5 V to 5.5 V             | 250  | 300 | 350  | kHz  |
| A <sub>V</sub>     | Gain  | GAIN = 0 V                       | 11.5 | 12  | 12.5 | dB   |
|                    |   | GAIN = VDD                       | 5.5  | 6   | 6.5  |      |
| R <sub>EN</sub>    | Resistance from EN to GND                       |                                  |      | 300 |      | kΩ   |
| R <sub>IN</sub>    | Single-ended input resistance                   | A <sub>V</sub> = 6 dB; EN = VDD  |      | 150 |      | kΩ   |
|                    |   | A <sub>V</sub> = 12 dB; EN = VDD |      | 75  |      |      |
|                    |   | EN = 0.35 V                      |      | 75  |      |      |

**OPERATING CHARACTERISTICS**

PVDD = VDD = 3.6 V, A<sub>V</sub> = 6 dB, T<sub>A</sub> = 25°C, R<sub>L</sub> = 8 Ω (unless otherwise noted)

| PARAMETER      |  | TEST CONDITIONS  | MIN                     | TYP   | MAX | UNIT              |
|----------------|--|--|-------------------------|-------|-----|-------------------|
| P <sub>O</sub> | Output power                                 | THD + N = 10%, f = 1 kHz, R <sub>L</sub> = 4 Ω   | V <sub>DD</sub> = 5 V   | 3.24  |     | W                 |
|                |  |  | V <sub>DD</sub> = 3.6 V | 1.62  |     |                   |
|                |  |  | V <sub>DD</sub> = 2.5 V | 0.70  |     |                   |
|                |  | THD + N = 1%, f = 1 kHz, R <sub>L</sub> = 4 Ω  | V <sub>DD</sub> = 5 V   | 2.57  |     | W                 |
|                |  |  | V <sub>DD</sub> = 3.6 V | 1.32  |     |                   |
|                |  |  | V <sub>DD</sub> = 2.5 V | 0.57  |     |                   |
|                |  | THD + N = 10%, f = 1 kHz, R <sub>L</sub> = 8 Ω   | V <sub>DD</sub> = 5 V   | 1.80  |     | W                 |
|                |  |  | V <sub>DD</sub> = 3.6 V | 0.91  |     |                   |
|                |  |  | V <sub>DD</sub> = 2.5 V | 0.42  |     |                   |
|                |  | THD + N = 1%, f = 1 kHz, R <sub>L</sub> = 8 Ω  | V <sub>DD</sub> = 5 V   | 1.46  |     | W                 |
|                |  |  | V <sub>DD</sub> = 3.6 V | 0.74  |     |                   |
|                |  |  | V <sub>DD</sub> = 2.5 V | 0.33  |     |                   |
| E <sub>N</sub> | Output voltage noise, A <sub>V</sub> = 6 dB  | V <sub>DD</sub> = 3.6 V, Inputs AC grounded with C <sub>1</sub> = 2 μF, f = 20 Hz to 20 kHz                    | A-weighting             | 20    |     | μV <sub>RMS</sub> |
|                |  |  | No weighting            | 26    |     |                   |
|                | Output voltage noise, A <sub>V</sub> = 12 dB |  | A-weighting             | 27    |     |                   |
|                |  |  | No weighting            | 36    |     |                   |
| THD+N          | Total harmonic distortion plus noise         | VDD = 5.0 V, P <sub>O</sub> = 1.0 W, f = 1 kHz, R <sub>L</sub> = 8 Ω   |                         | 0.12% |     |                   |
|                |  | VDD = 3.6 V, P <sub>O</sub> = 0.5 W, f = 1 kHz, R <sub>L</sub> = 8 Ω   |                         | 0.05% |     |                   |
|                |  | VDD = 2.5 V, P <sub>O</sub> = 0.2 W, f = 1 kHz, R <sub>L</sub> = 8 Ω   |                         | 0.05% |     |                   |
|                |  | VDD = 5.0 V, P <sub>O</sub> = 2.0 W, f = 1 kHz, R <sub>L</sub> = 4 Ω   |                         | 0.32% |     |                   |
|                |  | VDD = 3.6 V, P <sub>O</sub> = 1.0 W, f = 1 kHz, R <sub>L</sub> = 4 Ω   |                         | 0.11% |     |                   |
|                |  | VDD = 2.5 V, P <sub>O</sub> = 0.4 W, f = 1 kHz, R <sub>L</sub> = 4 Ω   |                         | 0.12% |     |                   |
| PSRR           | AC power supply rejection ratio              | A <sub>V</sub> = 6 dB, Inputs AC grounded with C <sub>1</sub> = 2 μF, 200 mV <sub>pp</sub> ripple, f = 217 Hz  |                         | 81    |     | dB                |
|                |  | A <sub>V</sub> = 12 dB, Inputs AC grounded with C <sub>1</sub> = 2 μF, 200 mV <sub>pp</sub> ripple, f = 217 Hz |                         | 82    |     |                   |

# TPA2038D1

SLOS697 –AUGUST 2011

www.ti.com

## OPERATING CHARACTERISTICS (continued)

PVDD = VDD = 3.6 V,  $A_V = 6$  dB,  $T_A = 25^\circ\text{C}$ ,  $R_L = 8 \Omega$  (unless otherwise noted)

| PARAMETER |                                    | TEST CONDITIONS   | MIN | TYP | MAX | UNIT |
|-----------|------------------------------------|---|-----|-----|-----|------|
| CMRR      | Common mode rejection ratio        | $A_V = 6$ dB, $V_{IC} = 200$ mV <sub>PP</sub> , $f = 217$ Hz  |     | 79  |     | dB   |
|           |                                    | $A_V = 12$ dB, $V_{IC} = 200$ mV <sub>PP</sub> , $f = 217$ Hz |     | 77  |     |      |
| $T_{SU}$  | Startup time from shutdown         |   |     | 4   |     | ms   |
| $I_{SC}$  | Short circuit protection threshold | $V_{O+}$ shorted to VDD                                       |     | 2   |     | A    |
|           |                                    | $V_{O-}$ shorted to VDD                                       |     |     |     |      |
|           |                                    | $V_{O+}$ shorted to GND                                       |     |     |     |      |
|           |                                    | $V_{O-}$ shorted to GND                                       |     |     |     |      |
|           |                                    | $V_{O+}$ shorted to $V_{O-}$                                  |     |     |     |      |
| $T_{AR}$  | Overcurrent recovery time          | VDD = 2.5 V to 5.5 V  |     | 100 |     | ms   |

## Terminal Functions

| TERMINAL |           | I/O | DESCRIPTION  |
|----------|-----------|-----|--|
| NAME     | WCSP BALL |     |  |
| IN+      | A1        | I   | Positive audio input.  |
| GAIN     | A2        | I   | Gain select. Set to GND for 12 dB; set to VDD for 6 dB.                |
| $V_{O-}$ | A3        | O   | Negative audio output.   |
| VDD      | B1        | I   | Power supply terminal. Connect to PVDD using a direct connection.      |
| PVDD     | B2        | I   | Class-D output power supply. Connect to VDD using a direct connection. |
| GND      | B3        | I   | Ground.  |
| IN-      | C1        | I   | Negative audio input.  |
| EN       | C2        | I   | Enable. Set to logic high to enable device.                            |
| $V_{O+}$ | C3        | O   | Positive audio output.   |

## FUNCTIONAL BLOCK DIAGRAM

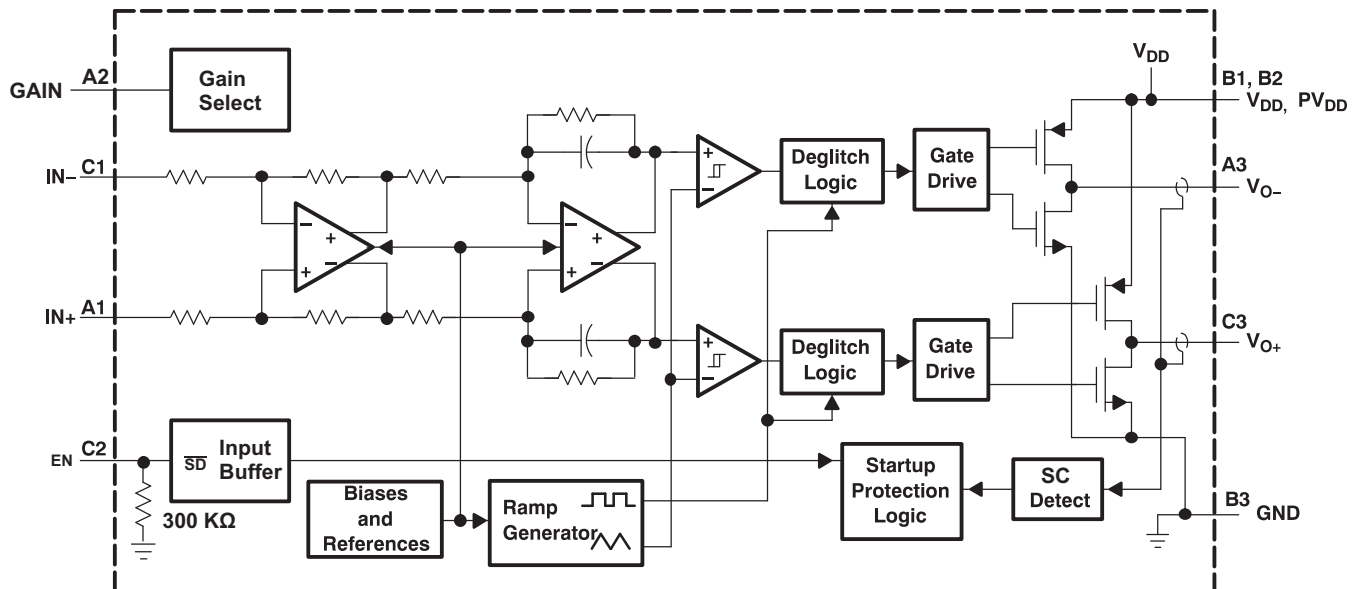

### TEST SETUP FOR GRAPHS

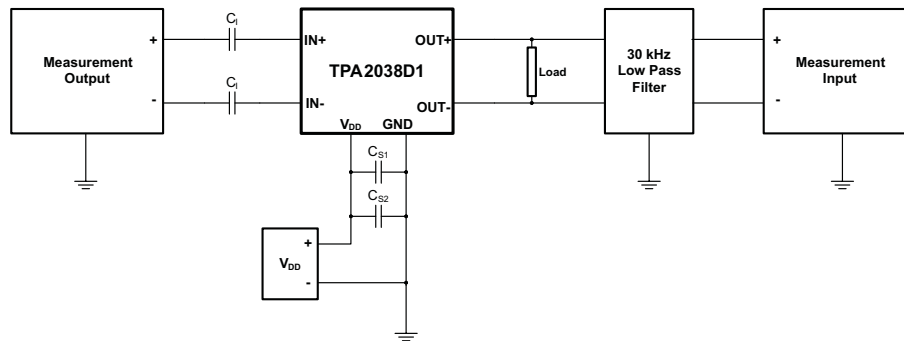

1.  $C_1$  was shorted for any common-mode input voltage measurement. All other measurements were taken with  $C_1 = 0.1 \mu\text{F}$  (unless otherwise noted).
2.  $C_{S1} = 0.1 \mu\text{F}$  is placed very close to the device. The optional  $C_{S2} = 10 \mu\text{F}$  is used for datasheet graphs.
3. The 30 kHz low-pass filter is required even if the analyzer has an internal low-pass filter. An RC low-pass filter (1 k $\Omega$ , 4700 pF) is used on each output for the data sheet graphs.

**TYPICAL CHARACTERISTICS**

PVDD = VDD = 3.6 V, C<sub>I</sub> = 0.1 μF, C<sub>S1</sub> = 0.1 μF, C<sub>S2</sub> = 10 μF, T<sub>A</sub> = 25°C, R<sub>L</sub> = 8 Ω (unless otherwise noted)

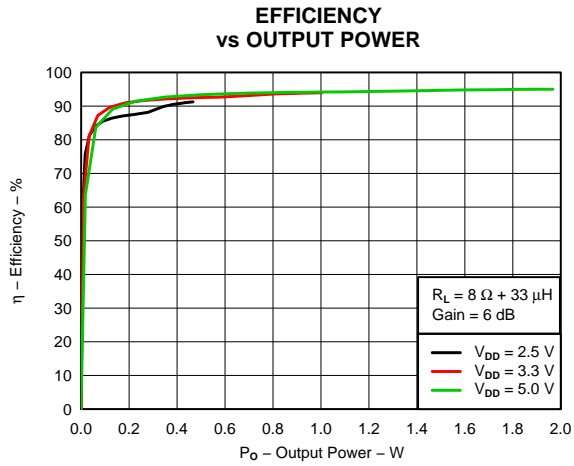

Figure 1.

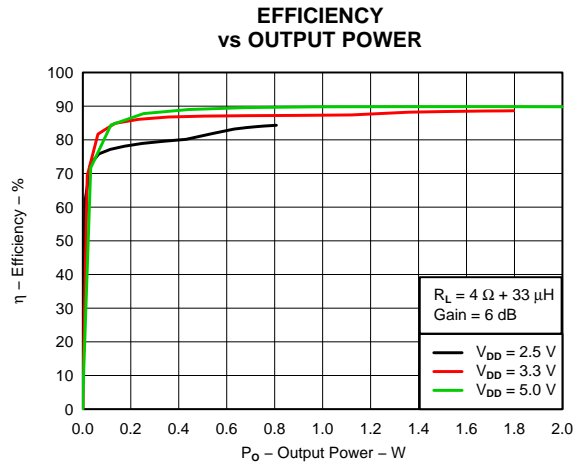

Figure 2.

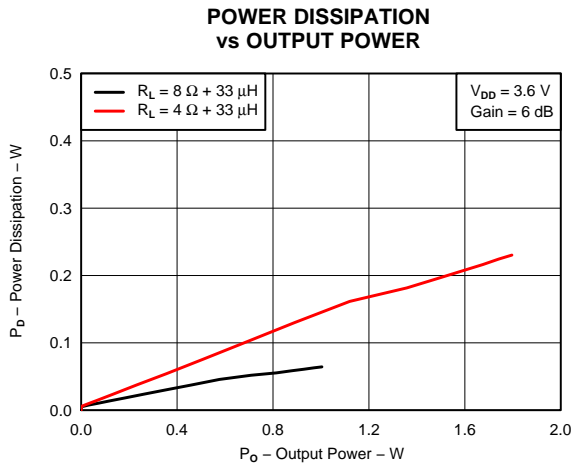

Figure 3.

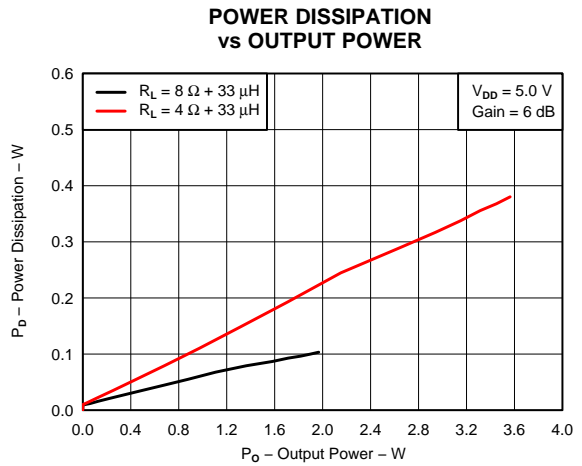

Figure 4.

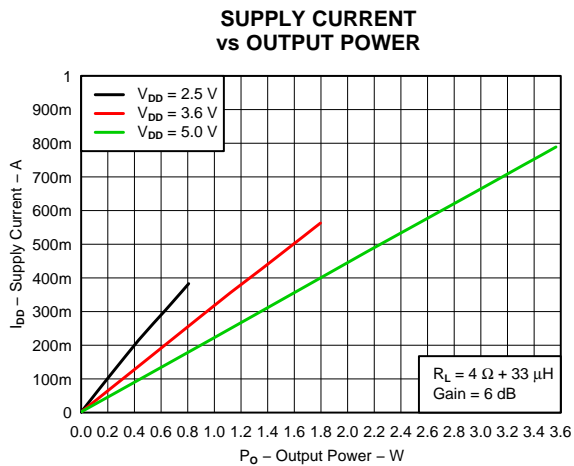

Figure 5.

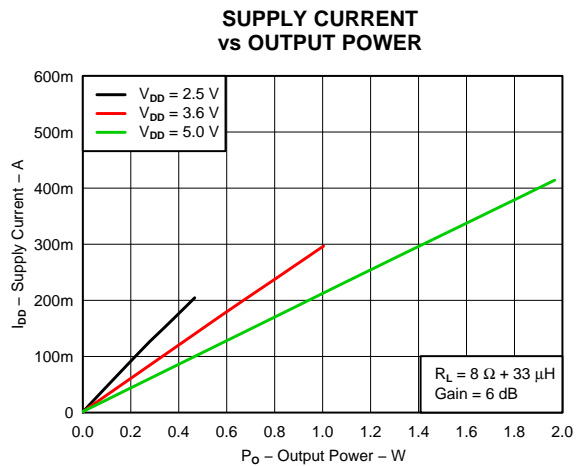
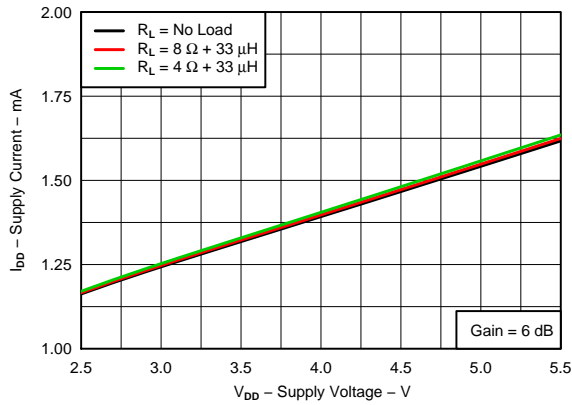

Figure 6.

**TYPICAL CHARACTERISTICS (continued)**

PVDD = VDD = 3.6 V, C<sub>I</sub> = 0.1 μF, C<sub>S1</sub> = 0.1 μF, C<sub>S2</sub> = 10 μF, T<sub>A</sub> = 25°C, R<sub>L</sub> = 8 Ω (unless otherwise noted)

**SUPPLY CURRENT vs SUPPLY VOLTAGE**



**Figure 7.**

**SUPPLY CURRENT vs EN VOLTAGE**

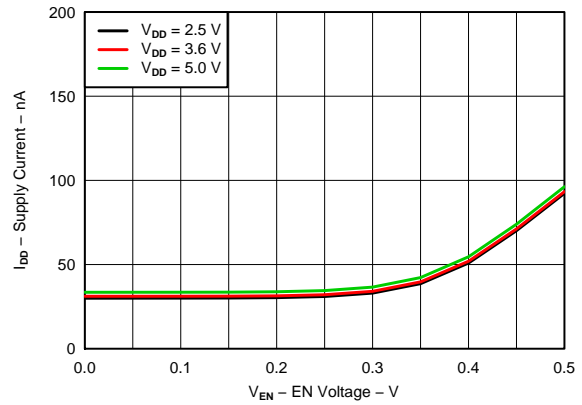

**Figure 8.**

**OUTPUT POWER vs LOAD RESISTANCE**

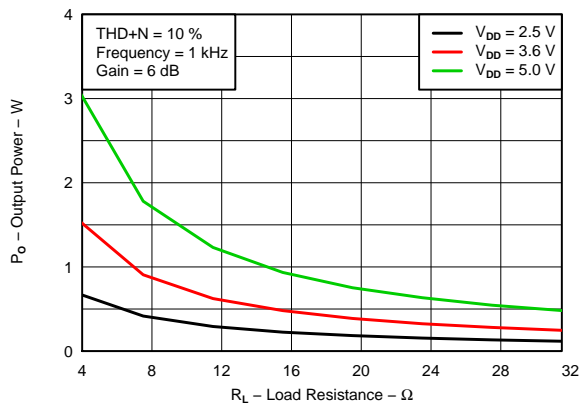

**Figure 9.**

**OUTPUT POWER vs LOAD RESISTANCE**

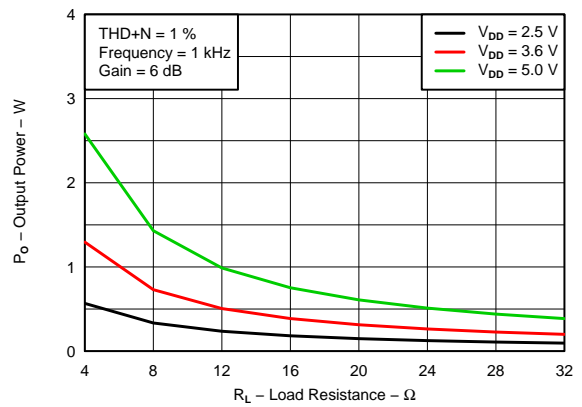

**Figure 10.**

**OUTPUT POWER vs SUPPLY VOLTAGE**

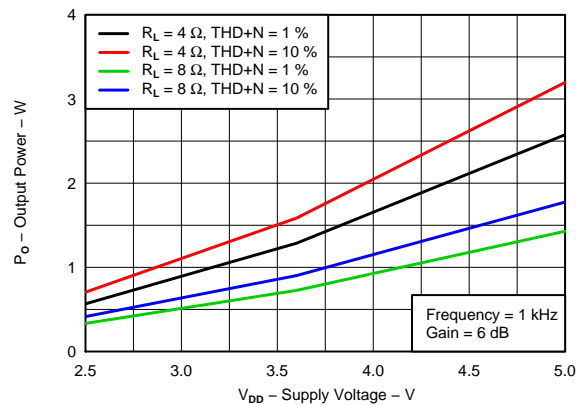

**Figure 11.**

**TYPICAL CHARACTERISTICS (continued)**

PVDD = VDD = 3.6 V, C<sub>I</sub> = 0.1 μF, C<sub>S1</sub> = 0.1 μF, C<sub>S2</sub> = 10 μF, T<sub>A</sub> = 25°C, R<sub>L</sub> = 8 Ω (unless otherwise noted)

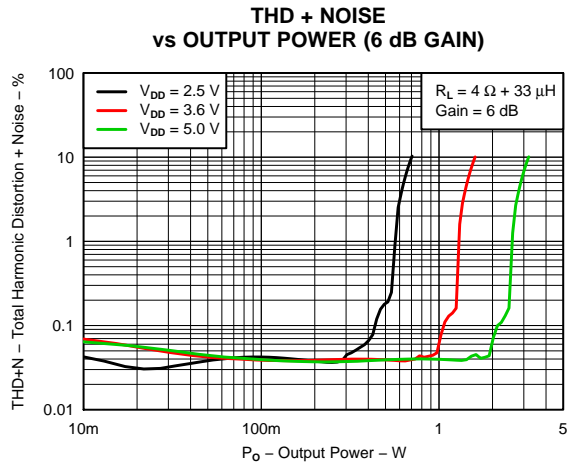

Figure 12.

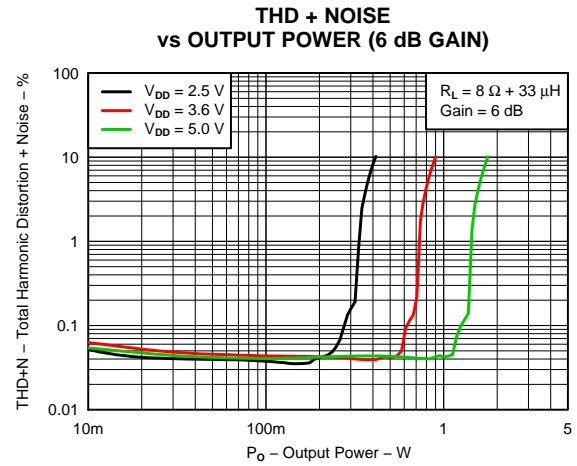

Figure 13.

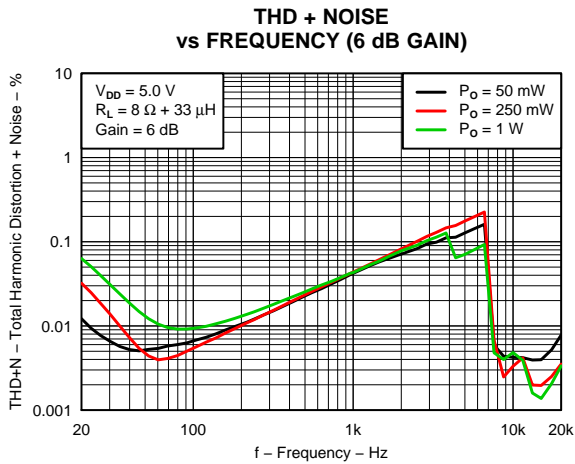

Figure 14.

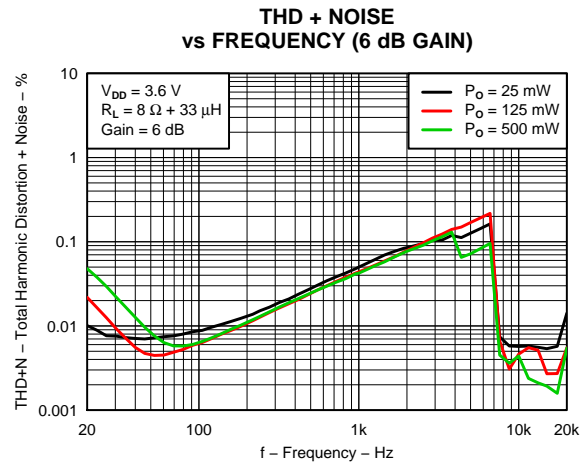

Figure 15.

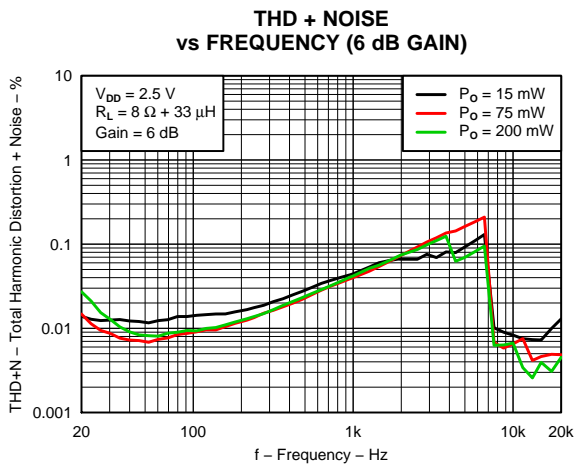

Figure 16.

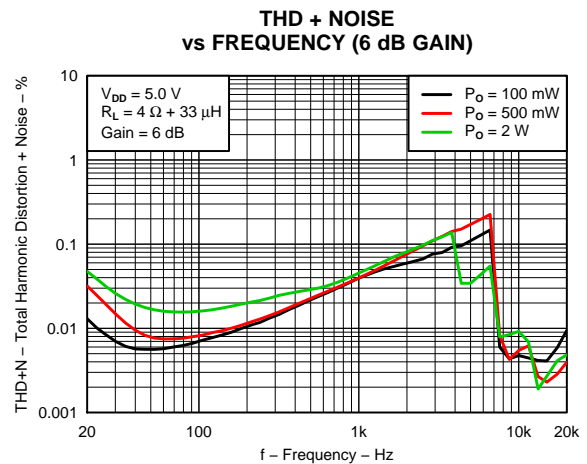

Figure 17.



**TYPICAL CHARACTERISTICS (continued)**

PVDD = VDD = 3.6 V, C<sub>I</sub> = 0.1 μF, C<sub>S1</sub> = 0.1 μF, C<sub>S2</sub> = 10 μF, T<sub>A</sub> = 25°C, R<sub>L</sub> = 8 Ω (unless otherwise noted)

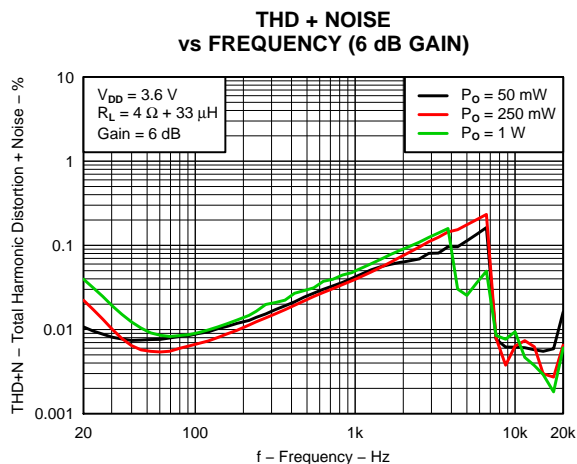

Figure 18.

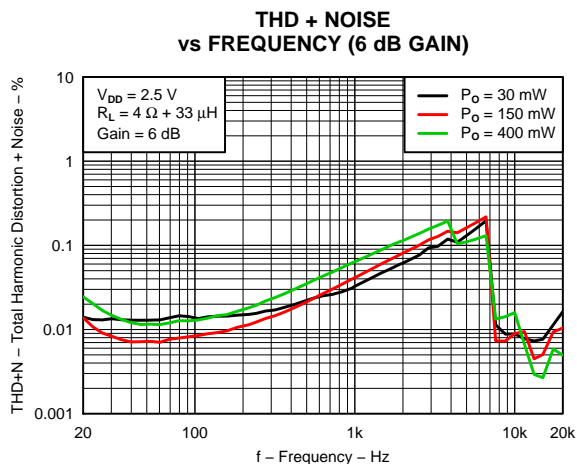

Figure 19.

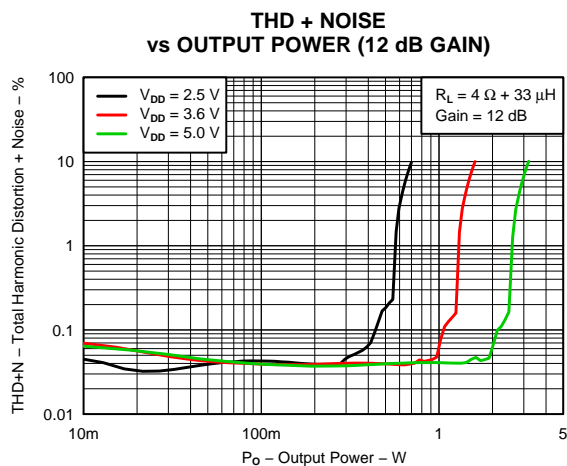

Figure 20.

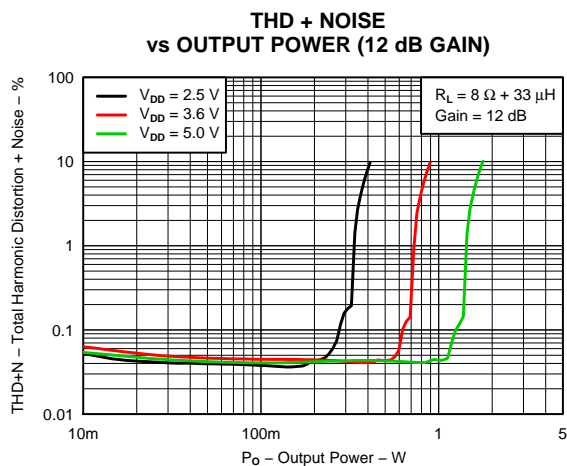

Figure 21.

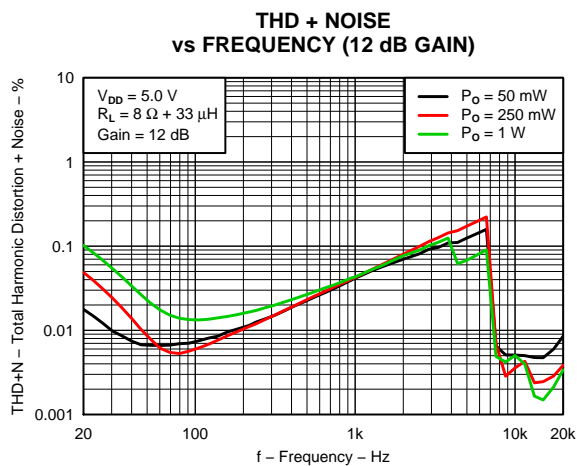

Figure 22.

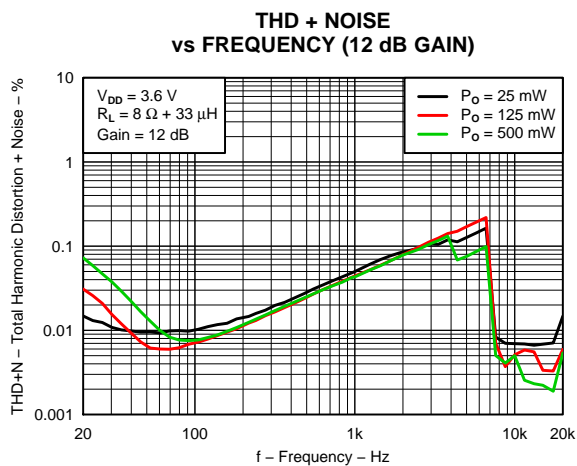

Figure 23.

**TYPICAL CHARACTERISTICS (continued)**

PVDD = VDD = 3.6 V, C<sub>I</sub> = 0.1 μF, C<sub>S1</sub> = 0.1 μF, C<sub>S2</sub> = 10 μF, T<sub>A</sub> = 25°C, R<sub>L</sub> = 8 Ω (unless otherwise noted)

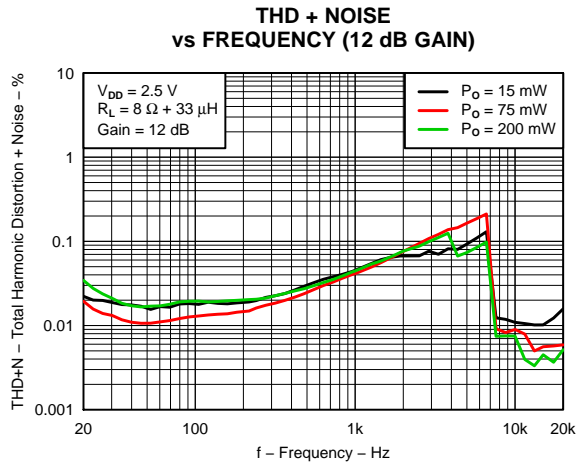

Figure 24.

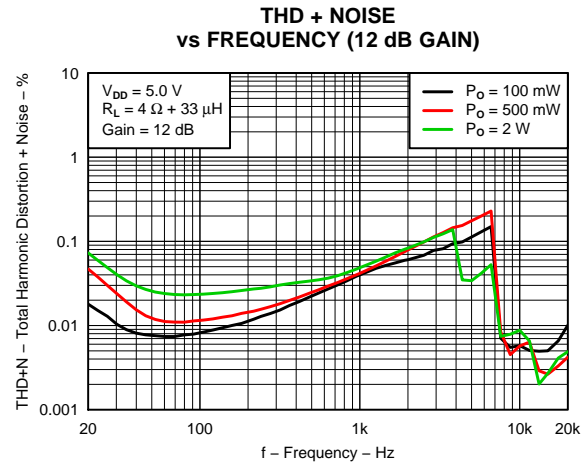

Figure 25.

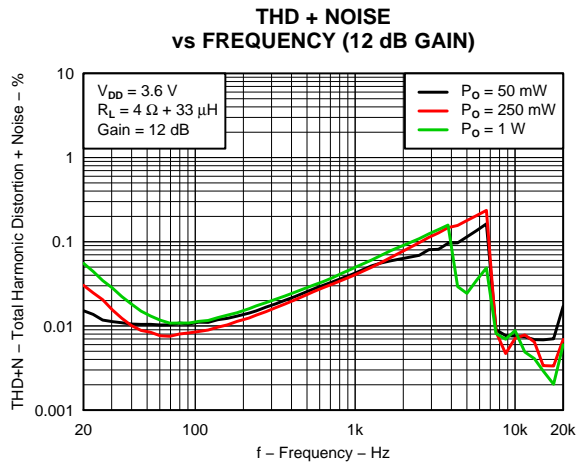

Figure 26.

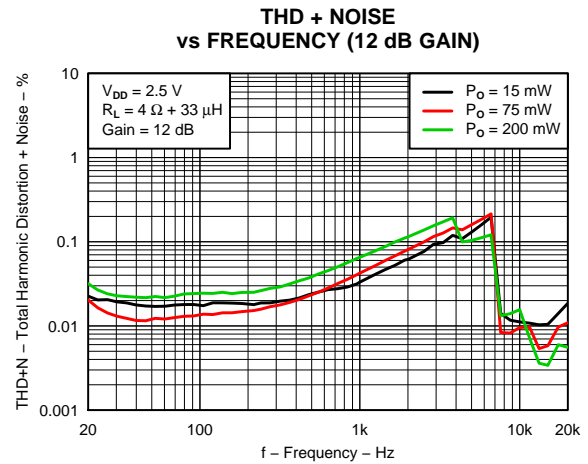

Figure 27.

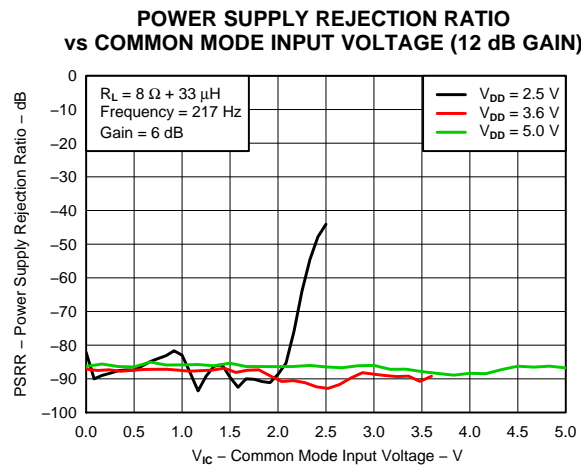

Figure 28.

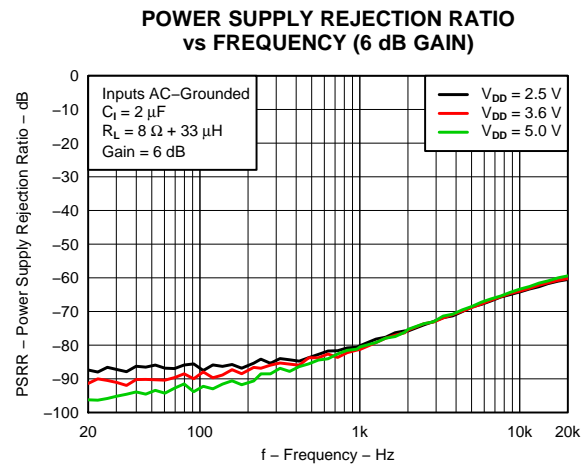

Figure 29.

**TYPICAL CHARACTERISTICS (continued)**

PVDD = VDD = 3.6 V, C<sub>I</sub> = 0.1 μF, C<sub>S1</sub> = 0.1 μF, C<sub>S2</sub> = 10 μF, T<sub>A</sub> = 25°C, R<sub>L</sub> = 8 Ω (unless otherwise noted)

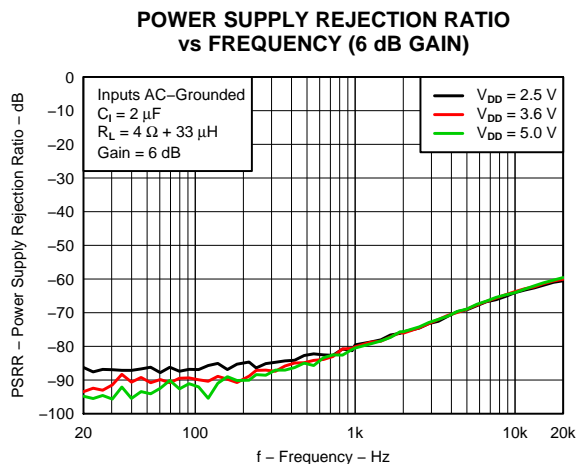

Figure 30.

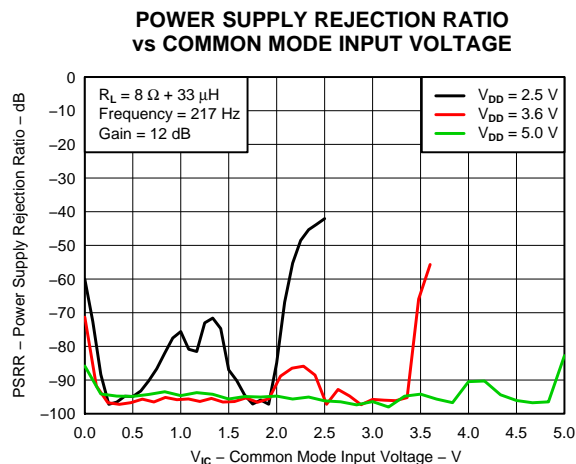

Figure 31.

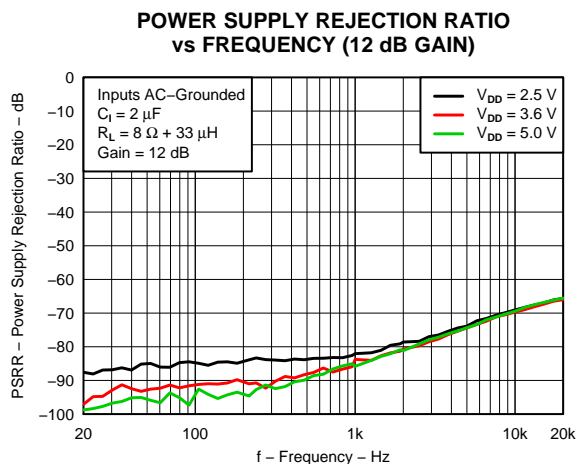

Figure 32.

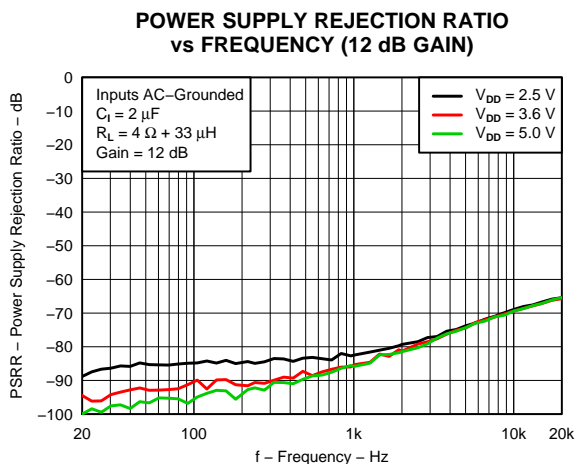

Figure 33.

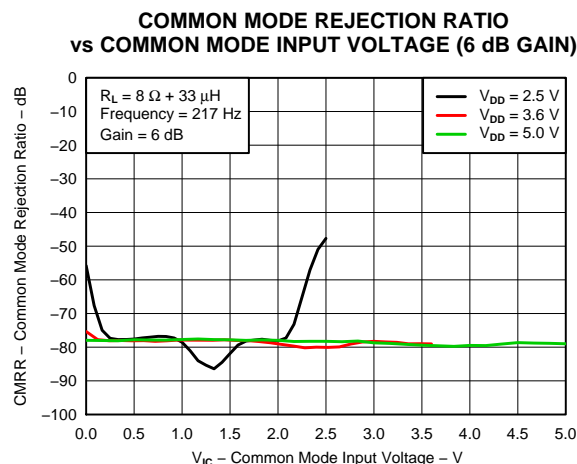

Figure 34.

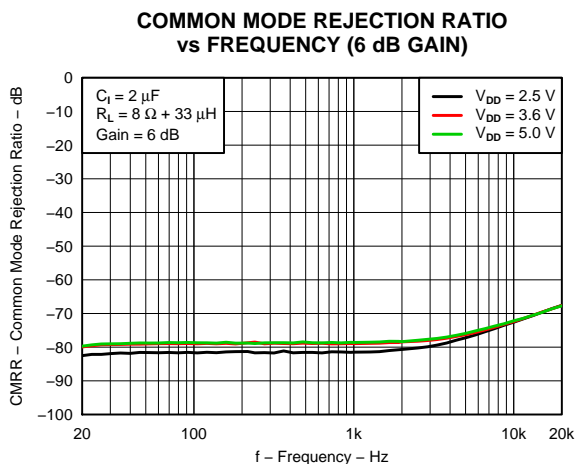

Figure 35.

**TYPICAL CHARACTERISTICS (continued)**

PVDD = VDD = 3.6 V, C<sub>I</sub> = 0.1 μF, C<sub>S1</sub> = 0.1 μF, C<sub>S2</sub> = 10 μF, T<sub>A</sub> = 25°C, R<sub>L</sub> = 8 Ω (unless otherwise noted)

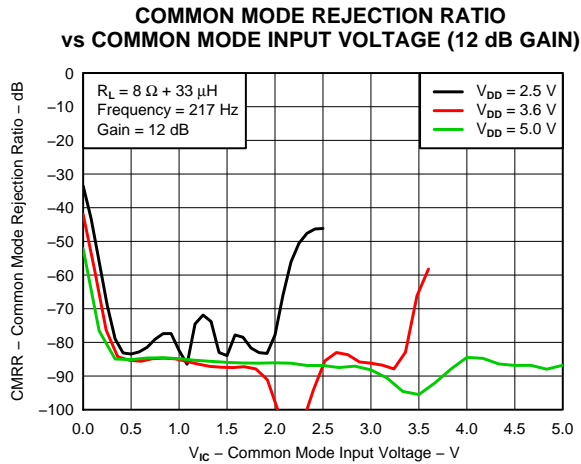

Figure 36.

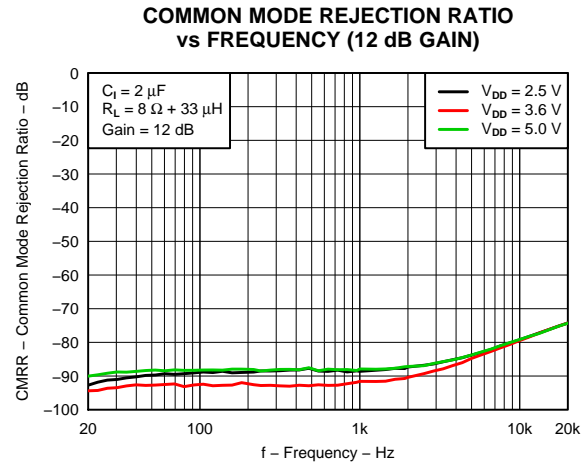

Figure 37.

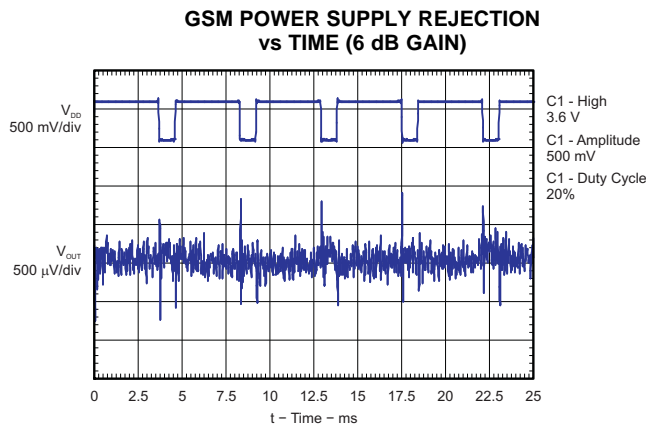

Figure 38.

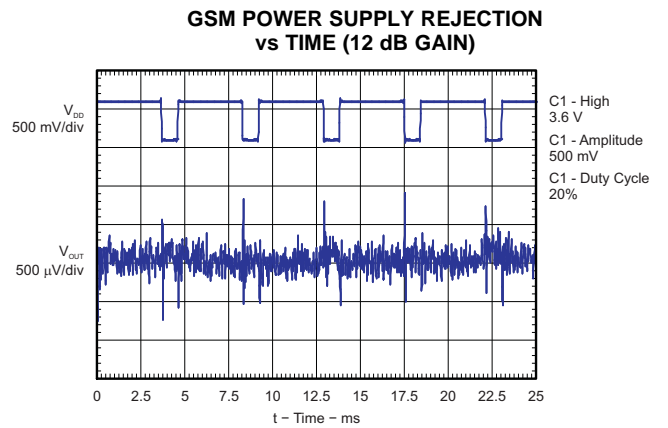

Figure 39.

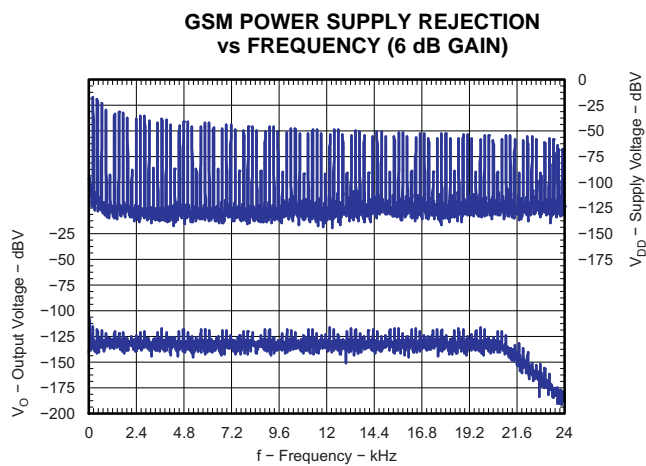

Figure 40.

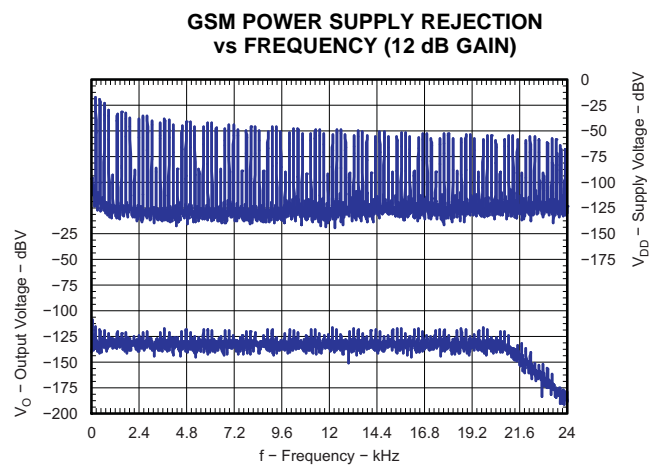

Figure 41.

## APPLICATION INFORMATION

### SHORT CIRCUIT AUTO-RECOVERY

When a short-circuit event occurs, the TPA2038D1 goes to shutdown mode and activates the integrated auto-recovery process whose aim is to return the device to normal operation once the short-circuit is removed. This process repeatedly examines (once every 100 ms) whether the short-circuit condition persists, and returns the device to normal operation immediately after the short-circuit condition is removed. This feature helps protect the device from large currents and maintain a good long-term reliability.

### INTEGRATED IMAGE REJECT FILTER FOR DAC NOISE REJECTION

In applications which use a DAC to drive Class-D amplifiers, out-of-band noise energy present at the DAC's image frequencies fold back into the audio-band at the output of the Class-D amplifier. An external low-pass filter is often placed between the DAC and the Class-D amplifier in order to attenuate this noise.

The TPA2038D1 has an integrated Image Reject Filter with a low-pass cutoff frequency of 130 kHz, which significantly attenuates this noise. Depending on the system noise specification, the integrated Image Reject Filter may help eliminate external filtering, thereby saving board space and component cost.

### COMPONENT SELECTION

Figure 42 shows the TPA2038D1 typical schematic with differential inputs, while Figure 43 shows the TPA2038D1 with differential inputs and input capacitors. Figure 44 shows the TPA2038D1 with a single-ended input.

#### Decoupling Capacitors ( $C_{S1}$ , $C_{S2}$ )

The TPA2038D1 is a high-performance class-D audio amplifier that requires adequate power supply decoupling to ensure the efficiency is high and total harmonic distortion (THD) is low. For higher frequency transients, spikes, or digital hash on the line, a good low equivalent-series-resistance (ESR) ceramic capacitor  $C_{S1} = 0.1 \mu\text{F}$ , placed as close as possible to the device  $V_{DD}$  lead works best. Placing  $C_{S1}$  close to the TPA2038D1 is important for the efficiency of the class-D amplifier, because any resistance or inductance in the trace between the device and the capacitor can cause a loss in efficiency. For filtering lower-frequency noise signals, a  $10 \mu\text{F}$  or greater capacitor ( $C_{S2}$ ) placed near the audio power amplifier would also help, but it is not required in most applications because of the high PSRR of this device. Typically, the smaller the capacitor's case size, the lower the inductance and the closer it can be placed to the TPA2038D1. X5R and X7R dielectric capacitors are recommended for both  $C_{S1}$  and  $C_{S2}$ .

#### Input Capacitors ( $C_I$ )

The TPA2038D1 does not require input coupling capacitors if the design uses a differential source that is biased within the common-mode input voltage range. That voltage range is listed in the Recommended Operating Conditions table. If the input signal is not biased within the recommended common-mode input range, such as in needing to use the input as a high pass filter, shown in Figure 43, or if using a single-ended source, shown in Figure 44, input coupling capacitors are required. The same value capacitors should be used on both IN+ and IN– for best pop performance. The 3 dB high-pass cutoff frequency  $f_C$  of the filter formed by the input coupling capacitor  $C_I$  and the input resistance  $R_I$  (typically  $150 \text{ k}\Omega$ ) of the TPA2038D1 is given by Equation 1:

$$f_C = \frac{1}{(2\pi R_I C_I)} \quad (1)$$

The value of the input capacitor is important to consider as it directly affects the bass (low frequency) performance of the circuit. Speaker response may also be taken into consideration when setting the corner frequency using input capacitors. Solving for the input coupling capacitance, we get:

$$C_I = \frac{1}{(2\pi R_I f_C)} \quad (2)$$

If the corner frequency is within the audio band, the capacitors should have a tolerance of  $\pm 10\%$  or better, because any mismatch in capacitance causes an impedance mismatch at the corner frequency and below.

# TPA2038D1

SLOS697 –AUGUST 2011

www.ti.com

For a flat low-frequency response, use large input coupling capacitors (0.1  $\mu\text{F}$  or larger). X5R and X7R dielectric capacitors are recommended.

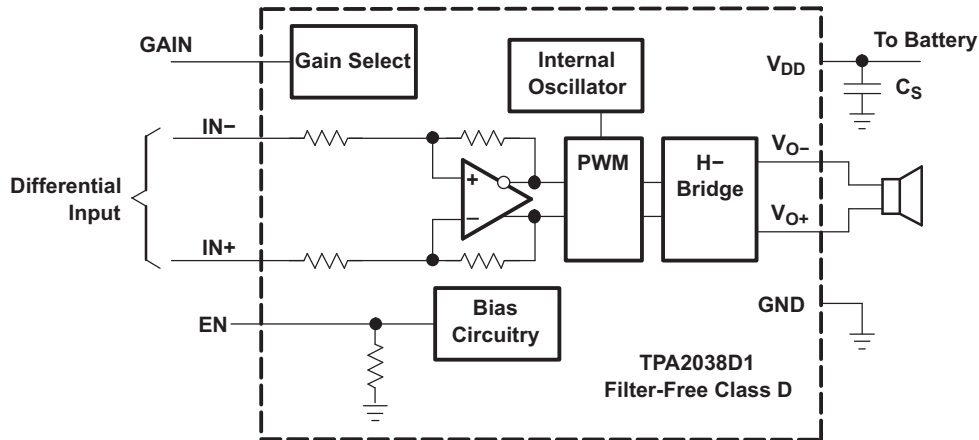

Figure 42. Typical TPA2038D1 Application Schematic With DC-coupled Differential Input

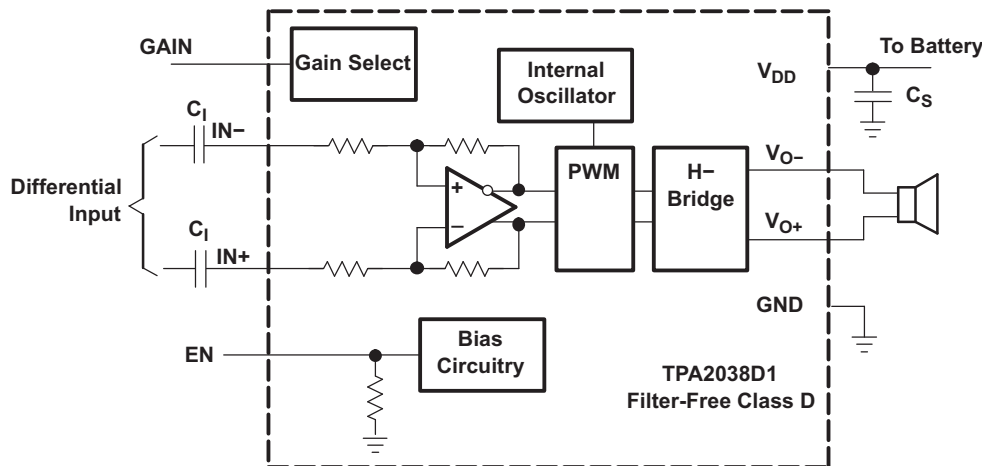

Figure 43. TPA2038D1 Application Schematic With Differential Input and Input Capacitors

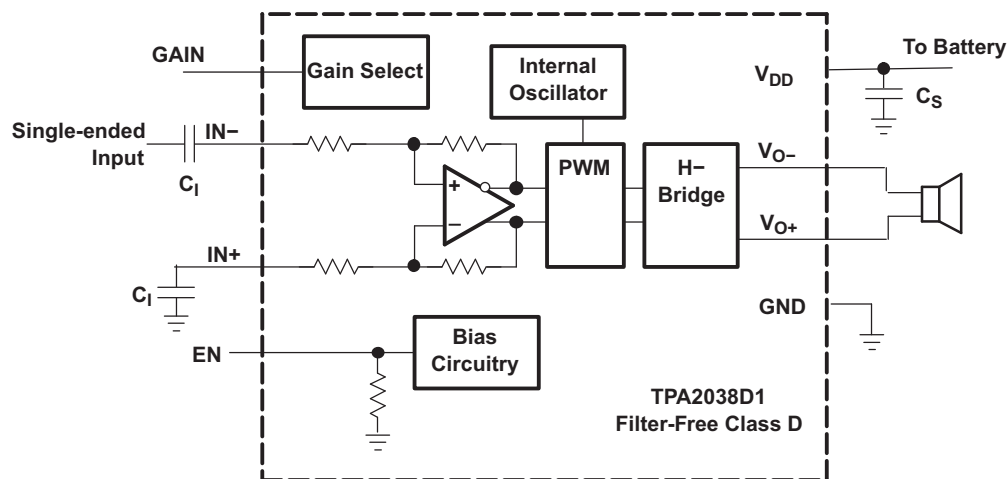

Figure 44. TPA2038D1 Application Schematic With Single-Ended Input

## EFFICIENCY AND THERMAL INFORMATION

The maximum ambient operating temperature of the TPA2038D1 depends on the load resistance, power supply voltage and heat-sinking ability of the PCB system. The derating factor for the YFF package is shown in the dissipation rating table. Converting this to  $\theta_{JA}$ :

$$\theta_{JA} = \frac{1}{\text{Derating Factor}} \quad (3)$$

Given  $\theta_{JA}$  (from the Package Dissipation ratings table), the maximum allowable junction temperature (from the Absolute Maximum ratings table), and the maximum internal dissipation (from Power Dissipation vs Output Power figures) the maximum ambient temperature can be calculated with the following equation. Note that the units on these figures are Watts RMS. Because audio contains crest factors (ratio of peak power to RMS power) from 9–15 dB, thermal limitations are not usually encountered.

$$T_{A\text{Max}} = T_{J\text{Max}} - \theta_{JA} P_{D\text{max}} \quad (4)$$

The TPA2038D1 is designed with thermal protection that turns the device off when the junction temperature surpasses 150°C to prevent damage to the IC. Note that the use of speakers less resistive than 4  $\Omega$  (typ) is not advisable. Below 4  $\Omega$  (typ) the thermal performance of the device dramatically reduces because of increased output current and reduced amplifier efficiency. The Absolute Maximum rating of 3.2  $\Omega$  covers the manufacturing tolerance of a 4  $\Omega$  speaker and speaker impedance decrease due to frequency.  $\theta_{JA}$  is a gross approximation of the complex thermal transfer mechanisms between the device and its ambient environment. If the  $\theta_{JA}$  calculation reveals a potential problem, a more accurate estimate should be made.

## WHEN TO USE AN OUTPUT FILTER

Design the TPA2038D1 without an Inductor / Capacitor (LC) output filter if the traces from the amplifier to the speaker are short. Wireless handsets and PDAs are great applications for this class-D amplifier to be used without an output filter.

The TPA2038D1 does not require an LC output filter for short speaker connections (approximately 100 mm long or less). A ferrite bead can often be used in the design if failing radiated emissions testing without an LC filter; and, the frequency-sensitive circuit is greater than 1 MHz. If choosing a ferrite bead, choose one with high impedance at high frequencies, but very low impedance at low frequencies. The selection must also take into account the currents flowing through the ferrite bead. Ferrites can begin to lose effectiveness at much lower than rated current values. See the EVM User's Guide (SLOU298) for components used successfully by TI.

Figure 45 shows a typical ferrite-bead output filter.

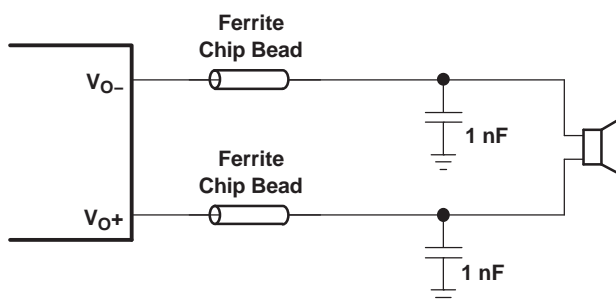

**Figure 45. Typical Ferrite Chip Bead Filter**

**PRINTED CIRCUIT BOARD LAYOUT**

In making the pad size for the WCSP balls, it is recommended that the layout use non-solder-mask-defined (NSMD) land. With this method, the solder mask opening is made larger than the desired land area, and the opening size is defined by the copper pad width. Figure 46 shows the appropriate diameters for a WCSP layout.

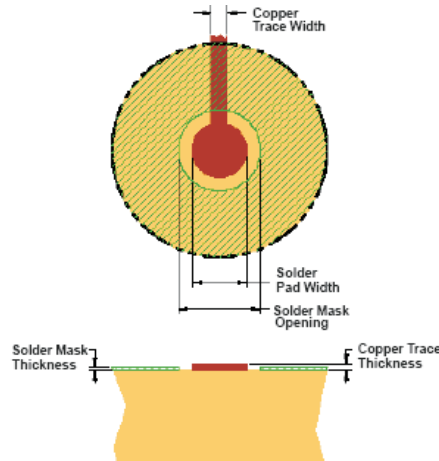

**Figure 46. Land Pattern Image and Dimensions**

| SOLDER PAD DEFINITIONS         | COPPER PAD | SOLDER MASK OPENING <sup>(5)</sup> | COPPER THICKNESS    | STENCIL OPENING <sup>(6)(7)</sup>         | STENCIL THICKNESS |
|--------------------------------|------------|------------------------------------|---------------------|---|-------------------|
| Non-solder-mask-defined (NSMD) | 0.23 mm    | 0.310 mm                           | 1 oz max (0.032 mm) | 0.275 mm x 0.275 mm Sq. (rounded corners) | 0.1 mm thick      |

1. Circuit traces from NSMD defined PWB lands should be 75 µm to 100 µm wide in the exposed area inside the solder mask opening. Wider trace widths reduce device stand off and impact reliability.
2. Best reliability results are achieved when the PWB laminate glass transition temperature is above the operating the range of the intended application.
3. Recommend solder paste is Type 3 or Type 4.
4. For a PWB using a Ni/Au surface finish, the gold thickness should be less 0.5 µm to avoid a reduction in thermal fatigue performance.
5. Solder mask thickness should be less than 20 µm on top of the copper circuit pattern
6. Best solder stencil performance is achieved using laser cut stencils with electro polishing. Use of chemically etched stencils give inferior solder paste volume control.
7. Trace routing away from WCSP device should be balanced in X and Y directions to avoid unintentional component movement due to solder wetting forces.

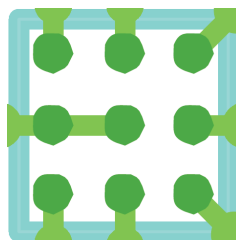

**Figure 47. Layout Snapshot**

An on-pad via is not required to route the middle ball B2 (PV<sub>DD</sub>) of the TPA2038D1. Short ball B2 (PV<sub>DD</sub>) to ball B1 (V<sub>DD</sub>) and connect both to the supply trace as shown in Figure 47. This simplifies board routing and saves manufacturing cost.



**PACKAGE DIMENSIONS**

| <b>D</b>           | <b>E</b>           |
|--------------------|--------------------|
| Max = 1244 $\mu$ m | Max = 1190 $\mu$ m |
| Min = 1184 $\mu$ m | Min = 1130 $\mu$ m |

**PACKAGING INFORMATION**

| Orderable Device | Status <sup>(1)</sup> | Package Type | Package Drawing | Pins | Package Qty | Eco Plan <sup>(2)</sup> | Lead/Ball Finish | MSL Peak Temp <sup>(3)</sup> | Samples<br>(Requires Login) |
|------------------|-----------------------|--------------|-----------------|------|-------------|-------------------------|------------------|------------------------------|-----------------------------|
| TPA2038D1YFFR    | ACTIVE                | DSBGA        | YFF             | 9    | 3000        | Green (RoHS & no Sb/Br) | SNAGCU           | Level-1-260C-UNLIM           |                             |
| TPA2038D1YFFT    | ACTIVE                | DSBGA        | YFF             | 9    | 250         | Green (RoHS & no Sb/Br) | SNAGCU           | Level-1-260C-UNLIM           |                             |

<sup>(1)</sup> The marketing status values are defined as follows:

**ACTIVE:** Product device recommended for new designs.

**LIFEBUY:** TI has announced that the device will be discontinued, and a lifetime-buy period is in effect.

**NRND:** Not recommended for new designs. Device is in production to support existing customers, but TI does not recommend using this part in a new design.

**PREVIEW:** Device has been announced but is not in production. Samples may or may not be available.

**OBsolete:** TI has discontinued the production of the device.

<sup>(2)</sup> Eco Plan - The planned eco-friendly classification: Pb-Free (RoHS), Pb-Free (RoHS Exempt), or Green (RoHS & no Sb/Br) - please check <http://www.ti.com/productcontent> for the latest availability information and additional product content details.

**TBD:** The Pb-Free/Green conversion plan has not been defined.

**Pb-Free (RoHS):** TI's terms "Lead-Free" or "Pb-Free" mean semiconductor products that are compatible with the current RoHS requirements for all 6 substances, including the requirement that lead not exceed 0.1% by weight in homogeneous materials. Where designed to be soldered at high temperatures, TI Pb-Free products are suitable for use in specified lead-free processes.

**Pb-Free (RoHS Exempt):** This component has a RoHS exemption for either 1) lead-based flip-chip solder bumps used between the die and package, or 2) lead-based die adhesive used between the die and leadframe. The component is otherwise considered Pb-Free (RoHS compatible) as defined above.

**Green (RoHS & no Sb/Br):** TI defines "Green" to mean Pb-Free (RoHS compatible), and free of Bromine (Br) and Antimony (Sb) based flame retardants (Br or Sb do not exceed 0.1% by weight in homogeneous material)

<sup>(3)</sup> MSL, Peak Temp. -- The Moisture Sensitivity Level rating according to the JEDEC industry standard classifications, and peak solder temperature.

**Important Information and Disclaimer:** The information provided on this page represents TI's knowledge and belief as of the date that it is provided. TI bases its knowledge and belief on information provided by third parties, and makes no representation or warranty as to the accuracy of such information. Efforts are underway to better integrate information from third parties. TI has taken and continues to take reasonable steps to provide representative and accurate information but may not have conducted destructive testing or chemical analysis on incoming materials and chemicals. TI and TI suppliers consider certain information to be proprietary, and thus CAS numbers and other limited information may not be available for release.

In no event shall TI's liability arising out of such information exceed the total purchase price of the TI part(s) at issue in this document sold by TI to Customer on an annual basis.

**TAPE AND REEL INFORMATION**
**REEL DIMENSIONS**

**TAPE DIMENSIONS**

|    |   |
|----|---|
| A0 | Dimension designed to accommodate the component width     |
| B0 | Dimension designed to accommodate the component length    |
| K0 | Dimension designed to accommodate the component thickness |
| W  | Overall width of the carrier tape                         |
| P1 | Pitch between successive cavity centers                   |

**TAPE AND REEL INFORMATION**

\*All dimensions are nominal

| Device        | Package Type | Package Drawing | Pins | SPQ | Reel Diameter (mm) | Reel Width W1 (mm) | A0 (mm) | B0 (mm) | K0 (mm) | P1 (mm) | W (mm) | Pin1 Quadrant |
|---------------|--------------|-----------------|------|-----|--------------------|--------------------|---------|---------|---------|---------|--------|---------------|
| TPA2038D1YFFT | DSBGA        | YFF             | 9    | 250 | 180.0              | 8.4                | 1.34    | 1.34    | 0.81    | 4.0     | 8.0    | Q1            |

**TAPE AND REEL BOX DIMENSIONS**



\*All dimensions are nominal

| Device        | Package Type | Package Drawing | Pins | SPQ | Length (mm) | Width (mm) | Height (mm) |
|---------------|--------------|-----------------|------|-----|-------------|------------|-------------|
| TPA2038D1YFFT | DSBGA        | YFF             | 9    | 250 | 210.0       | 185.0      | 35.0        |

YFF (S-XBGA-N9)

DIE-SIZE BALL GRID ARRAY

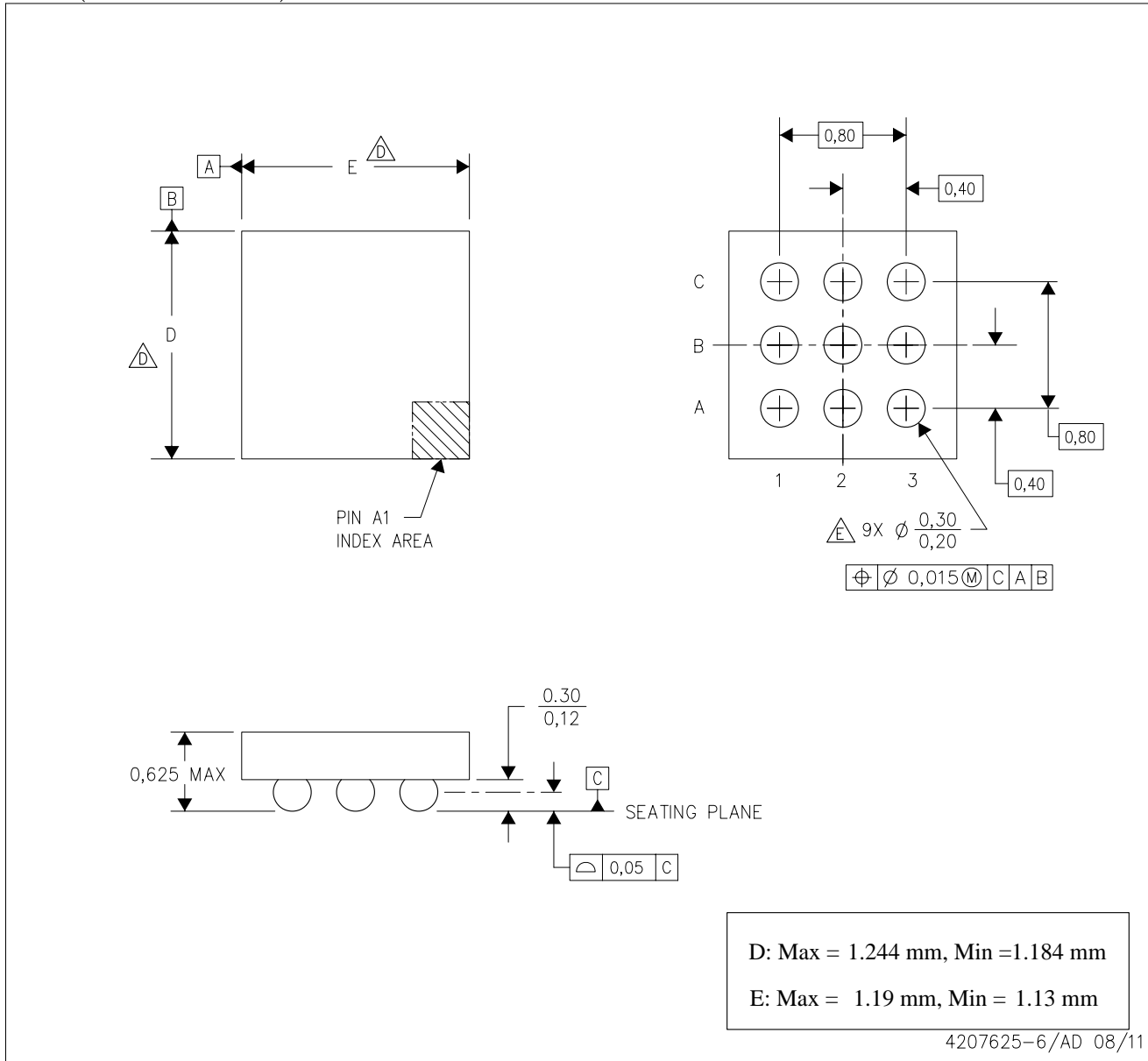

- NOTES:
- A. All linear dimensions are in millimeters. Dimensioning and tolerancing per ASME Y14.5M-1994.
  - B. This drawing is subject to change without notice.
  - C. NanoFree™ package configuration.
  - $\triangle$  The package size (Dimension D and E) of a particular device is specified in the device Product Data Sheet version of this drawing, in case it cannot be found in the product data sheet please contact a local TI representative.
  - E. Reference Product Data Sheet for array population.  
3 x 3 matrix pattern is shown for illustration only.
  - F. This package contains Pb-free balls.

## **IMPORTANT NOTICE**

Texas Instruments and its subsidiaries (TI) reserve the right to make changes to their products or to discontinue any product or service without notice, and advise customers to obtain the latest version of relevant information to verify, before placing orders, that information being relied on is current and complete. All products are sold subject to the terms and conditions of sale supplied at the time of order acknowledgement, including those pertaining to warranty, patent infringement, and limitation of liability.

TI warrants performance of its semiconductor products to the specifications applicable at the time of sale in accordance with TI's standard warranty. Testing and other quality control techniques are utilized to the extent TI deems necessary to support this warranty. Specific testing of all parameters of each device is not necessarily performed, except those mandated by government requirements.

**CERTAIN APPLICATIONS USING SEMICONDUCTOR PRODUCTS MAY INVOLVE POTENTIAL RISKS OF DEATH, PERSONAL INJURY, OR SEVERE PROPERTY OR ENVIRONMENTAL DAMAGE ("CRITICAL APPLICATIONS"). TI SEMICONDUCTOR PRODUCTS ARE NOT DESIGNED, AUTHORIZED, OR WARRANTED TO BE SUITABLE FOR USE IN LIFE-SUPPORT DEVICES OR SYSTEMS OR OTHER CRITICAL APPLICATIONS. INCLUSION OF TI PRODUCTS IN SUCH APPLICATIONS IS UNDERSTOOD TO BE FULLY AT THE CUSTOMER'S RISK.**

In order to minimize risks associated with the customer's applications, adequate design and operating safeguards must be provided by the customer to minimize inherent or procedural hazards.

TI assumes no liability for applications assistance or customer product design. TI does not warrant or represent that any license, either express or implied, is granted under any patent right, copyright, mask work right, or other intellectual property right of TI covering or relating to any combination, machine, or process in which such semiconductor products or services might be or are used. TI's publication of information regarding any third party's products or services does not constitute TI's approval, warranty or endorsement thereof.