

# TMUX154E ESD-Protected, Low Capacitance, 2-Channel, 2:1 Switch, With Powered-off Protection

## 1 Features

- $V_{CC}$  Operation at 3 V to 4.3 V
- I/O Pins Can Tolerate up to 5.25 V
- 1.8-V Compatible Control Logic
- Supports Powered-off Protection I/O Pins Hi-Z When  $V_{CC} = 0$  V
- $R_{ON} = 10 \Omega$  Maximum
- $\Delta R_{ON} = 0.35 \Omega$  Typical
- $C_{io(ON)} = 7.5$  pF Typical
- Low Power Consumption (1  $\mu$ A Maximum)
- $-3$ -dB Bandwidth = 900 MHz Typical
- Latch-Up Performance Exceeds 100 mA Per JESD 78, Class II <sup>(1)</sup>
- ESD Performance Tested Per JESD 22
  - 8000-V Human-Body Model (A114-B, Class II)
  - 1000-V Charged-Device Model (C101)
- ESD Performance I/O Port to GND <sup>(2)</sup>
  - 15000-V Human-Body Model

(1) Except  $\overline{EN}$  and SEL Inputs

(2) High-voltage HBM is performed in addition to the standard HBM testing (A114-B, Class II) and applies to I/O ports tested with respect to GND only.

## 2 Applications

- Portable Electronics
- Printers and other Peripherals
- Electronic Point of Sale
- Building Automation
- Servers

## 3 Description

The TMUX154E is a high-bandwidth 2:1 switch specially designed for the switching of high-speed signals in applications with limited I/Os. The wide bandwidth (900 MHz) of this switch allows signals to pass with minimum edge and phase distortion. The switch is bidirectional and offers little or no attenuation of high-speed signals. It is designed for low bit-to-bit skew and high channel-to-channel noise isolation.

The TMUX154E integrates ESD protection cells on all pins, is available in a tiny UQFN package (1.8 mm  $\times$  1.4 mm) or a VSSOP package, and is characterized over the free-air temperature range of  $-40^{\circ}\text{C}$  to  $85^{\circ}\text{C}$ .

### Device Information<sup>(1)</sup>

PART NUMBER	PACKAGE	BODY SIZE (NOM)
TMUX154E	VSSOP (10)	3.00 mm $\times$ 3.00 mm
	UQFN (10)	1.80 mm $\times$ 1.40 mm

(1) For all available packages, see the orderable addendum at the end of the datasheet.

### Functional Block Diagram

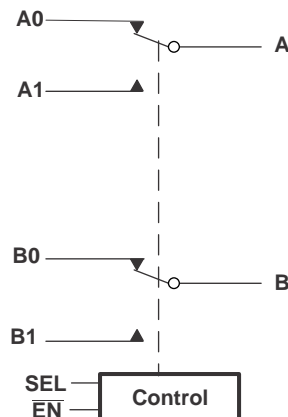

Copyright © 2018, Texas Instruments Incorporated



## Table of Contents

<b>1 Features</b> ..... 1 <b>2 Applications</b> ..... 1 <b>3 Description</b> ..... 1 <b>4 Revision History</b> ..... 2 <b>5 Pin Configuration and Functions</b> ..... 3 <b>6 Specifications</b> ..... 4 6.1 Absolute Maximum Ratings ..... 4 6.2 ESD Ratings..... 4 6.3 Recommended Operating Conditions ..... 4 6.4 Thermal Information ..... 5 6.5 Electrical Characteristics ..... 5 6.6 Dynamic Electrical Characteristics..... 6 6.7 Switching Characteristics ..... 6 6.8 Typical Characteristics ..... 7 <b>7 Parameter Measurement Information</b> ..... 8 <b>8 Detailed Description</b> ..... 12 8.1 Overview ..... 12 8.2 Functional Block Diagram ..... 12	8.3 Feature Description..... 12 8.4 Device Functional Modes..... 12 <b>9 Application and Implementation</b> ..... 13 9.1 Application Information..... 13 9.2 Typical Application ..... 13 <b>10 Power Supply Recommendations</b> ..... 15 <b>11 Layout</b> ..... 15 11.1 Layout Guidelines ..... 15 11.2 Layout Example ..... 16 <b>12 Device and Documentation Support</b> ..... 17 12.1 Documentation Support ..... 17 12.2 Receiving Notification of Documentation Updates 17 12.3 Community Resources..... 17 12.4 Trademarks ..... 17 12.5 Electrostatic Discharge Caution..... 17 12.6 Glossary ..... 17 <b>13 Mechanical, Packaging, and Orderable Information</b> ..... 18
--	--

## 4 Revision History

NOTE: Page numbers for previous revisions may differ from page numbers in the current version.

DATE	REVISION	NOTES
February 2018	*	Initial release.

## 5 Pin Configuration and Functions

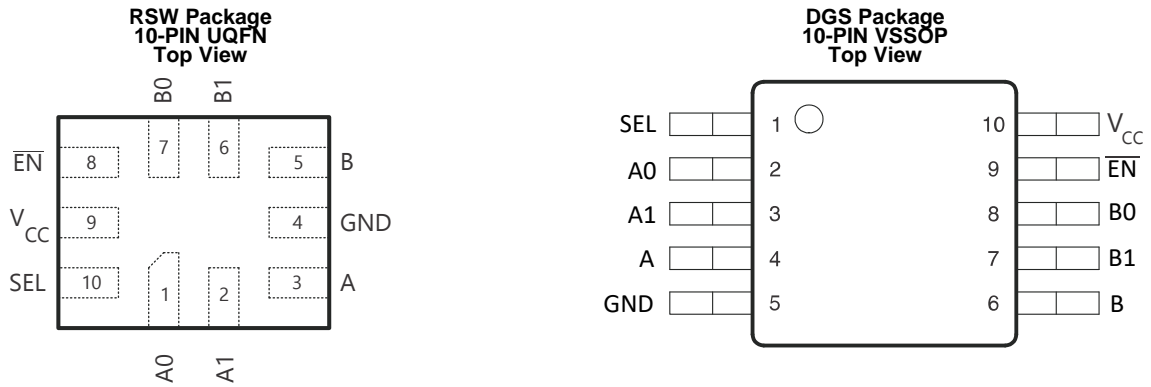

### Pin Functions

NAME	PIN		I/O	DESCRIPTION
	UQFN	VSSOP		
A0	1	2	I/O	signal path port 0
B0	7	8	I/O	
A	3	4	I/O	Common signal path
B	5	6	I/O	
A1	2	3	I/O	signal path port 1
B1	6	7	I/O	
$\overline{\text{EN}}$	8	9	I	EN = 0 Enable EN = 1 Disable
SEL	10	1	I	Select input: SEL = 0 A,B to A0,B0 SEL = 1 A,B to A1,B1
GND	4	5	—	Ground
VCC	9	10	—	Voltage supply

## 6 Specifications

### 6.1 Absolute Maximum Ratings

over operating free-air temperature range (unless otherwise noted) (see <sup>(1)</sup> <sup>(2)</sup>)

		MIN	MAX	UNIT
$V_{CC}$	Supply voltage	-0.5	7	V
$V_{SEL}, \overline{V_{EN}}$	Control input voltage	-0.5	7	V
$V_{I/O}$	Signal path I/O voltage	$V_{CC} > 0$	$V_{CC} + 0.3$	V
		$V_{CC} = 0$	5.25	
$I_{IK}$	Control input clamp current	$V_{IN} < 0$	-50	mA
$I_{I/OK}$	I/O port clamp current	$V_{I/O} < 0$	-50	mA
$I_{I/O}$	ON-state switch current		±64	mA
	Continuous current through $V_{CC}$ or GND		±100	mA
$T_{stg}$	Storage temperature	-65	150	°C

- (1) Stresses beyond those listed under *Absolute Maximum Ratings* may cause permanent damage to the device. These are stress ratings only, which do not imply functional operation of the device at these or any other conditions beyond those indicated under *Recommended Operating Conditions*. Exposure to absolute-maximum-rated conditions for extended periods may affect device reliability.
- (2) All voltages are with respect to ground, unless otherwise specified.

### 6.2 ESD Ratings

			VALUE	UNIT
$V_{(ESD)}$	Electrostatic discharge	Human body model (HBM), per ANSI/ESDA/JEDEC JS-001 <sup>(1)</sup>	All pins	±8000
			I/O port to GND	±15000
		Charged-device model (CDM), per JEDEC specification JESD22-C101 <sup>(2)</sup>		±1000

- (1) JEDEC document JEP155 states that 500-V HBM allows safe manufacturing with a standard ESD control process.
- (2) JEDEC document JEP157 states that 250-V CDM allows safe manufacturing with a standard ESD control process.

### 6.3 Recommended Operating Conditions

See <sup>(1)</sup>.

		MIN	MAX	UNIT
$V_{CC}$	Supply voltage	3	4.3	V
$V_{IH}$	High-level control input voltage	$V_{CC} = 3\text{ V to }3.6\text{ V}$	1.3	$V_{CC}$
		$V_{CC} = 4.3\text{ V}$	1.7	$V_{CC}$
$V_{IL}$	Low-level control input voltage	$V_{CC} = 3\text{ V to }3.6\text{ V}$	0	0.5
		$V_{CC} = 4.3\text{ V}$	0	0.7
$V_{I/O}$	Data input/output voltage	0	$V_{CC}$	V
$T_A$	Operating ambient temperature	-40	85	°C

- (1) All unused control inputs of the device must be held at  $V_{CC}$  or GND to ensure proper device operation. Refer to *Implications of Slow or Floating CMOS Inputs* (SCBA004).

## 6.4 Thermal Information

THERMAL METRIC <sup>(1)</sup>		TMUX154E		UNIT
		DGS (VSSOP)	RSW (UQFN)	
		10 PINS	10 PINS	
R <sub>θJA</sub>	Junction-to-ambient thermal resistance	203.1	114.5	°C/W
R <sub>θJC(top)</sub>	Junction-to-case (top) thermal resistance	88.7	64.7	°C/W
R <sub>θJB</sub>	Junction-to-board thermal resistance	123.0	21.0	°C/W
ψ <sub>JT</sub>	Junction-to-top characterization parameter	21.2	1.9	°C/W
ψ <sub>JB</sub>	Junction-to-board characterization parameter	121.6	21.0	°C/W

(1) For more information about traditional and new thermal metrics, see the [Semiconductor and IC Package Thermal Metrics](#) application report.

## 6.5 Electrical Characteristics

over operating free-air temperature range (unless otherwise noted)<sup>(1)</sup>

PARAMETER		TEST CONDITIONS	MIN	TYP <sup>(2)</sup>	MAX	UNIT
I <sub>SEL</sub> , I <sub>EN</sub>	Control inputs	V <sub>CC</sub> = 4.3 V, 0 V, V <sub>SEL</sub> , V <sub>EN</sub> = 0 to 4.3 V			±1	μA
I <sub>OZ</sub>	OFF-state leakage current <sup>(3)</sup>	V <sub>CC</sub> = 4.3 V, V <sub>O</sub> = 0 to 3.6 V, V <sub>I</sub> = 0, Switch OFF			±1	μA
I <sub>OFF</sub>	Powered off leakage current	V <sub>CC</sub> = 0 V, V <sub>An,Bn</sub> = 0 V, V <sub>A,B</sub> = 0 V to 4.3 V, V <sub>SEL</sub> , V <sub>EN</sub> = V <sub>CC</sub> or GND			±2	μA
I <sub>CC</sub>	Supply current	V <sub>CC</sub> = 4.3 V, I <sub>I/O</sub> = 0, Switch ON or OFF			1	μA
ΔI <sub>CC</sub> <sup>(4)</sup>	Difference of supply current due to control input voltage not V <sub>CC</sub> or GND	V <sub>CC</sub> = 4.3 V, V <sub>SEL</sub> , V <sub>EN</sub> = 2.6 V			10	μA
C <sub>SEL</sub> , C <sub>EN</sub>	Control inputs digital input capacitance	V <sub>CC</sub> = 0 V, V <sub>SEL</sub> , V <sub>EN</sub> = V <sub>CC</sub> or GND		1		pF
C <sub>I/O(OFF)</sub>	OFF-state input capacitance	V <sub>CC</sub> = 3.3 V, V <sub>I/O</sub> = 3.3 V or 0, Switch OFF		2		pF
C <sub>I/O(ON)</sub>	ON-state input capacitance	V <sub>CC</sub> = 3.3 V, V <sub>I/O</sub> = 3.3 V or 0, Switch ON		7.5		pF
R <sub>ON</sub>	ON-state resistance <sup>(5)</sup>	V <sub>CC</sub> = 3 V, V <sub>I</sub> = 0.4, I <sub>O</sub> = –8 mA		6	10	Ω
ΔR <sub>ON</sub>	ON-state resistance match between channels	V <sub>CC</sub> = 3 V, V <sub>I</sub> = 0.4, I <sub>O</sub> = –8 mA		0.35		Ω
r <sub>on(flat)</sub>	ON-state resistance flatness	V <sub>CC</sub> = 3 V, V <sub>I</sub> = 0 V or 1 V, I <sub>O</sub> = –8 mA		2		Ω

(1) V<sub>I</sub>, V<sub>O</sub>, I<sub>I</sub>, and I<sub>O</sub> refer to data I/O pins A, B, An, and Bn.

(2) All typical values are at V<sub>CC</sub> = 3.3 V (unless otherwise noted), T<sub>A</sub> = 25°C.

(3) For I/O ports, the parameter I<sub>OZ</sub> includes the input leakage current.

(4) This is the increase in supply current for each digital control input that is supplied with a voltage other than V<sub>CC</sub> or GND.

(5) Measured by the voltage drop between the A and B terminals at the indicated current through the switch. ON-state resistance is determined by the lower of the voltages of the two (A or B) terminals.

## 6.6 Dynamic Electrical Characteristics

 over operating range,  $T_A = -40^{\circ}\text{C}$  to  $85^{\circ}\text{C}$ ,  $V_{CC} = 3.3\text{ V} \pm 10\%$ ,  $\text{GND} = 0\text{ V}$ 

PARAMETER		TEST CONDITIONS	TYP <sup>(1)</sup>	UNIT
X <sub>TALK</sub>	Crosstalk	$R_L = 50\ \Omega$ , $f = 1\ \text{MHz}$ , See <a href="#">Figure 6</a>	-97	dB
O <sub>ISO</sub>	OFF isolation	$R_L = 50\ \Omega$ , $f = 1\ \text{MHz}$ , See <a href="#">Figure 5</a>	-85	dB
BW	Bandwidth (-3 dB)	$R_L = 50\ \Omega$ , $C_L = 5\ \text{pF}$ , See <a href="#">Figure 7</a>	900	MHz

 (1) For Max or Min conditions, use the appropriate value specified under [Electrical Characteristics](#) for the applicable device type.

## 6.7 Switching Characteristics

 over operating range,  $T_A = -40^{\circ}\text{C}$  to  $85^{\circ}\text{C}$ ,  $V_{CC} = 3.3\text{ V} \pm 10\%$ ,  $\text{GND} = 0\text{ V}$ 

PARAMETER		TEST CONDITIONS	MIN	TYP <sup>(1)</sup>	MAX	UNIT
t <sub>pd</sub>	Propagation delay <sup>(2)</sup> <sup>(3)</sup>	$R_L = 50\ \Omega$ , $C_L = 5\ \text{pF}$ , See <a href="#">Figure 8</a>		0.25		ns
t <sub>ON</sub>	Line enable time, SEL to A, B, An, or Bn	$R_L = 50\ \Omega$ , $C_L = 5\ \text{pF}$ , See <a href="#">Figure 4</a>			30	ns
t <sub>OFF</sub>	Line disable time, SEL to A, B, An, or Bn	$R_L = 50\ \Omega$ , $C_L = 5\ \text{pF}$ , See <a href="#">Figure 4</a>			25	ns
t <sub>ON</sub>	Line enable time, $\overline{\text{OE}}$ to A, B, An, or Bn	$R_L = 50\ \Omega$ , $C_L = 5\ \text{pF}$ , See <a href="#">Figure 4</a>			30	ns
t <sub>OFF</sub>	Line disable time, $\overline{\text{OE}}$ to A, B, An, or Bn	$R_L = 50\ \Omega$ , $C_L = 5\ \text{pF}$ , See <a href="#">Figure 4</a>			25	ns
t <sub>SK(O)</sub>	Output skew between center port to any other port <sup>(2)</sup>	$R_L = 50\ \Omega$ , $C_L = 5\ \text{pF}$ , See <a href="#">Figure 9</a>			50	ps
t <sub>SK(P)</sub>	Skew between opposite transitions of the same output (t <sub>PHL</sub> - t <sub>PLH</sub> ) <sup>(2)</sup>	$R_L = 50\ \Omega$ , $C_L = 5\ \text{pF}$ , See <a href="#">Figure 9</a>			20	ps

 (1) For Max or Min conditions, use the appropriate value specified under [Electrical Characteristics](#) for the applicable device type.

(2) Specified by design

(3) The bus switch contributes no propagational delay other than the RC delay of the on resistance of the switch and the load capacitance. The time constant for the switch alone is of the order of 0.25 ns for 10-pF load. Since this time constant is much smaller than the rise/fall times of typical driving signals, it adds very little propagational delay to the system. Propagational delay of the bus switch, when used in a system, is determined by the driving circuit on the driving side of the switch and its interactions with the load on the driven side.

## 6.8 Typical Characteristics

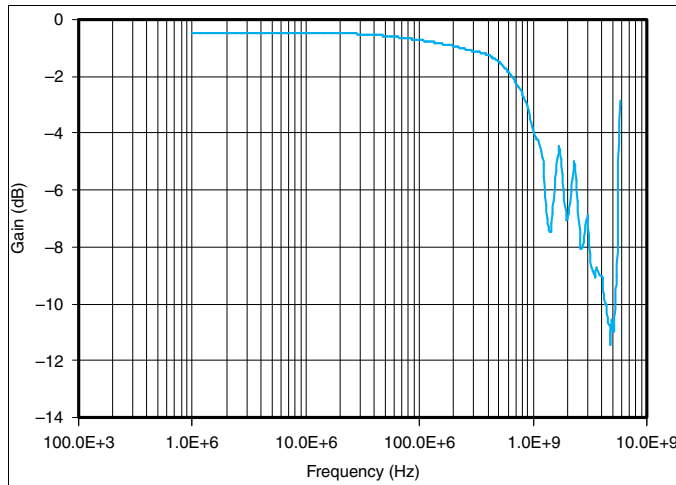

Figure 1. Bandwidth

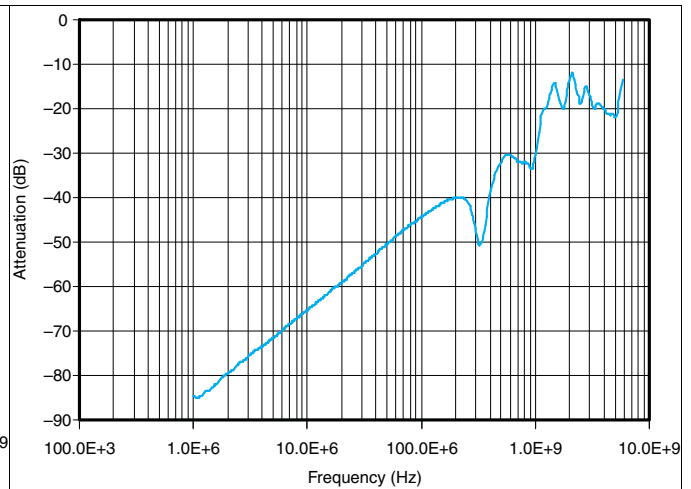

Figure 2. OFF Isolation

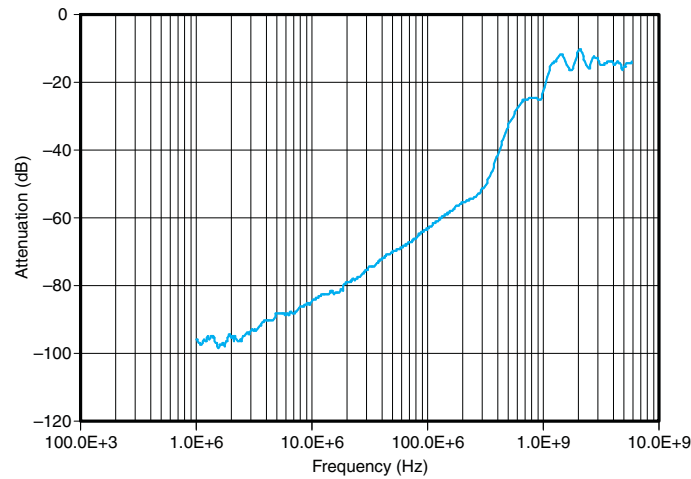
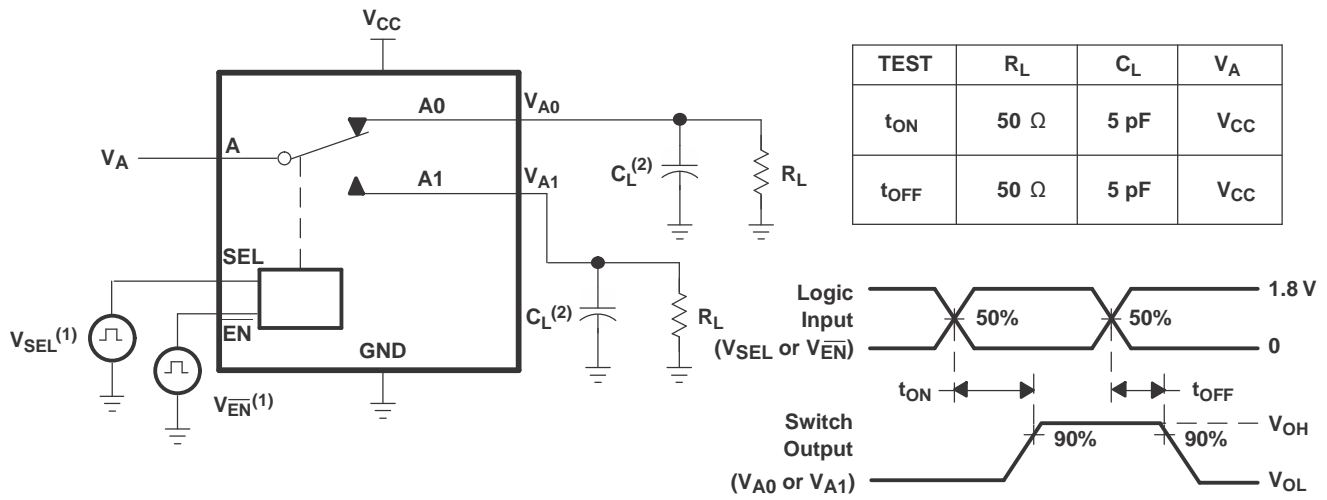

Figure 3. Crosstalk

## 7 Parameter Measurement Information



Copyright © 2018, Texas Instruments Incorporated

- (1) All input pulses are supplied by generators having the following characteristics: PRR ≤ 10 MHz, Z<sub>O</sub> = 50 Ω, t<sub>r</sub> < 5 ns, t<sub>f</sub> < 5 ns.
- (2) C<sub>L</sub> includes probe and jig capacitance.

Figure 4. Turn-On (t<sub>ON</sub>) and Turn-Off Time (t<sub>OFF</sub>)

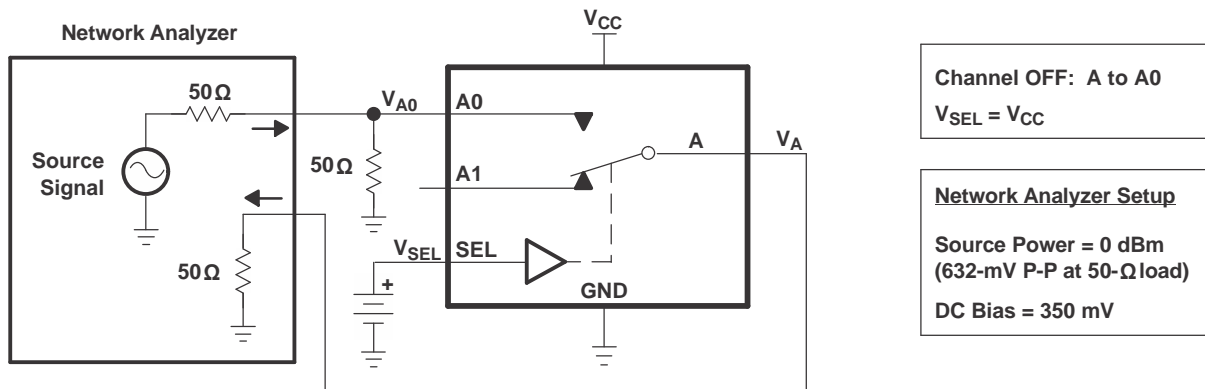

Copyright © 2018, Texas Instruments Incorporated

Figure 5. OFF Isolation (O<sub>ISO</sub>)

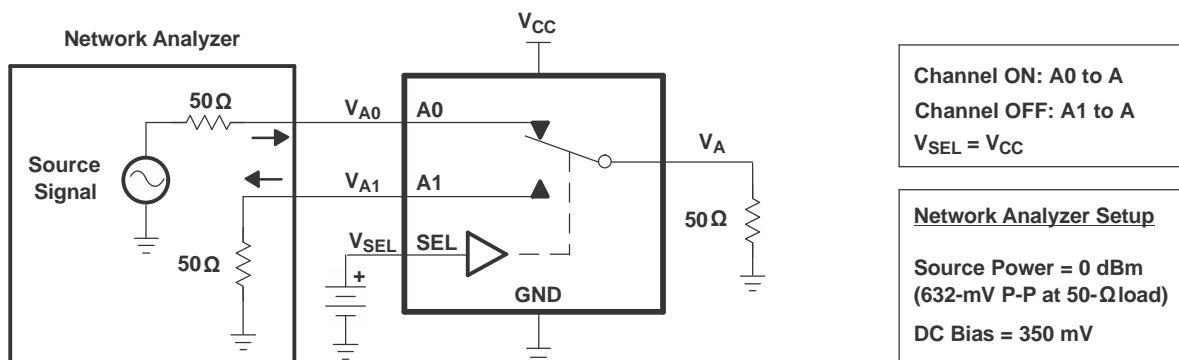

Copyright © 2018, Texas Instruments Incorporated

Figure 6. Crosstalk (X<sub>TALK</sub>)



**Parameter Measurement Information (continued)**

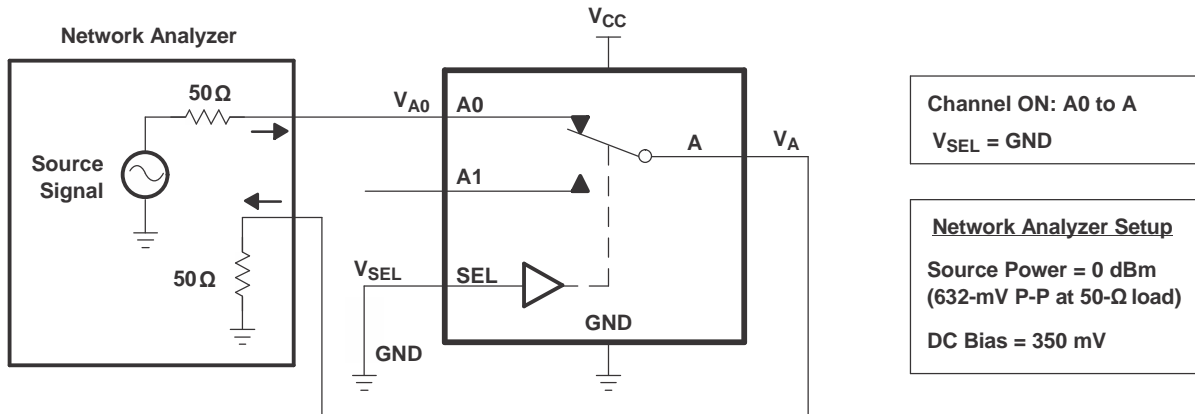

Copyright © 2018, Texas Instruments Incorporated

**Figure 7. Bandwidth (BW)**

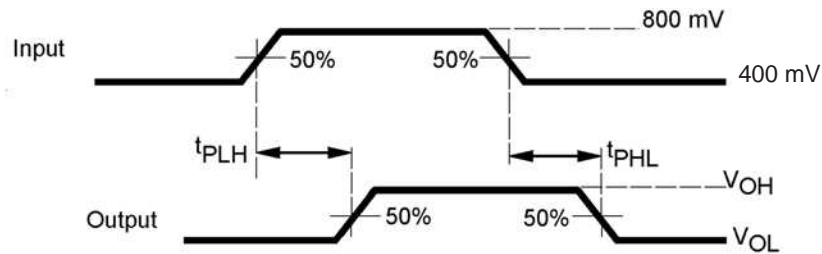

**Figure 8. Propagation Delay**

**Parameter Measurement Information (continued)**

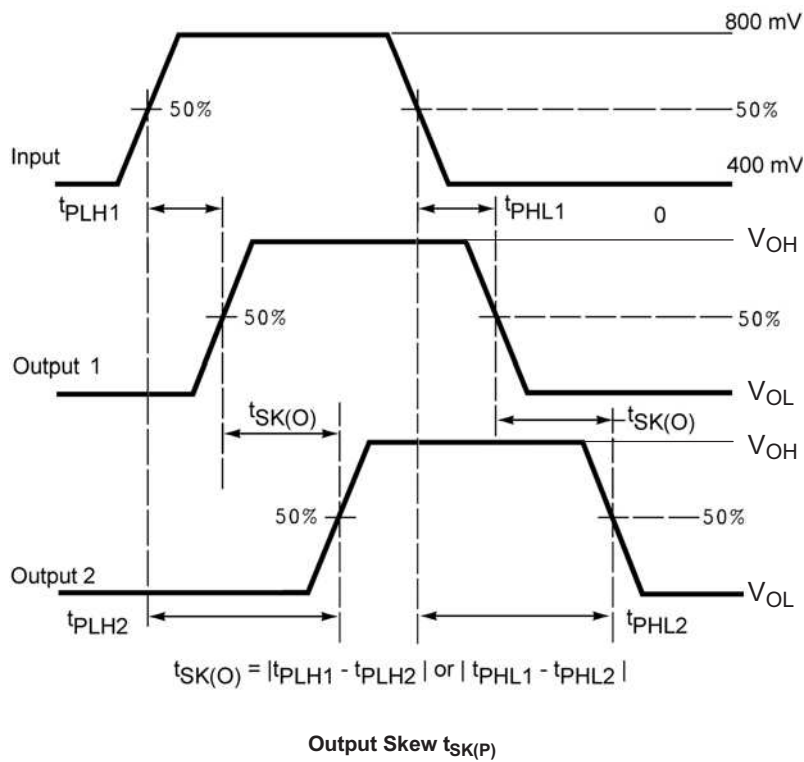
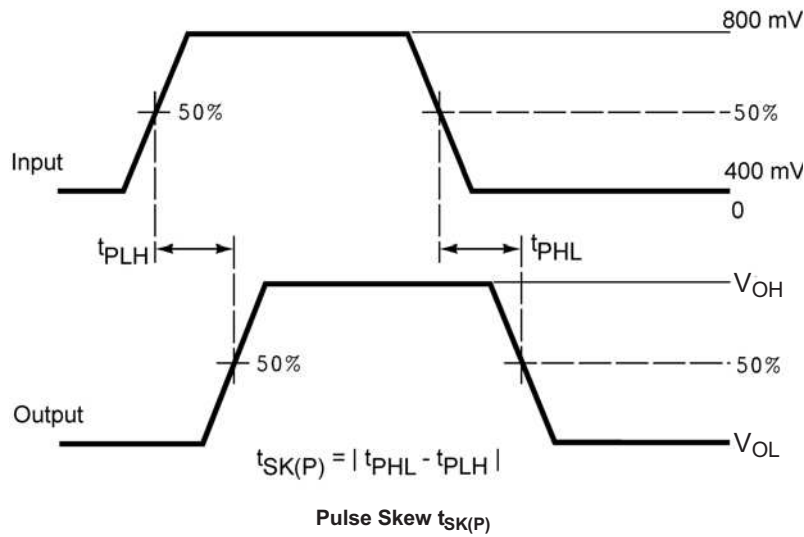

**Figure 9. Skew Test**

Parameter Measurement Information (continued)

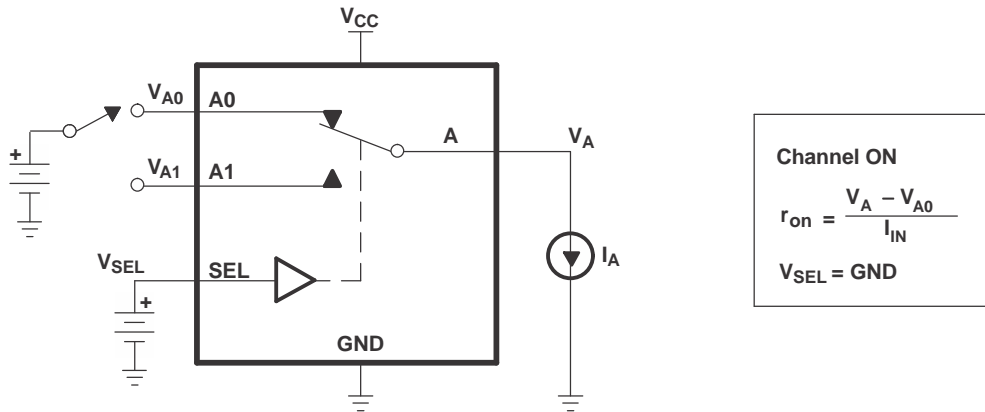

Copyright © 2018, Texas Instruments Incorporated

Figure 10. ON-State Resistance ( $R_{ON}$ )

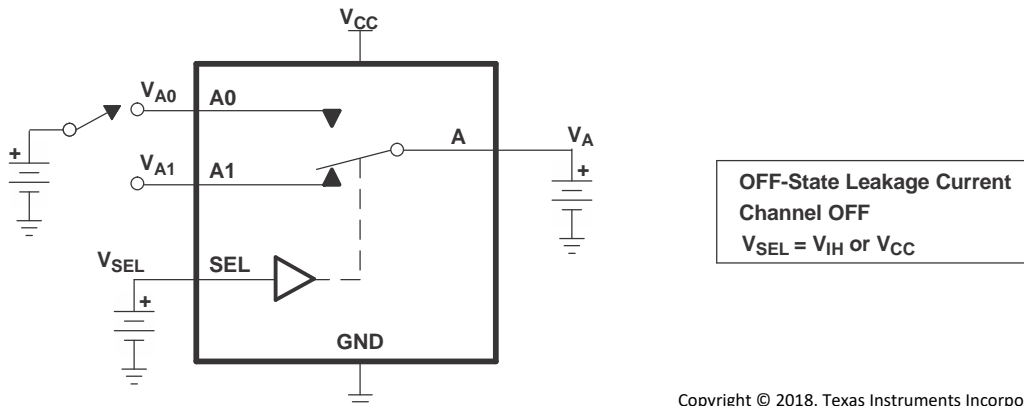

Copyright © 2018, Texas Instruments Incorporated

Figure 11. OFF-State Leakage Current

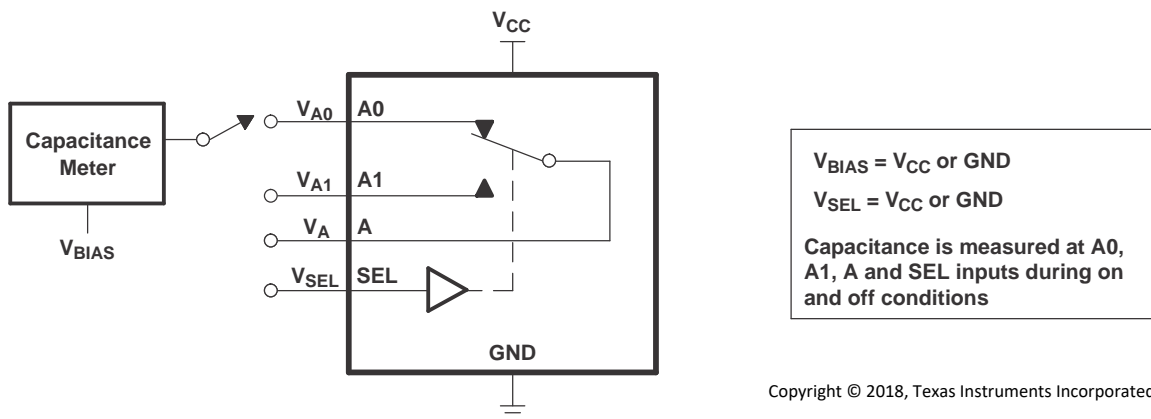

Copyright © 2018, Texas Instruments Incorporated

Figure 12. Capacitance

## 8 Detailed Description

### 8.1 Overview

The TMUX154E is a high-bandwidth switch specially designed for the switching and isolating of high-speed signals in systems with limited I/Os. The wide bandwidth (900 MHz) of this switch allows signals to pass with minimum edge and phase distortion. The device multiplexes differential or single ended signals from a single device to one of two corresponding outputs or from two different different devices to one single output. The switch is bidirectional and offers little or no attenuation of the high-speed signals. It is designed for low bit-to-bit skew and high channel-to-channel noise isolation.

### 8.2 Functional Block Diagram

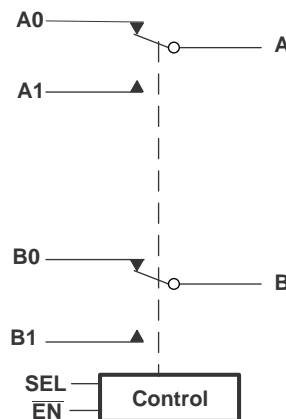

Copyright © 2018, Texas Instruments Incorporated

### 8.3 Feature Description

The TMUX154E has an enable pin  $\overline{\text{EN}}$  that can place the signal paths in high impedance. This allows the user to isolate the signal path when it is not in use and consume less current.

### 8.4 Device Functional Modes

The device functional modes are shown in [Table 1](#).

**Table 1. Truth Table**

SEL	$\overline{\text{EN}}$	FUNCTION
X	H	Disconnect
L	L	A = A0 B = B0
H	L	A = A1 B = B1

## 9 Application and Implementation

### NOTE

Information in the following applications sections is not part of the TI component specification, and TI does not warrant its accuracy or completeness. TI's customers are responsible for determining suitability of components for their purposes. Customers should validate and test their design implementation to confirm system functionality.

### 9.1 Application Information

There are many applications in which processors and microcontrollers have a limited number of I/Os. The TMUX154E solution can effectively expand the limited number of I/Os by switching between multiple signal paths in order to interface them to a single processor or microcontroller. TMUX154E can also be used to connect a single microcontroller to two signal paths.

### 9.2 Typical Application

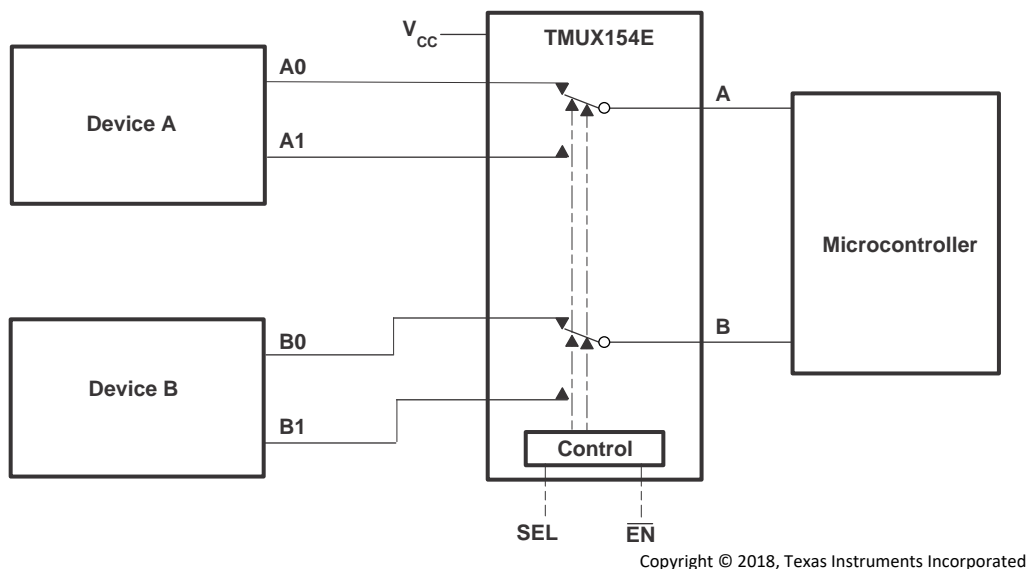

Figure 13. Application Diagram

#### 9.2.1 Design Requirements

TI recommends that the digital control pins SEL and  $\overline{\text{EN}}$  be pulled up to V<sub>CC</sub> or down to GND to avoid undesired switch positions that could result from the floating pin.

#### 9.2.2 Detailed Design Procedure

The TMUX154E can be properly operated without any external components. However, it is recommended that unused pins be connected to ground through a 50-Ω resistor to prevent signal reflections back into the device.

**Typical Application (continued)**

**9.2.3 Application Curves**

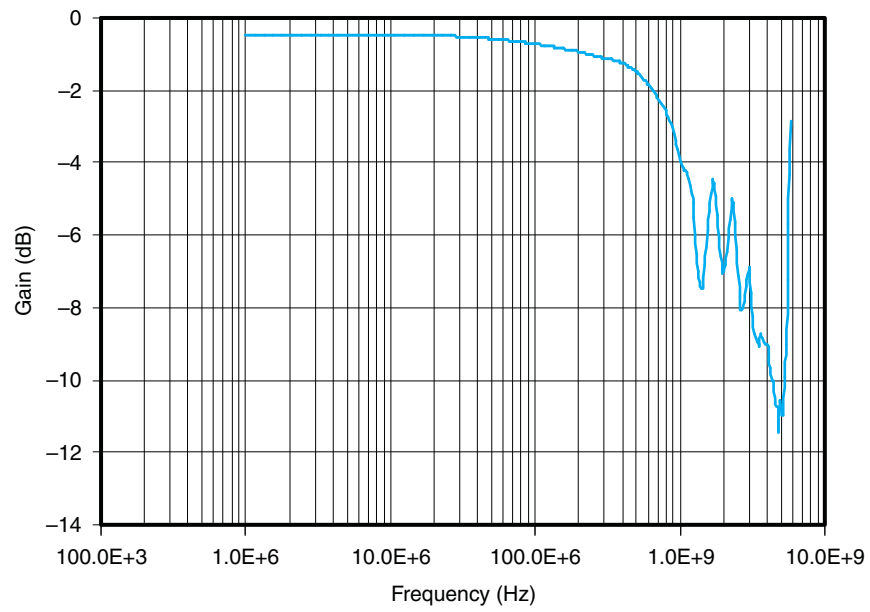

**Figure 14. Bandwidth**

## 10 Power Supply Recommendations

TI recommends placing a bypass capacitor as close as possible to the supply pin  $V_{CC}$  to help smooth out lower frequency noise to provide better load regulation across the frequency spectrum.

## 11 Layout

### 11.1 Layout Guidelines

Place supply bypass capacitors as close to  $V_{CC}$  pin as possible and avoid placing the bypass caps near the signal traces.

The high-speed traces should always be of equal length and must be no more than 4 inches; otherwise, the eye diagram performance may be degraded.

Route the high-speed signals using a minimum of vias and corners which will reduce signal reflections and impedance changes. When a via must be used, increase the clearance size around it to minimize its capacitance. Each via introduces discontinuities in the transmission line of the signal and increases the chance of picking up interference from the other layers of the board. Be careful when designing test points on twisted pair lines; through-hole pins are not recommended.

When it becomes necessary to turn 90°, use two 45° turns or an arc instead of making a single 90° turn. This reduces reflections on the signal traces by minimizing impedance discontinuities.

Do not route signal traces under or near crystals, oscillators, clock signal generators, switching regulators, mounting holes, magnetic devices, or IC's that use or duplicate clock signals.

Avoid stubs on the high-speed signals because they cause signal reflections.

Route all high-speed signal traces over continuous planes ( $V_{CC}$  or  $GND$ ), with no interruptions.

Avoid crossing over anti-etch, commonly found with plane splits.

For high frequency systems, a printed circuit board with at least four layers is recommended: two signal layers separated by a ground layer and a power layer. The majority of signal traces should run on a single layer, preferably Signal 1. Immediately next to this layer should be the  $GND$  plane, which is solid with no cuts. Avoid running signal traces across a split in the ground or power plane. When running across split planes is unavoidable, sufficient decoupling must be used. Minimizing the number of signal vias reduces EMI by reducing inductance at high frequencies. For more information on layout guidelines, see *High Speed Layout Guidelines (SCAA082)*

### 11.2 Layout Example

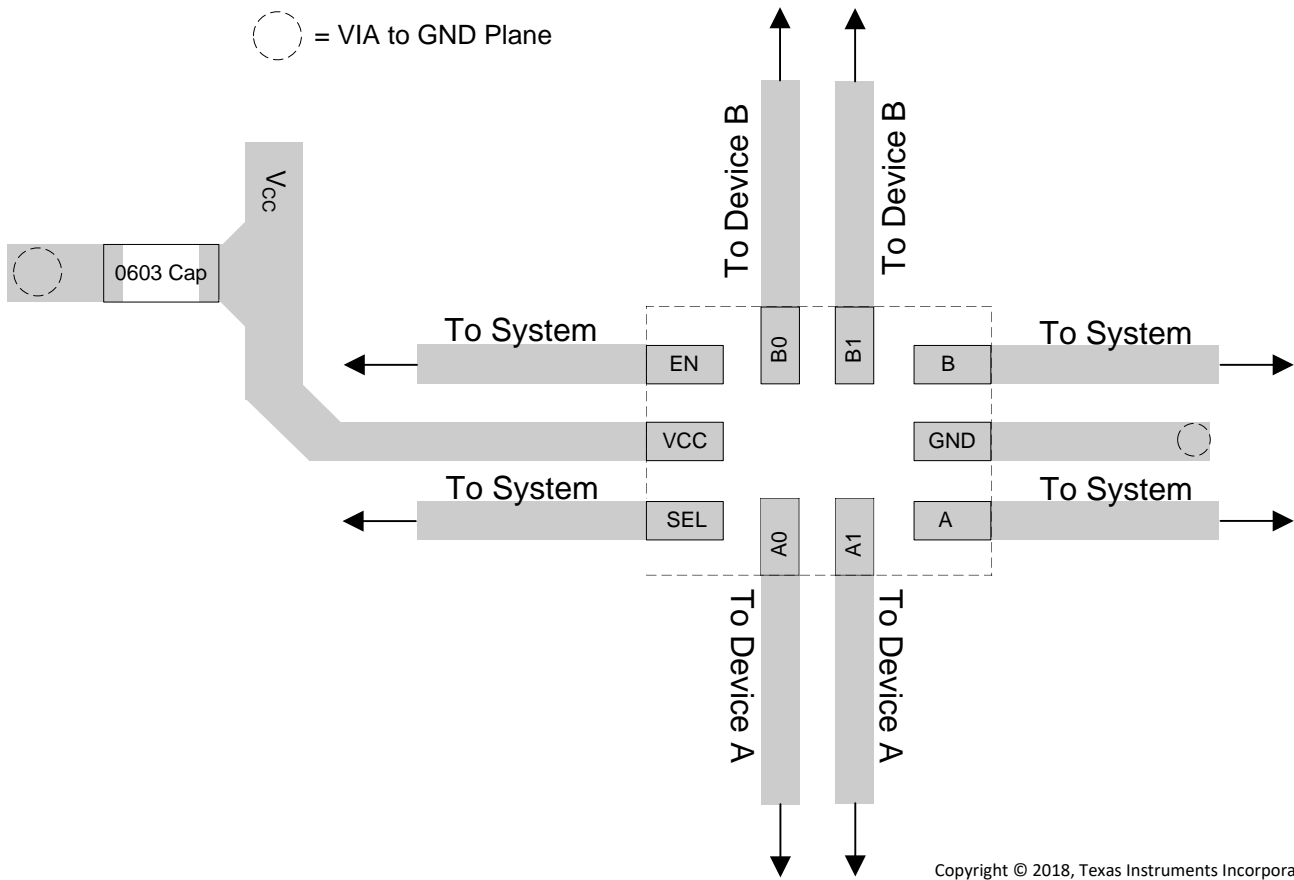

Figure 15. Layout Recommendation



## 12 Device and Documentation Support

### 12.1 Documentation Support

#### 12.1.1 Related Documentation

For related documentation, see the following:

- *Implications of Slow or Floating CMOS Inputs*, [SCBA004](#)
- *High Speed Layout Guidelines*, [SCAA082](#)

### 12.2 Receiving Notification of Documentation Updates

To receive notification of documentation updates, navigate to the device product folder on ti.com. In the upper right corner, click on *Alert me* to register and receive a weekly digest of any product information that has changed. For change details, review the revision history included in any revised document.

### 12.3 Community Resources

The following links connect to TI community resources. Linked contents are provided "AS IS" by the respective contributors. They do not constitute TI specifications and do not necessarily reflect TI's views; see TI's [Terms of Use](#).

**TI E2E™ Online Community** *TI's Engineer-to-Engineer (E2E) Community*. Created to foster collaboration among engineers. At e2e.ti.com, you can ask questions, share knowledge, explore ideas and help solve problems with fellow engineers.

**Design Support** *TI's Design Support* Quickly find helpful E2E forums along with design support tools and contact information for technical support.

### 12.4 Trademarks

E2E is a trademark of Texas Instruments.

All other trademarks are the property of their respective owners.

### 12.5 Electrostatic Discharge Caution



This integrated circuit can be damaged by ESD. Texas Instruments recommends that all integrated circuits be handled with appropriate precautions. Failure to observe proper handling and installation procedures can cause damage.

ESD damage can range from subtle performance degradation to complete device failure. Precision integrated circuits may be more susceptible to damage because very small parametric changes could cause the device not to meet its published specifications.

### 12.6 Glossary

**SLYZ022** — *TI Glossary*.

This glossary lists and explains terms, acronyms, and definitions.

### 13 Mechanical, Packaging, and Orderable Information

The following pages include mechanical, packaging, and orderable information. This information is the most current data available for the designated devices. This data is subject to change without notice and revision of this document. For browser-based versions of this data sheet, refer to the left-hand navigation.

**PACKAGING INFORMATION**

Orderable Device	Status (1)	Package Type	Package Drawing	Pins	Package Qty	Eco Plan (2)	Lead/Ball Finish (6)	MSL Peak Temp (3)	Op Temp (°C)	Device Marking (4/5)	Samples
TMUX154EDGSR	ACTIVE	VSSOP	DGS	10	2500	Green (RoHS & no Sb/Br)	CU NIPDAUAG	Level-1-260C-UNLIM	-40 to 85	1A6	<a href="#">Samples</a>
TMUX154ERSWR	ACTIVE	UQFN	RSW	10	3000	Green (RoHS & no Sb/Br)	CU NIPDAU	Level-1-260C-UNLIM	-40 to 85	BXV	<a href="#">Samples</a>

(1) The marketing status values are defined as follows:

**ACTIVE:** Product device recommended for new designs.

**LIFEBUY:** TI has announced that the device will be discontinued, and a lifetime-buy period is in effect.

**NRND:** Not recommended for new designs. Device is in production to support existing customers, but TI does not recommend using this part in a new design.

**PREVIEW:** Device has been announced but is not in production. Samples may or may not be available.

**OBsolete:** TI has discontinued the production of the device.

(2) **RoHS:** TI defines "RoHS" to mean semiconductor products that are compliant with the current EU RoHS requirements for all 10 RoHS substances, including the requirement that RoHS substance do not exceed 0.1% by weight in homogeneous materials. Where designed to be soldered at high temperatures, "RoHS" products are suitable for use in specified lead-free processes. TI may reference these types of products as "Pb-Free".

**RoHS Exempt:** TI defines "RoHS Exempt" to mean products that contain lead but are compliant with EU RoHS pursuant to a specific EU RoHS exemption.

**Green:** TI defines "Green" to mean the content of Chlorine (Cl) and Bromine (Br) based flame retardants meet JS709B low halogen requirements of <=1000ppm threshold. Antimony trioxide based flame retardants must also meet the <=1000ppm threshold requirement.

(3) MSL, Peak Temp. - The Moisture Sensitivity Level rating according to the JEDEC industry standard classifications, and peak solder temperature.

(4) There may be additional marking, which relates to the logo, the lot trace code information, or the environmental category on the device.

(5) Multiple Device Markings will be inside parentheses. Only one Device Marking contained in parentheses and separated by a "~" will appear on a device. If a line is indented then it is a continuation of the previous line and the two combined represent the entire Device Marking for that device.

(6) Lead/Ball Finish - Orderable Devices may have multiple material finish options. Finish options are separated by a vertical ruled line. Lead/Ball Finish values may wrap to two lines if the finish value exceeds the maximum column width.

**Important Information and Disclaimer:**The information provided on this page represents TI's knowledge and belief as of the date that it is provided. TI bases its knowledge and belief on information provided by third parties, and makes no representation or warranty as to the accuracy of such information. Efforts are underway to better integrate information from third parties. TI has taken and continues to take reasonable steps to provide representative and accurate information but may not have conducted destructive testing or chemical analysis on incoming materials and chemicals. TI and TI suppliers consider certain information to be proprietary, and thus CAS numbers and other limited information may not be available for release.

In no event shall TI's liability arising out of such information exceed the total purchase price of the TI part(s) at issue in this document sold by TI to Customer on an annual basis.



## TAPE AND REEL INFORMATION



### QUADRANT ASSIGNMENTS FOR PIN 1 ORIENTATION IN TAPE



\*All dimensions are nominal

Device	Package Type	Package Drawing	Pins	SPQ	Reel Diameter (mm)	Reel Width W1 (mm)	A0 (mm)	B0 (mm)	K0 (mm)	P1 (mm)	W (mm)	Pin1 Quadrant
TMUX154EDGSR	VSSOP	DGS	10	2500	330.0	12.4	5.3	3.4	1.4	8.0	12.0	Q1
TMUX154ERSWR	UQFN	RSW	10	3000	180.0	9.5	1.6	2.0	0.8	4.0	8.0	Q1

**TAPE AND REEL BOX DIMENSIONS**

\*All dimensions are nominal

Device	Package Type	Package Drawing	Pins	SPQ	Length (mm)	Width (mm)	Height (mm)
TMUX154EDGSR	VSSOP	DGS	10	2500	364.0	364.0	27.0
TMUX154ERSWR	UQFN	RSW	10	3000	189.0	185.0	36.0

DGS (S-PDSO-G10)

PLASTIC SMALL-OUTLINE PACKAGE



- NOTES:
- A. All linear dimensions are in millimeters.
  - B. This drawing is subject to change without notice.
  - C. Body dimensions do not include mold flash or protrusion.
  - D. Falls within JEDEC MO-187 variation BA.

DGS (S-PDSO-G10)

PLASTIC SMALL OUTLINE PACKAGE

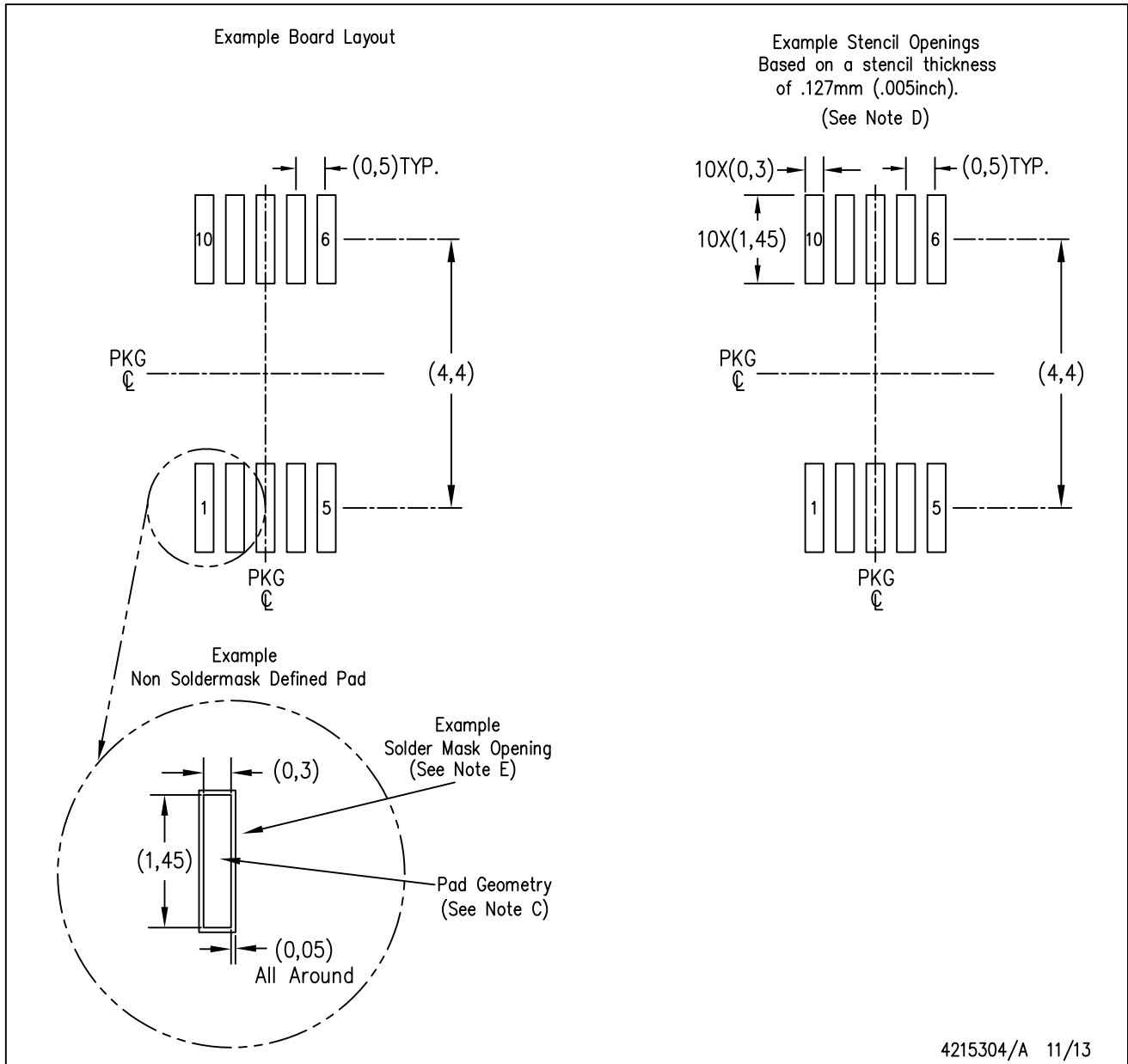

- NOTES:
- A. All linear dimensions are in millimeters.
  - B. This drawing is subject to change without notice.
  - C. Publication IPC-7351 is recommended for alternate designs.
  - D. Laser cutting apertures with trapezoidal walls and also rounding corners will offer better paste release. Customers should contact their board assembly site for stencil design recommendations. Refer to IPC-7525 for other stencil recommendations.
  - E. Customers should contact their board fabrication site for solder mask tolerances between and around signal pads.



**MECHANICAL DATA**

RSW (R-PUQFN-N10)

PLASTIC QUAD FLATPACK NO-LEAD

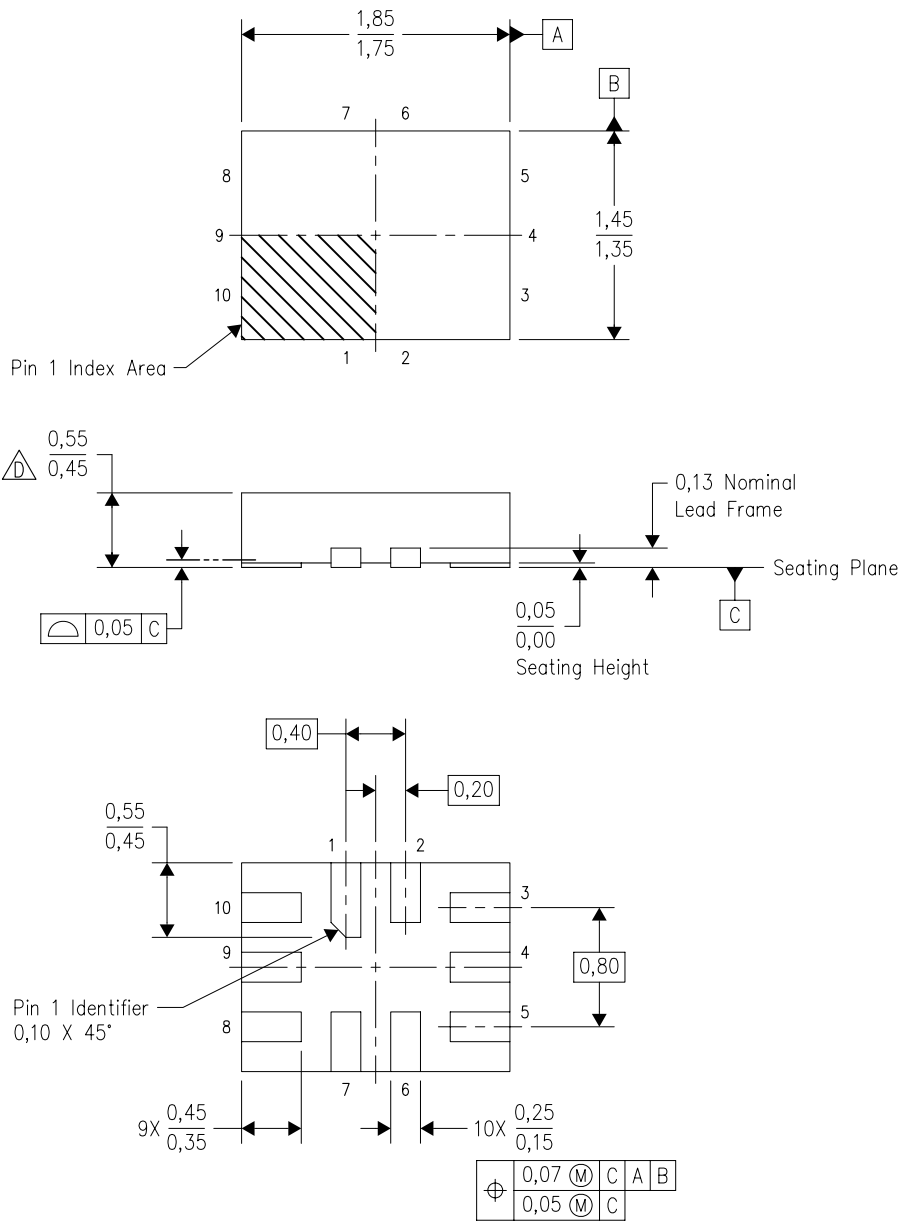

Bottom View

4208097/C 07/2008

- NOTES:
- A. All linear dimensions are in millimeters. Dimensioning and tolerancing per ASME Y14.5M-1994.
  - B. This drawing is subject to change without notice.
  - C. QFN (Quad Flatpack No-lead) package configuration.
  - This package complies to JEDEC MO-288 variation UDEE, except minimum package height.

## IMPORTANT NOTICE

Texas Instruments Incorporated (TI) reserves the right to make corrections, enhancements, improvements and other changes to its semiconductor products and services per JESD46, latest issue, and to discontinue any product or service per JESD48, latest issue. Buyers should obtain the latest relevant information before placing orders and should verify that such information is current and complete.

TI's published terms of sale for semiconductor products (<http://www.ti.com/sc/docs/stdterms.htm>) apply to the sale of packaged integrated circuit products that TI has qualified and released to market. Additional terms may apply to the use or sale of other types of TI products and services.

Reproduction of significant portions of TI information in TI data sheets is permissible only if reproduction is without alteration and is accompanied by all associated warranties, conditions, limitations, and notices. TI is not responsible or liable for such reproduced documentation. Information of third parties may be subject to additional restrictions. Resale of TI products or services with statements different from or beyond the parameters stated by TI for that product or service voids all express and any implied warranties for the associated TI product or service and is an unfair and deceptive business practice. TI is not responsible or liable for any such statements.

Buyers and others who are developing systems that incorporate TI products (collectively, "Designers") understand and agree that Designers remain responsible for using their independent analysis, evaluation and judgment in designing their applications and that Designers have full and exclusive responsibility to assure the safety of Designers' applications and compliance of their applications (and of all TI products used in or for Designers' applications) with all applicable regulations, laws and other applicable requirements. Designer represents that, with respect to their applications, Designer has all the necessary expertise to create and implement safeguards that (1) anticipate dangerous consequences of failures, (2) monitor failures and their consequences, and (3) lessen the likelihood of failures that might cause harm and take appropriate actions. Designer agrees that prior to using or distributing any applications that include TI products, Designer will thoroughly test such applications and the functionality of such TI products as used in such applications.

TI's provision of technical, application or other design advice, quality characterization, reliability data or other services or information, including, but not limited to, reference designs and materials relating to evaluation modules, (collectively, "TI Resources") are intended to assist designers who are developing applications that incorporate TI products; by downloading, accessing or using TI Resources in any way, Designer (individually or, if Designer is acting on behalf of a company, Designer's company) agrees to use any particular TI Resource solely for this purpose and subject to the terms of this Notice.

TI's provision of TI Resources does not expand or otherwise alter TI's applicable published warranties or warranty disclaimers for TI products, and no additional obligations or liabilities arise from TI providing such TI Resources. TI reserves the right to make corrections, enhancements, improvements and other changes to its TI Resources. TI has not conducted any testing other than that specifically described in the published documentation for a particular TI Resource.

Designer is authorized to use, copy and modify any individual TI Resource only in connection with the development of applications that include the TI product(s) identified in such TI Resource. NO OTHER LICENSE, EXPRESS OR IMPLIED, BY ESTOPPEL OR OTHERWISE TO ANY OTHER TI INTELLECTUAL PROPERTY RIGHT, AND NO LICENSE TO ANY TECHNOLOGY OR INTELLECTUAL PROPERTY RIGHT OF TI OR ANY THIRD PARTY IS GRANTED HEREIN, including but not limited to any patent right, copyright, mask work right, or other intellectual property right relating to any combination, machine, or process in which TI products or services are used. Information regarding or referencing third-party products or services does not constitute a license to use such products or services, or a warranty or endorsement thereof. Use of TI Resources may require a license from a third party under the patents or other intellectual property of the third party, or a license from TI under the patents or other intellectual property of TI.

TI RESOURCES ARE PROVIDED "AS IS" AND WITH ALL FAULTS. TI DISCLAIMS ALL OTHER WARRANTIES OR REPRESENTATIONS, EXPRESS OR IMPLIED, REGARDING RESOURCES OR USE THEREOF, INCLUDING BUT NOT LIMITED TO ACCURACY OR COMPLETENESS, TITLE, ANY EPIDEMIC FAILURE WARRANTY AND ANY IMPLIED WARRANTIES OF MERCHANTABILITY, FITNESS FOR A PARTICULAR PURPOSE, AND NON-INFRINGEMENT OF ANY THIRD PARTY INTELLECTUAL PROPERTY RIGHTS. TI SHALL NOT BE LIABLE FOR AND SHALL NOT DEFEND OR INDEMNIFY DESIGNER AGAINST ANY CLAIM, INCLUDING BUT NOT LIMITED TO ANY INFRINGEMENT CLAIM THAT RELATES TO OR IS BASED ON ANY COMBINATION OF PRODUCTS EVEN IF DESCRIBED IN TI RESOURCES OR OTHERWISE. IN NO EVENT SHALL TI BE LIABLE FOR ANY ACTUAL, DIRECT, SPECIAL, COLLATERAL, INDIRECT, PUNITIVE, INCIDENTAL, CONSEQUENTIAL OR EXEMPLARY DAMAGES IN CONNECTION WITH OR ARISING OUT OF TI RESOURCES OR USE THEREOF, AND REGARDLESS OF WHETHER TI HAS BEEN ADVISED OF THE POSSIBILITY OF SUCH DAMAGES.

Unless TI has explicitly designated an individual product as meeting the requirements of a particular industry standard (e.g., ISO/TS 16949 and ISO 26262), TI is not responsible for any failure to meet such industry standard requirements.

Where TI specifically promotes products as facilitating functional safety or as compliant with industry functional safety standards, such products are intended to help enable customers to design and create their own applications that meet applicable functional safety standards and requirements. Using products in an application does not by itself establish any safety features in the application. Designers must ensure compliance with safety-related requirements and standards applicable to their applications. Designer may not use any TI products in life-critical medical equipment unless authorized officers of the parties have executed a special contract specifically governing such use. Life-critical medical equipment is medical equipment where failure of such equipment would cause serious bodily injury or death (e.g., life support, pacemakers, defibrillators, heart pumps, neurostimulators, and implantables). Such equipment includes, without limitation, all medical devices identified by the U.S. Food and Drug Administration as Class III devices and equivalent classifications outside the U.S.

TI may expressly designate certain products as completing a particular qualification (e.g., Q100, Military Grade, or Enhanced Product). Designers agree that it has the necessary expertise to select the product with the appropriate qualification designation for their applications and that proper product selection is at Designers' own risk. Designers are solely responsible for compliance with all legal and regulatory requirements in connection with such selection.

Designer will fully indemnify TI and its representatives against any damages, costs, losses, and/or liabilities arising out of Designer's non-compliance with the terms and provisions of this Notice.